



INTERNATIONAL APPLICATION PUBLISHED UNDER THE PATENT COOPERATION TREATY (PCT)

<p>(51) International Patent Classification ⁶ : E05G 7/00</p>	<p>A1</p>	<p>(11) International Publication Number: WO 97/47843 (43) International Publication Date: 18 December 1997 (18.12.97)</p>
<p>(21) International Application Number: PCT/NL97/00331 (22) International Filing Date: 11 June 1997 (11.06.97) (30) Priority Data: 1003324 12 June 1996 (12.06.96) NL (71) Applicant (for all designated States except US): DZB-DE ZIJL BEDRIJVEN [NL/NL]; Touwbaan 40, NL-2352 CZ Leiderdorp (NL). (72) Inventors; and (75) Inventors/Applicants (for US only): VAN GEER, René, Jo- han [NL/NL]; Haagweg 163, NL-2281 AJ Rijswijk (NL). KOMMER, Adriaan [NL/NL]; Cameoolstraat 44, NL-2332 KC Leiden (NL). (74) Agent: DE BRUIJN, Leendert, C.; Nederlandsch Octrooibu- reau, Scheveningseweg 82, P.O. Box 29720, NL-2502 LS The Hague (NL).</p>		<p>(81) Designated States: AL, AM, AT, AU, AZ, BA, BB, BG, BR, BY, CA, CH, CN, CU, CZ, DE, DK, EE, ES, FI, GB, GE, GH, HU, IL, IS, JP, KE, KG, KP, KR, KZ, LC, LK, LR, LS, LT, LU, LV, MD, MG, MK, MN, MW, MX, NO, NZ, PL, PT, RO, RU, SD, SE, SG, SI, SK, TJ, TM, TR, TT, UA, UG, US, UZ, VN, YU, ARIPO patent (GH, KE, LS, MW, SD, SZ, UG), Eurasian patent (AM, AZ, BY, KG, KZ, MD, RU, TJ, TM), European patent (AT, BE, CH, DE, DK, ES, FI, FR, GB, GR, IE, IT, LU, MC, NL, PT, SE), OAPI patent (BF, BJ, CF, CG, CI, CM, GA, GN, ML, MR, NE, SN, TD, TG). Published With international search report.</p>

(54) Title: COUNTER DEVICE WITH SLIDING DOORS

(57) Abstract

Counter device for performing transactions between a first person at the one side of the stand and a second person at the other side of the stand, comprising: at least one transaction space (24, 26), through which goods can be transferred from the first person to the second person and vice versa; a first door (36) at the one side through which door the one person may have access to the transaction space; a second door (38) at the other side through which door the second person may have access to the transaction space; a first driving mechanism for driving the first door; a second driving mechanism for driving the second door; a control unit for controlling the first and second driving mechanism, such that both doors always move in opposite directions, and both doors always simultaneously will pass the central position in which the transaction spaces are both completely closed.

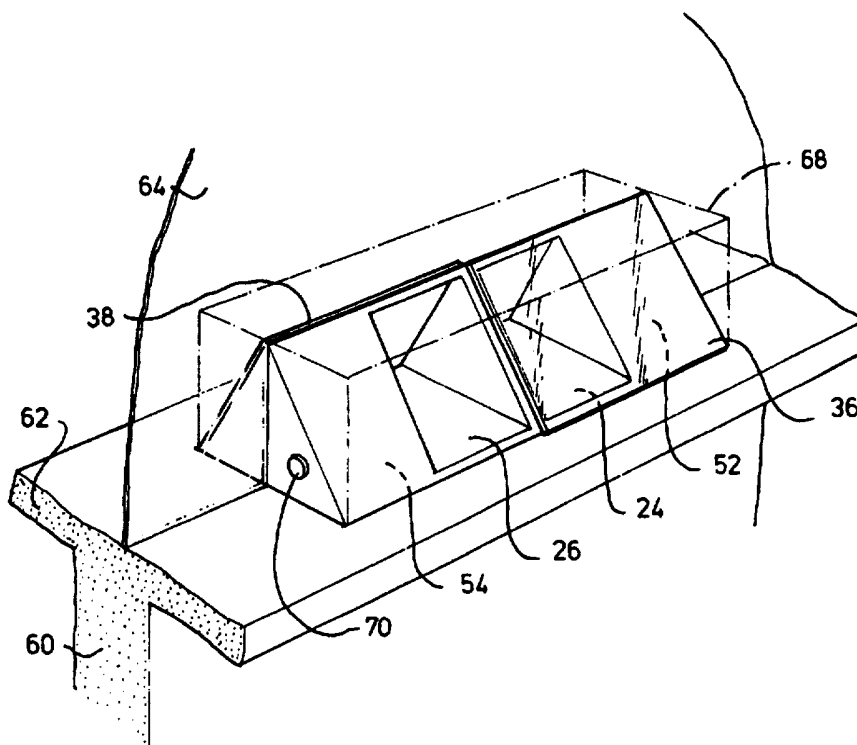

FOR THE PURPOSES OF INFORMATION ONLY

Codes used to identify States party to the PCT on the front pages of pamphlets publishing international applications under the PCT.

AL	Albania	ES	Spain	LS	Lesotho	SI	Slovenia
AM	Armenia	FI	Finland	LT	Lithuania	SK	Slovakia
AT	Austria	FR	France	LU	Luxembourg	SN	Senegal
AU	Australia	GA	Gabon	LV	Latvia	SZ	Swaziland
AZ	Azerbaijan	GB	United Kingdom	MC	Monaco	TD	Chad
BA	Bosnia and Herzegovina	GE	Georgia	MD	Republic of Moldova	TG	Togo
BB	Barbados	GH	Ghana	MG	Madagascar	TJ	Tajikistan
BE	Belgium	GN	Guinea	MK	The former Yugoslav	TM	Turkmenistan
BF	Burkina Faso	GR	Greece		Republic of Macedonia	TR	Turkey
BG	Bulgaria	HU	Hungary	ML	Mali	TT	Trinidad and Tobago
BJ	Benin	IE	Ireland	MN	Mongolia	UA	Ukraine
BR	Brazil	IL	Israel	MR	Mauritania	UG	Uganda
BY	Belarus	IS	Iceland	MW	Malawi	US	United States of America
CA	Canada	IT	Italy	MX	Mexico	UZ	Uzbekistan
CF	Central African Republic	JP	Japan	NE	Niger	VN	Viet Nam
CG	Congo	KE	Kenya	NL	Netherlands	YU	Yugoslavia
CH	Switzerland	KG	Kyrgyzstan	NO	Norway	ZW	Zimbabwe
CI	Côte d'Ivoire	KP	Democratic People's	NZ	New Zealand		
CM	Cameroon		Republic of Korea	PL	Poland		
CN	China	KR	Republic of Korea	PT	Portugal		
CU	Cuba	KZ	Kazakstan	RO	Romania		
CZ	Czech Republic	LC	Saint Lucia	RU	Russian Federation		
DE	Germany	LI	Liechtenstein	SD	Sudan		
DK	Denmark	LK	Sri Lanka	SE	Sweden		
EE	Estonia	LR	Liberia	SG	Singapore		

Counter device with sliding doors

The invention relates to a counter device.

As such are counter devices already known in various different
5 embodiments. In common use is for instance a counter device whereby
there is a separation between both persons involved in a transaction,
for instance embodied as a glass panel of sufficient height which at the
underside ends on a horizontal counter. The counter comprises a cavity
through which goods may be shifted from the one side to the other side.
10 A disadvantage of such a device is that there is in fact an open con-
nection between both sides of the counter device.

Known are furthermore devices in which this open connection as it
were is filled using a rotatable platform partitioned in compartments.
Each person can put its goods in a separate compartment of the rotatable
15 platform and by rotating thereafter the platform over 180° the goods are
transported underneath the separating wall to the other side of the
counter device. During the rotation of the platform it is not inconceiv-
able that light objects, as for instance paper money, will move from the
platform and therefore will not be correctly transported to the other
20 side. Furthermore, the dimensions of these rotating platforms are in
many cases selected in a restrictive manner such that large objects can-
not be transported through this rotating platform.

An object of the invention is now to provide a counter device
whereby there is no direct connection between both sides and whereby
25 also larger objects can be exchanged between the persons involved in a
transaction.

In agreement with said object the invention now provides a coun-
ter device for performing transactions between a first person at the one
side of the stand and a second person at the other side of the stand,
30 comprising:

- two adjacent and mutually separated transaction spaces, through which
goods can be transferred from the first person to the second person and
vice versa,
- a first sliding door at the one side which in the intermediate state
35 closes both transaction spaces,
- a second sliding door at the other side which in the intermediate
state closes both transaction spaces,
- a first driving mechanism for driving the first sliding door in a
first direction to a first extreme position in which the first trans-

action space is opened but the second transaction space is closed, or in a second opposed direction to a second extreme position in which the second transaction space is opened but the first transaction space is closed,

5 - a second driving mechanism for driving the second door in a first direction to a first extreme position in which the first transaction space is opened but the second transaction space is closed, or in a second opposed direction to a second extreme position in which the second transaction space is opened but the first transaction space is closed,

10 - a control unit for controlling both driving mechanisms such that both doors always will move in opposite direction and will be in the intermediate position simultaneously.

Because both doors always from the intermediate position, in which both transaction spaces are closed at both sides, are moving in opposite directions to the respective extreme positions there is always a situation in which the one transaction space is only accessible from the one side, whereas the other transaction space is only accessible from the other side or vice versa. Even if both doors from such a situation will start moving to the other extreme position then they will simultaneously pass the intermediate position. Therefore there is never a situation in which a transaction space is accessible from both sides.

20 A further simplification of the construction of the counter device can be obtained by partly or completely combining both driving mechanisms and embody these mechanisms such that both doors are moved simultaneously in opposite direction. Especially the control unit can be heavily simplified because said unit will then function only for starting and stopping the combined driving mechanism.

30 Within the scope of the invention the doors can be installed vertical at both sides of rectangular transaction spaces. However, in many cases this is not very practical. It is therefore preferred that the doors are sloping under an angle of about 45° with the horizontal plane such that the doors at both sides of the transaction spaces are positioned in planes which make a mutual angle of about 90°.

35 Therewith a number of advantages are obtained, such as a good visibility of the contents of the transaction spaces for both persons, better bulletproofness, simply rescaleable and still using lots of exactly the same components, many rectangular and therewith easy to

produce parts.

Although there could be reasons to use non-transparent material for the doors, it is in most cases preferable that the doors are made of a transparent material. In that case all manipulations carried out by
5 both persons are visible for both persons.

To increase security it is furthermore preferred that the doors are made of a bulletproof material, especially bulletproof glass or plastic.

To be able to install the motors for powering the driving mechanisms it is preferable that the device furthermore comprises at least
10 one component space adjacent to one of the transaction spaces, in which component space at least part of the drive mechanisms is installed.

The invention will be explained in more detail with reference to the attached drawings.

15 Figures 1a ... 1c illustrate for a first embodiment schematically in cross sectional view the transaction spaces and the corresponding sliding doors in various positions.

Figures 2a ... 2c illustrate for a second embodiment schematically in cross sectional view the transaction spaces and the corresponding sliding doors in various positions.
20

Figure 3 illustrates a perspective view of a preferred embodiment of the counter device according to the invention, whereby the doors are installed in a sloped situation.

A very simple embodiment of the counter device is schematically
25 illustrated in the figures 1a ... 1c. In this embodiment the apparatus comprises three standing walls 30, 32, and 34 and two sliding doors 36 and 38. The standing walls 30 and 32 define together with the non-visible upper and lower wall a first transaction space 26 and the walls 32 and 34 define, also together with the non-visible upper and lower
30 wall a second transaction space 24. Both doors 36 and 38 have such a width that in the neutral central position, illustrated in figure 1a, both transaction spaces 24 and 26 are completely closed.

Both doors 36 and 38 are manipulated by means of door operation mechanisms. These operation mechanisms are controlled such, that in case
35 one transaction space is accessible from the one side the accession from the other side is inhibited. By moving the slidable doors from the central position, which is illustrated in figure 1a, each time in opposite directions to the one or the other side, two situations can be obtained,

whereby each time the requirement, that one transaction space can be only accessible from one side, is fulfilled. In figure 1b the situation is illustrated in which the door 38 is slid to the left, whereas the door 36 is slid to the right. In the obtained situation the transaction space 24 is accessible from the one side but is closed at the other side by the door 36. The second transaction space 26 is accessible from the other side, but the one side is closed by the door 38.

If now both doors are slid in opposite direction until the other extreme positions are obtained, then the situation according to figure 1c is created in which the transaction space 24 is closed at one side by the door 38 whereas the transaction space 26 is closed at the other side by door 36. During the transition from the situation illustrated in figure 1b to the situation of figure 1c both doors simultaneously pass through the neutral central position as illustrated in figure 1a. In other words, there will never be a situation in which a transaction space is accessible from both sides, not even through a small chink.

It is possible to apply identical driving mechanisms for both doors and to control both driving mechanisms by a controller which takes care of fulfilling the requirements i.e.:

- both doors always move in opposite directions, and
- both doors always simultaneously will pass the central position in which the transaction spaces are both completely closed.

A suitable electronic controller is within reach of the expert in this field and does not require further explanation.

Apart from that it is also possible to combine both driving mechanisms partly or as a whole and to couple these mechanisms mechanically such that the moving possibilities of both doors are restricted such that only the allowed movements are possible. The controller can be reduced strongly in that case and in fact only operates for starting and stopping the combined driving mechanisms. This is also considered within reach of the expert and further explanation is considered superfluous.

Irrespective of the configuration of the controller the embodiment of figures 1a, b, c, has the advantage that with one push button the situation can be changed from the one illustrated in figure 1b to the one illustrated in figure 1c. In practice, performing a transaction with the device according to figure 1 is very simple. If the counter device is for instance applied at a railway station for selling railway tickets and the operation starts with the situation illustrated in

figure 1b, then the transaction space 24 is accessible for the traveller, whereas the railway employee has access to the transaction space 26. The traveller puts the required amount of money in the transaction space 24 and simultaneously the railway employee will put the railway ticket together with eventual change in the transaction space 26. After one push on the button both doors 36 and 38 will move to the other extreme position and will obtain the situation according to figure 1c, whereby the traveller is able to collect its ticket and its change from the space 26 whereas the railway employee is able to get the money out of the space 24.

During this whole procedure there is never a situation in which a transaction space is accessible from both sides. Furthermore, the operation of the doors is completely controlled by the railway employee which therewith alone is responsible for the functional performance of the transaction. The transaction space can be embodied relatively large so that eventually also packages of a certain volume can be exchanged.

A further embodiment of the device according to figure 1 is schematically illustrated in the figures 2a ... 2c. In this embodiment apart from the transaction spaces 24 and 26 there are two further spaces created, which in general are closed and indicated by 52 and 54. The space 52 is created in the illustrated manner by combining the side wall 30 with further walls 40, 42, and 44 to obtain the closed space 52. Furthermore, the other side wall 34 is combined with further side walls 46, 48, and 50 to obtain the closed space 54. It will be clear that also the spaces 52 and 54 are closed at the upper and lower side by an upper wall respectively a lower wall. It will furthermore be clear that these spaces can be made accessible through a door or by removing one of the walls for maintenance and repair purposes. Inside the spaces 52 and 54 the driving mechanisms are installed for moving the doors 38 and 36. These doors run for example along a rail at the upper and lower side, whereby toothed belts, snares or similar devices are used to move said doors. These toothed belts, snares, etc. are operated in a known manner by one or more electric motors, which could be installed inside the spaces 52, 54 and in turn these electric motors will be controlled by a suitable electronic circuit which, in cooperation with various sensors, takes care that the doors are able to move from the central position to one of the desired extreme positions always such, that both doors move in opposite direction and always such that both doors simultaneously

pass through the central position. The realization of the necessary electronics is considered within reach of the expert in this field and therefore the necessary electronic circuits making up the controller will not be explained in detail.

5 The dimensions of the walls 40, 46, 50, 54 are preferably selected such that in the completely opened situation the doors 36 and 38 do not extend further than the end walls 42, 48. The situation with opened doors in the one extreme position is illustrated in figure 2b and the situation with opened doors in the other extreme position is illustrated
10 in figure 2c.

 Figure 3 illustrates in a perspective view the application of a counter device as schematically illustrated in figure 2 in a more practical setting. The separation between the counter employee and the outside world is on the one hand formed by wall 60 carrying the counter 62,
15 the upper side of which connects to a glass separating panel 64. For all these components preferably strong materials with high breaking strength and if necessary bulletproofness are applied. In the glass panel 64 a rectangular elongated opening is made in which the counter device as illustrated in figure 2 is shifted in and fixed. This illustrates
20 directly one of the advantages of the embodiment of figure 2. The device as a whole can be prefabricated and preassembled and can be installed very easily by making a rectangular opening with predetermined dimensions in the respective panel, after which the counter device as a whole can be shifted inside said opening and can be mounted and fixed at the
25 desired position, for instance both to the glass panel 64 as well as to the counter blade 62.

 In the embodiment of figure 3 in any case preferably the doors 36 and 38 are made of a transparent material, so that both the counter employee at the one side as well as the client at the other side is able
30 to watch into the transaction spaces 24 and 26.

 As is already remarked above the device as a whole can have a rectangular shape as is indicated by the dot lines 68 in figure 3. Therewith the doors 36 and 38 are in a vertical position. To bring about as less restrictions as possible to the view inside the transaction
35 spaces in that case the upper wall of the device should be made of a transparent material.

 For various reasons, which will be mentioned hereinafter, it is preferred to give the device in longitudinal cross section a triangular

shape as is illustrated in figure 3 with the full lines. Therewith the doors are sloped under an angle of about 45° with relation to the horizontal surface. This brings about the following advantages:

- 5 - The counter employee and the customer both have a good view on the contents of the transaction spaces. If the doors are mounted to rails at the upper and lower side then in the rectangular shape these rails would impair the view. In the triangular shape these rails are positioned near the top of the triangle and do not impair the view.
- 10 - The bulletproofness of the device is better than in the situation with vertical doors. A bullet will always hit the doors under an angle and will ricochet or will stick in the material. Because the door is under an angle the bulletproofness thereof is comparable with a much thicker vertical panel. So, a relatively
15 thinner material can be used for the doors which leads to a decrease in weight of the device as a whole.
- The product can be rescaled to other dimensions very easily still making use of the same parts belonging to the driving mechanisms.
- All parts are rectangular and rather easy to produce.
- 20 - The device allows very easy fixation in a rectangular opening in the separating wall.

The component spaces 52 and 54 at both sides of the transaction spaces 24 and 26 contain, also in this embodiment, components of the driving mechanism and the control unit. The only externally visible
25 component is the push button 70 which can be mounted at one side as illustrated in the figure, but can be installed also elsewhere, for instance in the counter blade 62. This push button enables the counter employee to control the device.

Claims

1. Counter device for performing transactions between a first person at the one side of the stand and a second person at the other side of the stand, comprising:
- two adjacent and mutually separated transaction spaces, through which goods can be transferred from the first person to the second person and vice versa,
 - a first sliding door at the one side which in the intermediate state closes both transaction spaces,
 - a second sliding door at the other side which in the intermediate state closes both transaction spaces,
 - a first driving mechanism for driving the first sliding door in a first direction to a first extreme position in which the first transaction space is opened but the second transaction space is closed, or in a second opposed direction to a second extreme position in which the second transaction space is opened but the first transaction space is closed,
 - a second driving mechanism for driving the second door in a first direction to a first extreme position in which the first transaction space is opened but the second transaction space is closed, or in a second opposed direction to a second extreme position in which the second transaction space is opened but the first transaction space is closed,
 - a control unit for controlling both driving mechanisms such that both doors always will move in opposite direction and will be in the intermediate position simultaneously.

2. Counter device according to claim 1, characterized in that the driving mechanisms are partly or as a whole combined and embodied such that both doors are simultaneously moved in opposite directions.

3. Counter device according to one of the preceding claims, characterized in that the doors are sloping under an angle of about 45° with the horizontal plane such that the doors at both sides of the transaction spaces are positioned in planes which make a mutual angle of about 90°.

4. Counter device according to one of the preceding claims, characterized in that the doors are made of a transparent material.

5. Counter device according to one of the preceding claims, characterized in that the doors are made of bulletproof material.

6. Counter device according to one of the preceding claims, characterized in that the structure comprises furthermore at least one component space adjacent to one of the transaction spaces, in which component space at least part of the drive mechanisms is installed.

fig-1a

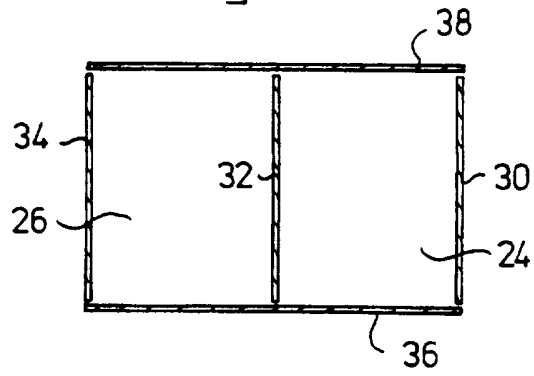

fig-1b

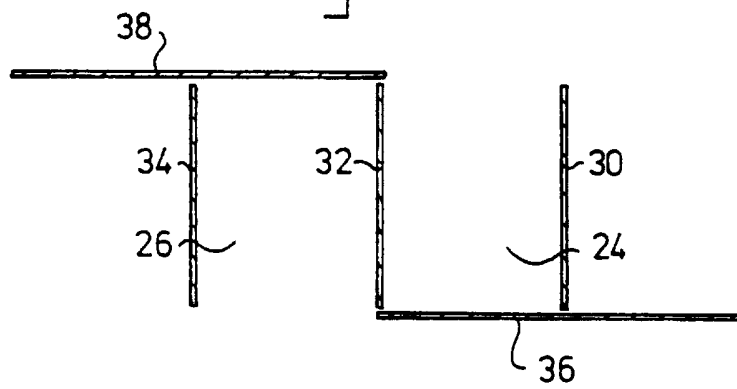

fig-1c

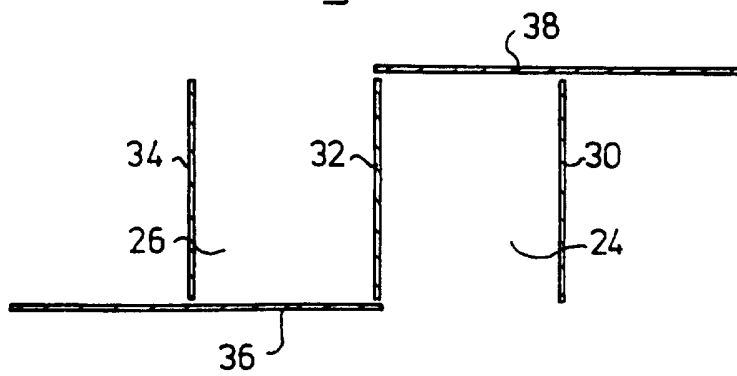

fig-2a

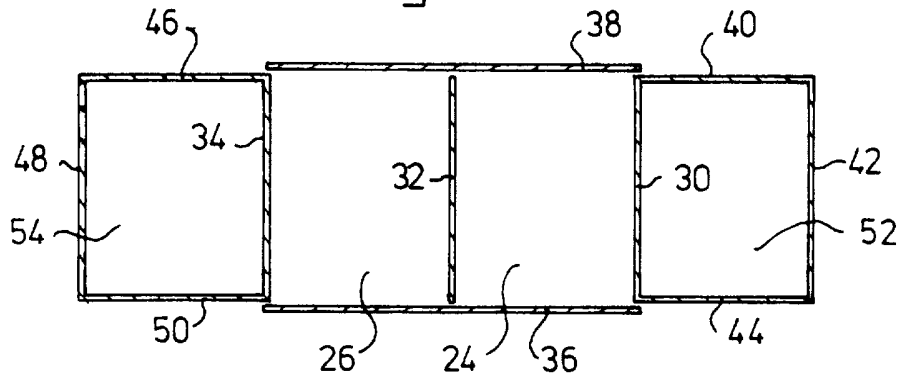

fig-2b

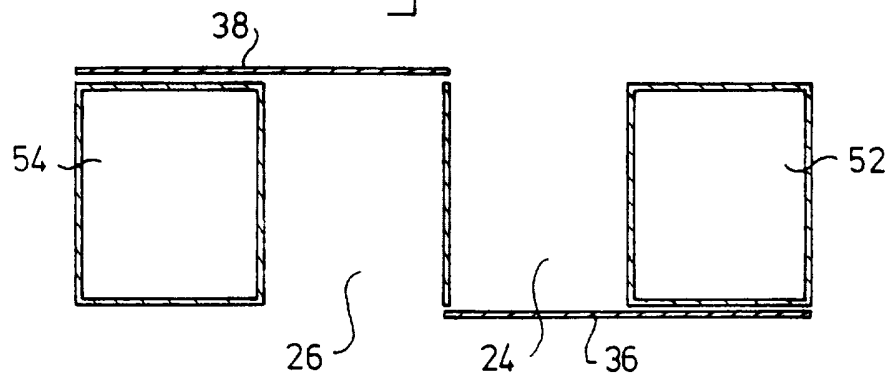

fig-2c

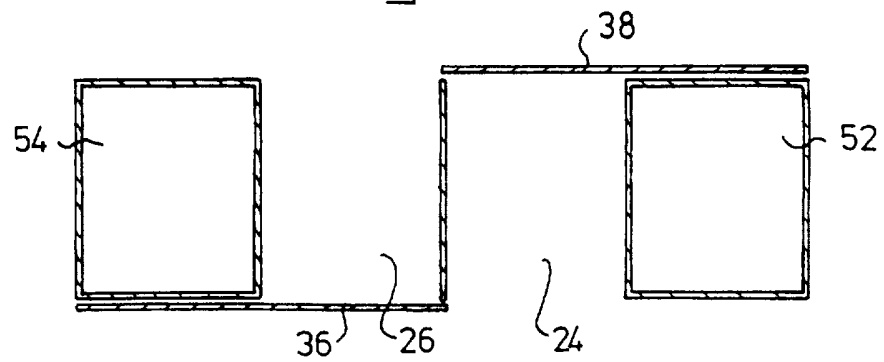
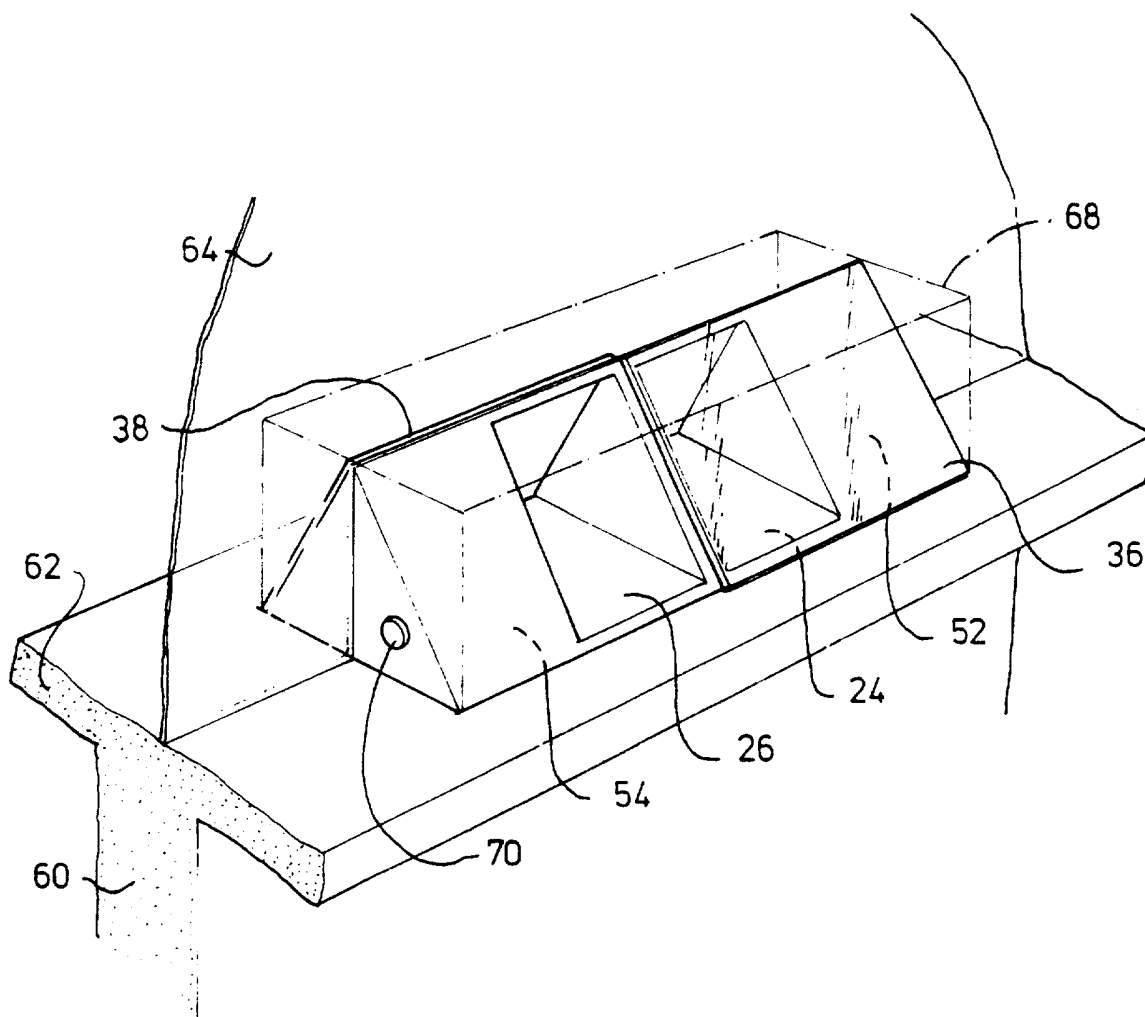

fig-3



INTERNATIONAL SEARCH REPORT

International Application No

PCT/NL 97/00331

A. CLASSIFICATION OF SUBJECT MATTER
IPC 6 E05G7/00

According to International Patent Classification (IPC) or to both national classification and IPC

B. FIELDS SEARCHED

Minimum documentation searched (classification system followed by classification symbols)

IPC 6 E05G A47F A47G

Documentation searched other than minimum documentation to the extent that such documents are included in the fields searched

Electronic data base consulted during the international search (name of data base and, where practical, search terms used)

C. DOCUMENTS CONSIDERED TO BE RELEVANT

Category *	Citation of document, with indication, where appropriate, of the relevant passages	Relevant to claim No.
A	US 1 885 165 A (WILLEMS) 1 November 1932 see figures 3,4 <p style="text-align: center;">-----</p>	1

Further documents are listed in the continuation of box C.

Patent family members are listed in annex.

* Special categories of cited documents :

- *A* document defining the general state of the art which is not considered to be of particular relevance
- *E* earlier document but published on or after the international filing date
- *L* document which may throw doubts on priority claim(s) or which is cited to establish the publication date of another citation or other special reason (as specified)
- *O* document referring to an oral disclosure, use, exhibition or other means
- *P* document published prior to the international filing date but later than the priority date claimed

- *T* later document published after the international filing date or priority date and not in conflict with the application but cited to understand the principle or theory underlying the invention
- *X* document of particular relevance; the claimed invention cannot be considered novel or cannot be considered to involve an inventive step when the document is taken alone
- *Y* document of particular relevance; the claimed invention cannot be considered to involve an inventive step when the document is combined with one or more other such documents, such combination being obvious to a person skilled in the art.
- *&* document member of the same patent family

Date of the actual completion of the international search

29 August 1997

Date of mailing of the international search report

17.09.97

Name and mailing address of the ISA

European Patent Office, P.B. 5818 Patentlaan 2
 NL - 2280 HV Rijswijk
 Tel. (+ 31-70) 340-2040, Tx. 31 651 epo nl,
 Fax (+ 31-70) 340-3016

Authorized officer

Van Kessel, J

INTERNATIONAL SEARCH REPORT

Information on patent family members

International Application No

PCT/NL 97/00331

Patent document cited in search report	Publication date	Patent family member(s)	Publication date
US 1885165 A	01-11-32	NONE	
