

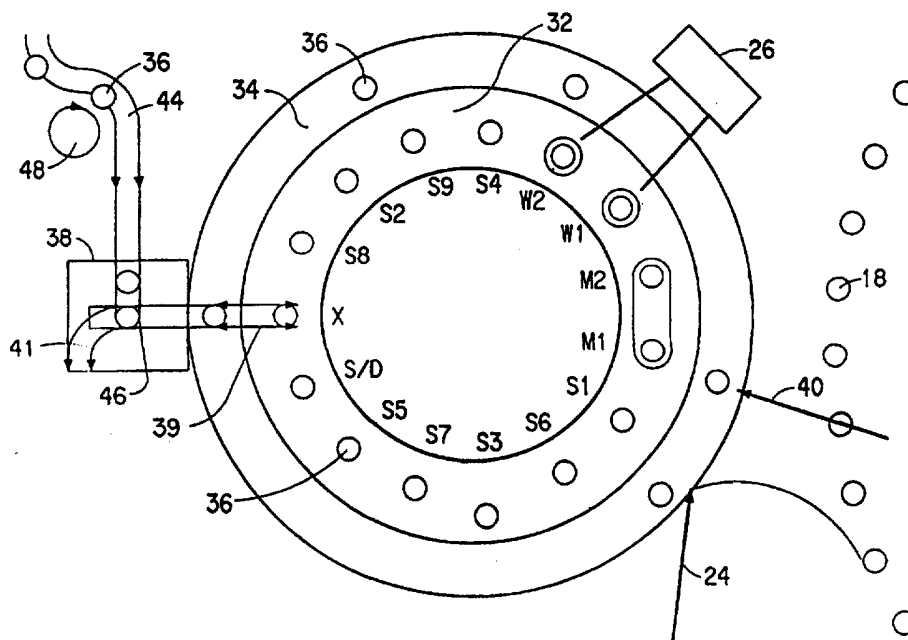

INTERNATIONAL APPLICATION PUBLISHED UNDER THE PATENT COOPERATION TREATY (PCT)

<p>(51) International Patent Classification ⁶ : G01N 35/02, 33/543, 35/04</p>	<p>A1</p>	<p>(11) International Publication Number: WO 97/41445</p> <p>(43) International Publication Date: 6 November 1997 (06.11.97)</p>
<p>(21) International Application Number: PCT/US97/06936</p> <p>(22) International Filing Date: 25 April 1997 (25.04.97)</p> <p>(30) Priority Data: 08/638,618 26 April 1996 (26.04.96) US</p> <p>(71) Applicant: DADE CHEMISTRY SYSTEMS INC. [US/US]; 1717 Deerfield Road, Deerfield, IL 60015 (US).</p> <p>(72) Inventors: KEGELMAN, Joseph, Edward; 112 Gibson Avenue, Wilmington, DE 19803 (US). MIZZER, John, Paul; 956 Devon Drive, Newark, DE 19711 (US). NUZZACI, Edward, Anthony; 10 Persimmon Lane, Newark, DE 19713 (US). CHOW, Allan, Tit-Shing; 109 Banbury Drive, Wilmington, DE 19803 (US).</p> <p>(74) Agents: WINSTON, Lois, K. et al.; 1717 Deerfield Road, Deerfield, IL 60015 (US).</p>		<p>(81) Designated States: JP, European patent (AT, BE, CH, DE, DK, ES, FI, FR, GB, GR, IE, IT, LU, MC, NL, PT, SE).</p> <p>Published <i>With international search report.</i></p>

(54) Title: METHOD AND APPARATUS FOR PRE-TREATING SAMPLES IN AN AUTOMATIC CHEMICAL ANALYZER



(57) Abstract

A pre-processor for use in performing heterogeneous immunoassays on samples for analyses in the sample employing concentrically positioned incubating and processing carousels. A single transfer station permits reaction vessels containing sample and reagents to be moved between the carousels. The samples are separated, washed and mixed on the processing carousel and incubated on the incubating carousel thus speeding up processing throughput.

FOR THE PURPOSES OF INFORMATION ONLY

Codes used to identify States party to the PCT on the front pages of pamphlets publishing international applications under the PCT.

AL	Albania	ES	Spain	LS	Lesotho	SI	Slovenia
AM	Armenia	FI	Finland	LT	Lithuania	SK	Slovakia
AT	Austria	FR	France	LU	Luxembourg	SN	Senegal
AU	Australia	GA	Gabon	LV	Latvia	SZ	Swaziland
AZ	Azerbaijan	GB	United Kingdom	MC	Monaco	TD	Chad
BA	Bosnia and Herzegovina	GE	Georgia	MD	Republic of Moldova	TG	Togo
BB	Barbados	GH	Ghana	MG	Madagascar	TJ	Tajikistan
BE	Belgium	GN	Guinea	MK	The former Yugoslav Republic of Macedonia	TM	Turkmenistan
BF	Burkina Faso	GR	Greece			TR	Turkey
BG	Bulgaria	HU	Hungary	ML	Mali	TT	Trinidad and Tobago
BJ	Benin	IE	Ireland	MN	Mongolia	UA	Ukraine
BR	Brazil	IL	Israel	MR	Mauritania	UG	Uganda
BY	Belarus	IS	Iceland	MW	Malawi	US	United States of America
CA	Canada	IT	Italy	MX	Mexico	UZ	Uzbekistan
CF	Central African Republic	JP	Japan	NE	Niger	VN	Viet Nam
CG	Congo	KE	Kenya	NL	Netherlands	YU	Yugoslavia
CH	Switzerland	KG	Kyrgyzstan	NO	Norway	ZW	Zimbabwe
CI	Côte d'Ivoire	KP	Democratic People's Republic of Korea	NZ	New Zealand		
CM	Cameroon			PL	Poland		
CN	China	KR	Republic of Korea	PT	Portugal		
CU	Cuba	KZ	Kazakstan	RO	Romania		
CZ	Czech Republic	LC	Saint Lucia	RU	Russian Federation		
DE	Germany	LI	Liechtenstein	SD	Sudan		
DK	Denmark	LK	Sri Lanka	SE	Sweden		
EE	Estonia	LR	Liberia	SG	Singapore		

patient sample are mixed with the solid phase in a test tube. In the absence of patient antigen, some 50% of the antigen-tag is bound to the antibody of the magnetic solid phase. In the presence of patient antigen, some of the antibodies are
5 attached to patient antigen and are unavailable to the tag antigen. As a result increasing amounts of patient antigen leads to decreasing amount of tag antigen. Magnetic separation clusters the magnetic particles of solid phase with the bound tag into a pellet on the side of the tube. The free tag can
10 then be removed by thorough washing and aspiration. Following separation and removal of free tag, another reagent is added so that the amount of bound tag can be measured.

In a typical sandwich immunoassay, multiple steps are used, i.e., an antibody to an antigen is attached to the
15 magnetic particle in high concentration relative to the amount of patient antigen in a sample. Patient antigen is captured by the antibody on the magnetic particles and then the particles (with attached or captured patient antigen) are separated from interfering substances in the sample. A second reagent,
20 containing a second antibody with an attached tag, is added. This second antibody attaches to the patient antigen, captured by the first antibody on the magnetic particle, and results in the formation of a sandwich so that the second antibody tag is held firmly by the antigen to the first antibody on the
25 magnetic particle. At this point, a thorough washing and magnetic separation permit the determination of bound tag which is in proportion to the patient antigen, the excess tag of the second reagent having been removed by the washing action.

30 In both types of heterogeneous immunoassays, considerable resources and time are required to achieve a sufficiently high degree of washing so as to eliminate interfering constituents and prevent spurious assay results. The degree to which this is achieved in an automated analyzer is an important
35 contributor to the sensitivity of the analyzer.

High throughput is a desirable feature of such analyzers. An important contributor to maintaining a high throughput is the ability to process a plurality of samples through a variety of the different heterogeneous assay process steps

that are needed before the signal measurement step may be undertaken. These multiple process steps tend to limit throughput. In the design of new automatic analyzers, in particular those involving complex "sandwich" heterogeneous
5 immunoassays, which often require many separate processing operations, the ability to be capable of detecting a wide variety of analyses yet occupy a minimum of physical space, is an important performance advantage. Generally, repetitive, uninterrupted operation enhances throughput since a number of
10 vessels can be processed simultaneously.

Repetitive operation is particularly difficult to achieve in the case of heterogeneous "sandwich" immunoassays. This is a particularly difficult procedure even when performed manually. It is a particular problem when the automatic wash
15 procedure is incorporated into an automatic analyzer which is capable of performing multiple types of immunoassays. This necessitates the use of multiple wash stations and this is typically accomplished in automatic analyzers by providing such multiple wash stations. For example, the sensitivity
20 requirements of some heterogeneous assays demand that the washing efficiency must be very high. This is normally achieved by repeated washes, each successive wash removes unwanted liquids and reagents so that a progressively lower background level is achieved. At the same time, such a washing
25 regimen places limitations on use of the various processing resources since the analyzer is required to be stationary in a washing activity. Nominally, an assay requires a total of four separate washes interlaced with four separation steps. Accordingly, an important design feature of the analyzer is
30 the ability of non-washing resources to be productively involved with one sample while another is being washed. However, the several mechanisms required to operate individually the several wash stations and the mechanisms required for the wash stations themselves can become quite
35 expensive.

U.S. Pat. No. 4,459,265 assigned to Clinicon describes an automatic analytical apparatus with a stepwise rotatable circular plate. It carries a plurality of reaction tubes on its periphery with several reagent supply stations arranged at

different locations around such periphery. The use of multiple stations does provide the machine with the versatility to carry out several different test methodologies, but again does not provide the necessary washing required for heterogeneous immunoassays. The automatic analytical apparatus described in such Clinicon patent, includes a stepwise rotatable circular plate. It carries a plurality of reaction tubes on its periphery with several reagent supply stations arranged at different locations around such periphery. The use of multiple stations does provide the machine with the versatility to carry out several different pre-assay process steps, but again does not provide the necessary washing required for heterogeneous immunoassays.

A conventional chemical analyzer produced by Hitachi, Inc., Tokyo, Japan, Model Number 7050, links together or "gangs" plural wash probes. When this is accomplished, however, the ability of the instrument to perform multiple analytical procedures at the same time is impaired.

U.S. Pat. No. 5,104,808, Laska et al., assigned to the assignee of the present invention, also describes an analyzer which "gangs" wash probes together. The wash probes are ganged together, but also separated into two groups to achieve the goal of providing washed solid support which contains a minimal amount of the original serum/conjugate matrix. According to Laska et al. the wash means includes at least two wash probes coupled or ganged for simultaneous insertion into the reaction vessels at different processing positions. Further, the wash probes are positioned contiguous to the first one of the sample and/or reagent positions in the sequence. The means for adding sample and/or reagents is disabled each cycle for a number of vessels leading and trailing the first and last vessel receiving sample or reagent, the number corresponding to the number of processing positions between the insertable wash probes.

U.S. Patent 5,183,638, Wakatake, discloses an analyzer in which a reaction vessel is conveyed past several devices for adding and agitating magnetic particles as required during a EIA immunoassay.

U.S. Patent 5,192,505, Sakagami, discloses an analyzer in which two different reaction lines are provided, driven by only one driving device, one line adapted to provide for assay operations involved in a colorimetric measurement, the other
5 line adapted to provide for assay operations involved in an immunization agglutination measurement. An advantage of the analyzer is maintainance of a small physical size.

Another feature used in automated analyzers is the scheduling method used to present the sample to the various
10 assay tools. As described in U.S. Pat. No. 5,212,094, an automatic chemical analyzer uses an odd number of reaction vessels disposed in a circular pattern. The reaction vessels are rotated successively half revolutions of the circular pattern plus the distance between reaction tubes. Using such a
15 pattern, it is possible to collectively situate the washing stations proximate one another and thereby facilitate compactness of the analyzer, however such an analyzer is not capable of performing heterogeneous immunoassays.

The analyzer of U.S. Patent No. 5,352,612 includes a
20 movable sample support for holding samples arranged in a first plurality of positions for movement in a first direction. An indexing drive for the sample support moves the samples in the sample support in the first direction in a set of increments wherein each increment represents a movement of the samples an
25 amount corresponding to a number of samples. Such a system enables separation of logical space from physical space in the system, allowing more freedom in placement of mechanical equipment while permitting proper sequencing of operations both in space and in time. This system requires a very complex
30 time-indexing motion of a rotatable sample support that is determined differently for each and every loading of the sample support. As best understood, the movement pattern is determined by the number of pairs of reaction cuvettes. The pattern may vary depending on the assay to be performed and
35 the times spent stopped before different processing resources varies according to the operation of the processing resource.

U.S. Pat. No. 5,380,487, assigned to Pasteur Sanofi Diagnostics, describes an analyzer in which assay resources are assigned fixed operating sequence which begin and end

within a time cycle of fixed duration. When different samples having different assay protocols are entered into the analyzer, assay resource requirements for the different samples are determined and "time slots" of the required resources are allocated thereto. Provision is made for handling heterogeneous assays, however because an incubator belt physically intersects the wash wheel, a complex relationship is established between the indexing time of an incubator belt, the indexing time of a wash wheel, and the cycle time of operations performed on reaction vessels as they are moved along the wash wheel. In addition, the control means must determine which time-based assay resources are required to process a test and then check the availability of those assay resources on a cycle-by-cycle basis against the allocation of the resources to the processing of other tests underway. Absent any conflicts in the allocation of assay resources, processing of a reaction vessel will sequentially follow a preceding reaction vessel. Consequently, initiation of the sample processing for a test may be delayed until all the necessary assay resources are available for processing. Although such scheduling may reduce the overall number of indexing cycles necessary to complete the processing of all the tests, scheduling conflicts do delay processing initiation and also result in processing resources being idled.

From a study of the different approaches taken in the prior art to the problems encountered with automated processing of complex heterogeneous immunoassays, there is a need for improved automated analyzers and associated processes for handling samples. At the same time, there is a need for maintaining a high throughput without introducing complex programming and, at the same time, minimizing the physical size of an analyzer. In particular, there is a need for a method of providing bound-unbound analyte separation and wash in a minimum of processing time, in a pattern that enhances/maintains throughput of an automated analyzer.

It is an object, therefore, of the present invention to provide an apparatus for providing the operations required in heterogeneous immunoassays at an increased efficiency and with greatly simplified sample handling techniques.

SUMMARY OF THE INVENTION

Many of these disadvantages of the prior art are overcome by using the apparatus and/or methods of this invention. This invention provides a method pre-processing samples having a solid support for heterogeneous assays, using a processing carousel and an incubating carousel, for detecting an analyte in said samples, comprising the steps of:

- (a) adding tag reagents, including said solid support, to the sample on said incubating carousel, thereby forming a tagged sample analyte-support complex,
- (b) transferring the sample and reagents to the processing carousel,
- (c) separating the solid support from at least a portion of the sample and reagents,
- (d) washing the solid support,
- (e) mixing the solid support with a wash buffer, and
- (f) transferring the solid support and buffer to the incubation carousel, and
- (g) detecting the an analyte.

The number and sequence of steps is selected so that each reaction vessel transferred onto the processing carousel may be removed from the processing carousel at the transfer station for additional processing and returned to the processing carousel using the single transfer station without interrupting the repeated synchronous pattern.

Such a novel approach makes it possible to achieve the rigorous requirements for washing samples required in heterogeneous immunoassays. This is true even though several tests or assays have different reaction times before a wash and may include a reagent addition and incubation step interlaced within the required wash cycles.

Associated with this method is an automatic sample processor for performing pre-immunoassay operations on samples using a solid support. The processor in an analyzer for detecting an analyte, in a sample, using solid supports, said processor comprising:

a processing carousel supporting a plurality of reaction vessels each adapted to hold a sample,

an incubating carousel, supporting a plurality of reaction vessels each adapted to hold a sample, positioned concentrically of said processing carousel,

stationary processing stations positioned adjacent one of
5 said carousels, said stations having means for separating said solid support from the contents of a reaction vessel, means for washing the contents of a reaction vessel, and means for mixing the contents of a reaction vessel,

drive means to rotate each carousel independently of the
10 others, said processing carousel being driven in a repetitive manner to position each of its reaction vessels to positions contiguous predetermined processing stations, and

transfer means for transferring reaction vessels between
said carousels, thereby improving processing time by
15 permitting the incubation of all reaction vessels on the incubating carousel without interrupting sample processing on the processing carousel.

The processing stations are positioned in a preselected order to permit the processing carousel to position its
20 reaction vessels in a repetitive sequence of separation and the wash steps. More specifically, the reaction vessel repetitive sequence is separation, wash, and mix. These features provide an analyzer that has a high throughput, reduces the cost of the processing stations by locating
25 similar functions together, and permits samples being processed to be removed at virtually anytime for incubation or measurement.

BRIEF DESCRIPTION OF THE DRAWINGS

30 The invention will be more fully understood from the following detailed description thereof taken in connection with the accompanying drawings which form a part of this application and in which:

Figure 1 is a schematic plan view of an automated
35 chemical analyzer having a pre-assay processor with a movable processing carousel, an incubating carousel, and a plurality of processing stations for pre-assay processing of samples;

Figure 2 is a schematic plan view of the pre-assay processor of Fig. 1; and

Figure 3 is a timing diagram for the pre-assay processor.

5 DETAILED DESCRIPTION OF THE PREFERRED EMBODIMENT

The method and apparatus of this invention will be described initially with particular reference to Figs. 1 and 2 of the drawings. Fig. 1 shows schematically the elements of a conventional automatic chemical analyzer 10 comprising a sample cup carousel 12 supporting a plurality of sample cups 14, a cuvette carousel 16, adapted to hold a plurality of cuvettes 18 and to provide plurality of reagent liquid cartridges 20, illustrated as disposed beneath a cut out portion of a lid 22, which covers various thermally controlled areas. Reagent cartridges 20 are preferably a multi-compartmented container such as those sold under the tradename FLEX™ by E.I. du Pont de Nemours and Co., Inc., Wilmington, DE. Cuvettes 18 may be formed, as done on the Dimension® chemical analyzer sold by E.I. du Pont de Nemours and Co., Inc., Wilmington, DE by pulling two different composition ribbons of clear film from a cuvette film cartridge, not shown, onto the periphery of the cuvette carousel 16. The cuvette carousel 16, preferably in the form of a wheel, has about a hundred separate cavities for holding cuvette 18, the inner wall of each cavity having an opening to allow transmission of light. A small opening remains at the top of each cuvette 18 to allow the addition of reagent liquid and sample liquid. A sample liquid arm 24 and a wash resource 26 are located proximate the sample cup carousel 12 and cuvette carousel 16. Sample liquid arm 24 supports a conventional sample liquid probe 28 and is mounted to a rotatable shaft 27 so that movement of sample liquid arm 24 describes an arc intersecting the sample cup carousel 12, the cuvettes 18, and the wash resource 26. The wash resource may be used to clean the probe 28.

A first liquid probe 25 is rotatably mounted above cuvette carousel 16 and is adapted to draw reagent liquid from an appropriate reagent liquid cartridge 20 and deposit each reagent liquid within a predetermined cuvette 18 for

processing by the chemical analyzer 10. Probe 25 further
comprises an ultrasonic mechanism used for aspirating,
dispensing and mixing reagents similar to that used in the
Dimension® chemical analyzer. Since the hydrating, aspirating,
5 dispensing and mixing mechanisms are well known in the art
they need not be described further. Photometric analyzing
means, not shown, located beneath the cuvette carousel 16
measures light absorbance through the cuvettes 18 at various
wavelengths, from which the presence of analyte in the sample
10 liquid may be determined using well-known analytical
techniques. Thus far, the chemical analyzer is conventional
and may be, for example, the Dimension® clinical analyzer sold
by E.I. du Pont de Nemours and Co., Wilmington, Delaware.

This invention adds to that analyzer a pre-assay sample
15 processing module 30. This facilitates the several additional
steps necessary to perform heterogeneous assays without
reducing the ability of the chemical analyzer to maintain a
high sample throughput. The processing module 30 permits
processing either or both of the sample liquid with analyte
20 and/or the reagent liquid, before they are provided to a
cuvette 18 for measurement. Sample processing module 30
comprises two pre-assay sample treatment carousels 32 and 34.
These are an inner processing carousel 32 and an outer
incubation carousel 34, housed in a thermal chamber, (not
25 shown), the two carousels being concentrically mounted with a
common axis and preferably lying in a common plane, both
preferably being in the form of a circular carousel. Both
carousels are independently moveable and have a predetermined
number of vessel holding means which may be clips, not shown,
30 to support a plurality of individual pre-assay reaction
vessels 36.

Drive means 31 are provided for independently rotating
incubation carousel 34 and processing carousel 32 about a
common axis, the drive means typically comprising gear teeth
35 disposed on each of the carousels 32 and 34 and interlacing
with pinion gears mounted on the shaft of a motor (not shown).
The drive means may be of conventional design. The transfer

station 38 described above is one of the plurality of processing stations.

The incubation carousel 34 preferably contains 45 discrete positions, and is situated to allow reaction vessels 36 to be presented for: 1) reagent addition, 2) sample addition/aspiration, and 3) transfer to/from the cuvette and processing carousels 16, 32, and for load/unload. The carousel may be about 10' in diameter. The incubation carousel 34 is driven via a drive means 31 and uses a single home sensor. Its position can be verified at any time via an encoder attached to the stepper motor.

The incubation carousel 34 is slotted to allow vessels to be transferred on/off the carousel horizontally.

When vessels 36 are on the incubation carousel 34, they move inside a thermal incubation trough, which guides the vessels as they travel around the carousel, and keeps them at a steady temperature. The incubation trough is aluminum and heated via a resistive element. A thermistor senses the metal temperature nearest the vessels.

The incubation carousel operation is asynchronous; i.e., it can position any of 45 vessels to any of three locations as noted above at any time. This provides flexibility in assay formats and complete random access.

The processing carousel 32 contains 15 discrete positions, and is situated concentric inside the incubation carousel. The processing carousel allows the vessels to be presented for: 1) magnetic separation, 2) aspirate/wash, 3) re-suspension mixing, and 4) transfer on/off the processing carousel to the incubation carousel. The processing carousel 32 may be about 7' in diameter.

The processing carousel 32 is driven by the drive means 31, by the same as the incubation carousel. Similar to the incubation carousel, the processing carousel is slotted to allow vessels to be transferred on/off. The vessels are held in place on the carousel with spring clips.

Unlike the incubation carousel, the sequencing of the processing carousel is synchronous or repetitive. Whenever reaction vessels 36 are present on the carousel, the carousel

will index in a rote manner, advancing each vessel through a series of separate-wash-mix steps.

Generally, repetitive operation enhances throughput, but places certain restrictions on assay formats and random access
5 capability. Since 15 reaction vessels can occupy the carousel and process simultaneously, throughput is enhanced. However, since the processing carousel operates independent of the incubation carousel, flexible assay formats and complete random access processing is still achieved.

10 The sensitivity requirements of some heterogeneous assays demand that the processing station efficiency must be very high. This invention permits repeated washes of each reaction vessel, in order to ensure the desired near-zero background levels. Nominally, each assay has a total of 4 separate/wash
15 sequences.

A common transfer station 38, which accesses both carousels 32 and 34, is provided for transferring reaction vessels 36 between the two carousels 32 and 34 and for removing reaction vessels 36 from the sample processing module
20 30 and passing them into a suitable waste disposal, not shown.

The transfer station 38 (Fig. 2), which may be of conventional design, is used to transfer reaction vessels 36 to/from the processing carousel and to load/unload vessels from the incubation carousel 34. All vessel transfers are done
25 in the horizontal plane only, by simply sliding the vessels along their path on a slider 39. The slider 39 is driven via a stepper motor, (not shown), and can locate the vessels anywhere along the transfer station 38, i.e., over either of carousels 32 or 34. An encoder is used to verify positioning
30 of the slider. As the design must allow for new vessels to come in and old ones to clear, a 'T' track 46 is employed. A solenoid driven gate (not shown) is closed to allow new vessels to be loaded.

New vessels are routed to the vessel transfer station 38
35 via the feedtrack 44. A drive wheel 48, located at the end of the feedback 44 near the transfer station, is used to provide positive drive of a stack of vessels (not shown) when the system is loading a new vessel into position for transfer onto the incubation carousel 34.

Used vessels are routed to the waste container via a plastic chute 41 attached to the underside of the transfer station, beneath a hole in the exit track (not shown).

A second liquid probe 40 is rotatably mounted above
5 cuvette carousel 16 and is adapted to draw reagent liquid from
an appropriate reagent liquid cartridge 20 and deposit such
reagent liquid in a predetermined reaction vessel 36 in the
incubation carousel 34. Sample liquid probe 28 is also adapted
10 (1) to draw sample liquid from a reaction vessel 36 after the
sample liquid has undergone the scheduled pre-assay operations
and (2) to deposit sample liquid within a predetermined
cuvette 18 for further processing and measurement.

In accordance with this invention, sample processing
devices, or stations 42 (Fig. 1), are positioned at selected
15 circumferential locations about the processing carousel 32
such that they can access reaction vessels 36. It will be
recalled the processing carousel 32 is concentrically mounted
with the incubating carousel 34, radially outside of the
processing carousel 32 (depicted in Fig. 1 as inside for the
20 sake of clarity).

These stations are adapted to provide for mixing together
of the sample liquid and the reagent liquid contained in a
reaction vessel 36, for washing the sample liquid and the
reagent liquid contained in a reaction vessel 36, and for
25 magnetic separation of tagged magnetic particles from free
tags or reagent liquid contained in a pre-assay reaction
vessel 36.

Two wash stations W1 and W2 (Fig. 2) are used to aspirate
away unbound sample and/or reagent from reaction vessels, and
30 possibly replenish the vessel with a wash buffer for
subsequent steps.

The wash station module comprises a casting that holds
two dual wash probes (W1 & W2), allowing two vessels to be
washed concurrently. The probes are spring loaded, which
35 ensures reliable contact with the bottom of each vessel for
complete aspiration. The probes operate on adjacent vessels;
if only one vessel is present, only one probe is
aspirated/dispensed. The probes are positioned up/down via a

stepper motor. The position is verified using a home sensor after each operation.

There are two mix stations M1 and M2 (Fig. 2). They are used to re-suspend the separated magnetic particles in the wash buffer after each wash. The mixer employs a vortex external mixer design, which avoids any contamination with the sample/reagents while mixing. Mixing station M preferably impart a vortexing mixing action to reaction vessels 36 as is a usual practice in the manipulation of samples in chemical laboratories. Devices are available for this purpose and preferably comprise an externally mounted disc which is placed against the bottom of the reaction vessels and eccentrically rotated.

Design of the mix station is conventional, for example, as described in U.S. Patent 4,848,917, Benin et al. assigned to the assignee of the present invention. In a preferred embodiment, external contact is made with the vessel(s) using a mixing pad to engage the vessel bottom tips. The vessel is then wobbled in an eccentric motion, causing the vortex mix. The mixing pad is normally recessed about 0.050 inches below the vessel bottoms, so that the vessel tips will clear while the wash carousel is advancing them between stations. When vessels are in position for a mix, the mixing pad is elevated to make contact with the vessels. The elevation is achieved via swing-out cams, which engage when the mix motor is energized and reaches a certain speed. A sensor is used to detect that the mix pad is properly engaged.

As with the wash stations, the mix stations M1 and M2 can operate on two vessels concurrently. Normally, two adjacent vessels are mixed simultaneously; however, the mixer is capable of mixing either of the two adjacent vessels if the other one is missing.

The separation stations S1 to S9 (Fig. 2) as conventional and typically include magnets positioned adjacent the locations of the reaction vessels 36 for attracting the magnetic solid support particles (such as those described in U.S. 5,104,808) to the walls of the reaction vessel such that unbound material may be aspirated.

Figure 2, as noted, shows various stationary processing stations (described above) disposed contiguous the processing carousel 32. The drive means 31 for controlling movement of carousels 32 and 34 is conventionally controlled by a
5 controlling unit, preferably a microprocessor based central processing unit (CPU), housed in the analyzer 10 to move the vessels index-stepwise to each processing station 42 where at pre-assay processing occurs, as described below. The control is provided by software, typically like that used on the
10 Dimension® clinical chemistry analyzer and is widely used by those skilled in the art of computer-based electromechanical control programming. The rotating means are preferably commercially available stepper motor mechanisms.

In accordance with the present invention, the processing
15 carousel 32 is indexed to successive processing locations or stations 42 capable of performing various pre-assay operation. The samples at each station are subjected to various pre-assay operations for a constant time period. Figure 2 shows the processing carousel 32 preferably associated with pre-assay
20 treatment stations distributed as follows: ten separation stations (S1.....S10), two wash stations (W1, W2), and two mix stations (M1, M2), and the transfer station 38.

The important time-templating features of the processing carousel 32 of the present invention are described next in
25 detail. These are implemented by operating software programs which will be described in conjunction with the Figure 3. It has been discovered that if a particular relationship is established between the number and location of processing stations on processing carousel 32 and the sequence at which
30 reaction vessels 36 are repetitively indexed to processing stations 42 is maintained, then it is possible to significantly increase the efficiency of pre-assay processing of samples undergoing heterogeneous assays. These samples may require either a first reagent addition, sample-support
35 separation, sample mix and sample wash and/or a second reagent addition, a second sample-support separation, a second sample mix and a second sample wash.

In order to achieve the pre-assay protocols associated with these alternate pre-assay requirements, it has been

discovered that one can use repetitive sequences or patterns of movement for each of the reaction vessels 36 to the several processing stations 42, i.e., S, W, and M.

In accordance with this invention, rather than index or
 5 sequence the processing carousel 32 one position at a time, a novel technique is used to advance the vessels unique segments or groups of index positions at a time. The processing carousel 32 has 15 stations, hence there are 15 indexes or positions to index the carousel for a complete revolution. The
 10 advancing is always in the same direction and alternates between incrementing groups of +6 indexes or positions and +7 indexes or positions of the processing wheel (Figs. 2 and 3). Applying this sequence to the processing carousel 32, it can be seen that a reaction vessel 36 entering at "X", the
 15 transfer station, and advancing a total of 30 groups of indexes, would transition through all the stations in this pattern:

TABLE 1

20	X-S-S-S-S-S-W1-X-M1	(first wash)
	-S-S-S-S-W1-S-M1	(second wash)
	-S-S-S-S-W2-S-M2	(third wash)
	-S-S-S-S-W2-S-M2-X	(fourth wash)

25 This sequence provides the needed four separate/wash/remix steps using 30 groups of indexes. Simultaneous assays would use all four washes consecutively. Sequential assays would use the 1st separation/wash steps after the first incubation, and the 2nd, 3rd, and 4th
 30 separation/wash steps after the second incubation.

As depicted in Table 1, above, starting from the point of entry at the transfer station, each and every reaction vessel 36 in processing carousel 32 undergoes a first indexing segment or STEP 1 in which the processing carousel 32 is
 35 indexed counter-clockwise past five intervening processing stations without stopping to the sixth-next processing station S1. Thus, a first reaction vessel at station X is transferred counter-clockwise by a synchronous movement of the inner carousel 32, past five intervening processing stations to the

seventh processing station S1. After the same constant predetermined time of operation, the processing carousel 32 is indexed repetitively counter-clockwise past six intervening processing stations without stopping, to the seventh-next
5 processing station S2. This repetitive pattern of movement of indexing forward first to the sixth-next processing station, followed by sample treatment for a constant predetermined time of operation, and then indexing forward to the seventh-next processing station is repeated with the indexing always in the
10 same direction, forward or counter-clockwise as seen from above, without stopping regardless of the assay to be performed. A reaction vessel 36 on processing carousel 32 thereby experiences a first rotational movement which comprises six carousel step-indexed movements "forward", each
15 indexed segment movement followed by a stopped time at the aligned processing station Mn, Sn, or Wn as indicated for a constant time amount of pre-assay sample treatment. This repetitive pattern of six-seven index segments is repeated as explained below when needed to perform five separate
20 treatments, i.e., single wash and single mix pre-assay processing treatments as in the instance of a "single-reagent" heterogeneous assay. In the instance of a so-called "two-reagent" heterogeneous assay, the reaction vessel 36 may be removed from the processing carousel 32 for additional reagent
25 treatment, as explained below and then re-placed on the processing carousel 32.

Applying this sequence to the processing carousel 32 arrangement as shown in Fig. 2, it can be seen that a vessel entering processing carousel 32 from the transfer station 38,
30 and indexing a total of 30 index segments would make two complete revolutions around the carousel, and would transition through all the required stations before being presented to the transfer station 38 for transfer to the incubation carousel 34 where sample aspiration may occur. This sequence
35 provides four separate wash cycles of separate, wash, and mix cycles using 30 index segments. In the case of a sequential assay, after the first wash cycle is completed, the reaction vessel is located at the transfer station. Certain sequential assays require an additional reagent addition and incubation

period after the initial transfer to incubation carousel 34 and thereafter are transferred back onto processing carousel 32 to complete the separation process, again processing through the second, third and fourth wash cycles as needed.

5 This increased throughput is made possible by using a repetitive movement of the processing carousel 32, in which each of the reaction vessels 36 on the processing carousel 32 are presented to processing stations Sn, Mn and Wn in an ordered manner, each vessel 36 being processed by the station
 10 where it is moved during the synchronous movement of the processing carousel 32, each vessel furthermore being processed by the different devices Sn, Mn, and Wn for a same constant amount of time.

The timing sequence for these wash cycles is shown in
 15 Fig. 3 and the timing sequences is calculated by the CPU of the analyzer 10. Without regard to the express times at the several processing stations 42, the repetitive sequence making up the several wash cycles may be better understood with reference to Table 2. The appropriate choice of the number of
 20 processing stations and devices, in combination with assigning to each processing station a same constant amount of processing time regardless of the capability of the station enables the throughput of processing carousel 32 to exceed normal expectations.

25 Furthermore, in accordance with the present invention, is the ability to handle a plurality of reaction vessels, up to a maximum of fourteen, and present each one of the reaction vessels to the required resource in the required order, the number of resource stations being equal to fifteen stations.

30

TABLE 2

	<u>First Wash Cycle</u>							
Step	1	2	3	4	5	6	7	8
Processing Positions	+6	+7	+6	+7	+6	+7	+6	+7
35 Station 42	S1	S2	S3	S4	S5	W1	X	M1

		<u>Second Wash Cycle</u>						
	Step	9	10	11	12	13	14	15
	Processing Positions	+6	+7	+6	+7	+6	+7	+6
	Station 42	S2	S6	S4	S7	W1	S/D	M1
5		<u>Third Wash Cycle</u>						
	Step	16	17	18	19	20	21	22
	Processing Positions	+7	+6	+7	+6	+7	+6	+7
	Station 42	S8	S6	S9	S7	W2	S/D	M2
		<u>Fourth Wash Cycle</u>						
10	Step	23	24	25	26	27	28	29
	Processing Positions	+6	+7	+6	+7	+6	+7	+6
	Station 42	S8	S1	S9	S3	W2	S5	M2
	Step	30						
	Processing Positions	+7						
15	Station 42	X						

A "dummy station" D is located as shown at the first counter-clockwise location next adjacent the transfer station 38. They are labeled S/D because it has a separation magnet to maintain any magnetic particles in reaction vessels 36 at that station clustered. The presence of and positioning of "dummy station" D enables the use of a repetitive pattern chosen to present each one of the reaction vessels 36 to the required processing station in the required order. As a result of the particular distribution of pre-assay processing stations in a circular pattern, coupled with the particular movement pattern being broken into four cycles, each reaction vessel is sequentially positioned at sub-groups of separate, wash, mix, stations, allowing the ancillary devices (motors, stirring pads, drains, etc.) that support the action of the two wash probes and the mixers to be ganged together for a compact design.

This technique provides:

- reduced carryover potential, as the W1 wash station is used for first 2 washes, and the W2 station for final 2 washes,
- the wash stations and mixers are located adjacent one another, allowing the 2 wash probes and mixers to be ganged together for a compact design,

• increased throughput when processing sequential assay formats that require a 1st phase sample wash and a 2nd phase reagent wash. In addition to achieving the desired result of positioning like processing stations proximate one another, so as to achieve maximum utilization of supporting devices (motors, pumps, common stirring pad, drains, etc.), once the processing carousel 32 is totally full of reaction vessels 36, for example, as would occur during high volume processing, all vessels are being actively used in either a separate or mix station, except for those vessels positioned at either a X or D position. As many as 13 other reaction vessels 36 may be at different stages in the pre-assay treatment positions afforded by the processing carousel 32 and still allow for an additional reaction vessel to be entered onto the carousel, requiring only that the transfer station X be vacant.

The present invention uses a novel positioning and advancement of the reaction vessels 36 to provide increased throughput when processing heterogeneous sequential assay formats which require an initial wash cycle followed by a reagent addition to accomplish tagging of the antibody and then a final wash cycle. A surprising result of this apparatus is the ability to accomplish high throughput for competitive assay formats which require a first and second incubation. Throughput is a function of the assay requirements, the available resources to service these requirements, and how well the resources are scheduled. All of these must be balanced. It has been found that the present invention provides a proper balance of all of these essential elements to provide an optimum throughput, regardless of whether the assay is simultaneous or sequential.

When fully loaded with a maximum of 15 reaction vessels 36, all vessels may be sequentially stepped through the required stages of separation, wash, and mix in an almost continuous fashion without interrupting the sequential stepping motion of processing carousel 32. This feature has been found to provide a significant reduction in processing time over that which would have been required if the pre-assay steps were handled in the more conventional pattern of completing each reaction vessel's 36n pre-assay processing

before starting another and/or of ganging together a small number of reaction vessels for pre-assay treatment.

In a particular embodiment, the pre-assay processing carousel 32 of the present invention is designed and depicted
5 in Fig. 3 to process heterogeneous assays using an index time for each step of the processing carousel 32 of 10.8 sec. Thus for the four wash cycles each including the stations 42 of S, W, and M for the time indicated at each station of a sequential heterogeneous assay, the time required is 30 x 10.8
10 or 324 seconds. Simultaneous assays use the four wash cycles consecutively. Sequential assays use the first wash cycle, then transfer off for incubation, then transfer back for the second, third, and fourth wash cycles.

Because of the sensitivity requirements of modern
15 heterogeneous assays, it is very important that washing be done in a manner that produces very high efficiency as well as minimizing carry-over between vessels. The present invention produces near-zero background levels. This is done by performing two fairly "gross" washes by station W1 at steps 6
20 and 13. This is followed by a third wash in station W2, and a final fourth wash in station W2 to reduce the final background level to a lower value. As the term is used herein, "magnetic particles" or simply "particles responsive to a magnetic field" may be any of those known in the art. They are
25 preferably ferromagnetic and have a small residual magnetism so that little clumping occurs in the absence of a magnetic field. Preferably magnetic particles of the type described by Lau et al. in U.S. Pat. No. 4,661,408, are employed. The separation stations S thereby separate the bound and free
30 phases in order for the mixing process to proceed.

It is to be understood that the embodiments of the invention disclosed herein are illustrative of the principles of the invention and that other modifications may be employed which are still within the scope of the invention.
35 Accordingly, the present invention is not limited to those embodiments precisely shown and described in the specification but only by the following claims.

CLAIMS

What is claimed is:

1. A pre-assay processor in an analyzer for detecting
5 an analyte, in a sample, using solid supports, said processor
comprising:
a processing carousel supporting a plurality of reaction
vessels each adapted to hold a sample,
an incubating carousel, supporting a plurality of
10 reaction vessels each adapted to hold a sample, positioned
concentrically of said processing carousel,
stationary processing stations positioned adjacent one of
said carousels, said stations having means for separating said
solid support from the contents of the reaction vessel, means
15 for washing the contents of a reaction vessel, and means for
mixing the contents of a reaction vessel,
drive means to rotate each carousel independently of the
others, said processing carousel being driven in a repetitive
manner to position each of its reaction vessels to positions
20 contiguous predetermined processing stations, and
transfer means for transferring reaction vessels between
said carousels, thereby improving processing time by
permitting the incubation of all reaction vessels on the
incubating carousel without interrupting sample processing on
25 the processing carousel.
2. The processor set forth in claim 1 wherein the
processing stations are positioned in a preselected order to
permit the processing carousel to position its reaction
30 vessels in a repetitive sequence of separation and then wash
steps.
3. The processor set forth in claim 2 wherein the
reaction vessel repetitive sequence is separation, wash, and
35 mix.
4. The processor set forth in claim 2 wherein the
reaction vessel sequence permits first, second, third, and

fourth wash cycles, each wash cycle providing a sequence of separation, wash, and mix.

5 5. The processor set forth in claim 1 wherein the drive
means for the processing carousel operates position the
vessels at each processing station for the same fixed amount
of time.

10 6. The processor set forth in claim 1 wherein at least
one of the processing stations performs no active function.

15 7. The processor set forth in claim 1 wherein the
processing carousel is radially in between the processing
stations and the incubatory carousel.

 8. The processor set forth in claim 7 wherein the
processing stations are radially inside the processing
carousel.

20 9. The processor set forth in claim 1 wherein the
processing stations are fifteen in number and wherein the
drive mean rotates the processing carousel to position a given
reaction vessel in repetitive sequences of six and then seven
processing stations.

25 10. The processor set forth in claim 9 wherein the types
of processing stations are physically clustered in groups that
have similar functions.

30 11. The processor set forth in claim 10 wherein the
processing stations are positioned in the order of transfer
means, no active function, separate, separate, separate,
separate, separate, mix, mix, wash, wash, separate, separate,
separate, and separate.

35 12. The processor set forth in claim 11 wherein samples
are introduced first into a reaction vessel on said incubation
carousel.

13. A method for pre-processing samples having a solid support for heterogeneous assays, using a processing carousel and an incubating carousel, for detecting an analyte in said samples, comprising the steps of:

- (a) adding tag reagents, including said solid support, to the sample on said incubating carousel, thereby forming a tagged sample analyte-support complex;
- (b) transferring the sample and reagents to the processing carousel;
- (c) separating the solid support from at least a portion of the sample and reagents;
- (d) washing the solid support;
- (e) mixing the solid support with a wash buffer;
- (f) transferring the solid support and buffer to the incubation carousel; and
- (g) detecting the analyte.

14. The method set forth in claim 13 wherein the steps of transferring to the incubation carousel include the step of incubating the sample, and wherein the method of claim 13 also includes transferring the incubated solid support back to the processing carousel.

15. The method set forth in claim 13 which includes repeating steps (c), (d), and (e).

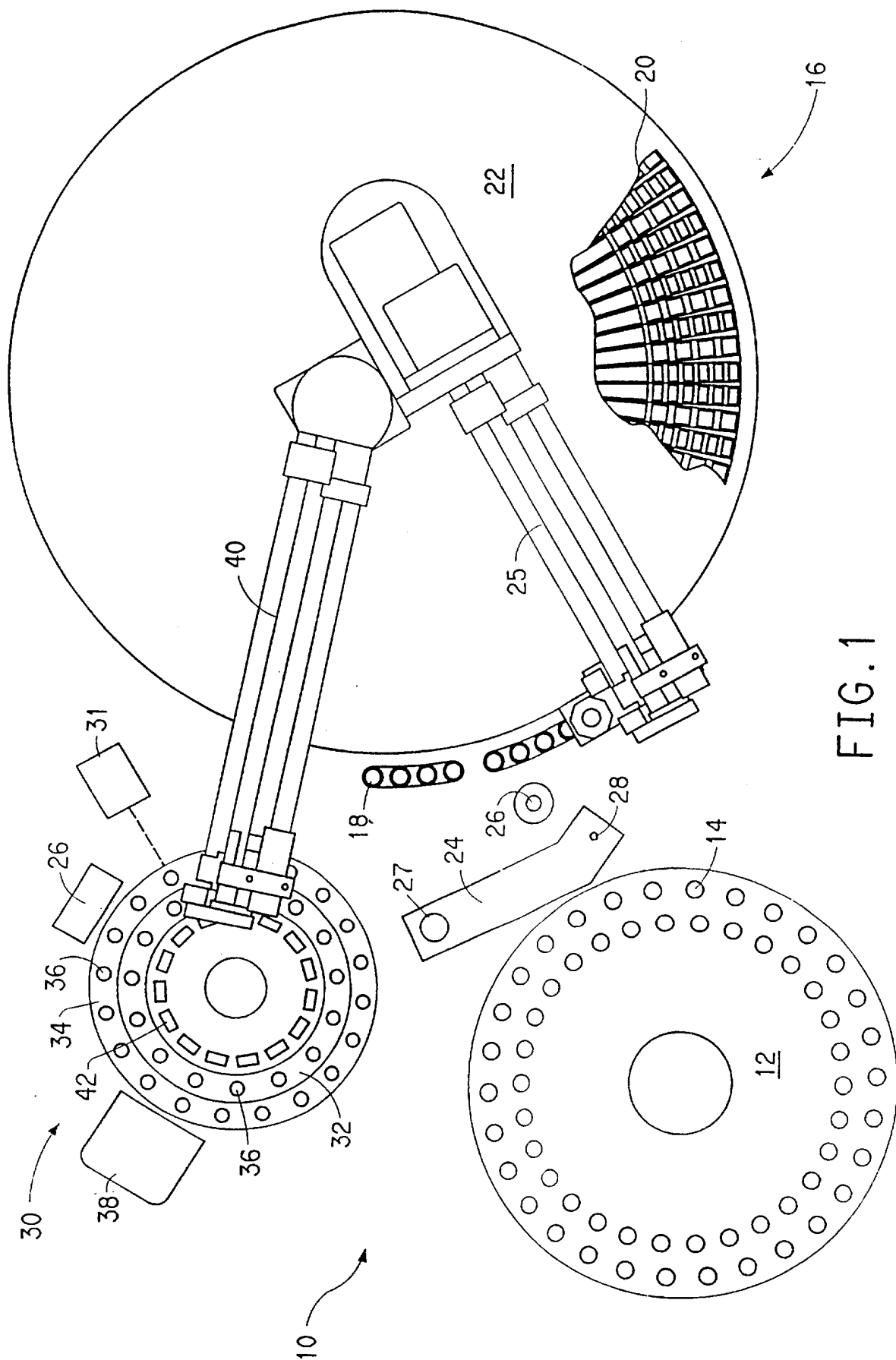

FIG. 1

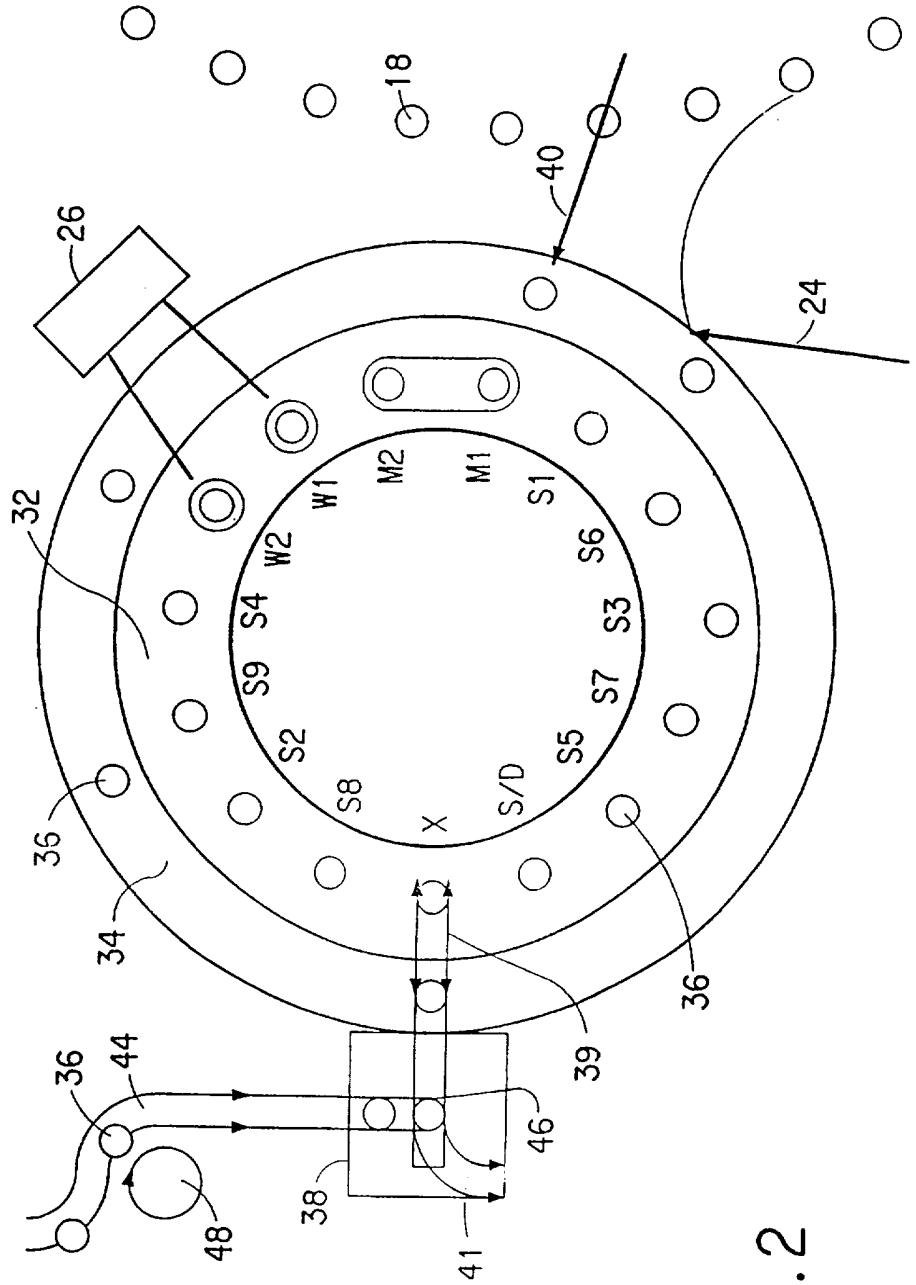

FIG. 2

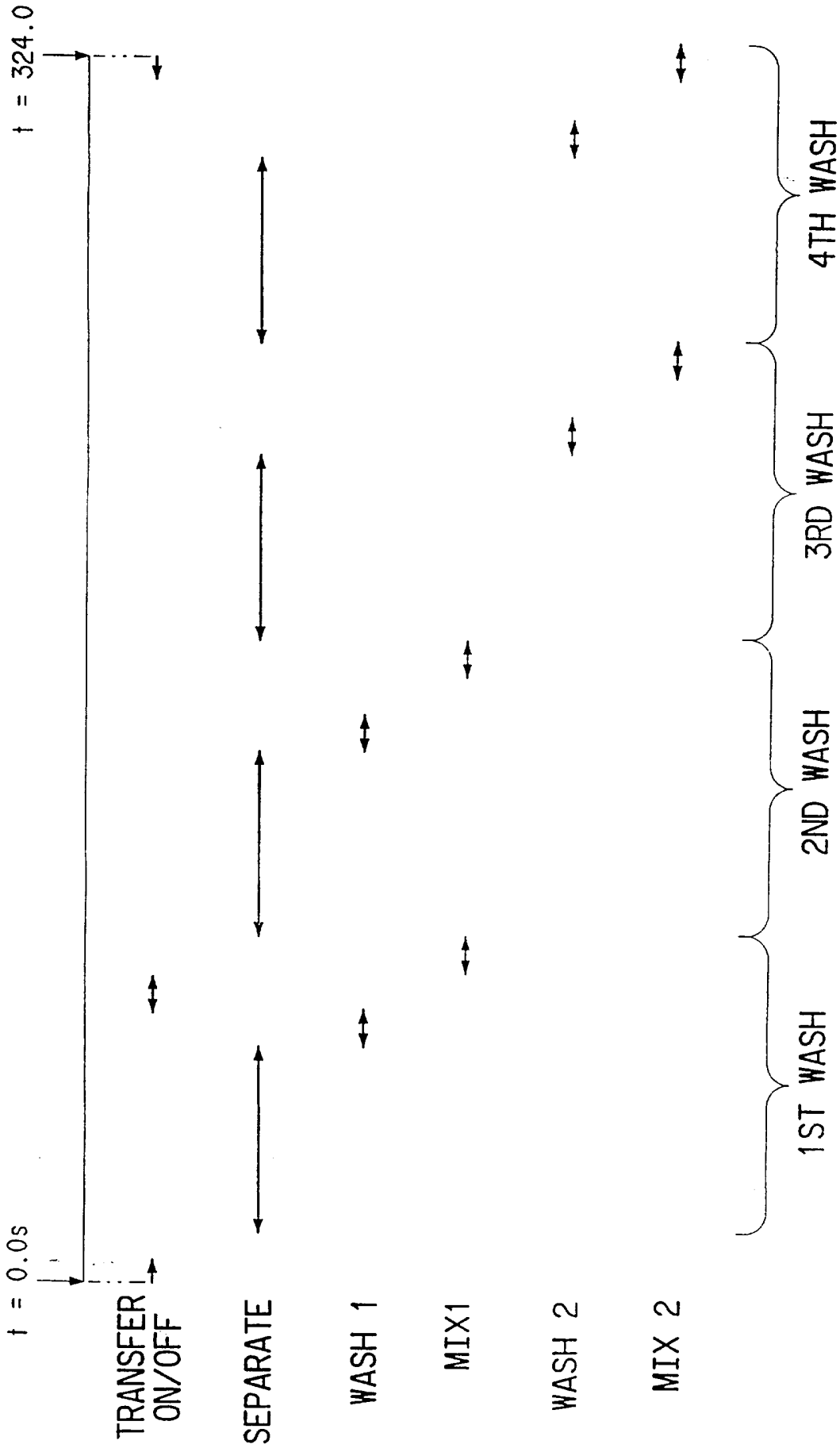

FIG. 3

INTERNATIONAL SEARCH REPORT

International Application No
PCT/US 97/06936

A. CLASSIFICATION OF SUBJECT MATTER
IPC 6 G01N35/02 G01N33/543 G01N35/04

According to International Patent Classification (IPC) or to both national classification and IPC

B. FIELDS SEARCHED

Minimum documentation searched (classification system followed by classification symbols)
IPC 6 G01N

Documentation searched other than minimum documentation to the extent that such documents are included in the fields searched

Electronic data base consulted during the international search (name of data base and, where practical, search terms used)

C. DOCUMENTS CONSIDERED TO BE RELEVANT

Category °	Citation of document, with indication, where appropriate, of the relevant passages	Relevant to claim No.
X	US 5 244 633 A (JAKUBOWICZ RAYMOND F ET AL) 14 September 1993 see column 1, line 19 - line 27 see column 1, line 49 - column 2, line 45 see column 6, line 59 - line 65 see column 7, line 24 - line 34 see column 8, line 8 - line 42 ---	1, 13
A	PATENT ABSTRACTS OF JAPAN vol. 016, no. 186 (P-1347), 7 May 1992 & JP 04 022867 A (TOSHIBA CORP), 27 January 1992, see abstract ---	1
A	US 4 699 766 A (YAMASHITA KIYOSHI) 13 October 1987 see column 4, line 50 - column 5, line 47; figures ---	1
	-/--	

Further documents are listed in the continuation of box C.

Patent family members are listed in annex.

° Special categories of cited documents :

- "A" document defining the general state of the art which is not considered to be of particular relevance
- "E" earlier document but published on or after the international filing date
- "L" document which may throw doubts on priority claim(s) or which is cited to establish the publication date of another citation or other special reason (as specified)
- "O" document referring to an oral disclosure, use, exhibition or other means
- "P" document published prior to the international filing date but later than the priority date claimed

- "T" later document published after the international filing date or priority date and not in conflict with the application but cited to understand the principle or theory underlying the invention
- "X" document of particular relevance: the claimed invention cannot be considered novel or cannot be considered to involve an inventive step when the document is taken alone
- "Y" document of particular relevance: the claimed invention cannot be considered to involve an inventive step when the document is combined with one or more other such documents, such combination being obvious to a person skilled in the art.
- "&" document member of the same patent family

Date of the actual completion of the international search

7 August 1997

Date of mailing of the international search report

14/08/1997

Name and mailing address of the ISA

European Patent Office, P.B. 5818 Patentlaan 2
NL - 2280 HV Rijswijk
Tel. (+31-70) 340-2040, Tx. 31 651 epo nl,
Fax: (+31-70) 340-3016

Authorized officer

Hocquet, A

INTERNATIONAL SEARCH REPORT

International Application No
PCT/US 97/06936

C. (Continuation) DOCUMENTS CONSIDERED TO BE RELEVANT

Category °	Citation of document, with indication, where appropriate, of the relevant passages	Relevant to claim No.
A	EP 0 355 823 A (DU PONT ;HITACHI LTD (JP)) 28 February 1990 cited in the application see page 5, line 21 - page 6, line 8; figures ----	1, 13
A	FR 2 655 426 A (NITTEC CO LTD ;MITSUI PHARMACEUTICALS (JP)) 7 June 1991 cited in the application see page 1, line 29 - page 2, line 28; figures ----	13
A	WO 91 07662 A (BIOTROL SA LAB) 30 May 1991 see page 33; table III ----	13
A	US 5 352 612 A (HUBER MICHAEL D ET AL) 4 October 1994 cited in the application see column 3, line 1 - column 4, line 2 -----	13

INTERNATIONAL SEARCH REPORT

Information on patent family members

International Application No
PCT/US 97/06936

Patent document cited in search report	Publication date	Patent family member(s)	Publication date
US 5244633 A	14-09-93	CA 2095496 A	23-11-93
		EP 0571032 A	24-11-93
		EP 0571034 A	24-11-93
		JP 6034639 A	10-02-94
		JP 6034641 A	10-02-94
US 4699766 A	13-10-87	JP 61274268 A	04-12-86
EP 0355823 A	28-02-90	US 5104808 A	14-04-92
		JP 2269970 A	05-11-90
FR 2655426 A	07-06-91	JP 3175361 A	30-07-91
		GB 2239093 A, B	19-06-91
		IT 1246494 B	19-11-94
		US 5183638 A	02-02-93
WO 9107662 A	30-05-91	FR 2654836 A	24-05-91
		AT 133789 T	15-02-96
		AU 643732 B	25-11-93
		AU 6754890 A	13-06-91
		CA 2044588 A	18-05-91
		CN 1053682 A	07-08-91
		DE 69025175 D	14-03-96
		DE 69025175 T	12-09-96
		EP 0454826 A	06-11-91
		EP 0679891 A	02-11-95
		ES 2027631 T	01-06-96
		IN 171967 A	20-02-93
		JP 4503117 T	04-06-92
		US 5559002 A	24-09-96
US 5352612 A	04-10-94	AU 6238894 A	08-11-94
		EP 0635133 A	25-01-95
		JP 7506197 T	06-07-95
		WO 9424570 A	27-10-94