



(12) **United States Patent**
Kwok et al.

(10) **Patent No.:** **US 10,744,291 B2**
(45) **Date of Patent:** **Aug. 18, 2020**

(54) **POSITIVE-AIR-PRESSURE MACHINE CONDUIT**

(71) Applicant: **ResMed Pty Ltd**, Bella Vista, New South Wales (AU)

(72) Inventors: **Philip Rodney Kwok**, Sydney (AU); **Donald Darkin**, Sydney (AU)

(73) Assignee: **ResMed Pty Ltd**, Bella Vista (AU)

(*) Notice: Subject to any disclaimer, the term of this patent is extended or adjusted under 35 U.S.C. 154(b) by 0 days.

(21) Appl. No.: **16/386,518**

(22) Filed: **Apr. 17, 2019**

(65) **Prior Publication Data**

US 2019/0240439 A1 Aug. 8, 2019

Related U.S. Application Data

(60) Continuation of application No. 16/006,209, filed on Jun. 12, 2018, which is a division of application No. (Continued)

(30) **Foreign Application Priority Data**

Apr. 15, 2004 (AU) 2004902020

(51) **Int. Cl.**
A61M 16/06 (2006.01)
A61M 16/08 (2006.01)

(52) **U.S. Cl.**
CPC **A61M 16/0666** (2013.01); **A61M 16/0611** (2014.02); **A61M 16/0683** (2013.01); (Continued)

(58) **Field of Classification Search**
CPC .. A61M 16/0683; A61M 16/08; A61M 16/06; A61M 16/0666; A61M 16/0672; (Continued)

(56) **References Cited**

U.S. PATENT DOCUMENTS

1,632,449 A 7/1924 McKesson
1,710,160 A 2/1925 Gibbs
(Continued)

FOREIGN PATENT DOCUMENTS

AU 712236 4/1999
AU 2008906390 12/2008
(Continued)

OTHER PUBLICATIONS

International Preliminary Report on Patentability, International Application No. PCT/AU2005/000539, (dated Oct. 19, 2006), 6 pgs.

(Continued)

Primary Examiner — Rachel T Sippel

(74) *Attorney, Agent, or Firm* — Nixon & Vanderhye P.C.

(57) **ABSTRACT**

A nasal assembly for delivering gas under positive pressure to a patient for treatment of sleep disordered breathing includes an air connector to be connected to an air supply tube for delivering a supply of gas. The air connector is to be positioned on top of the head. A nasal interface engages the patient's nose to direct the breathable gas to the patient's nose. A pair of flexible side portions support the nasal interface in a desired position on the patient's face. Each side portion has a conduit with a top portion and a bottom portion. Each conduit is arranged between the patient's eye and ear. A central portion joins the top portions of the conduits. The air connector is pivotally connected to each of the supply tube and the central portion.

66 Claims, 7 Drawing Sheets

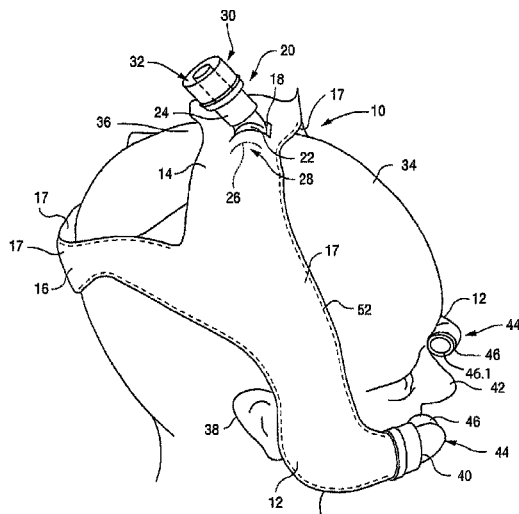

Related U.S. Application Data

15/607,224, filed on May 26, 2017, now Pat. No. 10,029,062, which is a continuation of application No. 11/578,293, filed as application No. PCT/AU2005/000539 on Apr. 15, 2005, now abandoned.

(52) **U.S. Cl.**

CPC *A61M 16/08* (2013.01); *A61M 16/0833* (2014.02); *A61M 2016/0661* (2013.01); *A61M 2205/0238* (2013.01)

(58) **Field of Classification Search**

CPC A61M 16/0677; A61M 2016/06; A62B 18/00; A62B 18/02; A62B 18/08; A62B 18/84; A62B 9/00; A62B 7/00; A62B 7/02; A62B 7/12; A62B 7/14

See application file for complete search history.

(56)

References Cited

U.S. PATENT DOCUMENTS

1,878,464 A 9/1932 Bulmer
 2,126,755 A 8/1938 Dreyfus
 2,130,555 A 9/1938 Malcom
 2,228,218 A 1/1941 Schwartz
 2,376,871 A 5/1945 Fink
 2,578,007 A 12/1951 Hill
 2,578,621 A 12/1951 Yant
 2,706,983 A 4/1955 Matheson et al.
 2,763,263 A 9/1956 Ellman
 2,931,358 A 4/1960 Sherdan
 3,172,407 A 3/1965 Von Pechmann
 3,291,127 A 12/1966 Eimer et al.
 3,330,273 A 7/1967 Bennett
 3,424,633 A 1/1969 Corrigan et al.
 3,799,164 A 3/1974 Rollins
 3,802,431 A 4/1974 Farr
 3,850,171 A 11/1974 Ball et al.
 3,865,106 A 2/1975 Palush
 4,052,984 A 10/1977 Brockway
 4,062,359 A 12/1977 Geaghan
 4,258,710 A 3/1981 Reber
 4,266,540 A 5/1981 Panzik et al.
 4,278,082 A 7/1981 Blackmer
 4,367,735 A * 1/1983 Dali A61M 16/0683
 128/203.22
 4,422,456 A 12/1983 Tiep
 4,437,462 A 3/1984 Piljay et al.
 4,437,463 A 3/1984 Ackerman
 4,463,755 A 8/1984 Suzuki
 4,676,241 A 6/1987 Webb et al.
 4,774,946 A 10/1988 Ackerman
 4,782,832 A 11/1988 Trimble et al.
 4,820,289 A 4/1989 Coury et al.
 4,878,491 A 11/1989 McGilvray, III
 4,919,128 A 4/1990 Kopala et al.
 4,944,310 A 7/1990 Sullivan
 5,018,519 A 5/1991 Brown
 5,042,478 A 8/1991 Kopala et al.
 5,062,421 A 11/1991 Burns et al.
 5,065,756 A 11/1991 Rapoport
 D322,318 S 12/1991 Sullivan
 5,117,819 A 6/1992 Servidio et al.
 5,148,802 A 9/1992 Sanders et al.
 5,205,832 A 4/1993 Tuman
 5,243,971 A 9/1993 Sullivan et al.
 5,269,296 A 12/1993 Landis
 5,477,852 A 12/1995 Landis et al.
 5,538,000 A 7/1996 Rudolph
 5,560,354 A 10/1996 Berthon-Jones et al.
 5,644,807 A 7/1997 Battistella
 5,647,358 A 7/1997 Vilasi
 5,657,752 A 8/1997 Landis et al.
 5,662,101 A 9/1997 Ogden et al.

5,701,892 A 12/1997 Bledstein
 5,724,965 A 3/1998 Handke et al.
 5,746,201 A 5/1998 Kidd
 5,765,557 A 6/1998 Wartens
 5,782,501 A * 7/1998 Brandt F16L 37/0925
 285/81
 5,795,312 A 8/1998 Dye
 5,921,239 A 7/1999 McCall et al.
 5,937,851 A 8/1999 Serowski et al.
 5,989,235 A 11/1999 Quacquarella et al.
 6,016,804 A 1/2000 Gleason et al.
 6,112,746 A 9/2000 Kwok et al.
 6,119,693 A 9/2000 Kwok et al.
 6,119,694 A 9/2000 Correa et al.
 6,192,886 B1 2/2001 Rudolph
 6,357,440 B1 3/2002 Hansen et al.
 6,412,488 B1 7/2002 Barnett et al.
 6,431,172 B1 8/2002 Bordewick
 6,435,181 B1 8/2002 Jones, Jr. et al.
 6,457,473 B1 10/2002 Brostrom et al.
 6,467,483 B1 10/2002 Kopacko et al.
 6,478,026 B1 11/2002 Wood
 6,530,373 B1 3/2003 Patron et al.
 6,561,190 B1 5/2003 Kwok et al.
 6,561,191 B1 5/2003 Kwok et al.
 6,581,594 B1 6/2003 Drew et al.
 6,584,976 B2 7/2003 Japuntich et al.
 6,615,832 B1 9/2003 Chen
 6,631,718 B1 10/2003 Lovell
 6,684,882 B1 2/2004 Morine
 6,691,707 B1 2/2004 Gunaratnam et al.
 6,698,427 B1 3/2004 Clowers
 6,796,308 B2 9/2004 Gunaratnam et al.
 6,823,865 B2 11/2004 Drew et al.
 6,823,869 B2 11/2004 Raje et al.
 6,851,425 B2 2/2005 Jaffre et al.
 6,863,069 B2 3/2005 Wood
 6,892,729 B2 5/2005 Smith et al.
 6,907,882 B2 6/2005 Ging et al.
 7,007,696 B2 3/2006 Palkon et al.
 7,080,645 B2 7/2006 Genger et al.
 7,086,422 B2 8/2006 Huber et al.
 7,104,491 B2 9/2006 Vinding
 7,178,525 B2 2/2007 Matula, Jr. et al.
 7,178,526 B2 2/2007 McDonald et al.
 7,178,528 B2 2/2007 Lau et al.
 7,210,481 B1 5/2007 Lovell et al.
 7,219,669 B1 5/2007 Lovell et al.
 7,302,950 B2 12/2007 Berthon-Jones et al.
 7,318,437 B2 1/2008 Gunaratnam et al.
 7,353,827 B2 4/2008 Geist
 7,357,136 B2 4/2008 Ho et al.
 7,658,189 B2 2/2010 Davidson et al.
 7,827,990 B1 11/2010 Melidis et al.
 7,856,982 B2 12/2010 Matula, Jr. et al.
 7,942,148 B2 5/2011 Davidson et al.
 8,443,807 B2 5/2013 McAuley et al.
 8,479,741 B2 7/2013 McAuley et al.
 8,714,157 B2 5/2014 McAuley et al.
 8,944,061 B2 2/2015 D'Souza et al.
 8,950,404 B2 2/2015 Formica et al.
 8,960,196 B2 2/2015 Henry
 9,027,556 B2 5/2015 Ng et al.
 9,119,931 B2 9/2015 D'Souza et al.
 9,162,034 B2 10/2015 Veliss et al.
 9,242,062 B2 1/2016 Melidis et al.
 9,333,315 B2 5/2016 McAuley et al.
 9,381,316 B2 7/2016 Ng et al.
 9,517,317 B2 12/2016 McAuley et al.
 9,539,405 B2 1/2017 McAuley et al.
 9,907,922 B2 3/2018 Stephenson et al.
 9,907,923 B2 3/2018 Stephenson et al.
 9,974,914 B2 5/2018 McAuley et al.
 2002/0005198 A1 1/2002 Kwok et al.
 2002/0020416 A1 2/2002 Namey
 2002/0029780 A1 3/2002 Frater et al.
 2002/0055685 A1 5/2002 Levitsky et al.
 2002/0092527 A1 7/2002 Wood
 2002/0096173 A1 7/2002 Berthon-Jones et al.

(56)

References Cited

FOREIGN PATENT DOCUMENTS

| U.S. PATENT DOCUMENTS | | | FOREIGN PATENT DOCUMENTS | | | |
|-----------------------|-----|---------|-----------------------------|----|----------------|---------|
| 2002/0108613 | A1 | 8/2002 | Gunaratnam et al. | AU | 2009900327 | 1/2009 |
| 2003/0005934 | A1 | 1/2003 | Japuntich et al. | AU | 2009902731 | 6/2009 |
| 2003/0029454 | A1 | 2/2003 | Gelinas et al. | AU | 2009904236 | 9/2009 |
| 2003/0034030 | A1 | 2/2003 | Carlucci et al. | DE | 100 51 891 | 5/2002 |
| 2003/0094178 | A1 | 5/2003 | McAuley et al. | DE | 101 05 383 | 8/2002 |
| 2003/0164170 | A1 | 9/2003 | Drew et al. | EP | 0 697 225 A2 | 2/1996 |
| 2003/0196655 | A1 | 10/2003 | Ging et al. | EP | 1 027 905 | 8/2000 |
| 2003/0196658 | A1 | 10/2003 | Ging et al. | EP | 1 147 782 | 10/2001 |
| 2003/0200970 | A1* | 10/2003 | Stenzler A61M 16/0666 | EP | 1 149 603 A2 | 10/2001 |
| | | | 128/207.18 | EP | 1 314 445 A | 5/2003 |
| | | | | EP | 1 396 277 A2 | 10/2004 |
| | | | | JP | 2000-507887 | 6/2000 |
| 2004/0003811 | A1 | 1/2004 | Bodner | WO | 1998/024499 | 6/1998 |
| 2004/0016432 | A1 | 1/2004 | Genger et al. | WO | 1998/024499 | 11/1998 |
| 2004/0025882 | A1 | 2/2004 | Madaus et al. | WO | 00/50122 A1 | 8/2000 |
| 2004/0025885 | A1 | 2/2004 | Payne | WO | 2000/076568 | 12/2000 |
| 2004/0041342 | A1 | 3/2004 | Frieman | WO | 2001/032250 | 5/2001 |
| 2004/0060562 | A1 | 4/2004 | McDonald et al. | WO | 2001/062326 | 8/2001 |
| 2004/0065330 | A1* | 4/2004 | Landis A61M 16/06 | WO | 02/47749 A1 | 6/2002 |
| | | | 128/207.18 | WO | 2004/022147 A1 | 3/2004 |
| | | | | WO | 2004/041341 A1 | 5/2004 |
| 2004/0067333 | A1 | 4/2004 | Amarasinghe | WO | 2004/041342 A1 | 5/2004 |
| 2004/0118406 | A1 | 6/2004 | Lithgow et al. | WO | 2004/073778 A1 | 9/2004 |
| 2004/0149280 | A1* | 8/2004 | Semeniuk A61M 16/0683 | WO | 2005/018523 A2 | 3/2005 |
| | | | 128/201.22 | WO | 2005/021075 A1 | 3/2005 |
| | | | | WO | 2005/051468 A1 | 6/2005 |
| 2004/0182398 | A1 | 9/2004 | Sprinkle et al. | WO | 2005/076874 A3 | 8/2005 |
| 2004/0186405 | A1 | 9/2004 | Pinna et al. | WO | 2005/079726 A1 | 9/2005 |
| 2004/0211428 | A1 | 10/2004 | Jones, Jr. et al. | WO | 2005/086943 A2 | 9/2005 |
| 2004/0226566 | A1 | 11/2004 | Gunaratnam et al. | WO | 2005/099801 A1 | 10/2005 |
| 2004/0234610 | A1 | 11/2004 | Hall et al. | WO | 2005/123166 A1 | 12/2005 |
| 2004/0255949 | A1 | 12/2004 | Lang et al. | WO | 2006/000046 A1 | 1/2006 |
| 2005/0001152 | A1 | 1/2005 | Stewart et al. | WO | 2006/074515 A1 | 7/2006 |
| 2005/0011524 | A1 | 1/2005 | Thomlinson et al. | WO | 2006/130903 A1 | 12/2006 |
| 2005/0025816 | A1 | 2/2005 | Tanaka | WO | 2007/006089 A1 | 1/2007 |
| 2005/0028822 | A1 | 2/2005 | Sleeper et al. | WO | 2007/014088 A2 | 2/2007 |
| 2005/0061326 | A1 | 3/2005 | Payne, Jr. | WO | 2007/045008 A1 | 4/2007 |
| 2005/0066976 | A1* | 3/2005 | Wondka A61M 16/06 | WO | 2007/048174 A1 | 5/2007 |
| | | | 128/207.18 | WO | 2007/147088 A2 | 12/2007 |
| | | | | WO | 2008/007985 A1 | 1/2008 |
| 2005/0092326 | A1 | 5/2005 | Drew et al. | WO | 2008/011682 A1 | 1/2008 |
| 2005/0092329 | A1* | 5/2005 | Sta-Maria A61M 16/06 | WO | 2008/011683 A1 | 1/2008 |
| | | | 128/207.18 | WO | 2008/030831 A2 | 3/2008 |
| | | | | WO | 2008/068966 A1 | 6/2008 |
| 2005/0121030 | A1 | 6/2005 | Bateman et al. | WO | 2009/026627 A1 | 3/2009 |
| 2005/0155604 | A1 | 7/2005 | Ging et al. | WO | 2009/052560 A1 | 4/2009 |
| 2005/0199242 | A1* | 9/2005 | Matula, Jr. A61M 16/06 | WO | 2009/059353 A1 | 5/2009 |
| | | | 128/207.13 | WO | 2010/066004 A1 | 6/2010 |
| | | | | | | |
| 2005/0205096 | A1 | 9/2005 | Matula, Jr. et al. | | | |
| 2006/0042629 | A1 | 3/2006 | Geist | | | |
| 2006/0060200 | A1 | 3/2006 | Ho et al. | | | |
| 2006/0112962 | A1 | 6/2006 | Tebbutt et al. | | | |
| 2006/0118117 | A1 | 6/2006 | Berthon-Jones et al. | | | |
| 2006/0124131 | A1 | 6/2006 | Chandran et al. | | | |
| 2006/0174889 | A1 | 8/2006 | Noble | | | |
| 2006/0180151 | A1 | 8/2006 | Rinaldi | | | |
| 2006/0201514 | A1 | 9/2006 | Jones et al. | | | |
| 2006/0272646 | A1 | 12/2006 | Ho et al. | | | |
| 2007/0044804 | A1 | 3/2007 | Matula, Jr. et al. | | | |
| 2007/0045152 | A1 | 3/2007 | Kwok et al. | | | |
| 2007/0074723 | A1 | 4/2007 | Coury et al. | | | |
| 2007/0175480 | A1 | 8/2007 | Gradon et al. | | | |
| 2007/0246043 | A1 | 10/2007 | Kwok et al. | | | |
| 2008/0000477 | A1 | 1/2008 | Huster et al. | | | |
| 2008/0006277 | A1 | 1/2008 | Worboys et al. | | | |
| 2008/0110464 | A1 | 5/2008 | Davidson et al. | | | |
| 2009/0044808 | A1 | 2/2009 | Guney et al. | | | |
| 2010/0236552 | A1 | 9/2010 | Kwok et al. | | | |
| 2011/0072553 | A1 | 3/2011 | Ho | | | |
| 2014/0083430 | A1 | 3/2014 | Matula, Jr. et al. | | | |
| 2017/0266404 | A1 | 9/2017 | Kwok et al. | | | |
| 2018/0289914 | A1 | 10/2018 | Kwok et al. | | | |
| 2019/0184124 | A1 | 6/2019 | Kwok et al. | | | |
| 2019/0184125 | A1 | 6/2019 | Kwok et al. | | | |
| 2019/0192801 | A1 | 6/2019 | Kwok et al. | | | |
| 2019/0192802 | A1 | 6/2019 | Kwok et al. | | | |

OTHER PUBLICATIONS

Supplementary Search Report issued in EP 05 72 9680 dated Sep. 18, 2009.

Office Action issued in CN 200580011118.3 dated Nov. 27, 2009.

Examination Report issued in NZ 550423 dated Mar. 13, 2009.

Instruction Brochure for "E-vent-N" Aug. 1997, © Dräger Medizintechnik GmbH, 2 pages.

European Search Report for PCT/EP2004/007599, dated Dec. 17, 2004, 10 pages.

U.S. Appl. No. 10/563,857, filed Jan. 9, 2006, Madaus et al.

U.S. Appl. No. 60/640,184, filed Dec. 2004, Henry et al.

Examination Report for Co-Pending NZ Application No. 583929, dated Mar. 22, 2010, 3 pages.

Office Action for co-pending JP Application No. 2007-507626, dated Sep. 7, 2010, 4 pages, with English translation.

Examination Report for corresponding NZ Appln No. 583929, dated Sep. 20, 2011, 2 pages.

Decision of Rejection and English Translation for corresponding JP Appln. No. 2007-507626, dated Sep. 20, 2011, 4 pages.

Office Action issued in related CN Appln. No. 200580011118.3 (dated Feb. 22, 2012).

Office Action issued in a corresponding Japanese Application No. 2011-047484 (dated Aug. 7, 2012) with English translation thereof.

Further Examination Report dated Dec. 18, 2012 issued in corresponding New Zealand Application No. 595133.

(56)

References Cited

OTHER PUBLICATIONS

Office Action issued in a corresponding Japanese Application No. 2012-009839 (dated Feb. 5, 2013) with English translation thereof. First Examination Report issued in corresponding Indian Patent Application No. 6006/DELNP/2006 dated Feb. 2, 2013.

Decision of Rejection (with English-language translation) issued in a corresponding Japanese Patent Application No. 2011-047484 dated Jul. 2, 2013.

Non-final Office Action issued in related U.S. Appl. No. 10/563,857 dated Oct. 7, 2013.

Decision of Rejection issued in a corresponding Japanese Application No. 2012-009839 dated Dec. 24, 2013 with English-language translation.

International Search Report for PCT/AU2005/000539 dated Jun. 21, 2005.

Appeal Decision dated Jul. 7, 2014 in corresponding Japanese Patent Application No. 2011-47484 with English translation thereof. Examiner's Answer dated Jun. 3, 2015, in a related U.S. Appl. No. 10/563,587 (27 pages).

Office Action for co-Pending EP Application No. 05729680.8, dated Jul. 19, 2010 (6 pages).

Examiner Report for Co-Pending AU Application No. 2005232337, dated Mar. 31, 2010 (2 pages).

U.S. Appl. No. 11/645,582, filed Dec. 2006, Kwok et al.

U.S. Appl. No. 11/417,234, filed May 2006, Huber et al.

U.S. Appl. No. 10/364,358, filed Feb. 2003, Kwok et al.

U.S. Appl. No. 10/298,845, filed Nov. 2002, Kwok et al.

ACP Composites—Large Stock of Ready to Use Composite Plate, Tube, Sheet, Fabrics and Core Materials, <https://www.acpsakes.com/Core-Materials-nd-Foam.html>, dated Oct. 5, 2015, 4 pages.

Flexifit instructions, <http://web.archive.org/web/19970126045828/http://www.archive.org/> dated Jan. 26, 1997, Affidavit of Christopher Butler dated Sep. 6, 2016, 23 pages.

Guidelines for Sandwich Core Materials, http://fibreglast.com/product/guidelines-for-sandwich-core-materials/Learning_Center, dated Oct. 5, 2015, 3 pages.

<http://pdf.medicaexpo.com> [online], "Opus Brochure," Fisher & Paykel Healthcare, available on or before Apr. 25, 2015, via Internet Archive: Wayback Machine URL <<https://web.archive.org/web/20150425003833/http://pdf.medicaexpo.com/pdf/fisher-paykel-healthcare/opus-specification-sheet/70844-126507.html>> [retrieved on Apr. 30, 2019], retrieved from: URL <www.fphcare.com>, 18 pages.

Malloy, Plastic Part Design for Injection Molding, New York: Hanser Publishers, 1994, 14 pages.

ResMed Mask Frames, Nasal Cushions and Headgear, <http://web.archive.org/web/19970126045828/http://www.archive.org/> dated Jan. 26, 1997, Affidavit of Christopher Butler dated Jul. 6, 2017, 8 pages.

ResMed Mirage Swift Nasal Pillows System, www.resmed.com, 2004, 6 pages.

ResMed Mirage Vista Nasal Mask-Component Cards, www.resmed.com Reference No. 1010279/30502, dated 2005, 1 page.

ResMed Origins Brochure dated Apr. 17, 2016, 64 pages.

Ultra Mirage Full Face Mask brochure, <http://web.archive.org/web/19970126045828/http://www.archive.org/> dated Jan. 26, 1997, Affidavit of Christopher Butler dated Sep. 6, 2016, 9 pages.

Users Guide ResMed Mirage Swift Nasal Pillows System, www.myresmed.com dated May 6, 2004, 11 pages.

Kwok et al, U.S. Appl. No. 16/280,625, filed Feb. 20, 2019 for "Positive-Air-Pressure Machine Conduit," downloaded May 14, 2020, 2394 pages.

Kwok et al, U.S. Appl. No. 16/283,218, filed Feb. 22, 2019 for "Positive-Air-Pressure Machine Conduit," downloaded May 18, 2020, 2364 pages.

Kwok et al, U.S. Appl. No. 16/287,040, filed Feb. 27, 2019 for "Positive-Air-Pressure Machine Conduit," downloaded May 14, 2020, 2366 pages.

Kwok et al, U.S. Appl. No. 16/290,377, filed Mar. 1, 2019 for "Positive-Air-Pressure Machine Conduit," downloaded May 14, 2020, 2370 pages.

* cited by examiner

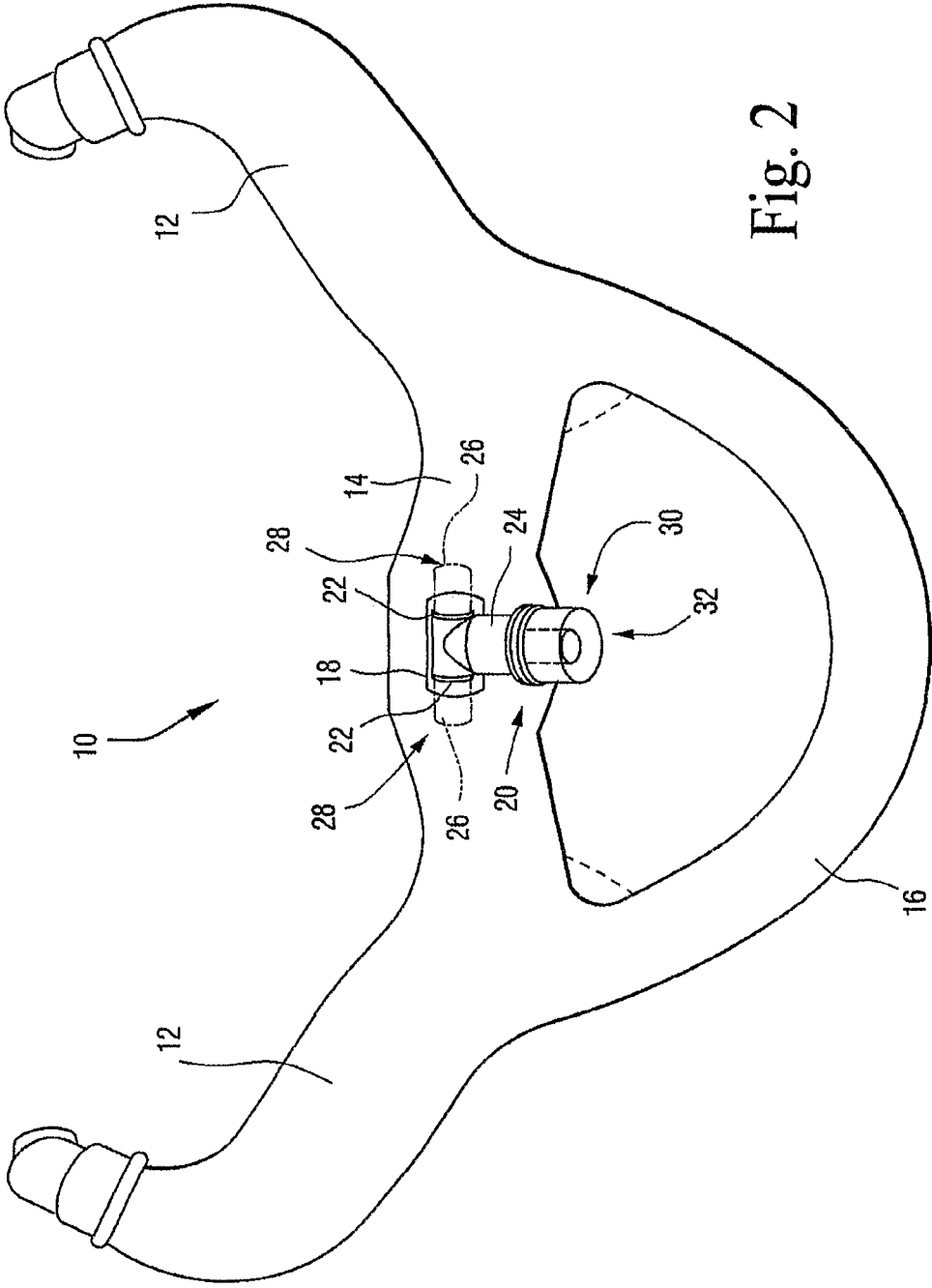

Fig. 2

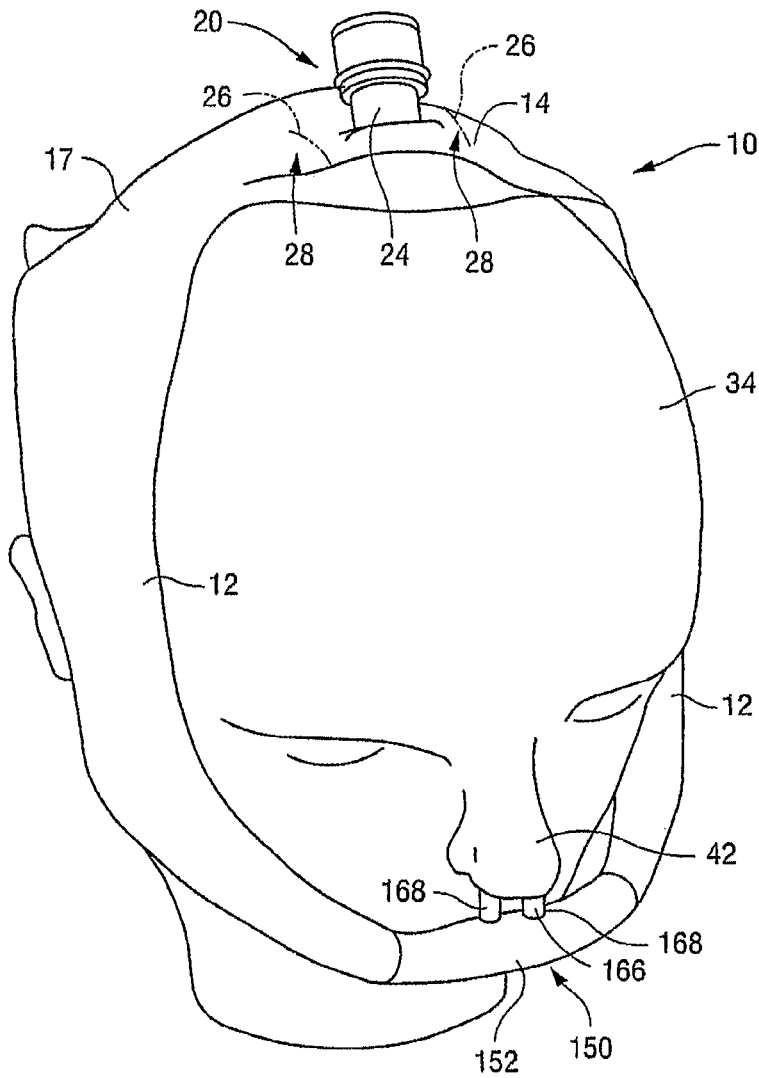

Fig. 3

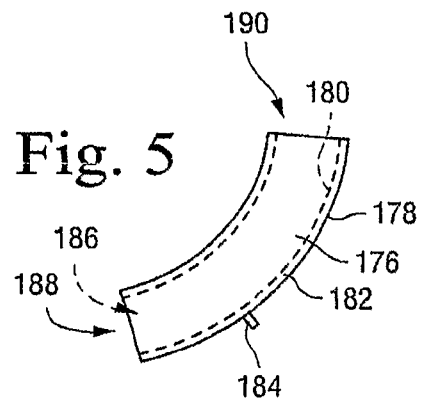

Fig. 5

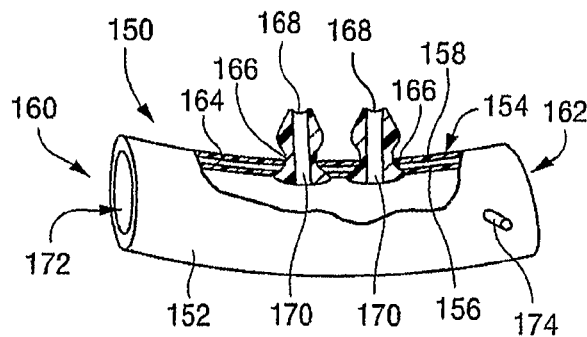

Fig. 4

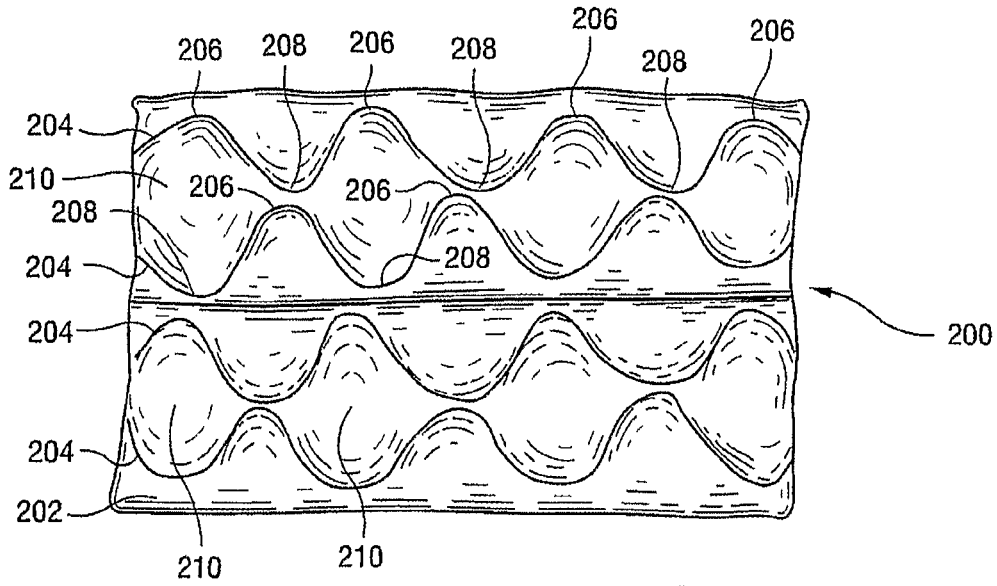

Fig. 7

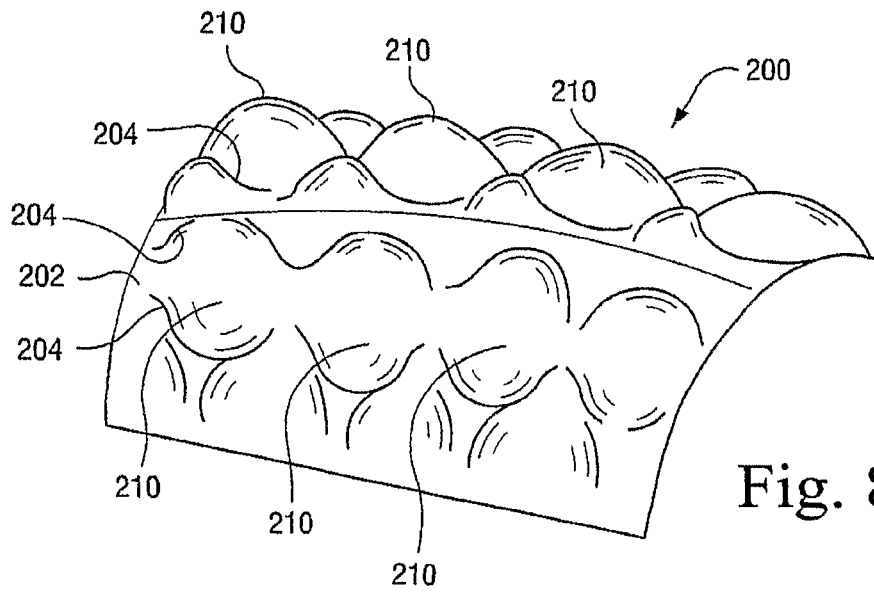

Fig. 8

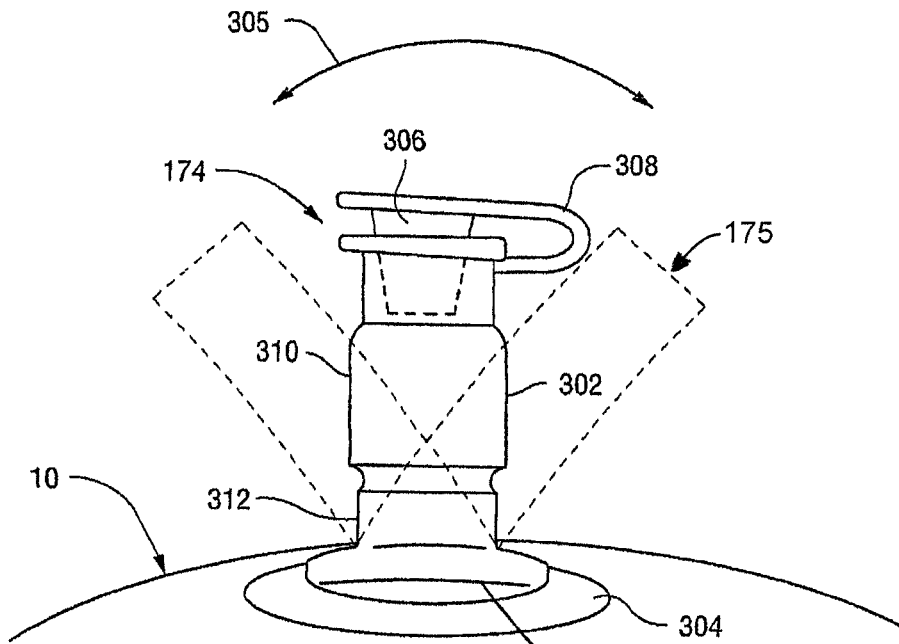

Fig. 9

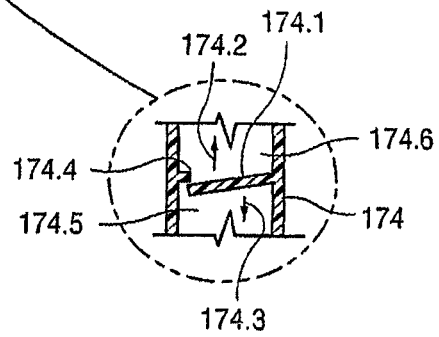

Fig. 9A

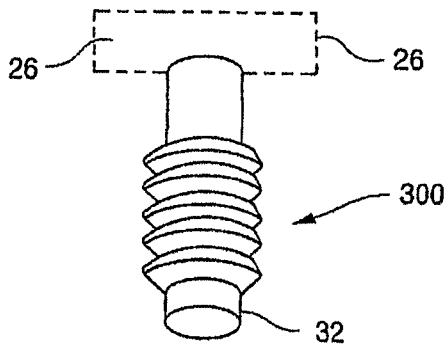

Fig. 10

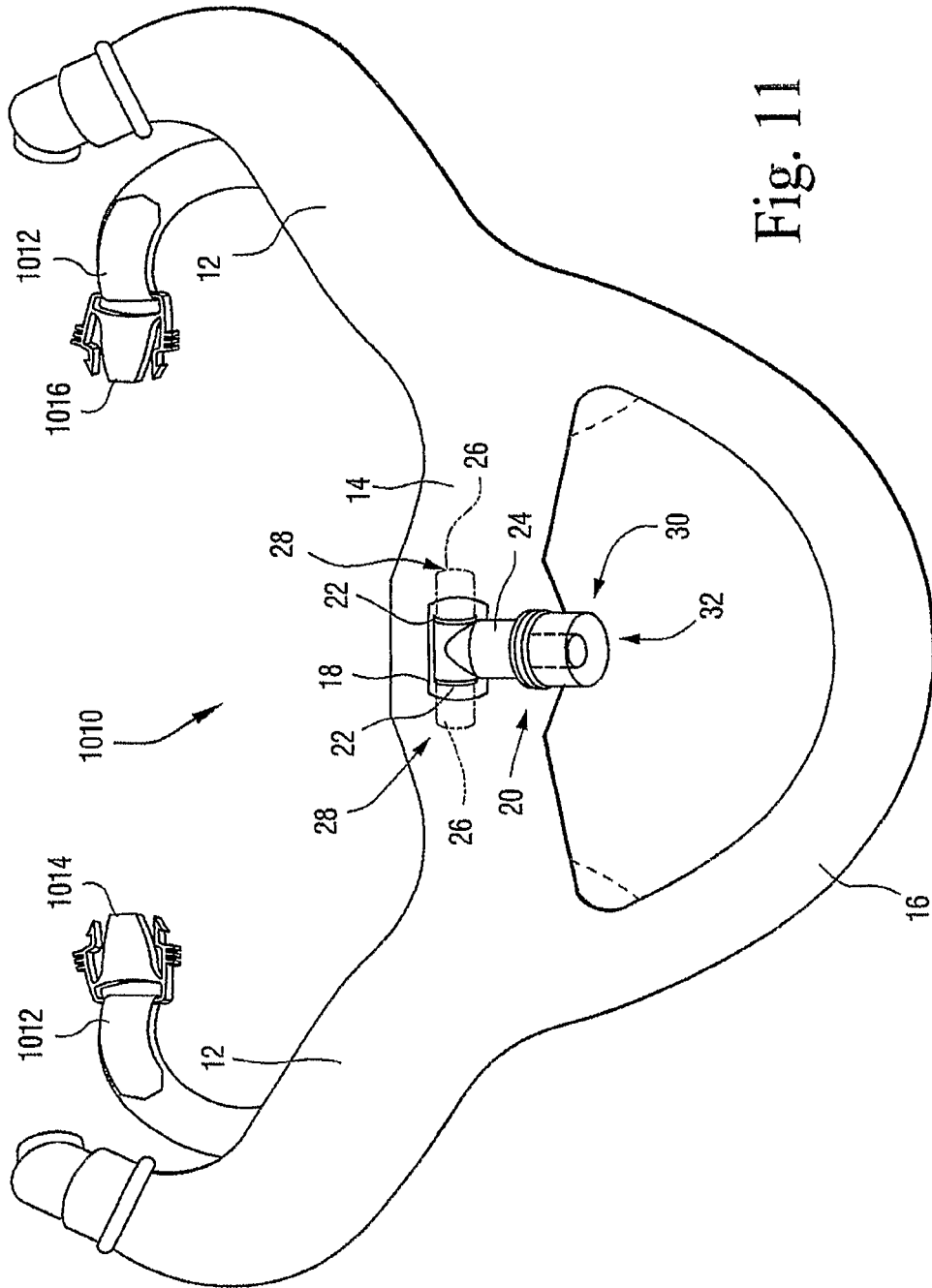

Fig. 11

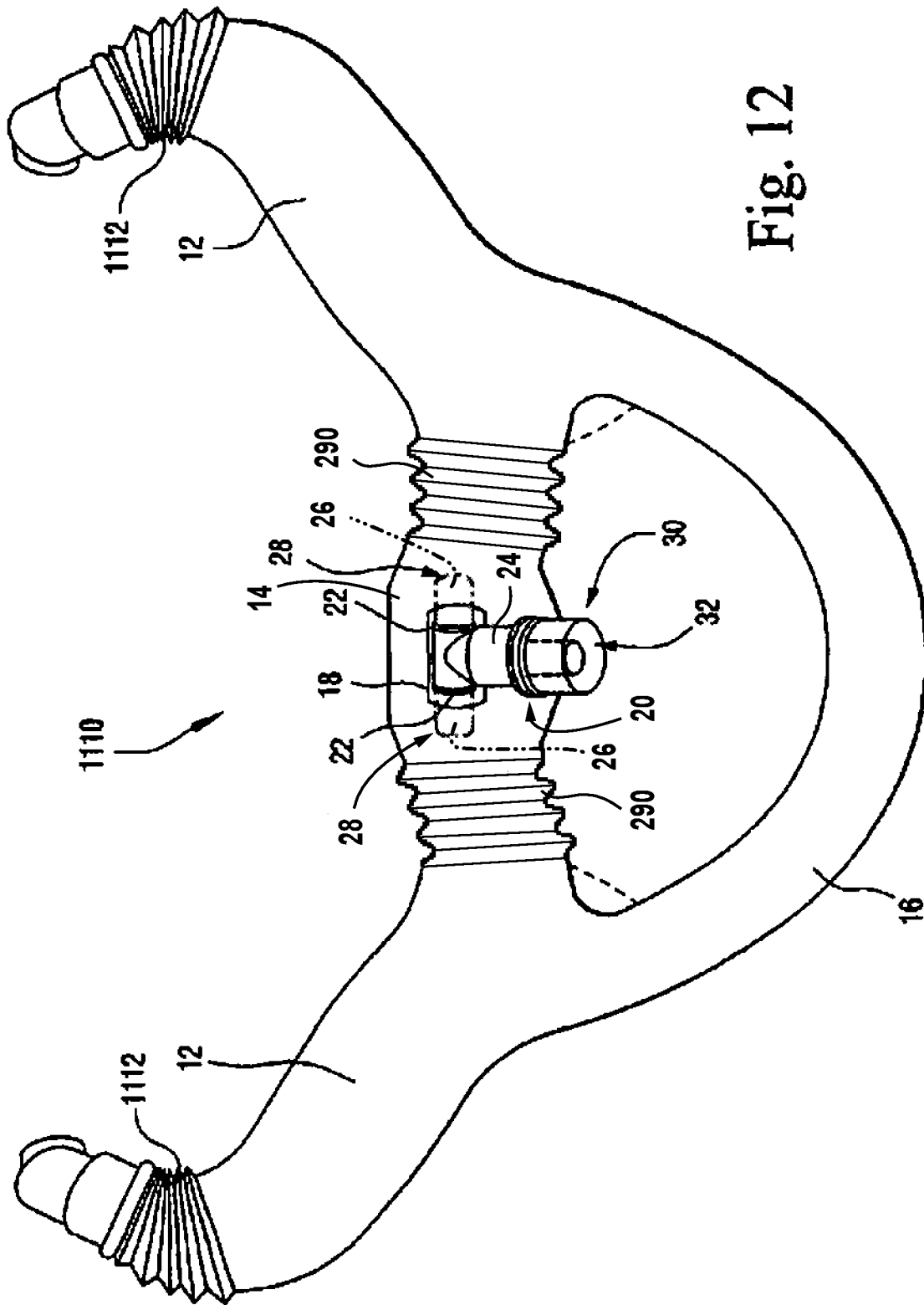

Fig. 12

POSITIVE-AIR-PRESSURE MACHINE CONDUIT

CROSS-REFERENCE TO APPLICATIONS

This application is a continuation of U.S. application Ser. No. 16/006,209, filed Jun. 12, 2018, which is a divisional application of U.S. application Ser. No. 15/607,224, filed May 26, 2017, which is a continuation of U.S. application Ser. No. 11/578,293, filed Oct. 13, 2006, which is the US national phase of international application PCT/AU2005/000539 filed Apr. 15, 2005, which designated the U.S. and claimed the benefit of AU 2004902020 filed Apr. 15, 2004, the entire contents of each of which are hereby incorporated herein by reference.

FIELD OF THE INVENTION

The present invention relates to a positive-air-pressure (PAP) machine conduit. The present invention also relates to headgear including such a conduit and to nose pieces including such a conduit.

BACKGROUND OF THE INVENTION

One of the main factors influencing the success or failure of a patient to adopt a CPAP apparatus used in the treatment of obstructive sleep apnea is the patient's ability to handle the discomfort of the headgear and supply conduit associated with such apparatus.

Such apparatus can tend to limit a patient's ability to move or roll during sleep, thus adding to the potential discomfort for a patient.

Therefore, a need has developed in the art to overcome or ameliorate at least some of the disadvantages of such apparatus, or to provide a useful alternative.

SUMMARY OF THE INVENTION

One aspect of the invention relates to a conduit for delivering a supply of gas under a positive pressure. The conduit includes a conduit wall having a first conduit end and a second conduit end. The first conduit end is adapted to be attached to the supply of gas. The conduit wall is deformable between (a) an open condition in which the conduit wall defines a conduit passage along which the supply of gas can travel between the first conduit end to the second conduit end, and (b) a collapsed condition in which the conduit wall substantially collapses the conduit passage.

Another aspect of the invention relates to headgear for delivering a supply of gas under a positive pressure to a patient. The headgear includes a connector adapted to be attached to the supply of gas. A pair of side portions are adapted to extend along opposite sides of the patient's head. Each of the side portions defines a conduit having a first conduit end attached to the connector and a second conduit end adapted to be positioned adjacent the patient's nose. A head attachment structure is adapted to releasably secure the headgear to the patient's head.

Another aspect of the invention relates to a nasal assembly for delivering a supply of gas under a positive pressure to a patient. The nasal assembly includes a connector adapted to be attached to the supply of gas, a nose-piece adapted to engage the patient's nose, and a pair of side portions adapted to extend along opposite sides of the patient's head. Each of the side portions defines a conduit having a first conduit end attached to the connector and a

second conduit end adapted to connect to the nose-piece. A head attachment structure is adapted to releasably secure the headgear to the patient's head.

Another aspect of the invention relates to a method for using a conduit to deliver a supply of gas under a positive pressure. The method includes providing a conduit including a conduit wall having a first conduit end and a second conduit end. The conduit wall is deformable between (a) an open condition in which the conduit wall defines a conduit passage along which the supply of gas can travel between the first conduit end to the second conduit end, and (b) a collapsed condition in which the conduit wall substantially collapses the conduit passage. The method includes connecting the first conduit end of the conduit to the supply of gas, delivering the supply of gas into the conduit via the first conduit end such that the supply of gas urges the conduit wall into the open condition to allow the supply of gas to travel from the first conduit end to the second conduit end, and disposing the second conduit end of the conduit at a position at which the supply of gas is to be delivered.

Another aspect of the invention relates to a method for constructing headgear that delivers a supply of gas under a positive pressure to a patient. The method includes providing headgear including at least one conduit that defines a conduit passage along which the supply of gas can travel, mapping the shape of a particular patient's head, and forming the headgear into a headgear shape in accordance with the mapping such that the headgear achieves a substantially close and comfortable fit on the particular patient's head.

Another aspect of the invention relates to a positive-air-pressure (PAP) machine conduit. The conduit includes flexible conduit walls, a first conduit end adapted for attachment to a supply of gas under a positive pressure, and a second conduit end. The conduit is configured such that when the first end is connected to the supply, the gas urges the conduit walls into a first condition in which the walls define a conduit passage along which the gas travels from the first end to the second end. The conduit is deformable into a second condition in which the passage is substantially collapsed.

In an embodiment, the conduit may be formed from a single piece of sheet material.

In another embodiment, the conduit may be formed from at least two pieces of sheet material which are joined together.

In another embodiment, the conduit may be formed from woven sheet material. In yet another embodiment, the conduit may be formed from flexible polymeric sheet material, which in an embodiment may be an elastic material.

In another embodiment, the material may a lamination of a plurality of materials. In forms of this embodiment, the material may be a lamination of a thin foam layer and a fabric layer which, in one form, is coated on the foam layer, or felt flocking which, in one form, is coated on the foam layer. Such embodiments may provide a soft, warm comfortable feel against the skin of a patient using the conduit.

In another embodiment, parts of the conduit which are adapted to be in contact with the skin of a patient may be of gel-like material.

In yet another embodiment, the conduit walls may be configured to permit the leaking of gas therethrough from the passage.

In yet another embodiment, the conduit walls may include wall portions in the form of double walls defining a substantially gas tight space between them.

In still another embodiment, the conduit walls may be substantially devoid of elasticity. In another embodiment,

the conduit walls may have elasticity so as to be expandable. In yet further embodiments, the conduit walls may have at least one region with elasticity and at least one other region substantially devoid of elasticity, and/or different regions of differing amounts of elasticity.

Another aspect of the invention relates to a positive-air-pressure (PAP) headgear. The headgear includes connection means for connection in fluid-flow communication to a supply of gas configured for providing gas under a positive pressure and a pair of conduits according to above-noted aspects of the invention or embodiments thereof. The conduits are configured to extend around opposite sides of a patient's head. The first end of each conduit is connected in fluid-flow communication to the connection means and the second end of each conduit is configured, when the headgear is being worn by the patient, to be positioned adjacent the patient's nose. Head attachment means releasably secures the headgear to the patient's head.

In an embodiment, the second end may be configured to be connected to a nose-piece for directing gas that has passed along the passages from the second ends to within the patient's nose.

In another embodiment, the headgear may be configured, when the headgear is being worn by the patient, for the conduits to extend across the patient's nose. The headgear may define a pair of apertures opening into the conduits and positioned to be adjacent the patient's nose for attachment of at least one nose-piece for directing gas that has passed along the passages to within the patient's nose.

In this case, in one embodiment, the second ends may be integrally joined to each other.

Also in this case, the headgear may be provided with a pair of seal rings, each joined to the headgear at a respective aperture for establishing a close seal with the at least one nose-piece.

In another embodiment, the material from which each conduit is formed may be adapted to permit the passage of water vapour therethrough to enhance patient comfort particularly in a warm climate, but is substantially air tight.

In another embodiment, the head attachment means may include a strap joined to at least one of the pair of conduits.

In another embodiment, the pair of conduits and at least part of the connection means may be integral with one another in a unitary construction.

In another embodiment, the pair of conduits, at least part of the connection means, and the strap are integral with one another in a unitary construction.

In yet another embodiment, the headgear may be configured such that the strap extends around a portion of the head posterior to the apex.

In yet another embodiment, the headgear may be configured such that, when the headgear is being worn by the patient, the connection means may be disposed at a position adjacent to or anterior of the apex of the patient's head.

In an embodiment, the headgear may be configured such that, when the connection means is connected in fluid-flow communication to a supply of gas with the supply of gas providing gas under a positive pressure so that the gas travels along the pair of conduits, collapsing of the passage of one of the conduits due to compression being applied to that conduit, which collapsing results in a decrease in the volume flow rate of gas through that passage, results in a deformation of the passage of the other conduit and an associated increase in volume flow rate of gas through the passage of that other conduit.

The headgear may be configured such that, as a result of the deformation of the passage of the other conduit, the total

volume flow rate of the gas through the pair of conduits remains substantially constant during the collapsing of the passage of the one conduit.

In an embodiment, the collapsing of the passage of the one conduit is deformation which causes a change in the ratio between a height extent and a lateral extent of that passage. In one embodiment, the height extent decreases and the lateral extent increases. Similarly, in another embodiment, the deformation of the passage of the other conduit is deformation which causes a change in the ratio between a height extent and a lateral extent of that passage. In one embodiment, the height extent increases and the lateral extent decreases.

In another embodiment, the headgear may include an adjustable head cap with the conduits being attached to the cap at opposite sides thereof. In this case, the cap may constitute the attachment means, and the connection means may be mounted on the cap.

In yet another embodiment, the conduits may be detachable from the attachment means so that the attachment means may be selectively releasably connected with differently sized and/or shaped conduits. In this case, the conduits may be selectively releasably connected with differently sized and/or shaped attachment means, whereby the headgear may form part of a modular headgear system having interchangeable attachment means and conduits.

In an embodiment, the headgear may be adapted for use with a patient mask configured to fit the patient's head adjacent the patient's nose to direct gas from the conduits to the nose. Then, the headgear may be adapted to be detachable from the mask to enable the patient to selectively remove the mask from the headgear and hence from the patient's head while the headgear continues to be being worn by the patient.

Yet another aspect of the invention relates to a nose-piece configured for attachment to a headgear, according to above-noted aspects of the invention or embodiments thereof, for directing air from the second end of a conduit to the interior of the patient's nose.

In an embodiment, the nose-piece may include a conduit according to above-noted aspects of the invention or embodiments thereof.

In another embodiment, the flexible conduit walls may be double walls defining a substantially gas-tight space between them.

In another embodiment, the nose-piece may include a nozzle opening into the space to enable the delivery of gas into the space to inflate the nose-piece.

In another embodiment, the nose-piece may be a conduit according to above-noted aspects of the invention or embodiments thereof.

In another embodiment, the nose-piece may include a pair of nostril formations for being received in a patient's nose and for directing gas from the conduit passage into the nose. Then, in an embodiment, the conduit may define a pair of nostril formation apertures, each nostril formation extending through a respective nostril formation aperture.

In another embodiment, the nostril formations may be customized to closely fit the nostrils of a particular patient.

In yet another embodiment, parts of the headgear which are adapted to be in contact with the skin of a patient may be of gel-like material.

Still another aspect of the invention relates to a method of using a PAP machine conduit, according to above-noted aspects of the invention or embodiments thereof, for delivering air. The method includes connecting the first end of the conduit to a supply means configured for supplying air under

5

a positive pressure, delivering air by the machine to the conduit via the first end such that the air urges the conduit walls into the first condition, and disposing the second end at a position at which the air is to be delivered such that the air that has passed along the passage exits the conduit at the second end.

Still another aspect of the invention relates to a method of providing a PAP headgear for use by a particular patient. The headgear includes connection means for connection in fluid-flow communication to a supply of gas configured for providing gas under a positive pressure, a pair of conduits configured to extend around opposite sides of the particular patient's head, and head attachment means to releasably secure the headgear to the particular patient's head. Each conduit has flexible conduit walls, a first conduit end connected in fluid-flow communication to the connection means, and a second conduit end configured, when the headgear is being worn by the particular patient, to be positioned adjacent the particular patient's nose. Each conduit is configured such that when the connection means is connected to the supply, the gas urges the conduit walls into a first condition in which the walls define a respective conduit passage along which the gas travels from the respective first end to the respective second end and wherein each conduit is compressibly deformable into a second condition in which the passage is substantially collapsed. The method includes mapping the shape of the particular patient's head, and forming the headgear into a headgear shape in accordance with the mapping such that the headgear, when fitted to the particular patient's head, is a close fit thereon.

In an embodiment, the method may include after mapping the shape of the particular patient's head, forming a head template in accordance with the mapping. Also, the forming the headgear into a headgear shape may include forming the headgear in accordance with the shape of the template.

In another embodiment, the mapping the shape of the particular patient's head may be carried out manually, while in another embodiment, the mapping the shape of the particular patient's head may be carried out by mapping means which are at least partially automated.

When the mapping the shape of the particular patient's head is carried out by mapping means which are at least partially automated, the mapping means may include a computer.

When the mapping the shape of the particular patient's head is carried out by mapping means which are at least partially automated, the mapping the shape of the patient's head may include touchless sensing of the shape of the patient's head. The touchless sensing may involve the use of a camera or a laser sensor.

In an embodiment, the headgear may be a type of headgear having at least two pieces of sheet material which are joined together, wherein the forming the headgear into a headgear shape in accordance with the mapping includes forming each of the pieces into a respective sheet shape configured to enable the achievement of the headgear shape when the headgear is formed, and joining the pieces of sheet material together in the forming of the headgear.

In another embodiment, the joining the pieces of sheet material together in the forming of the headgear includes joining the pieces of sheet material along predetermined joint paths to define detachment areas adjacent the joint paths in which the pieces of sheet material are detached from each other.

The joint paths may constitute lines of fold lines to facilitate curving of the joined pieces of sheet material in the forming of the headgear into the headgear shape.

6

Each joint path may be of a zig-zag configuration, and may be substantially sinusoidal so as to define peaks and troughs.

In this case, adjacent pairs of the joint paths may be positioned relative to each other so that each peak of one joint path of the pair is aligned with a respective trough of the other joint path and vice versa, whereby the detachment areas may be substantially diamond-shaped.

Other aspects, features, and advantages of this invention will become apparent from the following detailed description when taken in conjunction with the accompanying drawings, which are a part of this disclosure and which illustrate, by way of example, principles of the invention.

BRIEF DESCRIPTION OF THE DRAWINGS

The accompanying drawings facilitate an understanding of the various embodiments of this invention. In such drawings:

FIG. 1 is a perspective view of a headgear according to an embodiment of the invention, the headgear in a position of use;

FIG. 2 is a plan view of the headgear of FIG. 1 shown in a flattened-out condition (i.e., not in a position of use);

FIG. 3 is a perspective view of another embodiment of the headgear viewed from another angle to that shown in FIG. 1;

FIG. 4 is a perspective view, shown partly in cross-section, of a nose piece according to an embodiment of the invention;

FIG. 5 is schematic plan view of a nose piece according to another embodiment of the invention;

FIG. 6 is a schematic elevation of a conduit according to an embodiment of the invention, the conduit shown attached to an air supply;

FIG. 7 is a schematic perspective view of a cushion indicative of a manner of forming a headgear according to an embodiment of the invention;

FIG. 8 is a schematic elevation of the cushion of FIG. 7 in a formed condition;

FIG. 9 is a one way inflation nipple;

FIG. 9A is cross section through a portion of the nipple of FIG. 9;

FIG. 10 is a perspective view of a tube structure for connecting a headgear to an air supply pipe;

FIG. 11 is a plan view of headgear similar to that of FIGS. 1 and 2, showing a strap system included with the headgear; and

FIG. 12 is a plan view of headgear similar to that of FIGS. 1 and 2, showing a collapsible cuff included on the ends of the conduits of the headgear.

DETAILED DESCRIPTION OF ILLUSTRATED EMBODIMENTS

Referring to FIGS. 1 and 2, there is shown a patient interface including a headgear 10 according to an embodiment of the invention. The headgear 10 includes a pair of conduits or side portions 12 which are joined integrally to each other by a central portion 14 via joints. A head attachment means in the form of a strap 16 is also joined integrally to the side portions 12 as shown in FIG. 1, so that the side portions 12, central portion 14, and strap 16 are all of an integral, unitary construction.

The side portions 12, central portion 14 and strap 16 are formed by joining together, e.g., by high-frequency (HF) plastics welding, a pair of polymeric (e.g., plastic) sheets 17.

The manner in which the sheets 17 are joined together is such that the middle portions of the sheets 17 can be parted from each other to define passages running along the length of the side portions 12, as described in more detail below. It will be appreciated that, when the sheets 17 are configured to form such passages in the side portions 12, the side portions 12 constitute conduits, and will be referred to as such below. The sheets 17 may be joined together in any suitable manner to form such passages in the side portions 12.

The conduits 12, at the positions where the sheets 17 are joined together (e.g., by plastics welding), may be provided with inwardly extending pleats (e.g., V-shaped recesses extending inwardly with respect to the conduits) to facilitate the parting of the middle portions of the sheets 17 and hence the formation of the passages, as referred to above.

The central portion 14 has an aperture 18 at the center thereof. The headgear 10 includes a T-connection or T-shaped connector 20 which extends into the aperture 18. The T-connection 20 includes a pair of side pipes 22 and a central pipe 24 which opens into the side pipes 22. The side pipes 22 extend, in opposite directions, between the plastic sheets 17, with the center pipe 24 protruding from the central portion 14 via the aperture 18. The side pipes 22 are firmly engaged with the plastic sheets 17 so as to form a substantially air-tight seal with the sheets 17, while permitting some rotational movement along the joints between the side pipes 22 and the sheets 17.

The positions of the ends 26 of the side pipes 22 (indicated in broken lines in FIGS. 1 and 2) also serve to mark the transition from the central portion 14 to the respective side portions 12. Accordingly, the positions of the conduits 12 corresponding to the ends 26 of the side pipes 22 constitute first upper ends 28 of the conduits 12.

An attachment formation or swivel 30 which has a cylindrical union 32 at its end, is mounted around the center pipe 24 so as to be rotatable relative to the center pipe 24. As discussed further below, the attachment formation 30 is for receiving the end (not shown) of an air supply pipe leading from a flow generator or an air supply means (also not shown) for supplying air under pressure to the headgear 10, so as to connect the air supply pipe in fluid-flow communication with the center pipe 24 while permitting rotation of the air supply pipe.

In FIGS. 1 and 3, the headgear 10 is shown mounted on a patient's head 34. As illustrated, the central portion 14 and T-connection 20 of the headgear 10 are configured to extend across the patient's head 34 at a position somewhat anterior of the apex 36 of the head 34, while the strap 16 is configured to extend around the portion of the head 34 posterior of the apex 36. The headgear 10 is designed to conform to the curvature of the occiput of the patient's head 34 so that the headgear 10 is stably seated thereon.

Also, as can be seen in FIGS. 1 and 3, the conduits 12 extend downwards on opposite sides of the patient's head 34 between the eye and ear 38 of the patient on each side of the head 34. The conduits 12 curve forwards towards their lower extremities, to terminate at second ends 40 (see FIG. 1) that are opposite to the first ends 28. The second ends 40 are adjacent to the patient's nose 42 and may be attached to a nasal interface or seal forming portion, such as the nose piece 150 referred to below (see FIG. 3) which is in contact with the patient's nose.

As shown in FIG. 1, attached to the second end 40 of each conduit 12 is a nose attachment formation or nasal/seal interface connector 44, having a part which extends via the respective second end 40, between the plastic sheets 17, to

a position (not shown) within the conduit 12, and another portion 46 which is outside the conduit 12.

Each portion 46 of the nose attachment formation 44 is configured as a socket for receiving complementary formations which are connected to nose piece 150 as discussed below. The headgear may be provided with a pair of seal rings 46.1, each joined to the headgear at a respective aperture for establishing a close seal with the nose-piece 150.

In the illustrated embodiment, the sheets 17 are flocked (e.g., have a velvet-like texture) to provide comfort to the patient, and their attachment to each other is reinforced by stitching 52 (see FIG. 1). The headgear 10 may also be provided with a cover (not shown) of cloth or other material which will be comfortable to a patient, and the cover may have decorative effects, e.g., patterns or other markings, which may be attractive to a child patient.

A thin layer of foam rubber or other suitable padding (not shown) may be provided in selected locations between the inner surfaces of the sheets 17 to enhance the structural integrity of the headgear 10, or otherwise improve comfort to the patient especially on the bony regions of the face, e.g., the cheekbones.

Referring now to FIG. 4, the nose piece 150 is discussed in more detail. The nose piece 150 includes a conduit 152 having outer walls 154. The outer walls 154, in turn, are double walls, having inner wall portions 156 and outer wall portions 158. The inner wall portions 156 and outer wall portions 158 are sealingly joined to each other at first and second ends 160 and 162, respectively, of the nose piece 150. Each end 160 and 162 is configured for connection in fluid flow communication to the portion 46 of a respective nose attachment formation 44.

The inner wall portions 156 and outer wall portions 158 define, between them, an annular space 164 extending circumferentially with respect to the nose piece 150.

The conduit 152 defines a pair of apertures 166 each for accommodating a respective nostril formation 168 of flexible plastic or elastomer (e.g., silicone rubber) which extends through the relevant aperture 166. Each nostril formation 168 has a central passage 170. The nostril formations 168 are shaped to provide a close comfortable fit in the patient's nose 42, i.e., in the patient's nostrils. The nostril formations 168 may have any suitable form, e.g., nasal pillows, nasal prongs, cannula, or nasal puffs. If desired, the nostril formations 168 may be shaped and sized so as to be customized to a particular patient's nose.

The outer walls 154 of the nose piece 150 define a central passage 172 for establishing fluid flow communication between the interiors of the conduits 12 and passages 170 of the nostril formations 168, and hence with the patient's nose 42.

Similar to the headgear 10, the conduit 152 may be formed from sheets of polymeric (e.g., plastic) material which may be suitably joined by HF plastics welding to achieve the construction represented in FIG. 4.

Opening through the outer wall portion 158 of each nose piece 150, into the respective annular space 164, is an inflation nipple 175 having a one-way valve 174 which is illustrated in more detail in FIGS. 9 and 9A. The nipple 175 and one-way valve 174 permit the introduction of air into the annular space 164 so as to inflate the conduit 152 to provide it with sufficient rigidity to maintain its shape, while not depriving it of sufficient flexibility so as to be uncomfortable to the patient. The nipple 175 and valve 174 can thus be used to introduce more air into, or to remove air from, the annular

space **164** so as to allow the rigidity or size of the conduit **152** to be adjusted to suit a particular patient or particular circumstances.

The nipple **175** may include a short tube **302**. The nipple **175** includes a base **304** below the short tube **302**, the base being joined, e.g., by plastics welding, to the nose piece **150** (or to the headgear **10** in the case of the headgear **10** being inflatable). The plastic material of the base **304** may be thinner than that of the remainder of the tube structure **300**. This allows for twisting of the short tube **302** as represented in phantom lines, and by the arrow **305**, in FIG. 9. The base **304** also is near the one way valve **174** as described below.

The nipple **175** also includes a cap **306** receivable as a tight but removable fit in the short tube **302** for closing off the short tube **302** and preventing the passage of air through it. As illustrated, a flexible cord **308** joins the cap **306** to an upper side position of the short tube **302**. The flexibility of the cord **308** allows the cap **306** to be moved between its closure condition as shown in which it closes the short tube **302**, and an open condition in which it is removed from the opening of the short tube **302**.

The nipple **175** is also provided with an upper waist region **310** and a lower waist region **312** which is narrower than the upper waist region **310**. These waist regions allow deformation of the nipple **175** by permitting the lower waist region **312** to be telescopically received within the upper waist region **310**. This, in turn, allows the nipple **175** to be pressed into that portion of the nose piece **150** (or headgear **10** if the headgear **10** is inflatable) to which it is joined so that it becomes inverted within that portion, and effectively stowed away.

As described above, the base **304** of the nipple **175** is near the one way valve **174**, which has a moveable flap **174.1**. The moveable flap **174.1** extends from and is hinged to, and formed integrally with, the internal wall of short tube **302**. The one way valve **174** includes a flange **174.4** which serves the purposes of a detent to prevent the flap **174.1** moving past the flange **174.4** in the direction of arrow **174.2**, when the cavity **174.5** is under pressure. The flange **174.4** also provides a location for the edge of the flap **174.1** to seal against.

When the cavity **174.6** has a greater pressure therein than the cavity **174.5**, e.g., when it is being inflated, the flap **174.1** will move in the direction of arrow **174.3** allowing inflation. As soon as there is a pressure differential, the flap **174.1** will move to a closed position, thereby acting as a one way valve. To deflate via the nipple **175**, the user need only deform nipple **175** by compressing or squeezing the sides in the region of the one way valve **174**, whereby the deformation will break the seal with the flange **174.4** allowing deflation.

In another embodiment, the nostril formations **168**, instead of being separate formations of rigid plastic, may be integral with the conduit **152**. In such an embodiment, the apertures **166** may be omitted.

In one form of this embodiment, the nostril formations **168** may have outer wall portions and inner wall portions which may be continuous with the outer wall portions **158** and inner wall portions **156**, respectively, of the conduit **152**, and which define between them a space which may be continuous with the annular space **164**. Thus, inflation of the conduit **152** may also cause inflation of the nostril formations **168**.

In a further embodiment as shown in FIG. 3, the nose piece **150** may be integral with the conduits **12** so that the headgear **10** and conduit **152** are of a unitary construction. In one form of this embodiment, the nostril formations **168** may be rigid plastics formations received in apertures **166** of

the conduit **152**. In another form of this embodiment, the nostril formations **168** may be integral and continuous with the conduit **152** as described above.

In another embodiment as shown in FIG. 5, instead of having a nose piece which includes a conduit such as the conduit **152** and nostril formations such as the nostril formations **168**, two inflatable curved nostril formations **176** (only one being shown) may be provided. In the illustrated embodiment, each nostril formation **176** has outer wall portions **178** and inner wall portions **180** defining a central enclosed annular space **182** between them, a one-way valve **184** for introducing air to the space **182** to inflate the nostril formation **176**, and a central passage **186**. In this embodiment, one end **188** of each nostril formation **176** is configured for attachment to the portion **46** of a respective nose attachment formation **44**, while an opposite end **190** is configured for being received in the patient's nose **42**. In an embodiment, the nostril formations **176** for each of the patient's two nostrils may be adapted to be attached to each other, to facilitate support of the nostril formations **176** and their sealing with the patient's nose.

In other embodiments, the nose pieces **150** or conduits **152** thereof may be other than the inflatable constructions as described above. They may, instead, have single outer walls of similar construction to the conduits **12**.

For example, the nasal interface may be structured similar to nasal assemblies disclosed in U.S. patent Ser. No. 10/781, 929, which is incorporated herein by reference in its entirety.

Alternatively, the conduits **12**, instead of having their walls formed of single plastic sheets as described above, may be made up of double walls having inner wall portions and outer wall portions similar to the inner wall portions **156** and outer wall portions **158**, respectively, of the nose piece **150**. These inner and outer wall portions would define a sealed and inflatable inner space similar to the space **164** of the nose pieces **150**.

This construction of double walls may be used for the whole of the headgear **10**, or selected portions of it. This would enable selected portions of the headgear **10**, which are inflatable as a result of the double wall construction, to be inflatable as in the case of the conduits **152** of the nose piece **150**, to achieve a desired amount of rigidity where required. The double wall construction would also serve to reduce noise transferred through the walls.

In one embodiment, an inner skeleton may be provided in some or all parts of the above equipment where such double walls are provided in the cavity between the relevant inner and outer wall portions. The inner skeleton may be comprised, for example, of spring wire, and this could be configured in an expanded condition to provide further structural support where the skeleton is used.

In use, as described in relation to FIG. 1, the headgear **10** is placed on the head **34** of the patient. The T-connection **20** is connected to a supply pipe (not shown) of an air supply (also not shown) configured for supplying air under a positive pressure. The supply pipe will include an end for attachment to the attachment formation **30** for effecting a seal with the T-connection **20**.

In another embodiment or in combination with the embodiment described above, a suitable structure may be provided for minimizing the extent to which the supply pipe pulls on the headgear **10**. This structure may involve a pivotable pipe connection, a ball-and-socket connection, or a flexible bellows connection (such as that described in the next paragraph) to the T-connection **20**, or to another part **290** (FIG. 12) of the relevant headgear in an embodiment where there is no such T-connection. This may facilitate

stability of the headgear **10** by reducing the extent to which drag forces on the supply pipe are transferred to the headgear **10**.

The attachment formation **30** may include a concertina tube **300** as illustrated in FIG. **10**, which terminates in a cylindrical union **32**. The tube **300** may allow for relative rotation of the air supply coupling thereby preventing the transfer of bending forces which would otherwise uncouple the air supply connection.

The supplied air passes into the central pipe **24** of the T-connection **20** and then via the side pipes **22** into the conduits **12**. As the air is under a positive pressure, it serves to inflate the conduits **12** so that they define central passages extending from their respective first ends **28** to their respective second ends **40**. The air then passes via the nose attachment formations **44** and nose piece **150**, into the patient's nose **42** (i.e., the nostrils).

The headgear **10** may be custom fit to a particular patient's head **34**. This may be achieved by scanning or mapping the head **34** to determine its shape in a three-dimensional sense, and then cutting the sheets **17** so that when the sheets **17** are joined to each other they form a headgear **10** which is suitable for achieving a close and comfortable fit on the patient's head **34**. It will be appreciated that there may be as many different shapes of the headgear **10** as there are patient's heads **34**. In addition, once a particular shape is determined in which to form a sheet **17** in relation to a particular patient's head, or in relation to a particular type of head shape (which may apply to more than one patient), there is no limitation on the number of sheets that may be cut to a particular sheet shape to form a particular headgear.

In an embodiment, the sheets **17** may be joined along predetermined joint paths. In this regard, reference is made to the cushion **200** shown in FIGS. **7** and **8**, which has two sheets **202** (only one being shown) joined along paths **204**. It will be seen that the paths **204** are of a sinusoidal, zig-zag shape with peaks **206** and troughs **208** such as may be found in quilting-like formations. The troughs **208** of each path **204** are aligned with the peaks **206** of the next path and vice versa, so as to form substantially diamond-shaped areas **210** between the paths where the sheets **202** are not connected to each other. In an embodiment of the headgear **10** under discussion, the headgear **10** may be formed with the sheets **17** being joined to each other in a similar fashion to the sheets **202**, with the paths serving as fold lines to facilitate curving of the joined sheets **17** (as represented by the curving of the cushion **200** in FIG. **8**) to conform to the shape of the head **34**.

The regions of the headgear **10** corresponding to the diamond-shaped areas **210** of the cushion **200** may be inflated to form a number of juxtaposed cushioned zones to provide added comfort to the patient and to facilitate the firm and even seating of the headgear **10** on the patient's head **34**.

Alternatively, instead of using the mapping to determine the shape in which the sheets **17** are to be cut as described above, the mapping may be used to form part of a headgear by forming a thermoplastic polymer in the shape of the patient's head **34**.

The shaping of the headgear **10** to suit the particular shape of a patient's head **34** may significantly assist in achieving a headgear **10** having conduits **12**, a central portion **14**, and a strap **16** which are snugly fitted to the patient's head **34**. This may achieve an effective distribution of pressure between the headgear **10** and the patient's head **34** rather than having specific locations at which there are high pressure points and other locations at which there is insuf-

ficient pressure. This, in turn, facilitates the secure attachment of the headgear **10** to the patient's head **34**.

In addition, the unitary construction of the conduit **12**, central portion **14** and strap **16**, with the headgear **10** being specifically suited to a particular patient's head **34**, eliminates the need for adjustment parts of the headgear **10** which would otherwise be required to fasten the headgear **10** securely to the patient's head **34**. This unitary construction also simplifies the donning of the headgear **10** and removal thereof from the patient's head.

The snug securing of the headgear **10** to the patient's head **34** may be further facilitated in those embodiments of the headgear **10** having double walls, or portions with double walls as referred to above. In these embodiments, inflation of the double walls (i.e., provision of inflating air into the space between the double walls) causes the respective inner wall portions to press more firmly against the patient's head **34**. This can be particularly useful in relation to those parts of the patient's head **34** which are of a substantially concave or recessed shape, such as immediately in front of the patient's ears **38**.

With the nose piece **150** being joined to the conduits **12** as described above, the air supplied into the center pipe **24** of the T-connection **20**, after having passed through the passages of the conduits **12**, proceeds to pass along the passage **166** of the conduit **152** of the nose piece **150**, and into the patient's nose **42**.

Exhalation by the patient is facilitated by using a material for the plastic sheets **17** which is to some extent gas permeable, preferably in the vicinity of the nose **42** of the patient. This will allow for a certain amount of leakage or venting of air and exhaled carbon dioxide therethrough. A suitable thermoplastic elastomer, e.g., a poly-olefin, may be used for this purpose. Alternatively, the sheets **17**, instead of being fully of plastic, may be wholly, or may have parts, made of other types of gas permeable material, e.g., silk or other woven material, or the Polytetrafluoroethylene (PTFE) material known as GORETEX®.

As the patient breathes out, the exhaled breath can then pass via the nose pieces **150** and then through the walls of the conduits **12** at positions close to the respective second ends **40** thereof.

A particularly suitable material for the sheets may be breathable polyurethane which allows the passage of water vapour with the escaping air, but provides a substantially airtight passage. By the expression "substantially airtight," it is meant that sufficient resistance to the passage of air therethrough is provided to prevent too much air from escaping. The ability to allow water vapour to pass through is advantageous as it may assist in avoiding an undesirable accumulation of moisture originating from gases exhaled by the patient, in the interior passages of the conduits **12**. Materials that may provide these properties include those manufactured by the Darlington Corporation known by the trademark DARLEX®[®], or the 3M product known by the trademark THINSULATE®[®], or the Polytetrafluoroethylene (PTFE) material known as GORETEX®[®], or the product known as ATLANTECH™[™] made by Atlantis Weather Gear Inc.

With the walls of the conduits **12**, or parts thereof, being gas permeable as described above, some of the air supplied via the center pipe **24** of the T-connection **20** will also escape from the conduits **12**. This arrangement and the flexible nature of the passageways can assist in a reduction in the noise generated by the passage of air via the conduit **12** to the nose pieces **150**.

13

The passage of exhaled gas through the walls of the conduits **12** may also provide a useful means for allowing heat to escape from the headgear **10**. Such heat, if not allowed to escape in this manner, may result in the headgear **10** becoming so heated as to be unnecessarily uncomfortable for the patient. In addition, the gas permeability of the materials used, as referred to above, may permit the passage of heat and water vapour through the parts of the headgear on top of the patient's head **34** to improve comfort, especially in warmer weather. The construction of the headgear **10**, and particularly its unitary nature, has the advantage that, if the headgear **10** is being worn by the patient, and the patient rolls his or her head **34** onto a surface such as a pillow so that one of the conduits **12** is flattened by the pressure of the patient's head **34** on the pillow, all or most of the air that would have passed through that conduit **12** but which is prevented from doing so due to the constriction of the conduit's passage is permitted to pass instead through the other conduit **12**. This is enabled due to the flexibility of the conduits **12** and their resultant ability to expand and substantially collapse. Thus, the total volume flow rate of the air through the pair of conduits remains substantially constant during the flattening and expansion of the respective conduits. Depending on the configuration and cross-sectional shapes of the conduits **12** when the above flattening and expansion occurs, the collapsing of the conduit **12** causes a change in the ratio between a height extent and a lateral extent of that conduit, with the height extent decreasing and the lateral extent increasing. Similarly, the deformation of the other conduit causes a change in the ratio between its height extent and lateral extent with the height extent increasing and the lateral extent decreasing.

In an embodiment, the headgear may include an adjustable head cap with the conduits being attached to the cap at opposite sides thereof. In this case, the cap may constitute the attachment means, and the connection means may be mounted on the cap.

In another embodiment, the conduits may be detachable from the attachment means so that the attachment means may be selectively releasably connected with differently sized and/or shaped conduits. In this case, the conduits may be selectively releasably connected with differently sized and/or shaped attachment means, whereby the headgear may form part of a modular headgear system having interchangeable attachment means and conduits.

In yet another embodiment, the headgear may be adapted for use with a patient mask, the mask being configured to fit the patient's head adjacent the patient's nose to direct gas from the conduits to the nose. Then, the headgear may be adapted to be detachable from the mask to enable the patient to selectively remove the mask from the headgear and hence from the patient's head while the headgear continues to be being worn by the patient.

A particular advantage of the headgear **10** as described is that, when not in use, the T-connection **20** may be removed from the aperture **18**. Then, the conduit **12**, the central portion **14**, and the strap **16** may be flattened out so as to collapse the passages of the conduits **12**, and rolled up or folded for storage purposes, so that a minimum of storage room is required. On the other hand, when in use, the passage of air itself through the conduits **12** serves to inflate the passages and to press the inside walls of the conduits **12** firmly against the sides of the patient's head **34** to achieve a comfortable and snug fit.

The headgear **10** has various advantages. For example, an advantage of the headgear **10** is that the T-connection **20** is located in use at a position of the patient's head which is

14

unlikely to be subjected to any compression force due, for example, to the patient's head being on a pillow. Thus, while the conduits **12** are flexible and should therefore not provide much discomfort to the patient even if the patient lies on them, this should not be an issue in respect of the relatively hard T-connection **20**, due to the location of this component.

In addition, the relative flexibility and hence softness of the material from which the conduits **12**, the central portion **14** and strap **16** are formed allows the headgear **10** to be engaged with parts of the patient's head, such as the patient's cheeks, that may have been too sensitive for engagement with prior art devices.

The fact that the conduits **12** and central portion **14** define most of the passageways through which air needs to travel to be delivered to the patient means that the need for additional tubing and tubing securement straps may be avoided. Therefore, this also avoids the bulk and weight that such additional tubing and securement straps might involve.

The ability of one of the conduits **12** to expand to allow for a greater volume flow rate when the other conduit **12** is compressed or collapsed so as to be generally flat against the patient's face (e.g., when the patient lies on the other conduit **12** on a pillow) enhances the patient's comfort and minimizes discomfort that might have been caused if more inflexible tubing were used. It also reduces discomfort that may be caused by engagement of the headgear **10** with contact pressure points on the patient's head **34**.

The use of plastics welding as described above for manufacturing the headgear **10** avoids the need for clips, buckles, adjustment straps and the like, thus providing for greater simplicity of use. In addition, the forming of the headgear **10** to suit the shape of the patient's head **34** and the inherent lightweight nature of the headgear **10** assists in providing greater comfort to the patient.

Referring to FIG. 6, there is shown a schematic representation of a PAP machine conduit **400** according to an embodiment of the invention. The conduit **400** has flexible conduit walls **402**, and has a first end **404** and a second end **406**. The first end **404** is attached to a supply means **408** for supplying air under a positive pressure. As in the case of the conduits **12** described above, the conduit **400** is collapsible. As air under a positive pressure is supplied by the supply means **408**, the pressure of the air urges the walls **402** into the condition shown, in which the walls **402** define a central passage **410** of the conduit **400**. Thus, the air may pass along the passage **410** to the second end **406**, where the air may be directed as required.

As an alternative to the walls **402** being urged into the condition shown only by the pressure of the air, a collapsible spring may be provided which assists in preventing kinking of the conduit **400** in use.

The flexibility of the walls **402** allows the conduit **400** to be folded or rolled to a compact size during storage or travel. In addition, these walls may be of a single wall type or a double wall type similar to the walls **154** described above. Such a double wall construction may also provide enhanced insulation to assist in regulating the temperature of the air from the air supply means **408**.

Illustrated in FIG. 11 is headgear **1010**, which is similar to the headgear **10** of FIGS. 1 and 2, and accordingly, like parts have been like numbered. The headgear **1010** differs from the headgear **10** in that two straps **1012** are provided, each of which is connected to and extends from a respective one of the conduits or side portions **12** of the headgear **10**. The straps **1012** respectively terminate in buckle members **1014** and **1016** which can connect to a mask or nose piece

15

and allow a user to secure the headgear **1010** to his or her head. The straps **1012** may provide for adjustability of the strap length.

Illustrated in FIG. **12** is headgear **1110**, which is similar to the headgear **10** of FIGS. **1** and **2**, and accordingly, like parts have been like numbered. The headgear **1110** differs from the headgear **10** in that a collapsible cuff **1112** is provided on ends of each of the conduits or side portions **12**. As illustrated, the collapsible cuff **1112** is of a bellows formation. The collapsible cuff **1112** allows the length of the ends of the conduits **12** to be adjusted by extension or contraction, as required.

It will be understood that the invention disclosed and defined herein extends to all alternative combinations of two or more of the individual features mentioned or evident from the text. All of these different combinations constitute various alternative aspects of the invention.

While the invention has been described in connection with what are presently considered to be the most practical and preferred embodiments, it is to be understood that the invention is not to be limited to the disclosed embodiments, but on the contrary, is intended to cover various modifications and equivalent arrangements included within the spirit and scope of the invention. In addition, while the invention has particular application to patients who suffer from OSA, it is to be appreciated that patients who suffer from other illnesses (e.g., congestive heart failure, diabetes, morbid obesity, stroke, bariatric surgery, etc.) can derive benefit from the above teachings. Moreover, the above teachings have applicability with patients and non-patients alike.

What is claimed is:

1. A patient interface for delivering breathable gas under positive pressure to a patient for treatment of sleep disordered breathing, the patient interface comprising:

an air connector configured to deliver a supply of breathable gas, the air connector being adapted to be positioned on top of the patient's head when the patient interface is worn;

a seal forming portion configured to direct the breathable gas to the patient's airway;

a pair of flexible side portions of elastic material and configured to support the seal forming portion in a desired position on the patient's face, each said flexible side portion configured to deliver at least a portion of the breathable gas to the seal forming portion in use, each said flexible side portion providing a conduit having a top portion in fluid communication with the air connector and a bottom portion detachably connected to, and in fluid communication with, a lateral side of the seal forming portion, each said conduit being arranged to, in use, extend along and engage a respective side of the patient's head between the patient's eye and ear;

a socket joint that removably connects the bottom portion of each said conduit to the seal forming portion to provide the breathable gas to the seal forming portion, each said socket joint including 1) a socket portion having a socket aperture, a seal ring, and a seal interface connector at least partly inserted within the bottom portion, and 2) a complementary formation that is removably received through the socket aperture and engages with the seal interface connector and the seal ring, wherein each said seal ring sealingly engages with the complementary formation of the seal forming portion when the complementary formation is inserted into the socket portion;

16

a rear securement strap including a portion that extends from one of the side portions to the other one of the side portions and is adapted to engage the back of the patient's head and stably secure the patient interface when worn, wherein the patient interface does not include additional conduit tubing and does not include an additional securement strap; and

a central portion integrally formed with the pair of side portions to join the top portions of the conduits, the central portion and the conduits forming a unitary, one-piece construction constructed of a same material, the central portion having an inner wall portion with an inner surface adapted in use to contact the top of the patient's head and an outer wall portion with an outer surface positioned opposite the inner surface, the outer surface of the outer wall portion having an aperture positioned in a plane parallel to the inner surface of the inner wall portion, wherein the entire length of the inner surface of the central portion is configured to engage the top of the patient's head in use to stably position and hold the air connector at the top of the patient's head;

wherein the conduits, the central portion and the seal forming portion form a ring with a ring-shaped gas flow path,

wherein the air connector is removably attached to the central portion, the air connector being relatively rigid compared to the central portion, the air connector including an exterior part that protrudes from within the aperture and an interior part that is received within the aperture and positioned within the ring-shaped gas flow path between the inner and outer wall portions so that pressurized gas in use is delivered between the inner and outer walls of the central portion and into the side portions,

wherein at least a portion of the air connector is pivotably connected to the central portion, and

wherein the patient interface further comprises a swivel coupling device rotatably mounted to the exterior part of the air connector, the swivel coupling device being adapted to connect to an air supply tube adapted to deliver the supply of breathable gas to the air connector.

2. The patient interface of claim **1**, wherein the swivel coupling device has a coaxial arrangement with the air connector.

3. The patient interface of claim **1**, wherein the central portion is arranged such that the air connector is adapted to be positioned anterior of an apex of the patient's head when the patient interface is worn.

4. The patient interface of claim **1**, wherein the pair of side portions is shaped to match a contour of the patient's head.

5. The patient interface of claim **1**, further comprising a vent adapted to be positioned in the vicinity of the patient's nose, in use, to allow exhaled carbon dioxide to pass to atmosphere.

6. The patient interface of claim **1**, wherein each conduit comprises a conduit wall that is deformable between (a) an open condition in which the conduit wall defines a conduit passage along which the breathable gas can travel from the top portion to the bottom portion, and (b) a collapsed condition in which the conduit wall substantially collapses the conduit passage.

7. The patient interface of claim **6**, wherein each conduit is configured to collapse into the collapsed condition under the weight of the patient's head.

8. The patient interface of claim **6**, wherein each conduit is configured to accommodate an increase in volume flow

17

rate of breathable gas through the conduit when the conduit passage of the other conduit is in the collapsed condition.

9. The patient interface of claim 8, wherein the conduits are configured such that a total volume flow rate of breathable gas through the conduits remains substantially constant even if one of the conduits is deformed into the collapsed condition.

10. The patient interface of claim 1, wherein the strap is joined to the conduits.

11. The patient interface of claim 1, wherein the strap is formed integrally with the conduits.

12. The patient interface of claim 1, wherein the strap comprises laminated fabric and foam

wherein the swivel coupling device has a coaxial arrangement with the air connector, and

wherein the central portion is arranged such that the air connector is adapted to be positioned anterior of an apex of the patient's head when the patient interface is worn.

13. The patient interface of claim 1, wherein:

the central portion is arranged such that the air connector is adapted to be positioned anterior of an apex of the patient's head when the patient interface is worn,

each conduit comprises a conduit wall that is deformable between (a) an open condition in which the conduit wall defines a conduit passage along which the breathable gas can travel from the top portion to the bottom portion, and (b) a collapsed condition in which the conduit wall substantially collapses the conduit passage,

each conduit is configured to accommodate an increase in volume flow rate of breathable gas through the conduit when the conduit passage of the other conduit is in the collapsed condition, and

each conduit is configured to deform into the collapsed condition under the weight of the patient's head.

14. The patient interface of claim 1, wherein the at least the portion of the air connector is configured to rotate about a first axis and the swivel coupling is configured to rotate about a second axis, the first axis being perpendicular to the second axis.

15. The patient interface of claim 1, wherein the headgear further comprises a first joint between the central portion and a first one of the top portions and a second joint between the central portion and a second one of the top portions, the first and second joints being spaced from one another on opposite lateral sides of the central portion, the interior part of the air connector being positioned between the first and second joints.

16. The patient interface of claim 1, wherein the seal forming portion comprises nasal pillows.

17. The patient interface of claim 1, wherein the seal forming portion comprises a nasal cushion.

18. The patient interface of claim 1, wherein the seal forming portion comprises a mask at least part of which is configured to engage under the patient's nose.

19. The patient interface of claim 1, wherein the seal forming portion is supported solely by the seal interface connectors to form a two-point headgear support system, and the headgear support system does not include straps that connect to and support the patient interface.

20. A patient interface for delivering breathable gas under positive pressure to a patient for treatment of sleep disordered breathing, the patient interface comprising:

headgear having a pair of flexible side portions and a central portion having a top aperture, the top aperture being configured to be in communication with an air

18

supply tube adapted to deliver a supply of breathable gas, the top aperture being adapted to be positioned on top of the patient's head when the patient interface is worn;

a seal forming portion configured to direct the breathable gas to the patient's airway;

the pair of flexible side portions being configured to support the seal forming portion in a desired position on the patient's face and to deliver the breathable gas to the seal forming portion in use, each said side portion having a conduit with a top portion in fluid communication with the top aperture and a bottom portion detachably connected to, and in fluid communication with, a lateral side of the seal forming portion, each said conduit being arranged to, in use, extend along and engage a respective side of the patient's head between the patient's eye and ear, wherein the pair of conduits, the central portion and the seal forming portion form a hollow ring with a ring-shaped gas flow path; and

a socket joint that removably connects the bottom portion of each said conduit to the seal forming portion to provide the breathable gas to the seal forming portion, each said socket joint including 1) a socket portion having a socket aperture, a seal ring, and a seal interface connector at least partly inserted within the bottom portion, and 2) a complementary formation that is removably received through the socket aperture and engages with the seal interface connector and the seal ring, wherein each said seal ring sealingly engages with the complementary formation of the seal forming portion when the complementary formation is inserted into the socket portion,

wherein the socket portion is formed on a bottom end of each bottom portion and the complimentary formation is formed as an extension of the seal forming portion, wherein each said seal interface connector has 1) a first end extending into the bottom end to a position within the respective conduit, and 2) a second end that removably receives therein the complimentary formation,

wherein the seal ring is joined to the conduit, is positioned at the socket aperture, and extends in a radially inward direction from a circumferential wall of the socket portion;

wherein the central portion is integrally formed with the pair of side portions to join the top portions of the conduits, the central portion and the conduits forming a unitary, one-piece construction of the same material, the central portion having an inner wall portion with an inner surface adapted in use to contact the top of the patient's head and an outer wall portion with an outer surface positioned opposite the inner surface, the outer surface of the outer wall portion having the top aperture,

wherein the headgear further comprises a first joint between the central portion and a first one of the top portions and a second joint between the central portion and a second one of the top portions, the first and second joints being spaced from one another on opposite lateral sides of the central portion,

wherein the patient interface further includes an air connector removably attached to the headgear at the central portion, the air connector being relatively rigid compared to the flexible side portions, the air connector having an interior portion being received within the top aperture between the inner and outer wall portions and between the first and second joints so that pressurized gas in use is delivered between the inner and outer

19

walls of the central portion and into the side portions, said air connector further comprising an exterior portion protruding from the top aperture, the interior portion of the air connector being positioned within the ring-shaped gas flow path between the first and second joints and the exterior portion being positioned outside of the ring-shaped gas flow path,

wherein the entire length of the central portion between the first and second joints is configured to continuously engage the patient's head along the top of the patient's head to hold the air connector in a stable position at the top of the patient's head,

wherein the air connector includes a swivel coupling configured to be pivotably connected to the supply tube,

wherein the headgear further comprises a rear strap connected to each said conduit at a rear strap joint positioned superior to the patient's ear, each said rear strap extending rearwardly from the rear strap joint to engage the occiput of the patient's head at a position superior to the patient's ear, and

wherein the headgear includes at least a first flexible bellows configured to reduce the extent to which drag forces from the supply tube are transferred from the air connector to the headgear, the at least first flexible bellows being positioned proximate the central portion and superior to each said rear strap joint and being configured to engage a portion of the patient's head superior to the rear strap joint, and wherein each said conduit includes a section below the rear strap joint that does not have a bellows.

21. The patient interface of claim 20, wherein the air connector comprises a T-shaped joint having a center pipe and two lateral side pipes each pivotably connected to one of the top portions, the center pipe including the swivel coupling.

22. The patient interface of claim 20, further comprising a second flexible bellows is positioned proximate the bottom end of each said conduit, to provide length adjustment.

23. The patient interface of claim 20, wherein the central portion is configured to extend across the patient's head at a position that is anterior of the apex of the patient's head.

24. The patient interface of claim 20, wherein each said conduit has a portion configured to be positioned anterior to the patient's ear, said portion curving forward towards the bottom portion.

25. The patient interface of claim 20, wherein the air connector has an inner portion received within the aperture of the central portion that is larger than the aperture.

26. The patient interface of claim 20, further comprising a cover of cloth material.

27. The patient interface of claim 20, further comprising padding provided to an inner surface of each conduit where it is configured to contact the patient's cheekbones.

28. The patient interface of claim 20, wherein the seal forming portion comprises nasal pillows.

29. The patient interface of claim 20, wherein the seal forming portion comprises a nasal cushion.

30. The patient interface of claim 20, wherein the seal forming portion comprises a mask at least part of which is configured to engage under the patient's nose.

31. The patient interface of claim 30, further comprising a pair of length-adjustable headgear straps that connect to the mask directly via a pair of intermediate fasteners.

32. The patient interface of claim 20, wherein the seal forming portion is supported solely by the seal interface

20

connectors to form a two-point headgear support system, and the headgear does not include straps that connect to and support the patient interface.

33. The patient interface of claim 20, wherein the patient interface does not include additional tubing and does not include additional straps.

34. A patient interface for delivering breathable gas under positive pressure to a patient for treatment of sleep disordered breathing, the patient interface comprising:

a gas connector configured to deliver a supply of breathable gas, the gas connector being adapted to be stably positioned at the top of the patient's head when the patient interface is worn;

a seal forming portion configured direct the breathable gas to the patient's airway;

a pair of flexible side conduits of elastic material and configured to support the seal forming portion in a desired position on the patient's face, each said flexible side conduit configured to deliver at least a portion of the breathable gas to the seal forming portion in use, each said side conduit having a top portion in fluid communication with the gas connector and a bottom portion connected to, and in fluid communication with, a lateral side of the seal forming portion, each said side conduit being arranged to, in use, extend along and engage a respective side of the patient's head between the patient's eye and ear; and

a central portion integrally formed with the pair of side conduits to join the top portions of the side conduits, the central portion and the pair of side conduits forming a unitary one-piece construction of the same material, wherein the central portion is configured to engage the top of the patient's head in use to stably position and hold the gas connector at the top of the patient's head, the central portion having an inner wall portion to engage the top of the patient's head and an outer wall portion,

wherein the seal forming portion, the conduits and the central portion form a ring with a ring-shaped gas path, and at least a part of the gas connector that is relatively harder than the central portion is positioned within the ring-shaped gas path and between the inner and outer wall portions, and another part of the gas connector is positioned outside the ring-shaped gas path.

35. The patient interface of claim 34, further comprising a rear securement strap including a portion that extends from one of the side conduits to the other one of the side conduits and is adapted to engage the back of the patient's head and stably secure the patient interface when worn, wherein the patient interface does not include additional conduit tubing and does not include an additional securement strap, and wherein each of the side conduits includes an upper portion superior to the rear securement strap and a lower portion inferior to the rear securement strap, each said upper portion being wider than the lower portion.

36. The patient interface of claim 35, wherein the flexible side conduits include at least a first section with at least a first flexible bellows, the at least first flexible bellows being configured to at least partly reduce the extent to which drag forces from the supply tube are transferred from the gas connector to the side conduits, the at least first flexible bellows being positioned superior to a joint where the rear securement strap is joined to the conduit, the at least first flexible bellows having an inner surface that is curved to generally match the shape of the patient's head and configured to engage the patient's head.

21

37. The patient interface of claim 34, wherein at least a portion of the gas connector is movably connected to the central portion.

38. The patient interface of claim 34, wherein the patient interface further comprises a swivel coupling device rotatably mounted to the gas connector, the swivel coupling device being adapted to connect to a gas supply tube adapted to deliver the supply of breathable gas to the gas connector.

39. The patient interface of claim 34, wherein the inner wall portion comprises an inner surface adapted in use to contact the top of the patient's head and the outer wall portion comprises an outer surface positioned opposite the inner surface, the outer surface of the outer wall portion having an aperture positioned in an aperture plane parallel to the inner surface of the inner wall portion, wherein the entire length of the inner surface of the central portion is configured to engage the top of the patient's head in use.

40. The patient interface of claim 39, wherein the part of the gas connector that is relatively harder than the central portion is positioned between the aperture plane and the inner surface of the central portion, and a remainder of the gas connector is positioned outside aperture plane.

41. The patient interface of claim 34, further comprising a rear securement strap including a portion that extends from one of the side conduits to the other one of the side conduits and is adapted to engage the back of the patient's head and stably secure the patient interface when worn, wherein the patient interface does not include additional conduit tubing and does not include an additional securement strap,

wherein at least a portion of the gas connector is movably connected to the central portion,

wherein the patient interface further comprises a swivel coupling device rotatably mounted to the gas connector, the swivel coupling device being adapted to connect to a gas supply tube adapted to deliver the supply of breathable gas to the air connector,

wherein the inner wall portion comprises an inner surface adapted in use to contact the top of the patient's head and the outer wall portion comprises an outer surface positioned opposite the inner surface, the outer surface of the outer wall portion having an aperture positioned in an aperture plane parallel to the inner surface of the inner wall portion, wherein the entire length of the inner surface of the central portion is configured to engage the top of the patient's head in use, and

wherein the part of the gas connector that is relatively harder than the central portion is positioned between the aperture plane and the inner surface of the central portion, and a remainder of the gas connector is positioned outside the aperture plane.

42. The patient interface of claim 34, further comprising a socket joint that removably connects the bottom portion of each said side conduit to the seal forming portion to provide the breathable gas to the seal forming portion, each said socket joint including 1) a socket portion having a socket aperture, a seal ring, and a seal interface connector at least partly inserted within the bottom portion, and 2) a complementary formation that is removably received through the socket aperture and detachably engages with the seal interface connector and the seal ring, wherein each said seal ring sealingly engages with the complementary formation of the seal forming portion when the complementary formation is inserted into the socket portion.

43. The patient interface of claim 42, wherein the socket portion is formed on a bottom end of each bottom portion and the complimentary formation is formed as an extension of the seal forming portion,

22

wherein each said seal interface connector has 1) a first end extending into the bottom end to a position within the respective conduit, and 2) a second end that removably receives therein the complimentary formation,

wherein the seal ring is joined to the conduit, is positioned at the socket aperture, and extends in a radially inward direction from a circumferential wall of the socket portion.

44. A patient interface for delivering breathable gas under positive pressure to a patient for treatment of sleep disordered breathing, the patient interface comprising:

a seal forming portion configured to direct the breathable gas to the patient's airway;

a pair of flexible side portions of elastic material and configured to support the seal forming portion in a desired position on the patient's face, each said flexible side portion configured to deliver at least a portion of the breathable gas to the seal forming portion in use, each said flexible side portion providing a conduit having a top portion and a bottom portion detachably connected to, and in fluid communication with, a lateral side of the seal forming portion, each said conduit being arranged to, in use, extend along and engage a respective side of the patient's head between the patient's eye and ear;

a central portion connecting the top portions of the conduits, the central portion and the conduits forming a one-piece construction of the same material, the central portion having an inner wall portion to engage the top of the patient's head and an outer wall portion having an aperture;

a gas connector configured to deliver the breathable gas to the central portion via the aperture, the gas connector being adapted to be positioned on top of the patient's head when the patient interface is worn, wherein the seal forming portion, the central portion and the conduits at least partly form a ring with a ring-shaped gas path, and at least a part of the gas connector that is relatively harder than the conduits is positioned within the ring-shaped gas path and between the inner and outer wall portions, and another part of the gas connector that is relatively harder than the conduits is positioned outside the ring-shaped gas path; and

a socket joint that removably connects the bottom portion of each said conduit to the seal forming portion to provide the breathable gas to the seal forming portion, each said socket joint including 1) a socket portion having a socket aperture, a seal ring, and a seal interface connector at least partly inserted within the bottom portion, and 2) a complementary formation that is removably received through the socket aperture and detachably engages with the seal interface connector and the seal ring, wherein each said seal ring sealingly engages with the complementary formation of the seal forming portion when the complementary formation is inserted into the socket portion.

45. The patient interface of claim 44, further comprising a rear strap connected to the conduits at a rear strap joint, said rear strap extending in a posterior direction to engage the occiput of the patient's head,

wherein:

the patient interface does not include additional conduit tubing and does not include an additional securement strap,

at least a portion of the gas connector is movably connected to the ring, and

23

the patient interface further comprises a swivel coupling device rotatably mounted to the gas connector, the swivel coupling device being adapted to connect to a gas supply tube adapted to deliver the supply of breathable gas to the gas connector.

46. The patient interface of claim 44, wherein:

the socket portion is formed on a bottom end of each bottom portion and the complimentary formation is formed as an extension of the seal forming portion, each said seal interface connector has 1) a first end extending into the bottom end to a position within the respective conduit, and 2) a second end that removably receives therein the complimentary formation, the seal ring is joined to the conduit, is positioned at the socket aperture, and extends in a radially inward direction from a circumferential wall of the socket portion.

47. The patient interface of claim 44, wherein:

the socket portion is formed on a bottom end of each bottom portion and the complimentary formation is formed as an extension of the seal forming portion, and each said seal interface connector has 1) a first end extending into the bottom end to a position within the respective conduit, and 2) a second end that removably receives therein the complimentary formation.

48. The patient interface of claim 44, wherein the seal ring is joined to the conduit, is positioned at the socket aperture, and extends in a radially inward direction from a circumferential wall of the socket portion.

49. The patient interface of claim 44, further comprising a rear strap connected to the conduits at a rear strap joint, said rear strap extending in a posterior direction to engage the occiput of the patient's head,

wherein the flexible side portions include at least a first section with at least a first flexible bellows, the at least first flexible bellows being configured to at least partly reduce the extent to which drag forces from a supply tube are transferred from the gas connector to the conduits, the at least first flexible bellows being positioned superior to the rear strap joint and having an inner surface that is curved to generally match the shape of the patient's head and configured to engage the patient's head.

50. A patient interface for delivering breathable gas under positive pressure to a patient for treatment of sleep disordered breathing, the patient interface comprising:

conduit headgear having a pair of flexible side conduits and a central portion having an inner wall portion to engage the top of the patient's head and an outer wall portion having a top aperture, wherein the side conduits and the central portion forming a one-piece construction of the same material;

a seal forming portion configured to receive the breathable gas from the conduit headgear and direct the breathable gas to the patient's airway, wherein the pair of flexible side conduits are configured to support the seal forming portion in a desired position on the patient's face, each said side conduit comprising a top portion in fluid communication with the top aperture and a bottom portion connected to, and in fluid communication with, a lateral side of the seal forming portion to deliver the breathable gas to the seal forming portion, each said side conduit being arranged to, in use, extend along and engage a respective side of the patient's head between the patient's eye and ear;

24

a gas connector attached to the central portion at the top aperture, the gas connector being configured to connect to a gas supply tube adapted to deliver a supply of breathable gas; and

5 a rear strap connected to the conduit headgear at a rear strap joint, said rear strap extending in a posterior direction to engage the occiput of the patient's head, wherein the conduit headgear includes at least a first section with at least a first flexible bellows, and a second section that does not include flexible bellows, each of the first and second sections being having a curved inner surface shaped to engage the patient's head in use, at least the at least first flexible bellows being configured to at least partly reduce the extent to which drag forces from the supply tube are transferred from the gas connector to the side conduits, and

wherein the seal forming portion, the central portion and the side conduits form a ring with a ring-shaped gas path, and at least a part of the gas connector that is relatively harder than the central portion is inserted into the top aperture and positioned within the ring-shaped gas path and between the inner and outer wall portions, and an exterior part of the gas connector that is relatively harder than the central portion is positioned outside the ring-shaped gas path.

51. The patient interface of claim 50, wherein the conduit headgear consists of the side conduits and the central portion and wherein each said side conduit includes at least one said at least first flexible bellows and at least one said second section without bellows.

52. The patient interface of claim 50,

wherein the at least first flexible bellows is positioned proximate the central portion and is configured to engage a portion of the patient's head superior to the rear strap joint, and

wherein the conduit headgear further comprising a third section including at least a second flexible bellows, wherein the second section without the flexible bellows is positioned between the first section and the second section.

53. The patient interface of claim 52, wherein the at least a second flexible bellows is positioned proximate one of the bottom portions.

54. The patient interface of claim 52, wherein the second section is positioned below said rear strap joint.

55. The patient interface of claim 50, further comprising a socket joint that removably connects the bottom portion of each said side conduit to the seal forming portion to provide the breathable gas to the seal forming portion, each said socket joint including 1) a socket portion having a socket aperture, a seal ring, and a seal interface connector at least partly inserted within the bottom portion, and 2) a complementary formation that is removably received through the socket aperture and detachably engages with the seal interface connector and the seal ring, wherein each said seal ring sealingly engages with the complementary formation of the seal forming portion when the complementary formation is inserted into the socket portion.

56. The patient interface of claim 55, wherein the socket portion is formed on a bottom end of each bottom portion and the complimentary formation is formed as an extension of the seal forming portion,

wherein each said seal interface connector has 1) a first end extending into the bottom end to a position within the respective side conduit, and 2) a second end that removably receives therein the complementary formation,

wherein the seal ring is joined to the conduit, is positioned at the socket aperture, and extends in a radially inward direction from a circumferential wall of the socket portion.

57. The patient interface of claim 50, wherein: the patient interface does not include additional conduit tubing and does not include an additional securement strap;

at least a portion of the gas connector is movably connected to the central portion, and

the patient interface further comprises a swivel coupling device rotatably mounted to the exterior part of the gas connector, the swivel coupling device being adapted to connect to the gas supply tube.

58. A patient interface for delivering breathable gas under positive pressure to a patient for treatment of sleep disordered breathing, the patient interface comprising:

conduit headgear having a pair of flexible side conduits and a central portion having an inner wall portion to engage the top of the patient's head and an outer wall portion having a top aperture, wherein the side conduits and the central portion form a one-piece construction of the same material;

a seal forming portion configured to receive the breathable gas from the conduit headgear and direct the breathable gas to the patient's airway, wherein the pair of flexible side conduits are configured to support the seal forming portion in a desired position on the patient's face, each said side conduit comprising a top portion in fluid communication with the top aperture and a bottom portion connected to, and in fluid communication with, a lateral side of the seal forming portion to deliver the breathable gas to the seal forming portion, each said side conduit being arranged to, in use, extend along and engage a respective side of the patient's head between the patient's eye and ear;

a gas connector attached to the central portion at the top aperture, the gas connector being configured to connect to a gas supply tube adapted to deliver breathable gas to the central portion; and

wherein the seal forming portion, the central portion and the side conduits form a ring with a ring-shaped gas path, and at least a part of the gas connector that is relatively harder than the central portion is inserted into the top aperture and positioned within the ring-shaped gas path and between the inner and outer wall portions, and an exterior part of the gas connector that is relatively harder than the central portion is positioned outside the ring-shaped gas path.

59. The patient interface of claim 58, wherein the conduit headgear includes at least a first section with at least a first flexible bellows, and a second section that does not include flexible bellows, each of the first and second sections being having a curved inner surface shaped to engage the patient's head in use, at least the at least first flexible bellows being configured to at least partly reduce the extent to which drag forces from the supply tube are transferred from the gas connector to the side conduits.

60. The patient interface of claim 59, wherein the conduit headgear consists of the side conduits and the central

portion, and wherein each said side conduit includes at least one said at least first flexible bellows and at least one said second section without bellows.

61. The patient interface of claim 60, further comprising a rear strap connected to the conduit headgear at a rear strap joint, said rear strap extending in a posterior direction to engage the occiput of the patient's head,

wherein the at least first flexible bellows is positioned proximate the central portion and is configured to engage a portion of the patient's head superior to the rear strap joint, and

wherein the conduit headgear further comprising a third section including at least a second flexible bellows, wherein the second section without the flexible bellows is positioned between the first section and the second section.

62. The patient interface of claim 61, wherein the at least a second flexible bellows is positioned proximate one of the bottom portion.

63. The patient interface of claim 61, wherein the second section is positioned below said rear strap joint.

64. The patient interface of claim 58, further comprising a socket joint that removably connects the bottom portion of each said side conduit to the seal forming portion to provide the breathable gas to the seal forming portion, each said socket joint including 1) a socket portion having a socket aperture, a seal ring, and a seal interface connector at least partly inserted within the bottom portion, and 2) a complementary formation that is removably received through the socket aperture and detachably engages with the seal interface connector and the seal ring, wherein each said seal ring sealingly engages with the complementary formation of the seal forming portion when the complementary formation is inserted into the socket portion.

65. The patient interface of claim 64, wherein the socket portion is formed on a bottom end of each bottom portion and the complimentary formation is formed as an extension of the seal forming portion,

wherein each said seal interface connector has 1) a first end extending into the bottom end to a position within the respective side conduit, and 2) a second end that removably receives therein the complementary formation,

wherein the seal ring is joined to the conduit, is positioned at the socket aperture, and extends in a radially inward direction from a circumferential wall of the socket portion.

66. The patient interface of claim 58, wherein: the patient interface does not include additional conduit tubing and does not include an additional securement strap;

at least a portion of the gas connector is movably connected to the central portion, and

the patient interface further comprises a swivel coupling device rotatably mounted to the exterior part of the gas connector, the swivel coupling device being adapted to connect to the gas supply tube.