



US00D697166S

(12) **United States Design Patent**
Martinson

(10) **Patent No.:** **US D697,166 S**

(45) **Date of Patent:** **** Jan. 7, 2014**

(54) **PORTABLE CAMOUFLAGE ASSEMBLY**

DESCRIPTION

- (71) Applicant: **Eric Stanton Martinson**, Almond, WI (US)
- (72) Inventor: **Eric Stanton Martinson**, Almond, WI (US)
- (**) Term: **14 Years**
- (21) Appl. No.: **29/433,584**
- (22) Filed: **Oct. 2, 2012**
- (51) **LOC (10) CI.** **22-99**
- (52) **U.S. CI.**
USPC **D22/199**
- (58) **Field of Classification Search**
USPC D22/125, 199; 43/1; 135/90, 115, 117,
135/120.4, 901; 182/16, 187; 428/8, 195.1,
428/919
See application file for complete search history.

FIG. 1 is a perspective view of the portable camouflage assembly illustrating the manner in which my new design may be employed;

FIG. 2 is a perspective view of the branch holder enlarged from those shown in FIG. 1 for clarity;

FIG. 3 is a top view of the engirdling strap of my new design, the bottom view opposite being a mirror image;

FIG. 4 is a left side view of the engirdling strap of my new design, the right side opposite being a mirror image;

FIG. 5 is an exploded side view of exemplary upper and lower grommet members of my new design, all sides of each respectively being identical from a radial perspective;

FIG. 6 is a right side view of a grommet and engirdling strap, the left side opposite being a mirror image;

FIG. 7 is a top view of an exemplary lower grommet member, the bottom view opposite being a mirror image;

FIG. 8 is a top view of an exemplary upper grommet member, the bottom view opposite being a mirror image;

FIG. 9 is a top view of the cinching strap and cinching clamp of my new design;

FIG. 10 is a right side view of the cinching strap and cinching clamp of my new design, the left side opposite being a mirror image;

FIG. 11 is bottom view of the cinching strap and cinching clamp of my new design;

FIG. 12 is a perspective view of the cinching clamp and a portion of the cinching strap of my new design;

FIG. 13 is a perspective view of a S-hook connector and a portion of the engirdling strap top and grommet of my new design;

FIG. 14 is a rear view a of a branch holder showing the O-ring groove, receptor, stop flange, neck and retention head of my new design;

FIG. 15 is a bottom view a of a branch holder showing a receptor;

FIG. 16 is a cross sectional view of the bottom of the branch holder receptor portion shown along line 16-16 of FIG. 14;

FIG. 17 is a diagonal cross sectional slice of the branch holder shown along line 17-17 of FIG. 14;

FIG. 18 is a cross sectional view of the top portion of the branch holder shown along line 18-18 of FIG. 14;

(56) **References Cited**

U.S. PATENT DOCUMENTS

3,616,105	A	10/1971	Marks	
4,517,230	A	5/1985	Crawford	
4,782,616	A	11/1988	Hambleton	
4,813,441	A	3/1989	Kepley	
4,937,109	A	6/1990	Lin	
5,669,403	A *	9/1997	Belcher et al.	135/90
6,058,685	A	5/2000	Wotring	
6,116,563	A	9/2000	Tsai	
6,306,471	B1	10/2001	Pitman et al.	
6,708,340	B1	3/2004	Dondero	
7,051,839	B1	5/2006	George	
7,100,626	B2 *	9/2006	Livacich	135/90
7,568,492	B1 *	8/2009	Helmer	135/117

* cited by examiner

Primary Examiner — Catheri Oliver-Garcia
(74) Attorney, Agent, or Firm — Loyd W. Bonneville, Atty

(57) **CLAIM**
The ornamental design for a portable camouflage assembly, as shown and described.

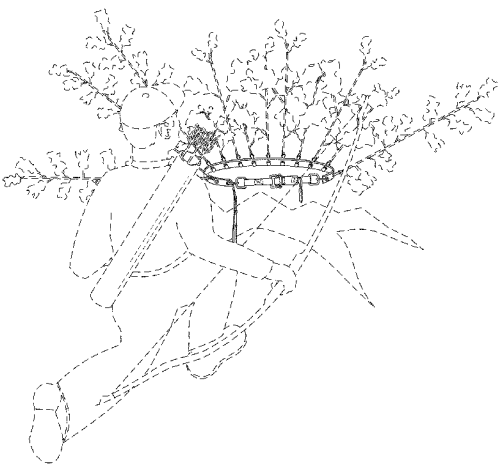

FIG. 19 is a top view a of a branch holder showing the head and stop flange;

FIG. 20 is a top view a of the O-ring of a branch holder, the bottom view opposite being a mirror image;

FIG. 21 is a right side view of the O-ring of my new design, all sides of each respectively being identical from a radial perspective;

FIG. 22 is a right side view of a branch holder showing the O-ring groove, receptor, stop flange, neck and retention head of my new design together with a portion of the engirdling strap and a grommet;

FIG. 23 is a perspective view of a branch holder; and, FIG. 24 is a rear view a of a branch holder showing the O-ring groove, receptor, stop flange, neck and retention head of my new design illustrating the manner in which my new design may be employed.

The broken lines in FIG. 1 and FIG. 24 illustrate environmental structure which form no part of the claimed design.

Portions of the engirdling strap are shown broken away for convenience of illustration or to indicate indeterminate length.

1 Claim, 5 Drawing Sheets

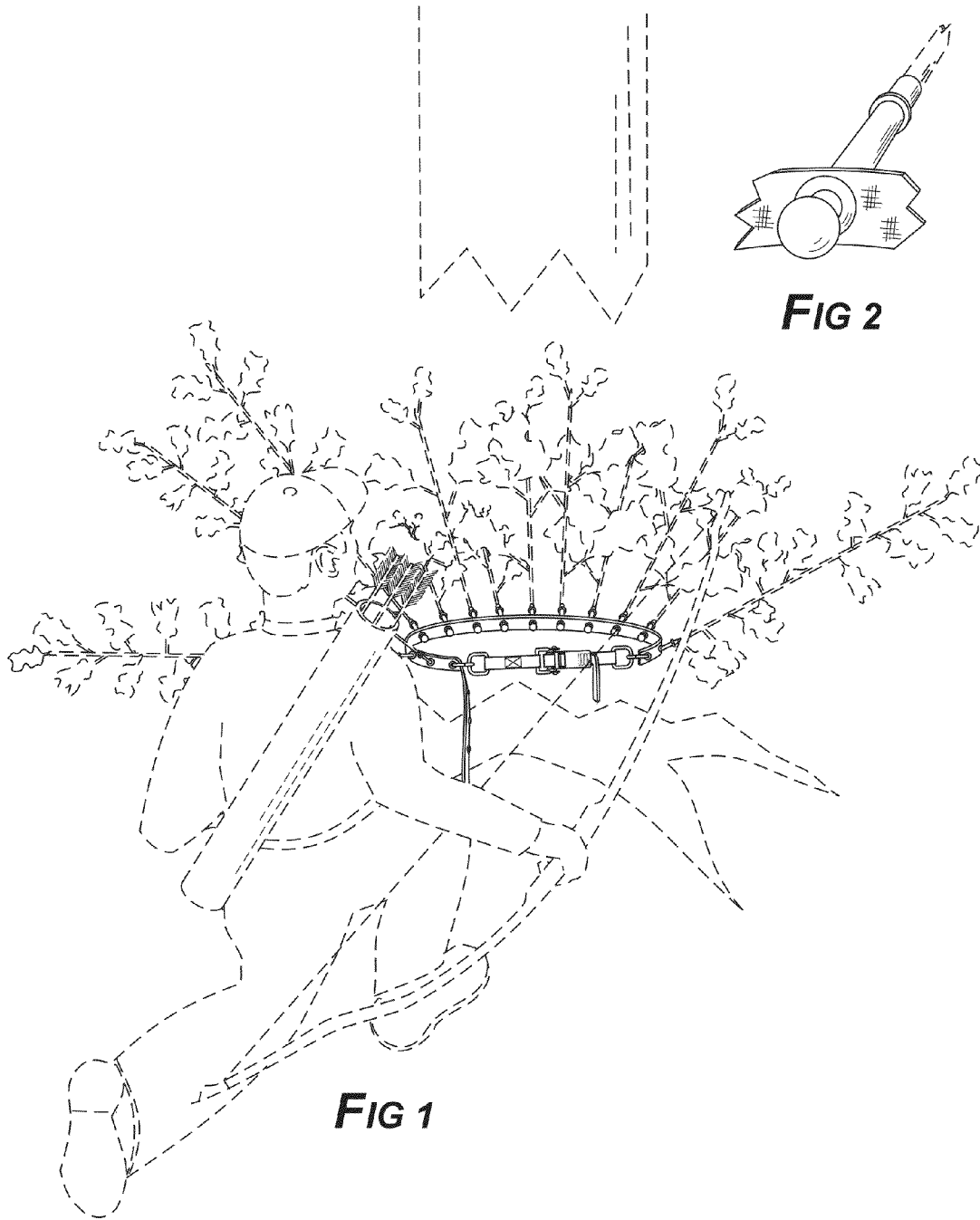

FIG 2

FIG 1

FIG 3



FIG 4



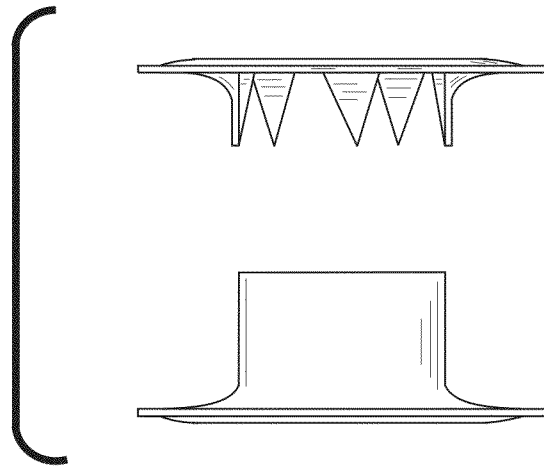

FIG 5

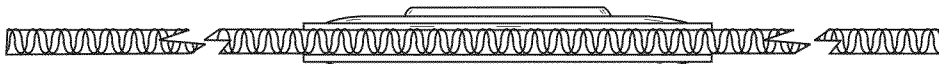

FIG 6

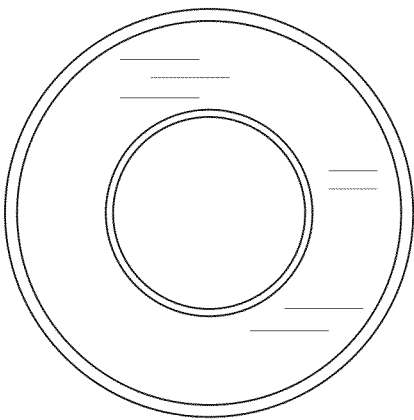

FIG 7

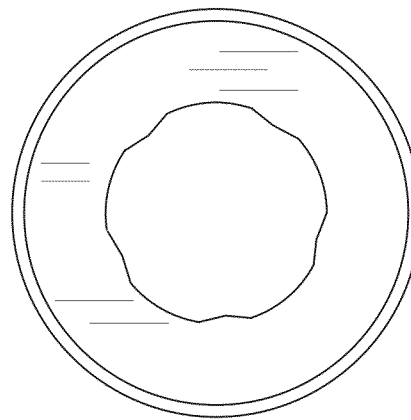

FIG 8

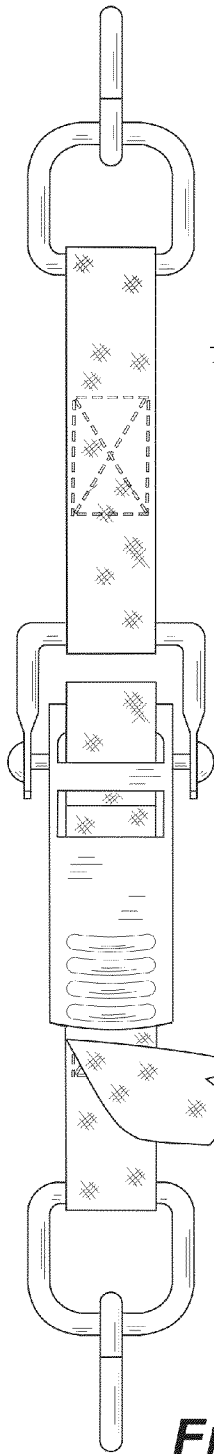

FIG 9

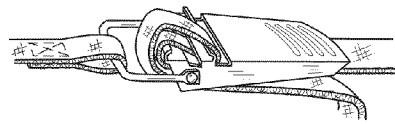

FIG 12

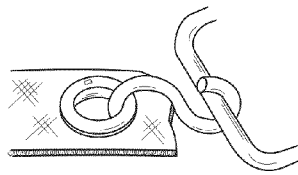

FIG 13

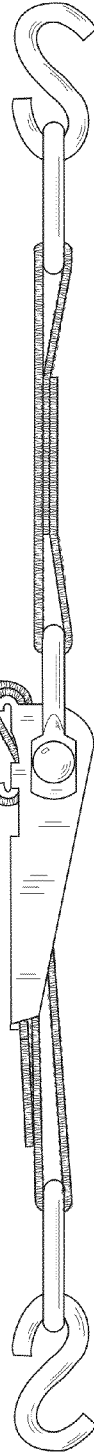

FIG 10

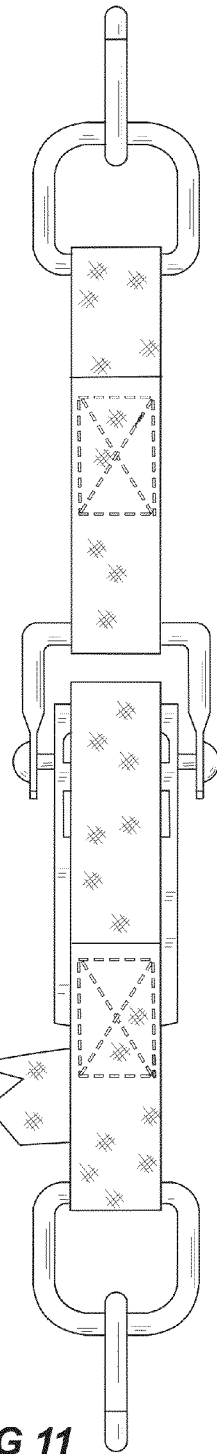

FIG 11

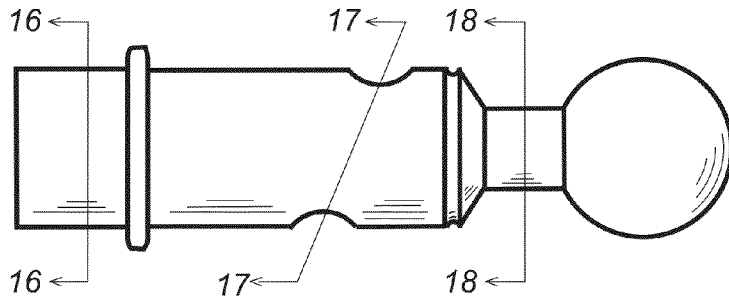

FIG 14

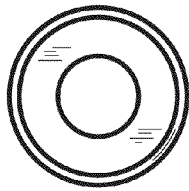

FIG 15

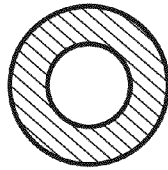

FIG 16

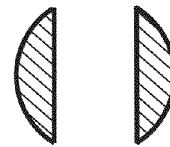

FIG 17

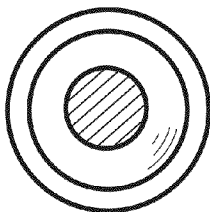

FIG 18

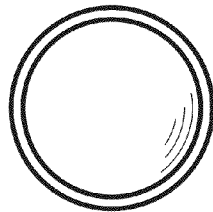

FIG 19

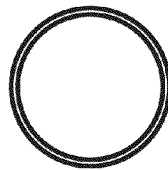

FIG 20



FIG 21

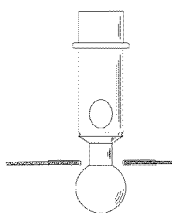

FIG 22

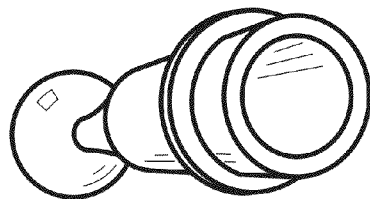

FIG 23

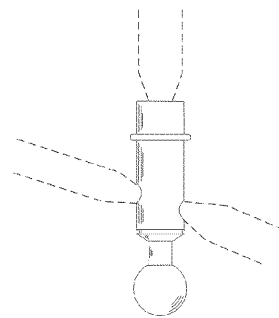

FIG 24