

INTERNATIONAL APPLICATION PUBLISHED UNDER THE PATENT COOPERATION TREATY (PCT)

<p>(51) International Patent Classification ⁷ : H04N 1/00, 1/21</p>	<p>A2</p>	<p>(11) International Publication Number: WO 00/30338</p> <p>(43) International Publication Date: 25 May 2000 (25.05.00)</p>								
<p>(21) International Application Number: PCT/US99/26846</p> <p>(22) International Filing Date: 12 November 1999 (12.11.99)</p> <p>(30) Priority Data:</p> <table border="0"> <tr> <td>60/108,348</td> <td>13 November 1998 (13.11.98)</td> <td>US</td> </tr> <tr> <td>09/299,768</td> <td>25 April 1999 (25.04.99)</td> <td>US</td> </tr> <tr> <td>60/162,965</td> <td>28 October 1999 (28.10.99)</td> <td>US</td> </tr> </table> <p>(71) Applicant: SILICON FILM TECHNOLOGIES, INC. [US/US]; 16265 Laguna Canyon Road, Irvine, CA 92618 (US).</p> <p>(72) Inventors: STERN, Jonathan, Michael; 513 Baypointe Drive, Newport Beach, CA 92660 (US). MIFFLIN, Robert; 4818 South Mission, Fallbrook, CA 92028 (US). CARLSON, Randy; 4081 Kings Canyon Road, Carson City, NV 89703 (US). HORNBACK, William, B.; 2 Windy Ridge, Trabuco Canyon, CA 92678 (US). SAPIR, Itzhak; 19 Hickory, Irvine, CA 92614 (US). WHALEN, Matthew, S.; 25695 Lacima, Laguna Niguel, CA 92677 (US). WEBBER, Robert, I.; 22 Dewberry Way, Irvine, CA 92612 (US). PROKOP, Alexander; 1350 Davidson Way, Reno, NV 89509 (US). SHEEHY, Finbar, T.; 11800 Goshen Avenue #204, Los Angeles, CA 90049 (US).</p>	60/108,348	13 November 1998 (13.11.98)	US	09/299,768	25 April 1999 (25.04.99)	US	60/162,965	28 October 1999 (28.10.99)	US	<p>(74) Agent: SIMPSON, Andrew, H.; Knobbe, Martens, Olson & Bear, 16th floor, 620 Newport Center Drive, Newport Beach, CA 92660-8016 (US).</p> <p>(81) Designated States: AL, AM, AT, AU, AZ, BA, BB, BG, BR, BY, CA, CH, CN, CR, CU, CZ, DE, DK, DM, EE, ES, FI, GB, GD, GE, GH, GM, HR, HU, ID, IL, IN, IS, JP, KE, KG, KP, KR, KZ, LC, LK, LR, LS, LT, LU, LV, MA, MD, MG, MK, MN, MW, MX, NO, NZ, PL, PT, RO, RU, SD, SE, SG, SI, SK, SL, TJ, TM, TR, TT, TZ, UA, UG, UZ, VN, YU, ZA, ZW, ARIPO patent (GH, GM, KE, LS, MW, SD, SL, SZ, TZ, UG, ZW), Eurasian patent (AM, AZ, BY, KG, KZ, MD, RU, TJ, TM), European patent (AT, BE, CH, CY, DE, DK, ES, FI, FR, GB, GR, IE, IT, LU, MC, NL, PT, SE), OAPI patent (BF, BJ, CF, CG, CI, CM, GA, GN, GW, ML, MR, NE, SN, TD, TG).</p> <p>Published <i>Without international search report and to be republished upon receipt of that report.</i></p>
60/108,348	13 November 1998 (13.11.98)	US								
09/299,768	25 April 1999 (25.04.99)	US								
60/162,965	28 October 1999 (28.10.99)	US								

(54) Title: ELECTRONIC FILM SYSTEM AND METHOD OF FILM PROCESSING

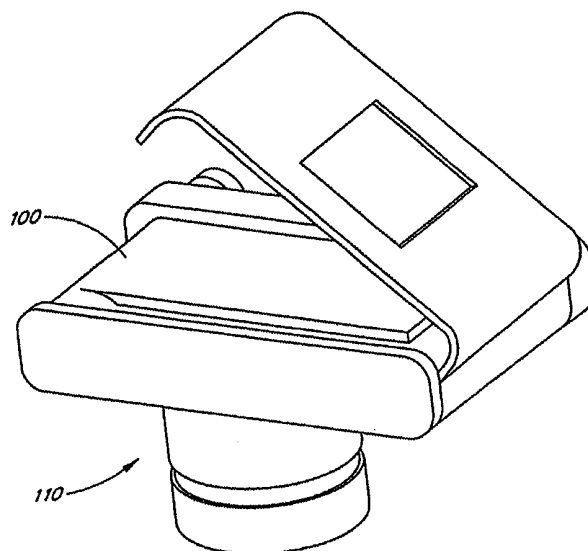

(57) Abstract

An electronic film system is described. The electronic film system provides for the capturing, displaying, editing, storing, transmitting, receiving, and manipulating of electronic images. The electronic film system includes an electronic film cartridge for the capture and storage of electronic images. The electronic film system also includes a carrier for housing the electronic film cartridge when the cartridge is not located in a camera. The electronic film system also includes a storage module for storing, displaying, editing, manipulating, and transmitting electronic images. The electronic film system also includes a method for transmitting and receiving electronic images over a communication network for storage or processing at a remote location.

FOR THE PURPOSES OF INFORMATION ONLY

Codes used to identify States party to the PCT on the front pages of pamphlets publishing international applications under the PCT.

AL	Albania	ES	Spain	LS	Lesotho	SI	Slovenia
AM	Armenia	FI	Finland	LT	Lithuania	SK	Slovakia
AT	Austria	FR	France	LU	Luxembourg	SN	Senegal
AU	Australia	GA	Gabon	LV	Latvia	SZ	Swaziland
AZ	Azerbaijan	GB	United Kingdom	MC	Monaco	TD	Chad
BA	Bosnia and Herzegovina	GE	Georgia	MD	Republic of Moldova	TG	Togo
BB	Barbados	GH	Ghana	MG	Madagascar	TJ	Tajikistan
BE	Belgium	GN	Guinea	MK	The former Yugoslav Republic of Macedonia	TM	Turkmenistan
BF	Burkina Faso	GR	Greece	ML	Mali	TR	Turkey
BG	Bulgaria	HU	Hungary	MN	Mongolia	TT	Trinidad and Tobago
BJ	Benin	IE	Ireland	MR	Mauritania	UA	Ukraine
BR	Brazil	IL	Israel	MW	Malawi	UG	Uganda
BY	Belarus	IS	Iceland	MX	Mexico	US	United States of America
CA	Canada	IT	Italy	NE	Niger	UZ	Uzbekistan
CF	Central African Republic	JP	Japan	NL	Netherlands	VN	Viet Nam
CG	Congo	KE	Kenya	NO	Norway	YU	Yugoslavia
CH	Switzerland	KG	Kyrgyzstan	NZ	New Zealand	ZW	Zimbabwe
CI	Côte d'Ivoire	KP	Democratic People's Republic of Korea	PL	Poland		
CM	Cameroon	KR	Republic of Korea	PT	Portugal		
CN	China	KZ	Kazakistan	RO	Romania		
CU	Cuba	LC	Saint Lucia	RU	Russian Federation		
CZ	Czech Republic	LI	Liechtenstein	SD	Sudan		
DE	Germany	LK	Sri Lanka	SE	Sweden		
DK	Denmark	LR	Liberia	SG	Singapore		
EE	Estonia						

ELECTRONIC FILM SYSTEM AND METHOD OF FILM PROCESSING

Background of the Invention

Field of the Invention

15 The invention relates to portable devices for capturing, displaying, editing, storing, transmitting, receiving, and manipulating digital images.

Background

 Historically, computer users who wanted to create digital images on a computer screen would start with a conventional photographic image on a print, negative, or slide.
20 The photographic image was then converted into a digital image by using a scanner to scan the photographic image into a computer.

 The introduction of the digital camera allowed users to bypass the film development and scanning process. With a digital camera, the user simply takes a picture and downloads the picture into a computer. The image quality of the early digital cameras
25 was poor, and the cameras themselves were very expensive. Thus, for a time, many photographers both amateur and professional continued to use conventional film photography. Recently, the quality of the photographs produced by digital cameras has improved dramatically, and the price of the digital cameras has declined to the point where a digital camera is a consumer item used by professional and amateur photographers.
30 Many observers and photographers now predict that, in the near future, electronic photography will replace conventional film photography for most purposes.

However, the digital camera, while providing many benefits over a conventional film camera does have some drawbacks. One of the biggest drawbacks is that the digital images cannot be placed in a photo album like a normal photograph. The digital images are, in a sense, less portable than regular photographs because a computer with a display screen is needed to view the digital images. This makes it difficult for photographers, especially amateur photographers showing family and vacation pictures, to show their photographs to others. In addition, many digital cameras have limited storage capability and cannot store a large number of digital images.

Summary of the Invention

The present invention solves these and other problems by providing a portable electronic photo storage module (also referred to as “electronic photo album” or “memory book”) configured to store and display digital images. The electronic photo storage module (hereinafter referred to as “storage module”) provides a memory for storing the digital images, a processor to process the images, a display to show the images, and a method to transmit the images over the Internet. The storage module also provides an interface to a source of digital images. Sources of images include digital cameras, computers, floppy discs, flash RAM cards, and the like.

The storage module provides a convenient way to share electronic photographs with the same ease that conventional photographs are shared and exchanged. The storage module electronically displays images that have been captured and processed by a digital camera, computer, and the like. The storage module can be used to transport thousands of digital images and to display those digital images in different forms for different users. The storage module stores the digital images on a mass storage device such as a hard disc, a flash memory, and the like. On user command, the storage module displays the stored images on the display. In one embodiment, the storage module provides an output signal to display the images on an external display device such as a television, computer monitor, projector, virtual-reality display, printer, etc. The storage module can provide digital image output directly or indirectly to photo printers, the Internet, and a photo kiosk that provides printing services for digital images.

In one embodiment, the storage module is configured to contain electronic

components, connectors, batteries, and an interface to an electronic film unit. In one version, a direct connection is provided between the electronic film unit readout connector and a computer via connectors and wiring. In other versions, interfaces to a PCMCIA port that contain memory circuits with card type/identifying data, a USB Port controller or even a telephone or network modem may be included within the storage module.

The storage module can be configured with memory (flash memory, for example) and with data transfer and control means to transfer data from an inserted electronic film unit into the storage module memory and then erase the electronic film unit memory, allowing for immediate reuse of the electronic film unit to take additional pictures. The storage module, with or without the electronic film, may be connected to a computer so that the data can be transferred to the computer and the memory within the storage module (and electronic film unit, if present) can be erased. This configuration is useful, for example, when traveling and direct computer download of each electronic film unit "roll" of pictures is not convenient.

In yet another embodiment, the storage module includes a processor to compress and store images. As a further extension of the above storage module configuration, the processor can perform image-processing functions prior to storing of the images into the memory of the storage module.

Image data from the electronic film unit can be compressed using JPEG, Wavelet, Fractal, or other compression algorithms as part of the storage process. This has the advantage of reducing the amount of data stored and conversely increasing the capacity of the image storage capacity of the storage module.

In one version, the present system is an integrated approach to providing a storage module that can be used to transport thousands of images and to display those images in different forms for different people, with a built-in display capability for looking at the images. The system can receive images from the electronic film system (E-Film), from computers, from digital cameras, or from the Internet, or virtually any way the user wants to input the digital image. The system stores the images on a mass storage device(s) such as hard drives, floppy discs, electronic flash drives or other current and future types of mass storage media. The system, on command, displays the images on its built-in screen for people to look at and to share. It can output the images

to other types of displays such as televisions, PC monitors, and export them to the web to be shown to other people on the Internet or through the projector-type of image displays which interface with PC's. In addition, the user can output images to print systems that can make hard copies. The storage module can output either directly or indirectly to photo printers, directly or indirectly via the web to a printing organization, or output directly to something like a photo kiosk which provide printing services of digital images (similar to those that are built by Kodak, Fuji, and others).

In one embodiment, the storage module provides portability, size, and the uniqueness of the storage module functionality. It stores, displays, and provides a means of sharing thousands of images.

In one version, the storage module includes a means for capturing electronic imagery from digital imaging devices or sources, displaying and/or processing those images, editing the images (optionally), and sharing the images with other media or directly with other people. Other media include computers, televisions, printers, web sites and/or developers as well as any unnamed or future versions of image media and the like. In one aspect, the storage module is a large photo album that accepts digital images and then allows a person to share those images with other people.

In one embodiment, size and portability are features of the concept. In one embodiment, the storage module is very small, on the order of the size of a large paperback novel that can hold thousands of images, transport the images, and share the images with other people. In addition, the user can flip through images and albums just as he or she would through a traditional album or stack of albums. In one embodiment, within the storage module, there are multiple albums. A user can choose which album to share with what individuals on what date.

The storage module includes an input port of sufficient bandwidth to easily import the images; sufficient data storage space for image storage; and a display mechanism for the digital image display. The storage module provides a convenient way to manage the increasing amount of imagery available throughout the world which is only available in digital form, and has never been reduced to a negative or to a print. Thus, the storage module becomes a natural adjunct system for digital image sharing.

An Electronic Film System (EFS), including an Electronic Film (E-film) unit (or

cartridge) and an EFS carrier intended to protect and contain the E-film cartridge when it is not in a camera is also described. Several features incorporated into this case offer important and unique capabilities.

5 In one embodiment, the carrier is formed with a flat protrusion that both surrounds the "flag" feature of the E-film unit and conforms to the mechanical form factor of a type II PCMCIA data card with a standard PCMCIA connector and keying features at its end. Electrical connections and (as necessary) electronic processing means within the carrier connect the E-film unit electrically to the PCMCIA connector in such a way that image data from the E-film unit can be electronically read out and otherwise controlled through
10 the PCMCIA connector and interface.

In one embodiment, the carrier that encloses the "film can" portion of the E-film unit is oriented towards the "top" surface of the PCMCIA adapter. This orientation facilitates the insertion of the Carrier into the PCMCIA receptacle of a typical notebook computer while the computer is resting on a surface.

15 The carrier is configured (in some embodiments) to contain electronic components, connectors, batteries, etc. that implement interface(s) between the E-film unit contained within the carrier and/or between the carrier and other external devices. In one version, a direct connection is provided between the E-film unit readout connector and a computer via connectors and wiring. In other versions, interfaces to a PCMCIA port that
20 contain memory circuits with card type/identifying data, a USB Port controller or even a telephone or network modem can be included within the carrier.

The carrier can be configured with memory (flash memory, for example) and with data transfer and control means to transfer data from an inserted E-film unit into the carrier memory and then erase the E-film unit memory, allowing for immediate reuse of the E-
25 film unit to take additional pictures. The carrier, with or without the E-film, may be inserted into a computer's PCMCIA slot (or connected to a computer's other interface ports or to a network interface) and the data transferred and the memory within the carrier (and E-film unit, if present) erased. This configuration is useful, for example, when traveling and direct computer download of each E-film unit "roll" of pictures is not
30 convenient.

In yet another embodiment, a storage module includes a processor to compress and

store images. As a further extension of the above storage module configuration, the processor can:

- (1) perform dark current correction;
- (2) perform bad line, bad pixel, and/or bad memory cell correction by

5 interpolation; and

- (3) perform image processing functions prior to storing of the images into the memory of the storage module.

Image data from the E-film unit can be compressed using JPEG, Wavelet, Fractal, or similar compression algorithms as part of the storage process. This has the advantage
10 of reducing the amount of data stored and conversely increasing the capacity of the image storage capacity of the storage module.

One embodiment includes compression of the individual RED/GREEN/BLUE color planes of the image data prior to the image processing steps of interpolation and interlacing normally used to produce a completed color image. This gains a factor of 3:1
15 reduction of the beginning data sets, which is largely preserved when compressing the file.

Brief Description of the Figures

The various embodiments of the invention are described below in connection with the following figures.

20 Figure 1 shows an electronic film cartridge that fits within a film cavity of a standard 35 mm camera.

Figure 2 shows an alternate view of the electronic film cartridge.

Figures 3A-3C show a storage module having a first case style, a connector for an electronic film cartridge (or other source of digital images) and a display for viewing the
25 images.

Figures 3D-3F show a storage module having a second case style, a connector for an electronic film cartridge (or other source of digital images) and a display for viewing the images.

Figure 4 shows a block diagram of the storage module.

30 Figure 5 is a flowchart showing user interaction with the storage module.

Figure 6 is a block diagram that shows one embodiment of the logical storage of images as one or more logical volumes (logical albums) in a storage module.

Figure 7A is a flowchart that illustrates input-output data flow in the storage module.

5 Figure 7B is a flowchart that illustrates image processing in the storage module.

Figure 8 shows one embodiment of an electronic film cartridge within a film cavity of a standard 35 mm camera.

Figure 9 shows another view of an electronic film cartridge.

Figures 10A-10C show additional views of an electronic film cartridge.

10 Figure 11 is a block diagram showing one embodiment of an electronic film cartridge.

Figures 12A-12B show a flowchart that illustrates an image capture sequence.

Figures 13A-13C show one embodiment of a carrier.

Figures 14A-14B show one embodiment of a storage module.

15 Figures 16A-16B show another embodiment of a storage module.

Figure 17 is a block diagram that shows the functional relationships between the components of one embodiment of an electronic film system.

Figure 18 is a block diagram that shows the functional relationships between the components of another embodiment of an electronic film system.

20 Figure 19 is a flowchart that illustrates the operation of one embodiment of the storage module.

Figure 20 is a flowchart that illustrates the operation of the storage module during the "Review/Select Images" menu option.

25 Figure 21 is a flowchart that illustrates the operation of the storage module during the "Slide Show from Memory Card" menu option.

Figure 22 is a flowchart that illustrates the operation of the storage module during the "Send Images to Host/Memory Card" menu option.

Figure 23 is a flowchart that illustrates the operation of the storage module during the "Upload Images to Memory Card from Host" menu option.

30 Figure 24 is a flowchart that illustrates the operation of the storage module during the "Delete All Images" menu option.

Figure 25 is a block diagram that shows the functional relationships between the components of one embodiment of an electronic film system.

Figure 26 is a flowchart that illustrates the operation of the storage module during the "Send Images to Internet" menu option.

5 Figure 27 is a flowchart that illustrates the operation of the central server during the transmission of images over the communication network.

Figure 28 is a flowchart that illustrates a method of recording and developing pictures in accordance with the present invention.

10 Figure 29 is a flowchart that illustrates another method of recording and developing pictures in accordance with the present invention.

Detailed Description of the Preferred Embodiments

One embodiment of the invention is used in connection with an electronic film cartridge 100 shown in Figure 1. The electronic film cartridge 100 fits within a film cavity of a camera 110 such as a standard 35 mm camera. The electronic film cartridge 100 is preferably shaped so that it can mate directly with the camera 110 without modifications being made to the camera. Placing the electronic film cartridge 100 into the camera 110 effectively turns the camera into a digital camera, offering the user the ability to rapidly switch between conventional and electronic photography, while still providing the user the freedom to use camera attachments and other lenses. This offers the user both simplicity and convenience.

Another view of the electronic film cartridge 100 is shown in Figure 2. The cartridge 100 is advantageously capable of recording quality images with over 1.0 megapixel resolution, and includes a nonvolatile storage (e.g., flash memory) capable of storing many full resolution pictures. The cartridge 100 may be reused many times, resulting in significant savings in film and film development. When it is not in use, the cartridge 100 is preferably stored in a molded carrying case (not shown). To load the cartridge 100 into the camera 110, the cartridge is taken out of the carrying case and placed into the body of the camera like a conventional roll of film, with the cartridge 100 being self-seating within the camera. Once the camera 110 is closed, the user is ready to take pictures. A visible

display 120 on the cartridge 100 confirms that the cartridge is ready to record the next picture (generally within 2 seconds of the picture just recorded), and this may be confirmed by an audible signal from the cartridge 100. The display 120 also preferably provides a shot counter, and the electronic film cartridge 100 alerts the user with an audible alarm when the system is full. In one embodiment, the photographic speed (ASA) of the electronic film may be 64 or greater.

Pictures, as digital images, recorded electronically are advantageously stored and viewed using a storage module 130 as shown in Figures 3A-3F. A first case style is shown in Figure 3A-3C, a second case style is shown in Figures 3D-3F. The storage module 130 has a cavity for accepting the electronic film cartridge 100, a flash ram card, a floppy disc, flash ram, or other storage device suitable for storing digital images. To facilitate data transfer between the cartridge 100 and the storage module 130, the cartridge 100 typically includes electrical contacts that mate with electrical contacts in the storage module 130 when the cartridge is properly inserted into the storage module. The electrical contacts are connected to an interface within the storage module 130, with at least one battery 303 supplying power to the electronics within the storage module. The storage module 130 can advantageously transmit or receive digital images over telephone lines to the Internet using a built-in modem and a phone jack 320 (e.g., an RJ-11 jack).

In one embodiment, the storage module 130 stores many pictures, which are displayed on a display 200, as illustrated in Figure 3A-3F. Using control buttons or knobs 220, a user can select stored picture for viewing. In one embodiment, the storage module 130 functions as a multi-volume photo album, and the memory within the storage module may be advantageously partitioned into several volumes, (e.g., multiple photo albums). The user has the option of selecting one of a number of industry standard formats for the images: JPEG, FLASHPIX, BMP, etc. The storage module 130 preferably further comprises a set of icons on the display and/or, optionally, other indicators (e.g., light emitting diodes or "LEDs") which indicate the status of the electronic processing, as described in greater detail below in connection with Figure 6.

The storage module 130 can also be used to share digital images by several methods. One such sharing method includes downloading images to a home computer and uploading images from a home computer. Optional sound files associated with the

digital images can also be uploaded and downloaded to the computer.

A cartridge door 333, shown closed in Figure 3D, and open in Figures 3E and 3F, is provided with the second case style to cover the opening where the electronic film cartridge 100 is inserted. The cartridge door 333 can also be provided with the first case style shown in Figures 3A-3C.

Figure 4 is a block diagram showing the functional components of the storage module 130. In Figure 4, an external storage device 400 is provided to an interface 410 that is linked to a central processing unit (CPU) 420. The external storage device 400 can be an electronic film cartridge 100, a floppy disc, a miniature floppy disc, a flash ram, a solid state floppy disc card (SSFDC), a disc drive, an electronic camera, or any other data storage device. The CPU 420 is in communication with a memory 430 and an internal storage device 430. The CPU 420 is also in communication with a display screen 200, an optional external display interface 450, and an optional computer interface 460. The computer interface 460 provides connection to an external computer 404. The computer interface 460 can be a parallel port interface, a serial port interface, a Universal Serial Bus (USB) interface, a FireWire interface (e.g., IEEE-1394), an ethernet interface, a network interface, a radio frequency (RF) interface, an infrared interface, a PCMCIA port, and the like. The external computer 404 can be another storage module, thereby allowing the sharing of images between photo albums. The computer 404 can also be a desktop personal computer or laptop. The external computer 404 can be provided with an interface to a communications network 441, such as the Internet, thereby allowing the storage module 130 to indirectly download and upload pictures via the network (i.e., Internet) through the computer 404.

User commands from controls 464 are provided to the CPU 420. A power management system 462 supplies power to the various functional blocks of the storage module 130 on an as-needed basis to conserve power.

In one version, the CPU 420 is also linked to an optional modem 440 through which data, including images and sound files, may be downloaded to a communications network 441 without the need for the computer 404. The communications network 441 can be the Internet, an intranet, and the like. The modem 440 can be configured to provide a connection through a Public Switched Telephone Network (PSTN), an Integrated

Services Digital Network (ISDN), a cellular telephone network (including analog and digital systems), a satellite communications network (including, for example, the Iridium system), a cable television system and the like. The communication network 441 can be connected to a remote site 490 that is configured to store, print, and/or display the images.

5 The storage module 130 can also include an optional audio output system 470, which includes a digital-to-analog converter 471, an amplifier 472 and a loudspeaker (and/or headphone connector) 473. An output of the processor 420 provides digital audio data to a digital input of the digital-to-analog converter 471. An analog output of the digital-to-analog converter 471 is provided to an input of the amplifier 472 and an output
10 of the amplifier 472 is provided to the loudspeaker 473.

 When a picture is viewed on the display 200, the audio system 470 can be used to play a digital-audio sound clip associated with the picture being viewed. The audio system 470 can also be used to provide user interface functions, such as a low-battery beep, a memory-full beep, etc.

15 The display 200 includes, for example, flat panel displays, liquid crystal displays, and the like. The external display interface 450 is configured as an interface to an external display/printer device 403. The external display/printer device 403 can be a video display device such as a television, a computer monitor, a flat panel display, an image projection system, a virtual-reality headset, a printer, and the like. In one embodiment, the video
20 interface provides a standard analog NTSC (National Television Systems Committee) or Phase Alternating Line (PAL) signal. In one embodiment, the external display interface 450 provides a digital video signal, such as, for example, an MPEG (Motion Picture Experts Group) signal, an HDTV (High Definition Television) signal, etc.

 The display 200 is used to select the images that will be downloaded, to select the
25 images that will be printed, and, optionally, to manipulate a selected image (e.g., crop the image, lighten the image, darken the image, etc.). The user can also use the display 200 to review, organize, and select images that were previously downloaded and stored in the storage module 130.

 Figure 5 is a flowchart that illustrates user interaction with the storage module
30 130. In Figure 5, the user provides digital images stored on an external device such as a flash ram card 502, an E-file cartridge 100, a computer 504, another storage module

(EPA), or other digital storage device. In a process block 505, the user connects the external storage device to the storage module 130. After connecting the external storage device, the storage module 130 is turned on and runs its power-up sequence in a process block 506. The power-up sequence advances to either a “too-cold” warning process block 507, a “low-battery” warning process block 508, or a media input process block 509. The warning process blocks 507 and 508 provide status messages to the user indicating that the storage module cannot be used due to an error condition.

In the media input process block 509, the storage module 130 examines the data stored on the external storage device and begins a download operation. If, in the media input process block 509, the storage module 130 detects that the external storage device is a flash ram card, the process advances to a flash card process block 510; otherwise, the process advances to a download block 511. In the download block 511, digital images from the external storage device are downloaded into the storage module 130 and a “downloading” icon is displayed on the display 200. Once downloading is complete, the process advances to a process block 512 where the downloaded images are stored on the internal mass storage device in the storage module 130. Images can be stored by date and by volume. If the process block 512 detects that the external storage device is an electronic film cartridge 100, then the process advances to an erase block 513, otherwise the process advances to a thumbnail block 516.

In the erase block 513, the memory in the electronic film cartridge is erased and the process advances to a process block 514 where the clock on the electronic film is updated from a clock in the storage module 130. After updating the clock, the process advances to a process block 515 where a “remove” icon is displayed informing the user that it is safe to remove the electronic film device. Upon displaying the “remove” icon, the process advances to the thumbnail process block 516.

In the thumbnail process block 516, a plurality of blank “thumbnail” (i.e., small) images are shown on the display 200 and the process advances to a process block 517. In the process block 517, the downloaded images are processed (i.e. decompressed, dark current corrected, etc.) and as each image is processed, one of the blank thumbnail images is replaced by an actual thumbnail image of one of the downloaded digital images. A moving highlight cursor shows the user which thumbnail is being processed.

When all thumbnail images have been processed the process advances to a process block 518 where the thumbnail images are displayed.

Upon completion of the process block 518, the process advances to a process block 519 where the storage module 130 accepts data manipulation commands from the user via the buttons and user controls 220 on the storage module 130. From the process block 519, the user can advance to a view-full-image block 520, a delete image block 522, or a view/select thumbnail images block 521.

From either the view-full-image block 520 or the view/select thumbnail images block 521, the process advances to data output process block 523. The data output process block 523 provides output of the viewed/selected digital images to a device such as a flash ram card 524, the computer 404, the display 403, the network 441, etc.

The user may also use the storage module 130 in a recall/viewing mode to view images previously stored in the storage module 130. The recall/viewing mode begins at a process block 526 and advances immediately to a process block 527 where the storage module 130 is turned on. After turn-on, and a subsequent warm-up process block 528, the process advances to an icon display process block 529. In the icon display process block 529, icons are shown on the display 200. The storage module 130 allows the user to organize the images into multiple volumes (albums), where each volume is a collection of images. In other words, the physical album 130 can be configured as multiple logical albums. The icons give the user various choices for selecting a volume (or "roll") of images (an, optionally, sound files) previously downloaded (as discussed in connection with Figure 6). The user choices include "select photo volume" and "delete volume." If the user selected the "delete volume, the process advances to a delete process block 531. If the user selects the "select photo volume" the process advances to the process block 518 to display thumbnail images of the pictures in that volume. Thumbnail images are small images sized so that the thumbnail images for several complete pictures can be shown on the display 200 at one time.

Figure 6 is a block diagram that illustrates one embodiment of the logical storage of images in the storage module 130. Figure 6 shows two volumes of images, a first volume 602 and a second volume 603. The first volume 602 contains images 610-614 and, optionally, sound files 630-634. Each sound file is associated with an image,

and the sound files 630-634 are associated with images 610-614 respectively. The second volume 603 contains images 620-623 and, optionally, sound files 641-643.

As described in connection with Figure 5, organizing the images into volumes makes it easier for a user to manage a large number of images, because each volume typically contains only a subset of the total number of images stored in the storage module 130. Images can be arranged in volumes according to date, according to subject, according to size, and by user selection. The user can delete a volume, download an entire volume, add or remove images from a volume, and display a volume. In one embodiment the storage module 130 displays a volume by showing each image in the volume for a period of time and then automatically advancing to the next picture in the volume. When digital sound clips are provided, the sound clip associated with each picture is played while the picture is displayed.

Figure 7A is a data flowchart that illustrates one embodiment of an input/output signal processing sequence used by the storage module 130. Figure 7A begins with a step 710 where image data is loaded from an external source such as the E-film cartridge 100, a computer, the internet, a digital camera, a scanner, and the like. Once the image data is loaded, the data advances to a process block 711 where the image data is stored on the internal storage device 402 and, optionally, displayed on the display 200.

Commands, such as commands from the user, are processed in a process block 714. In response to commands from the process block 714, an image output processing block 713 retrieves images from the internal storage device 402, formats the image data, and sends the image data to a display device such as a printer, the internet, a photo-printer (e.g., a photofinisher that prints an image on photographic print paper), a television, a computer, a cellular telephone with an image display, other media, and the like.

Figure 7B is a flowchart that illustrates one embodiment of a signal processing sequence used by the storage module 130. Figure 7B begins with a step 701 where an image is retrieved from either the internal storage device 402 or the external (removable) storage device 400. After retrieving the image, the image is decompressed in a process block 702 and passed to an image edit block 703. The image edit block 703

can also provide the uncompressed image to the display device 200.

In the image edit block 703 the image can be edited by the user. User edit functions include changing the image color balance, contrast, brightness, size. The user can also crop portions of the image and zoom-in on portions of the image.

5 The image edit block 703 also provides non-user controlled (e.g., automatic) image editing directed by the processor 420. In one embodiment, the processor 420 performs edge detection, gamma correction, and other image processing to enhance the appearance of the image when displayed on the display 200, the external display/printer 403, or the computer 404.

10 Upon completion of the edit block 703, the data is recompressed in a compression block 706. After compression, the process advances to a storage block 706 where the data is stored.

One embodiment of the invention used in connection with an electronic film cartridge 800 is shown in Figure 8. The electronic film cartridge 800 fits within a film cavity of a camera 810, such as a standard 35 mm camera. The electronic film cartridge 800 is shaped so that it can mate with the camera 810 without modifications being made to the camera 810. Placing the electronic film cartridge 800 into the camera 810 effectively turns the camera 810 into a digital camera, offering the user the ability to rapidly switch between conventional and electronic photography, while still providing the user the freedom to use camera attachments and other lenses. This offers the user both simplicity and convenience.

Another view of the electronic film cartridge 800 is shown in Figure 9. The cartridge 800 is advantageously capable of recording quality images with over 1.0 megapixel resolution, and includes a nonvolatile storage (e.g., flash memory) capable of storing many full resolution pictures. The cartridge 800 can be reused many times, resulting in significant savings in film and film development. When it is not in use, the cartridge 800 is preferably stored in a molded carrier, as shown in Figure 13. To load the cartridge 800 into the camera 810, the cartridge 800 is taken out of the carrier and placed into the body of the camera 810 like a conventional roll of film. Once the camera 810 is closed, the user is ready to take pictures. A visible display 910 on the cartridge 800 confirms that the cartridge 800 is ready to record the next picture (within some predetermined time period,

such as a period from about 1 microsecond up to a period of several seconds or more, following the picture just recorded), and this can be confirmed by an audible signal from the cartridge 800. The display 910 also preferably provides a shot counter. In one embodiment, the electronic film cartridge 800 alerts the user with an audible alarm when the system is full. In one embodiment, the photographic speed (ASA) of the electronic film can be 64 or greater.

Figures 10A through 10C show additional views of the electronic film cartridge 800. The cartridge 800 includes a battery (not shown) for powering the electronics. In one embodiment, when the battery power becomes low, the cartridge 800 sounds an audible alarm and fails to illuminate a "ready" indicator on the display 910 to notify the user of the low battery power.

The electronic film cartridge 800 includes an imager 1010 for capturing electronic images. Rather than leaving the imager 1010 and associated circuits of the cartridge 800 on continuously, the imager 1010 and associated circuits are preferably activated electronically to capture an image just as the shutter of the camera 810 opens, so that the life of the battery within the cartridge 800 is extended.

In one embodiment, the ElectroMagnetic Interference (EMI) generated by the electronics of the camera 810 is detected to "awaken" the imager 1010 and associated circuits of the electronic film cartridge 800. For those cameras that do not provide sufficiently strong EMI to make this possible, an attachment to the camera 810 is advantageously provided in the form of a shutter button extension, in which the shutter button generates the necessary EMI to activate the imager 1010 and associated circuits of the electronic film cartridge 800.

In another embodiment, acoustical emissions generated by the mechanical mechanisms of the camera 810 are detected, upon which the imager 1010 and associated circuits of the cartridge 800 are activated. In the embodiment illustrated in Figure 10A, for example, the cartridge 800 includes a detector 1040, such as an analog microphone, that can detect acoustical emissions generated by the mechanical mechanisms of the camera 810 while capturing an image.

The life of the battery within the cartridge 800 can be further extended by turning off the electronic circuitry within the cartridge 800 when it is not located within a camera

810. In the illustrated embodiment, the cartridge 800 includes a contact pressure switch 1020 for sensing the pressure exerted on the cartridge 800 near its electronic film plate. The electronic circuitry of the cartridge 800 can be deactivated when the pressure switch 1020 detects that pressure is not being applied.

5 In one embodiment, data is stored in the nonvolatile flash memory of the cartridge 800 such that the recorded image can be reconstructed even if an entire "block" of adjacent flash memory cells are defective. One technique for accomplishing this relies on replacing corrupted data with an average of values from adjacent image lines, but with adjacent image lines being written into widely separated sections of the memory. This
10 reduces the possibility that successive lines of image data are written into the same "block" of memory. From the software point of view, this can be accomplished by re-ordering the image line count value when establishing the memory addresses such that the unit line count bit is moved to a higher order position, with successive image lines not being stored in the same "block" of memory. Those of ordinary skill in the art will
15 understand that other techniques for storing data in the nonvolatile memory of the cartridge 800 can be employed.

The electronic film cartridge 800 of the illustrated embodiment includes a connector 1030 for transferring electronic images from the cartridge 800 to a computer or other storage device. Once pictures have been recorded with the cartridge 800, they can
20 be downloaded to a computer, such as a personal computer, by connecting the connector 1030 of the cartridge 800 with an adapter cable (not shown) to an input port of the computer. Suitable ports include Small Computer System Interconnect (SCSI) ports, parallel port, serial ports, Universal Serial Bus (USB) ports, Personal Computer Memory Card International Association (PCMCIA) ports, network ports, ethernet ports, Infra-Red
25 (IR) ports, Radio Frequency (RF) ports, FireWire ports, and the like.

Figure 11 is a block diagram showing one embodiment of an electronic film cartridge 800. The cartridge 800 includes a microcontroller 1405 coupled to a PCMCIA II interface 1415, a USB interface 1410, a digital microphone subsystem (microphone) 1420, a display 910, a pressure switch 1020, a nonvolatile memory 1435, and an imaging
30 subsystem 1460. The microphone 1420 comprises a detector 1040 (such as an analog microphone), an anti-aliasing low-pass filter 1425, and an analog-to-digital converter

1430. The display 910 may comprise any suitable digital display, such as a flat panel display, a liquid crystal display, or the like. The nonvolatile memory 1435 may comprise any suitable nonvolatile computer memory, such as flash memory or the like.

5 The imaging subsystem 1460 of the illustrated embodiment comprises a digital signal processor (DSP) 1440, a cache memory 1450, a clock 1445, an analog-to-digital converter 1455, and an imager 1010. The cache memory 1450 may comprise any suitable volatile or nonvolatile memory, such as Random Access Memory (RAM), Dynamic RAM (DRAM), Synchronous Dynamic RAM (SDRAM), flash RAM, or the like. The DSP 1440 is coupled to the microcontroller 1405, the clock 1445 and the cache memory 1450.
10 The clock 1445 is also coupled to the analog-to-digital converter 1455, which is coupled to the imager 1010.

Figure 12 is a flowchart that illustrates the operation of an electronic film cartridge 800 during an image capture sequence. In a first step 1502, the microcontroller 1405 operates in a low-power mode. In an optional step 1504, the microcontroller 1405 polls the pressure switch 1020. In an optional step 1506, the microcontroller 1405 determines
15 whether the pressure switch 1020 is activated, indicating whether the cartridge 800 is located within a camera 810. If the pressure switch 1020 is deactivated, then the microcontroller 1405 returns to the optional step 1504, where it continues to poll the pressure switch 1020. Once the pressure switch 1020 becomes activated, indicating that
20 the cartridge 800 is located within a camera 810, then the microcontroller 1405, in a step 1508, polls the microphone 1420 for a triggering event.

In another embodiment, the electronic circuitry of the cartridge 800 is turned off when the cartridge 800 is not located within a camera 810, as indicated by the pressure switch 1020. In this embodiment, the pressure switch 1020 acts as a power switch that
25 turns on the electronic circuitry of the cartridge 800 when the door of the camera 810 exerts pressure on the pressure switch 1020. When initially turned on, the microprocessor 1405 operates in the low-power mode of step 1502, as described above. In this embodiment, however, the microprocessor 1405 does not poll the pressure switch 1020 as indicated in Figure 12. Rather, when the pressure switch 1020 is activated, the
30 microprocessor 1405 proceeds to step 1508, where it polls the microphone 1420 for a triggering event.

A triggering event may constitute any of a number of acoustical emissions generated by the mechanical mechanisms of the camera 810 during an image capture sequence. For example, a triggering event may constitute a mirror flip up, the pressing of a shutter button, or the like.

5 In a next step 1510, the microcontroller 1405 determines whether the microphone 1420 has detected a triggering event, such as a mirror flip up. If the microcontroller 1405 has not detected a triggering event, then the microcontroller 1405 returns to step 1508, where it continues to poll the microphone 1420. Once the microphone 1420 detects a triggering event, then the microcontroller 1405, in a step 1512, powers up the imaging
10 subsystem 1460 to prepare for the capture of an image.

In a next step 1514, the DSP 1440 activates the imager 1010 to initiate the image capture process. In one embodiment, the image capture process is terminated after a predetermined time period, such as, for example, 1/60 second, 1/30 second, 1/15 second, 1 second, etc. After the predetermined time period has elapsed, the DSP 1440, in a step
15 1520, stores the image captured by the imager 1010 into the cache memory 1450.

In one embodiment, the microphone 1420 can be polled during an optional step 1515 to determine the end of the image capture process. In an optional step 1516, the microcontroller 1405 determines whether the microphone 1420 has detected a triggering event, such as a mirror flip down, shutter close, etc., indicating the end of the image
20 capture process. If the microphone 1420 has not detected a triggering event, then the microcontroller 1405 returns to the optional step 1515, where it continues to poll the microphone 1420. Once the microphone 1420 detects a triggering event, then the DSP 1440, in a step 1520, stores the image captured by the imager 1010 into the cache memory 1450.

25 In a further step 1522, the DSP 1440 resets the imager 1010 and re-activates the imager 1010 to initiate the process for capturing a dark current correction image. After a predetermined time period, the DSP 1440, in a step 1523, deactivates the imager 1010, thus terminating the process for capturing the dark current correction image. In a step 1524, the DSP 1440 stores the dark current correction image in the cache memory 1450.
30 In a step 1526, the DSP 1440 corrects the original image using data in the dark current correction image.

In a following step 1528, the DSP 1440 compresses the corrected image. In a next step 1530, the microcontroller 1405 transfers the compressed image to the nonvolatile memory 1435. The microcontroller 1405 then returns to the step 1502, where it returns to the low-power mode and proceeds to step 1508, where it polls the microphone 1420 to
5 await the next image capture sequence, as described above.

Figures 13A through 13C show one embodiment of a carrier 1100 for housing an electronic film cartridge 800 while the cartridge 800 is not located within a camera 810. In the illustrated embodiment, the carrier 1100 includes a cavity 1110 for accepting the electronic film cartridge 800 and a door 1120, which is configured to enclose the cartridge
10 800. The door 1120 of the carrier 1100 includes a window 1130, which is positioned such that the display 910 of the cartridge 800 is visible through the door 1120 when closed. In one embodiment, the door 1120 of the carrier 1100 does not activate the pressure switch 1020 of the electronic film cartridge 800 when closed. The pressure switch 1020 is accessible by the user when the cartridge 800 is in the carrier 1100. This configuration
15 allows the user to apply pressure to the pressure switch 1020, thus activating the display 910 of the cartridge 800 to indicate the number of images stored in the cartridge.

The carrier 1100 of the illustrated embodiment includes a PCMCIA II connector 1140 and a USB connector 1150 electrically coupled to contacts (not shown) that mate with the connector 1030 of the electronic film cartridge 800. This configuration enables
20 communication between the PCMCIA II interface 1415 or the USB interface 1410 of the cartridge 800 and a PCMCIA port or a USB port of a computer or other storage device. In other embodiments, the carrier 1100 itself can include a computer interface, such as a PCMCIA II interface, a USB interface, or the like, to communicate with a compatible communications port of a computer or other storage device.

Advantageously, the cartridge 800 can be inserted into the carrier 1100 to
25 download pictures to a computer or other storage device. Preferably, the download process takes less than a minute for 30 pictures. Encryption can be used to protect confidentiality of the images. The images can be loaded into a computer for viewing, artistic manipulation, electronic storage, or the printing of custom or standard photoprints
30 using, for example, digital printing methods. To this end, the computer can be provided with compilation and storage software. (Alternatively, the images can be viewed on a

television screen or downloaded directly to a photo printer.)

As an alternative to downloading images to a computer, images recorded on an electronic film cartridge 800 can be transmitted electronically over the Internet using a storage module 1200, as shown in Figures 14 through 16.

5 Figures 14A and 14B show one embodiment of a storage module 1200 for storage or transmission of images recorded on an electronic film cartridge 800. In the illustrated embodiment, the storage module 1200 has a cavity 1210 for accepting an electronic film cartridge 800 and a door 1220, which is configured to enclose the cartridge 800. As illustrated in Figure 14A, the cartridge 800 can include electrical contacts 1230 (e.g., gold
10 plated) that mate with electrical contacts 1240 in the storage module 1200 when the cartridge 800 is properly inserted into the storage module 1200. The electrical contacts 1240 are connected to a processor 1250 within the storage module 1200, with at least one battery 1260 supplying power to the electronics within the storage module 1200. The processor 1250 can advantageously transmit images recorded on the cartridge 800 via a
15 phone jack 1270 (e.g., an RJ-11 jack).

In one embodiment, the storage module 1200 stores many pictures which can be displayed on an optional screen (image display) 1280, as illustrated in Figure 14B. Using control buttons or knobs 1290, pictures within the memory of the processor 1250 can be selected for viewing. In one embodiment, the storage module 1200 functions as a photo
20 album, and the memory within the storage module 1200 can be advantageously partitioned into several directories (e.g., multiple albums). With the provided download software, the user has the option of selecting one of a number of industry standard formats for the images: JPEG, FLASHPIX, BMP, etc. The storage module 1200 preferably further comprises a set of LEDs 1295 that indicate the status of the electronic processing, as
25 described in greater detail below in connection with Figure 29. In one embodiment, the storage module 1200 is approximately 4 inches wide, 2.7 inches long and 1 inch thick, and can optionally include a flash card (not shown) onto which images can be downloaded.

Figure 15 shows a block diagram of the storage module 1200 in communication with a memory card 1910, a PC card 1920, and a carrier 1100 housing an electronic film cartridge 800. As illustrated, the storage module 1200 comprises an image display 1280, a
30 function display 1930, a control button 1290, a phone jack 1270, and a USB interface

1940.

Figures 16A and 16B show another embodiment of the storage module 1200. In the embodiment illustrated in Figures 16A and 16B, the storage module 1200 includes a memory card interface 2010 configured to communicate with the memory card 1910 and a
5 PCMCIA II port 1310 configured to communicate with the PCMCIA II connector 1140 of the carrier 1100 and the PC card 1920. The storage module 1200 of the illustrated embodiment also includes an optional phone jack 1270, a USB interface 1940, an image display 1280, a function display 1930, and a set of control buttons or knobs 1290.

Figure 17 is a block diagram that shows the functional relationships between the
10 components of one embodiment of an electronic film system. The electronic film cartridge 800 comprises electronic film 1600 containing images that are downloaded electronically through an interface 1610 to a central processing unit (CPU) 1620. The CPU 1620 is in communication with a memory 1630. In some embodiments, the CPU 1620 is also, optionally, in communication with a display screen 1280, a video interface
15 1650, and/or a computer interface 1660. The CPU 1620 is preferably further linked to a modem 1640 through which data, including pictures, can be downloaded to a communications network 1670.

The communication network 1670 may comprise, for example, the Internet, an intranet, a Public Switched Telephone Network (PSTN), an Integrated Services Digital
20 Network (ISDN), a cellular telephone network (including analog and digital systems), a satellite communications network (including, for example, the Iridium system), and the like. Together, the interface 1610, the CPU 1620, the memory 1630, and the modem 1640, form part of the processor 1250 shown in Figure 14. The display 1280 may comprise, for example, a flat panel display, a liquid crystal display, or the like. The video
25 interface 1650 can be configured as an interface to a video display device such as a television, a computer monitor, a flat panel display, an image projection system, or the like. In one embodiment, the video interface provides a standard analog NTSC (National Television Systems Committee) signal. In one embodiment, the video interface provides a digital television signal, such as, for example, an MPEG (Motion Picture Experts Group)
30 signal, an HDTV (High Definition Television) signal, etc.

Figure 18 is a block diagram that shows the functional relationships between the

components of one embodiment of an electronic film system. As illustrated, the system includes a storage module 1200 configured to communicate with a computer 2110, a communication network 1670, a memory card 1910, a PC card 1920, and a carrier 1100 housing an electronic film cartridge 800. The storage module 1200 of the illustrated
5 embodiment comprises a processor 1250 coupled to an image display 1280, a function display 1930, a phone jack 1270, a USB interface 1940, a PCMCIA II interface 1310, a memory interface 2010, and a user control 1290. The storage module 1200 can download and store a plurality of images recorded on the cartridge 800. Alternatively, the storage module 1200 can transfer the images to the computer 2110 or transmit the images to a
10 remote location via the communication network 1670.

Figure 19 is a flowchart that illustrates the operation of one embodiment of the storage module 1200. In a first step 2200, a user inserts the carrier 1100 housing the electronic film cartridge 800 into the storage module 1200. In a next step 2205, the user presses a storage module on/off button. In an optional step 2210, the user can insert the
15 memory card 1910 into the storage module 1200, if desired. In a step 2215, the user selects the destination for the images recorded on the cartridge 800, such as the memory card 1910 (if inserted) or the PC card 1920.

In a next step 2220, the storage module 1200 begins to download the images to the selected destination. In a step 2225, the function display 1930 of the storage module 1200 preferably displays a message apprising the user of the download progress and, if the
20 images are being downloaded to the memory card 1910, warning the user not to remove the memory card 1910 during the download process. In a step 2230, the storage module 1200 determines whether the download process has been completed. If not, then the storage module 1200 continues to download images from the cartridge 800. Once the
25 download process is completed, then the storage module 1200, in a step 2235, clears the nonvolatile memory 1435 of the cartridge 800. In a next step 2240, the function display 1930 of the storage preferably displays a message informing the user that the download process is complete and that the nonvolatile memory 1435 of the cartridge 800 has been cleared.

30 In a step 2245, the storage module 1200 determines whether the user has input a menu toggle command via the user control 1290. If so, then the function display 1930 of

the storage module 1200, in a step 2250, displays the next menu option to the user. In a preferred embodiment, the main menu of the storage module 1200 comprises the following menu options:

- “Review/Select Images”
- 5 “Slide Show from Memory Card”
- “Send Images to Host/Memory Card”
- “Upload Images to Memory Card from Host”
- “Delete All Images”
- “Send Images to Internet”

10 If, during step 2245, the storage module 1200 determines that the user has not input a menu toggle command, then, in a next step 2255, the storage module 1200 determines whether the user has input a power off command via the user control 1290. If so, then the storage module 1200, in a final step 2260, ends processing. Otherwise, processing returns to the step 2245, where the storage module 1200 determines whether
15 the user has input a menu toggle command via the user control 1290.

Figure 20 is a flowchart that illustrates the operation of the storage module 1200 when, in a first step 2300, the user selects the “Review/Select Images” menu option. In an optional step 2305, the user can insert the memory card 1910 into the storage module 1200, if desired. In a next step 2310, the user activates the image display 1280 of the
20 storage module 1200. In a further step 2315, the user selects a viewing format for displaying the images on the image display 1280.

In a step 2320, the user can select an image to rotate or delete using the user control 1290. In a following step 2325, the function display 1930 of the storage module 1200 asks whether the user desires to rotate the selected image. In a step 2330, the storage
25 module 1200 determines whether the user chooses to rotate the selected image. If so, then, in a next step 2335, the storage module 1200 determines whether the user wishes to rotate image clockwise or counterclockwise. If the user wishes to rotate image clockwise, then the storage module 1200, in a step 2340, rotates the image clockwise. If, on the other hand, the user wishes to rotate image counterclockwise, then the storage module 1200, in a
30 step 2345, rotates the image counterclockwise. Processing then continues to a step 2365, which is described in more detail below.

If, during step 2330, the storage module 1200 determines that the user does not desire to rotate the selected image, then the function display 1930 of the storage module 1200, in a next step 2350, asks whether the user desires to delete the selected image. In a following step 2355, the storage module 1200 determines whether the user chooses to delete the selected image. If so, then the storage module 1200, in a step 2360, deletes the selected image from the image source on which it is stored. Otherwise, processing continues to the step 2365, where the storage module 1200 determines whether the user chooses to return to the main menu. If so, then the storage module 1200, in a step 2370, returns to the main menu of the storage module 1200. Otherwise, processing returns to the step 2320, where the user can select another image to rotate or delete using the user control 1290.

Figure 21 is a flowchart that illustrates the operation of the storage module 1200 when, in a first step 2400, the user selects the "Slide Show from Memory Card" menu option. In a step 2405, the user selects a display for viewing the slide show, such as the image display 1280 of the storage module 1200 or a digital projector. In a next step 2410, the user inserts the image source, such as the memory card 1910 or the PC card 1920, into the storage module 1200.

In a next step 2415, the storage module 1200 determines whether the user chooses to manually or automatically advance the images displayed during the slide show. If the user chooses to manually advance the images, then the storage module 1200, in a next step 2420, displays the first image in the slide show. In a following step 2425, the storage module 1200 determines whether the user has provided an input, indicating a desire to advance to the next image. If the user has not provided any input, then the storage module 1200 continues to display the current image. Once the user provides an input, then the storage module 1200 determines whether any more images remain to be displayed in the slide show. If so, then processing returns to step 2420, where the storage module 1200 displays the next image in the slide show. If no more images remain, however, then the function display 1930 of the storage module 1200, in a step 2435, asks the user whether to repeat the slide show.

If, during step 2415, the user chooses to automatically advance the images, then, in a next step 2440, the user selects the delay time between the advancement of successive

images in the slide show. In a preferred embodiment, the user can choose a delay time in the range of about 3 seconds to about 15 seconds, more preferably in the range of about 5 seconds to 10 seconds. In a next step 2445, the storage module 1200 displays the first image in the slide show. In a further step 2450, the storage module 1200 determines
5 whether the delay time has elapsed. If not, then the storage module 1200 continues to display the current image. Once the delay time elapses, then the storage module 1200, in a step 2455 determines whether any more images remain to be displayed in the slide show. If so, then processing returns to step 2445, where the storage module 1200 displays the next image in the slide show. If no more images remain, however, then processing
10 continues to the step 2435, where the function display 1930 of the storage module 1200 asks the user whether to repeat the slide show.

In a next step 2460, the storage module 1200 determines whether the user wishes to repeat the slide show. If so, then processing returns to the step 2415, where the storage module 1200 determines whether the user chooses to manually or automatically advance
15 the images displayed during the slide show, as described above. On the other hand, if the user does not wish to repeat the slide show, then the storage module 1200, in a step 2465 returns to the main menu of the storage module 1200.

Figure 22 is a flowchart that illustrates the operation of the storage module 1200 when, in a first step 2500, the user selects the "Send Images to Host/Memory Card" menu
20 option. In a step 2505, the user inserts the image source, such as the memory card 1910 or the PC card 1920, into the storage module 1200. In a next step 2510, the user chooses the destination for the images to be transferred. In a preferred embodiment, the user can choose another memory card 1910 or the computer 2110 as the destination for the images to be transferred.

If the user selects the memory card 1910 as the destination, then the function display 1930 of the storage module 1200, in a next step 2515, asks the user whether to send all the images from the image source to the memory card 1910. If the user does not
25 wish to send all the images, then the user, in a step 2520, selects the images the user wishes to send. In a next step 2525, the user inserts the destination memory card 1910
30 into the storage module 1200. If, during step 2515, the user chooses to send all the images from the image source, then processing continues directly to the step 2525, where the user

inserts the destination memory card 1910 into the storage module 1200, as described above.

In a step 2530, the storage module 1200 begins to transfer the images from the image source to the destination memory card 1910. In a next step 2535, the function display 1930 of the storage module 1200 preferably displays a message warning the user not to remove the destination memory card 1910 during the transfer. In a further step 2540, the storage module 1200 determines whether the image transfer is complete. If not, then the storage module 1200 continues to transfer the images from the image source to the destination memory card 1910. Once the image transfer is complete, then the function display 1930 the storage module 1200, in a step 2545, asks the user whether to perform another image transfer.

If, during step 2510, the user selects the computer 2110 as the destination, then the function display 1930 of the storage module 1200, in a next step 2550, asks the user whether to send all the images from the image source to the computer 2110. If the user does not wish to send all the images, then the user, in a step 2555, selects the images the user wishes to send. In a next step 2560, the user connects the USB interface 1940 of the storage module 1200 to a USB port on the computer 2110. If, during step 2550, the user chooses to send all the images from the image source, then processing continues directly to the step 2560, where the user connects the USB interface 1940 of the storage module 1200 to a USB port on the computer 2110, as described above.

In a step 2565, the storage module 1200 begins to transfer the images from the image source to the computer 2110 via the USB connection. In a next step 2570, the storage module 1200 determines whether the image transfer process is complete. If not, then the storage module 1200 continues to transfer the images from the image source to the computer 2110. Once the image transfer is complete, then the function display 1930 the storage module 1200, in a step 2575, preferably displays a message directing the user to launch an image manager software application on the computer 2110. Processing then continues to the step 2545, where the function display 1930 the storage module 1200 asks the user whether to perform another image transfer, as described above.

If the user wishes to perform another image transfer, then processing returns to the step 2510, where the user chooses the destination for the images to be transferred, as

described above. If the user does not wish to perform another image transfer, then the storage module 1200, in a step 2580 returns to the main menu of the storage module 1200.

Figure 23 is a flowchart that illustrates the operation of the storage module 1200 when, in a first step 2600, the user selects the "Upload Images to Memory Card from Host" menu option. In a step 2605, the user connects the USB interface 1940 of the storage module 1200 to a USB port on the computer 2110. In another step 2610, the user inserts the memory card 1910 into the storage module 1200. In a next step 2615, the function display 1930 of the storage module 1200 preferably displays a message directing the user to launch an image manager software application on the computer 2110. In a preferred embodiment, the user follows the steps directed by the image manager software application to transfer images from the computer 2110 to the memory card 1910.

In a next step 2620, the storage module 1200 begins to transfer images from the computer 2110 to the memory card 1910. In a step 2625, the function display 1930 of the storage module 1200 preferably displays a message warning the user not to remove the memory card 1910 during the transfer. In a further step 2630, the storage module 1200 determines whether the image transfer process is complete. If not, then the storage module 1200 continues to transfer the images from the computer 2110 to the memory card 1910. Once the image transfer process is complete, then the storage module 1200, in a step 2635, returns to the main menu of the storage module 1200.

Figure 24 is a flowchart that illustrates the operation of the storage module 1200 when, in a first step 2700, the user selects the "Delete All Images" menu option. In a step 2705, the user inserts an image source, such as the memory card 1910 or the PC card 1920, into the storage module 1200. In a next step 2710, the user selects the image source from which to delete all the images. In a next step 2715, the function display 1930 of the storage module 1200 asks the user whether to delete all the images from the image source.

In a step 2720, the storage module 1200 determines whether the user chooses to delete all the images. If so, then the function display 1930 of the storage module 1200, in a step 2725, preferably requests confirmation from the user. In a step 2730, the storage module 1200 determines whether the user provides confirmation. If the user provides confirmation, then the storage module 1200, in a step 2735, deletes all the images from the image source. In a next step 2740, the storage module 1200 returns to the main menu of

the storage module 1200.

If, during the step 2720, the user chooses not to delete all the images or if, during the step 2730, the user fails to provide confirmation, then processing continues to the step 2740, where the storage module 1200 returns to the main menu of the storage module 1200 without deleting all of the images from the image source.

Figure 25 is a block diagram that shows the functional relationships between the components of one embodiment of an electronic film system. The system includes a communication network 1670 coupled to a storage module 1200, a central server 3000, a local access provider 3010, a plurality of local access accounts 3020, and a plurality of image processor servers 3030. The storage module 1200 is configured to communicate with the central server 3000 and with the image processor servers 3030 via the communication network 1670. Furthermore, the storage module 1200 is configured to gain access to the communication network 1670 via the local access provider 3010 or via one of the local access accounts 3020.

In one embodiment, the communication network 1670 includes the Internet, which is a global network of computers. The structure of the Internet, which is well known to those of ordinary skill in the art, includes a network backbone with networks branching from the backbone. These branches, in turn, have networks branching from them, and so on. Routers move information packets between network levels, and then from network to network, until the packet reaches the neighborhood of its destination. From the destination, the destination network's host directs the information packet to the appropriate terminal, or node. For a more detailed description of the structure and operation of the Internet, please refer to "The Internet Complete Reference," by Harley Hahn and Rick Stout, published by McGraw-Hill, 1994.

In one advantageous embodiment, the Internet routing hubs comprise domain name system (DNS) servers, as is well known in the art. DNS is a Transfer Control Protocol/Internet protocol (TCP/IP) service that is called upon to translate domain names to and from Internet Protocol (IP) addresses. The routing hubs connect to one or more other routing hubs via high speed communication links.

One of ordinary skill in the art, however, will recognize that a wide range of communication networks can be employed in the present invention. For example, the

communication network 1670 can include interactive television networks, telephone networks, wireless data transmission systems, two-way cable systems, customized computer networks, interactive kiosk networks, automatic teller machine networks, and the like.

5 In addition to the Internet, the communication network 1670 may also contain Internet access providers. An Internet access provider is a computer system that provides Internet access to consumers. Examples of Internet access providers include American Online, the Microsoft Network, Prodigy, Compuserve, and Network Intensive to name a few. Many users pay monthly access fees to the Internet access providers because the
10 Internet access providers provide local telephone connections, a variety of help services and an organized format for accessing the Internet.

One popular part of the Internet is the World Wide Web. The World Wide Web contains different computers which store HTML documents capable of displaying graphical and textual information. The content provider computers which provide
15 information on the World Wide Web are typically called "web sites." A web site is defined by an Internet address which has an associated electronic page. Generally, an electronic page is a document which organizes the presentation of text, graphical images, audio and video.

In one embodiment, the central server 3000 is a web site on the World Wide Web.
20 Preferably, the central server 3000 is a conventional computer which is equipped with a communications link to the Internet. Preferably, the content provider computer runs an appropriate operating system such as Unix, Microsoft® Windows® 3.1, Microsoft® Windows 95, Microsoft® Windows® NT, the Apple® MacOS® or IBM® OS/2® operating system. As is conventional, the preferred operating system includes a TCP/IP
25 stack which handles all incoming and outgoing message traffic passed over the Internet.

The central server 3000 can, however, include a wide range of devices which provide information, graphics or text. These devices may contain specialized operating systems which communicate using their respective communications protocols. For example, the central server 3000 can include, network servers, video delivery systems,
30 audio-visual media providers, television programming providers, telephone switching networks, wireless communication centers and the like.

In one embodiment, the central server 3000 delivers information to the consumers by utilizing a variety of operational modules. These modules include a content server module, a registration module, and one or more electronic pages.

5 The preferred content server module is a standard Web server software system which serves electronic pages. The content server module may be, for example, Netscape's Internet Server software, Microsoft's Internet Server software or the like. Such server software is configured to process messages from consumer computers and display desired electronic pages. In particular, the server software sends copies of HTML pages to each consumer computer which accesses the central server 3000.

10 The electronic page module within the central server 3000 provides an organizational structure for presenting information to the consumer in the form of an electronic page. In the preferred embodiment, the electronic pages are HTML documents which contain HTML encoding.

15 HTML encoding is a script encoding language which is used to define document content information. As is well known in the art, HTML is a set of conventions for marking portions of a document so that, when accessed by a browser, each portion appears with a distinctive format. The HTML indicates, or "tags," portions of the document (e.g., the title, header, body text, etc.).

20 The registration module allows customers to register with the central server 3000. In the preferred embodiment, the registration module is an enhancement to a standard Web server. This enhanced functionality is preferably implemented with the central server scripts or alternatively, is integrated with the server software. For example, the enhancements can be integrated as application programming interfaces which are combined with the Netscape Server Application Programming Interface (NSAPI) or the
25 Microsoft Internet Server Application Program Interface (ISAPI).

30 When a consumer first accesses the central server 3000, the registration module displays registration information. In particular, the server software displays copies of HTML pages to each consumer which desires to register with the central server 3000. Thus, when a consumer registers with the central server 3000, the registration module displays a HTML document which prompts the consumer to enter demographic data. Once the consumer enters the demographic data, the registration module stores the

demographic data as a profile in a lookup table.

Preferably, the lookup table is implemented with Structured Query Language (SQL) code. The structured query language is a language standardized by the International Standards Organization (ISO) for defining, updating and querying relational databases. For example, the lookup table can be implemented with any number of commercial database programs including Microsoft® Access, Oracle's relational database products and the like.

Figure 26 is a flowchart that illustrates the operation of the storage module 1200 when, in a first step 2800, the user selects the "Send Images to Internet" menu option. In a step 2805, the user inserts an image source, such as the memory card 1910 or the PC card 1920, into the storage module 1200. In a next step 2810, the function display 1930 of the storage module 1200 asks the user whether to transmit all of the images from the image source over the communication network 1670. If the user does not wish to transmit all of the images, then the user, in a step 2815, selects the images the user wishes to transmit. In a next step 2820, the user connects the storage module 1200 to the communication network 1670 via the phone jack 1270. If, during step 2810, the user chooses to transmit all of the images from the image source, then processing continues directly to the step 2820, where the user connects the storage module 1200 to the communication network 1670, as described above.

In a next step 2825, the storage module 1200 dials the central server 3000 coupled to the communication network 1670. In one embodiment, the central server 3000 has a toll-free telephone number. The operation of the central server 3000 upon receipt of this call is described in more detail below with respect to Figure 27. In one embodiment, the central server 3000 determines the location of the storage module 1200 and, in a step 2830, provides information to the storage module 1200 regarding a local access provider 3010 having a local access telephone number based on the location of the storage module 1200. In a step 2835, the storage module 1200 uses the information provided by the central server 3000 to dial the local access provider 3010 and gain access to the communication network 1670.

In a next step 2840, the storage module 1200 begins transmitting the selected images to one of the image processor servers 3030 coupled to the communication network

1670. In one embodiment, the user can select a preferred image processor server 3030 to receive the transmitted images. In one embodiment, the central server 3000 can select an appropriate image processor server 3030 to receive the transmitted images based on predetermined criteria, such as the user's photographic equipment or the location of the storage module 1200. In one embodiment, the image processor server 3030 is a business partner of the administrator of the central server 3000.

When the image processor server 3030 receives the transmitted images, the image processor server 3030 can perform a variety of functions. For example, in one embodiment, the image processor server 3030 can print out the transmitted images on photo-quality paper and send the printed pictures to a predetermined address, such as the user's home address. In another embodiment, for example, the image processor server 3030 can display the transmitted images on a predetermined web site.

In a step 2845, the function display 1930 of the storage module 1200 preferably displays a message warning the user not to disconnect the phone jack 1270 during the transmission of the images. In a next step 2850, the storage module 1200 determines whether the image transmission process is complete. If not, then the storage module 1200 continues to transmit images to the image processor server 3030 over the communication network 1670. Once the image transmission process is complete, then the function display 1930 the storage module 1200, in a step 2855, preferably displays a message informing the user that the transmission was successful. In a further step 2860, the storage module 1200 returns to the main menu of the storage module 1200.

Figure 27 is a flowchart that illustrates the operation of the central server 3000 during the transmission of images over the communication network 1670. In a first step 2900, the central server 3000 receives a call from the storage module 1200. In a next step 2905, the central server 3000 identifies the location of the storage module 1200. In one embodiment, the central server 3000 identifies the location of the storage module 1200 by using an analog network interface (ANI) to determine the phone number from which the storage module 1200 is placing the call. In one embodiment, the central server 3000 identifies the locations of the storage module 1200 by accessing an electronic address from which the storage module is communicating with the central server 3000.

In a further step 2910, the storage module 1200 transmits a unique unit identifier

to the central server 3000. Preferably, the storage module 1200 uses appropriate security protocols when communicating with the central server 3000 to ensure the privacy of the information exchanged between the storage module 1200 and the central server 3000.

5 In one embodiment, the central server 3000 maintains a lookup table containing information regarding a plurality of storage modules 1200 and their users. In one embodiment, for example, the lookup table includes a plurality of entries with the following fields: storage module unit identifier, user name, user address, user Internet Service Provider (ISP), user ISP proprietary information (e.g., user name and password), user photographic equipment, and preferred image processor server 3030. In 10 a step 2915, the central server 3000 accesses the lookup table to identify the user of the storage module 1200 and gain access to the information about the user contained in the lookup table.

In one embodiment, the central server 3000, in a step 2920, refers to the location 15 of the storage module 1200, the unique storage module unit identifier, and the information in the lookup table to determine whether the user of the storage module 1200 is affiliated with a local access provider 3010 (i.e., an ISP having a local access telephone number based on the location of the storage module 1200). If so, then the central server 3000, in a step 2925, determines the local access telephone number for the 20 local access provider 3010. In a next step 2930, the central server 3000 provides the local access telephone number and, optionally, the user's ISP proprietary information (e.g., user name and password) to the storage module 1200. As described above with respect to Figure 26, the storage module 1200 can then dial the local access provider 3010 to gain access to the communication network 1670. In a next step 2960, the 25 storage module 1200 terminates the call with the central server 3000.

As an example, a user named John Doe resides in California and owns an account with a national ISP, such as America Online™ (AOL). John Doe purchases an electronic film system, including an electronic film cartridge 800 and a storage module 1200, for which the unique unit number is 12345. Shortly after purchasing the 30 electronic film system, John Doe registers with the central server 3000 by accessing a web site hosted by the central server 300 using an Internet browser on his home

computer, for example. During the registration process, John Doe provides his name, his home address, his ISP affiliation (AOL), and his proprietary ISP account information, such as his user name and password. The central server 3000 associates this information with the unique storage module unit identifier purchased by John Doe
5 (unit number 12345) and stores the information in a lookup table.

While on vacation in Florida, John Doe records images on the cartridge 800. From his hotel room in Florida, John Doe uses the phone jack 1270 of the storage module 1200 to establish a connection with the central server 3000 via the communication network 1670. The central server 3000 determines that the storage
10 module 1200 is calling from Florida and identifies the storage module 1200 as unit number 12345, which belongs to John Doe. The central server 3000 then accesses the lookup table and determines that John Doe owns an ISP account with AOL, which has a local access telephone number for John Doe's location in Florida. The central server 3000 determines the AOL local access telephone number for John Doe's location in
15 Florida and provides the local access telephone number to the storage module 1200, together with John Doe's AOL user name and password.

The storage module 1200 then terminates the connection with the central server 3000. Using the local access telephone number, user name, and password provided by the central server 3000, the storage module 1200 dials AOL to establish a connection
20 with the communication network 1670. The storage module 1200 then transmits the recorded images to an image processor server 3030 over the communication network 1670. As described above, the image processor server 3030 can perform various functions when the images are received. For example, the image processor server 3030 may print out the images on photo-quality paper and mail the printed pictures to John
25 Doe's home address in California.

In one embodiment, the administrator of the central server 3000 maintains a plurality of local access accounts 3020 (i.e., ISP accounts having local access telephone numbers at a plurality of predetermined locations). If, during step 2920, the central server 3000 determines that the user is not affiliated with a local access provider 3010
30 having a local access telephone number (based on the location of the storage module 1200), then the central server 3000 accesses a list of available local access accounts

3020 from among the plurality of local access accounts 3020 maintained by the administrator of the central server 3000. In a step 2935, the central server 3000 temporarily assigns an available local access account 3020 to the storage module 1200. In one embodiment, the central server 3000 may not perform the step 2920. Rather, the
5 central server 3000 may temporarily assign an available local access account 3020 to all users, even if they are affiliated with a local access provider 3010.

In a next step 2940, the central server 3000 removes the assigned local access account 3020 from the list of available local access accounts 3020. In a further step 2945, the central server 3000 provides the local access telephone number and,
10 optionally, the proprietary information for the assigned local access account 3020 to the storage module 1200. As described above with respect to Figure 26, the storage module 1200 can then gain access to the communication network 1670 using the assigned local access account 3020.

In a step 2950, the central server 3000 determines whether the storage module 1200 is still using the assigned local access account 3020. In one embodiment, for example, the ISP of the assigned local access account 3020 can notify the central server 3000 by e-mail when the storage module 1200 has terminated its connection with the communication network 1670 through the assigned local access account 3020. Once
15 the central server 3000 receives notification that the assigned local access account 3020 has become available, then the central server 3000, in a step 2955, returns the assigned local access account 3020 to the list of available local access accounts 3020.

In one embodiment, the central server 3000 includes a timeout feature, which returns the assigned local access account 3020 to the list of available local access accounts 3020 after the lapse of some predetermined time period, even if the central
25 server 3000 has not received notification that the assigned local access account 3020 has become available. Those of ordinary skill in the art will understand that any suitable predetermined time period may be used, such as, for example, a time period in the range of about 10 minutes to about 50 minutes, more preferably in the range of about 20 minutes to about 40 minutes, still more preferably a time period of about 30 minutes. In
30 a final step 2960, the central server 3000 ends the process.

As an example, a user named Jane Doe resides in Texas and owns an account

with a local Texas ISP, the XYZ Company. Jane Doe purchases an electronic film system, including an electronic film cartridge 800 and a storage module 1200, for which the unique unit number is 67890. Shortly after purchasing the electronic film system, Jane Doe registers with the central server 3000 by accessing a web site hosted by the central server 300 using an Internet browser on her home computer. During the registration process, Jane Doe provides her name, her home address, her ISP affiliation (XYZ), and her proprietary ISP account information, such as her user name and password. The central server 3000 associates this information with the unique storage module unit identifier purchased by Jane Doe (unit number 67890) and stores the information in a lookup table.

While on vacation in New York, Jane Doe records images on the cartridge 800. From her hotel room in New York, Jane Doe uses the phone jack 1270 of the storage module 1200 to establish a connection with the central server 3000 via the communication network 1670. The central server 3000 determines that the storage module 1200 is calling from New York and identifies the storage module 1200 as unit number 67890, which belongs to Jane Doe. The central server 3000 then accesses the lookup table and determines that although Jane Doe owns an ISP account with XYZ, that particular ISP does not have a local access telephone number for Jane Doe's location in New York.

However, the administrator of the central server 3000 owns a plurality of ISP accounts having local access telephone numbers for Jane Doe's location in New York. The central server 3000 accesses the list of available ISP accounts owned by the administrator of the central server 3000 which have a local access telephone number for Jane Doe's location in New York. The central server 3000 then temporarily assigns an available account to Jane Doe, such as an ISP account with the ABC Company, a local New York ISP. The central server 3000 determines the ABC local access telephone number for Jane Doe's location in New York and provides the local access telephone number to the storage module 1200, together with the user name and password for the assigned ABC ISP account.

The storage module 1200 then terminates the connection with the central server 3000. Using the local access telephone number, user name, and password provided by

the central server 3000, the storage module 1200 dials ABC to establish a connection with the communication network 1670. The storage module 1200 then transmits the recorded images to an image processor server 3030 over the communication network 1670.

5 Once the image transmission process is complete, the storage module 1200 terminates the connection with the communication network 1670. ABC then sends an e-mail message to the administrator of the central server 3000 notifying the administrator that the temporarily assigned ISP account has become available. When the central server 3000 receives this notification, the central server 3000 returns the
10 temporarily assigned ISP account to the list of available ISP accounts.

As described above, the image processor server 3030 can perform various functions when the images are received. For example, the image processor server 3030 may display the transmitted images on a predetermined web site.

The embodiment of the electronic film system described above has a number of
15 advantages. For example, users with little technical expertise can operate the system effectively. In addition, the system can transmit and process images from a wide variety of locations quickly and easily. Furthermore, the system is configured to conserve money by facilitating a connection to the communication network 1670 using a local telephone access number, even for users without a local access provider 3010. Moreover, users can
20 select from a wide variety of photo processing options quickly and easily.

Figure 28 shows a method of recording and developing pictures in accordance with the present invention. In a first step 1700, images are captured and recorded on an electronic film cartridge 800. In a next step 1702, the images are downloaded to a storage
25 module 1200. In a step 1704, the user decides where to place a call to transmit the images. For example, the user can, in a step 1706, dial a home computer or another personal computer for the purpose of transmitting the images from the storage module 1200. If the user chooses this option in step 1704, then, in a next step 1708, the pictures are printed
out.

Alternatively, the user, in a step 1710, can choose to dial an electronic film service
30 provider for the purpose of transmitting the images from the storage module 1200. The images are transported to the processor facility by electronic means rather than via

physical transport. In a next step 1712, the electronic film service provider performs photofinishing services. In a next step 1714, the pictures can be delivered to the user (e.g., via overnight courier) or to others that the user specifies on a mailing list.

Figure 29 shows another method of recording and developing pictures in accordance with the present invention. In a first step 1800, the user records pictures with an electronic film cartridge 800, while optionally recording the temperature of the cartridge at the time each picture is recorded. Recording the temperature can be used in establishing the dark current at the time each picture is taken, thereby allowing pictures with true color contrast and brightness to be printed out later.

As an alternative to determining the dark current by measuring the temperature, the dark current can be established directly by including in the camera 810 one or more additional detectors (not shown) that are covered with, for example, aluminum, so that these additional "dark" detectors record the dark current level when the shutter is open. These additional detectors can be advantageously formed from the same detector used to electronically record the images. One approach is to record the dark current registered by the "dark" detectors at both the beginning and the end of the imager read-out cycle, with the active image recording detectors being read out in between. It is then possible to interpolate based on the readout time, which is substantial compared to the exposure time (300 ms vs. 5 ms, for instance), using the dark current readings at the beginning and the end of the read-out cycle. Further correction can advantageously be made for the "leakiness" of individual detectors based on a table of values established during unit calibration.

In another embodiment, dark current correction is performed by recording a dark current correction image before or after the capture of a picture image. The picture image can then be corrected using data in the dark current correction image.

In a next step 1802, images stored on the electronic film cartridge 800 are downloaded to a storage module 1200. In a further step 1804, the storage module 1200 retrieves an electronic calibration stored in the electronic film cartridge 800, so that irregularities in the pictures arising from bad pixels, variations in light sensitivity from pixel to pixel, and dark current effects can be corrected. (Alternatively, the calibration can be performed at the EFSP described below).

In a next step 1806, the storage module 1200, using the electronic calibration, constructs a calibrated image for each picture that is closer to a true representation of the photographed object recorded electronically with the camera 810. In a following step 1808, the storage module 1200 analyzes how to most compactly compress the electronic images given the compression algorithms at its disposal, i.e., those which are loaded
5 within the processor 1250. In a step 1810, the algorithm yielding the best, i.e., most compact, image is then selected. In a next step 1812, the electronic images are compressed using that algorithm. The selected algorithm preferably reduces a 2.6 MB (megabyte) file to 1600 kB (kilobyte) or even 1280 kB.

10 In a next step 1814, the images can be advantageously encrypted to ensure confidentiality before they are downloaded over a communications network 1670. Preferably, the images can be downloaded relatively quickly, with a 1280 kB image being downloaded in less than a minute.

Upon instructions from a user, (e.g., by pressing a "send" button) the storage
15 module 1200, in a step 1816, places a telephone call (known as an autocal) to a remote Electronic Film Service Provider (EFSP) and preferably enables caller ID. In a next step 1818, a personal ID unique to the user's storage module 1200 is also transmitted to the remote EFSP. The autocal itself can advantageously be to a toll-free number and can be directed to the EFSP or to an Internet Service Provider, and can, in principle, be made
20 from any location in the world.

The EFSP obtains the user's phone number through caller ID. In a next step 1820, the EFSP, with the user's originating phone number in hand, determines the local date and time at the user's location (taking into account any differences in time zones). In a further step 1822, the user's account records with the EFSP are accessed in view of the user's
25 personal ID. The EFSP instructs the storage module 1200 to download the image data to a desired Internet destination. The destination will typically correspond to an Internet site provided by a print server. Downloading the image data directly to the desired destination (as opposed to downloading the image data to the EFSP and then having the EFSP forward the image data to a desired destination), reduces the amount of data that is
30 handled by the EFSP. For example, in a step 1824, the Internet address of the picture printing station ("print server") closest to the user's mailing address can be selected

because the account records can advantageously include the user's mailing address.

In a next step 1826, the images are downloaded to the specified Internet address, which can be an FTP or FTP-like transfer, along with a corresponding time and date stamp for electronic processing at the print server. In a step 1828, the print server deciphers and decompresses the images. In a further step 1830, the print server verifies that the
5 download has been successful.

In a next step 1832, the print server instructs the storage module 1200 to rewind (erase) the electronic film 1600, which preferably takes less than 1 minute for 30 pictures. In a further step 1834, a real-time clock within the storage module 1200 is preferably
10 updated. In a following step 1836, the storage module 1200 terminates the call.

As steps 1832, 1834, and 1836 are being performed, the EFSP, in a step 1838, catalogs the memory address location of the images at the printer server. Subsequently, in a step 1840, the EFSP sends a bill to the user.

One embodiment of the invention includes user software processes operating on
15 the user's computer connected to the EFSP. These may comprise Java applications operating on Internet browser software connected, via the Internet, to the EFSP. The network for delivering images to the EFSP is not necessarily the same as the network that the user uses to access images. With these Java applications, the user can specify the number of the prints in the order and preferences related to image manipulation, which can
20 be performed interactively or even in a teleconferencing format, etc.

In a step 1842, the electronic images are printed out at the printer server location on photo-quality paper (e.g., 5 x 7 glossy prints). In a next step 1844, the images are saved to accommodate any subsequent reprint requests. In a following step 1846, the printed pictures are mailed to the user.

The LEDs 1295 on the storage module 1200 are designed to keep the user apprised
25 of the status of the electronic film transfer from the storage module 1200 to the EFSP. Next to each one of the LEDs 1295 appears a status line, such as "connect" (i.e., the storage module 1200 is connecting to the EFSP), "sending" (the images are being downloaded, step 1802 in Figure 29), "finished" (the EFSP verifies that the images have
30 been downloaded, step 1830 in Figure 29), "unloading EFS" (the electronic film cartridge 800 is being unloaded), "rewinding" (the electronic film cartridge 800 is preparing itself

for a fresh set of pictures), "EFS ready" (the cartridge 800 has rewound and is ready for additional pictures), and "storage module full" (indicating that the storage module 1200 can not accept any additional images).

5 When the storage module 1200 is provided with the optional display 1280, the user can use the display 1280 to select the images that will be downloaded, to select the images that will be printed, and to manipulate a selected image (e.g., crop the image, lighten the image, darken the image, etc.). The user can also use the display 1280 to review, organize, and select images that were previously downloaded and stored by the EFSP. The user can also reload images from the EFSP into the storage module 1200.

10 When the storage module 1200 is provided with the optional video interface 1650, the user can display images from the storage module 1200 on a video device such as a television, computer monitor, and the like.

Although the foregoing has been a description and illustration of specific embodiments of the invention, various modifications and changes can be made thereto
15 by persons skilled in the art, without departing from the scope and spirit of the invention as defined by the following claims.

WHAT IS CLAIMED IS:

1. A portable, handheld, storage module that allows a user to easily store, carry, and view quality digital images, comprising:

an interface configured to receive one or more digital images from a removable storage device;

a memory for storing said one or more digital images, said memory configured to allow a user to arrange said one or more digital images as one or more volumes; and

a display for showing said one or more digital images.

2. The storage module of Claim 1, wherein said display is configured to show a plurality of thumbnail images of said one or more digital images.

3. The storage module of Claim 1, wherein said storage module further comprises an output interface for displaying one or more of said digital images on an external display device.

4. The storage module of Claim 3, wherein said external display device is a television.

5. The storage module of Claim 3, wherein said external display device is a projector.

6. The storage module of Claim 3, wherein said external display device is a computer monitor.

7. The storage module of Claim 3, further configured to send a selected digital image to a cellular telephone for display by said cellular telephone.

8. The storage module of Claim 3, wherein said external display device is a printer.

9. The storage module of Claim 3, wherein said external display device is a virtual reality headset.

10. The storage module of Claim 1, further comprising a modem.

11. The storage module of Claim 10, wherein said modem is configured to download at least one of said one or more digital images to an Internet site.

12. The storage module of Claim 10, wherein said modem is configured to download at least one of said one or more digital images through an Internet site to a remote display device.

5 13. The storage module of Claim 10, wherein said modem is configured to download at least one of said one or more digital images to a remote display device.

14. The storage module of Claim 13 wherein said external display device is a printer.

15. The storage module of Claim 13 wherein said external display device is a photo-printer.

10 16. The storage module of Claim 1, further comprising a computer interface.

17. The storage module of Claim 1, where said external storage device is an electronic film cartridge.

18. The storage module of Claim 1, where said external storage device is a disc.

15 19. The storage module of Claim 18, where said disc is an optical disc.

20. The storage module of Claim 18, where said disc is a magnetic disc.

21. The storage module of Claim 1, where said external storage device is a flash memory.

20 22. The storage module of Claim 1, where said external storage device is a nonvolatile memory.

23. The storage module of Claim 1, further comprising a digital audio system configured to play digital audio files associated with said one or more digital images.

25 24. A method for easily storing, carrying, and viewing digital images, comprising the steps of:

receiving one or more digital images from an external storage device;

storing said digital images as in one or more volumes in a first compressed data format;

selecting one of said digital images as a selected image;

30 decompressing said selected image to produce a decompressed image;

displaying said decompressed image on a display.

25. The method of Claim 24, further comprising the step of processing said decompressed image to enhance viewability of said decompressed image.

26. The method of Claim 24, further comprising the step of compressing said decompressed image using a second compression algorithm to produce a recompressed image and storing said recompressed image in one or more of said volumes.

27. A portable, handheld, storage module that allows users to easily store, carry, and view digital images, comprising:

an interface configured to receive one or more digital images from a removable storage device;

10 a memory for storing the digital images, said memory configured to allow a user to arrange said one or more digital images as one or more volumes; and;

display means for displaying said image.

28. A storage module, comprising:

15 an interface configured to receive one or more digital images from a removable storage device;

storage means for storing said one or more digital images, said storage means configured to allow a user to arrange said one or more digital images as one or more volumes; and

20 display means for displaying said image.

29. A storage module, comprising:

an interface configured to receive one or more digital images from a removable storage device;

25 a memory for storing digital images, said memory configured to allow a user to group a first plurality of said digital images in a first logical volume and to group a second plurality of digital images in a second logical volume; and

a display for showing said digital images.

30. An electronic film cartridge, comprising:

a microcontroller;

30 a computer interface coupled to said microcontroller;

a first memory coupled to said microcontroller;

a DSP coupled to said microcontroller;
a second memory coupled to said DSP;
an analog-to-digital converter coupled to said DSP; and
an imager coupled to said analog-to-digital converter.

5 31. The electronic film cartridge of Claim 30, further comprising a
microphone coupled to said microcontroller.

32. The electronic film cartridge of Claim 30, further comprising a display
coupled to said microcontroller.

10 33. The electronic film cartridge of Claim 30, further comprising a pressure
switch coupled to said microcontroller.

34. The electronic film cartridge of Claim 30, further comprising a clock
coupled to said DSP and said analog-to-digital converter.

35. The electronic film cartridge of Claim 30, wherein said computer
interface comprises a PCMCIA II interface or a USB interface.

15 36. The electronic film cartridge of Claim 30, wherein said first memory
comprises a nonvolatile memory.

37. The electronic film cartridge of Claim 30, wherein said second memory
comprises a volatile memory.

20 38. A carrier for an electronic film cartridge having a computer interface,
said carrier comprising:

a cavity configured to accept said electronic film cartridge;
a door configured to cover said cavity; and
a connector configured to provide communication between said
computer interface of said electronic film cartridge and a computer.

25 39. A carrier for an electronic film cartridge, said carrier comprising:
a cavity configured to accept said electronic film cartridge;
a door configured to cover said cavity; and
a computer interface configured to communicate with said electronic
film cartridge.

30 40. The carrier of Claim 39, wherein said computer interface comprises a
PCMCIA II interface or a USB interface.

41. A storage module for use with an electronic film cartridge, said storage module comprising:

a processor;

a memory coupled to said processor; and

5 a communication interface configured to be coupled to said electronic film cartridge.

42. The storage module of Claim 41, further comprising a display for viewing images stored on said electronic film cartridge.

10 43. The storage module of Claim 41, further comprising a computer interface port.

44. The storage module of Claim 43, wherein said computer interface port comprises a PCMCIA II interface port or a USB interface port.

45. The storage module of Claim 41, wherein said communication interface comprises a PCMCIA II interface or a USB interface.

15 46. The storage module of Claim 41, wherein said communication interface comprises a phone jack.

47. The storage module of Claim 46, wherein said phone jack comprises an RJ-11 jack.

20 48. A method for capturing an image on an electronic film cartridge, comprising the acts of:

polling for a first activation trigger;

activating an imager to capture a first image after receiving said first activation trigger;

storing said first image in a first memory;

25 activating said imager to capture a second image;

storing said second image in said first memory; and

dark current correcting said first image using data from said second image.

30 49. The method of Claim 48, further comprising the act of polling a pressure switch.

50. The method of Claim 48, further comprising the act of providing power to a DSP after receiving said first activation trigger.

51. The method of Claim 48, further comprising the act of polling for a second activation trigger before storing said first image in said first memory.

5 52. The method of Claim 48, further comprising the act of compressing said first image.

53. The method of Claim 48, wherein the act of polling for an activation trigger comprises the act of polling a microphone.

10 54. The method of Claim 48, wherein the act of storing said first image in said first memory comprises the act of storing said first image in said first memory after a predetermined time period.

55. The method of Claim 48, wherein the act of storing said first image in a first memory comprises the act of storing said first image in a cache memory.

15 56. The method of Claim 48, further comprising the act of storing said first image in a second memory.

57. The method of Claim 56, wherein the act of storing said first image in a second memory comprises the act of storing said first image in a nonvolatile memory.

20 58. A method of processing electronic image data, comprising the acts of:
capturing said electronic image data on an electronic film cartridge;
transferring said electronic image data to a storage module having a
communication port;
establishing communication with a communication network using said
communication port; and
transferring said electronic image data to a computer over said
25 communication network.

59. The method of Claim 58, further comprising the act of printing a picture corresponding to said electronic image data.

60. The method of Claim 59, further comprising the act of delivering said picture to a recipient.

30 61. The method of Claim 58, further comprising the act of compressing said image data.

62. The method of Claim 61, wherein the act of compressing said image data further comprises the act of selecting from a group of compression algorithms an algorithm that will result in more compression of said image data than other algorithms in said group of compression algorithms.

5 63. The method of Claim 58, wherein the act of establishing communication with a communication network comprises the act of establishing communication with at least one of the Internet, an intranet, a public switched telephone network, an integrated services digital network, a cellular telephone network, or a satellite communication network.

10 64. The method of Claim 58, wherein the act of transferring said electronic image data to a computer comprises the act of transferring said electronic image data to a personal computer.

15 65. The method of Claim 58, wherein the act of transferring said electronic image data to a computer comprises the act of transferring said electronic image data to an electronic film service provider.

66. A method of connecting a transportable image storage device with a communication network, the method comprising:

establishing a first communication link between the transportable image storage device and a remotely located device;

20 obtaining, via the first communication link, the telephone number of a local access device;

establishing a second communication link between the transportable storage device and the local access device; and

25 transmitting, via the second communication link, at least one image from the transportable storage device to the local access device.

67. A method comprising:

establishing a first communication link with a remotely located device;

obtaining, via the first communication link, a telephone number of a local access device; and

30 establishing a second communication link with the local access device.

68. A transportable device for transmitting digital images over a network, the device comprising:

at least one digital image;

5 a first memory configured to store a first telephone number that dials a remotely located computer; and

10 a first processor that is configured to establish a first communication link with the remotely located computer, wherein the processor is configured to receive, via the first communication link, a second telephone number that identifies a local access provider, and wherein the first processor is further configured to establish a second communication link that transmits the digital image to the local access provider.

69. A device comprising:

a memory configured to store a first telephone number; and

15 a processor that is configured to establish a first communication link using the first telephone number, wherein the processor is configured to receive, via the first communication link, a second telephone number that identifies a local access device, and wherein the processor is further configured to establish a second communication link with the local access provider.

70. A device comprising:

20 a memory configured to store an electronic address; and

25 a processor that is configured to establish a first communication link with the electronic address, wherein the processor is configured to receive, via the first communication link, a second electronic address that identifies a local access device, and wherein the processor is further configured to establish a second communication link with the local access provider.

71. A computer comprising:

a first port that is configured to establish a communication link with a remotely located device; and

30 a processor in communication with the first port, wherein the processor is configured to identify the location of the remotely located device, and wherein

the processor is further configured to send a telephone number that identifies a local access provider to the remotely located device.

72. A computer comprising:

5 a first port that responds to a telephone call from a remotely located device, the telephone call having an originating telephone number associated therewith; and

10 a processor in communication with the first port, wherein the processor is configured to identify a local access telephone number based in part on the originating telephone number, and wherein the processor is further configured to send the local access telephone number to the remotely located device .

73. A method comprising:

receiving the origination telephone number of a remotely located device;
determining a local access telephone number based on at least the origination telephone number; and

15 sending the local access telephone number to the remotely located device.

74. A method comprising:

determining the location of a remotely located device;
20 sending a local access telephone and password to the remotely located device.

75. A computer comprising:

a first port that responds to a communication link with from a remotely located device wherein the remotely located device has an electronic address associated therewith; and

25 a processor in communication with the first port, wherein the processor is configured to identify a second electronic address based in part on the first electronic address, and wherein the processor is further configured to send the second electronic address to the remotely located device .

76. A computer comprising:

30 a plurality of access telephone numbers;

a first port that responds to a telephone call from a remotely located device, wherein the telephone call transmits an originating telephone number; and

5 a processor in communication with the first port, wherein the processor is configured to select one of the access telephone numbers based in part on the originating telephone number, and wherein the processor is further configured to send the selected access telephone number to the remotely located device.

10 77. The computer of Claim 76, wherein the processor is further configured to receive indication that the selected access telephone number is no longer in use by the remotely located device.

78. The computer of Claim 77, where in the processor is further configured to indicate that the selected access telephone number is again available.

15 79. A method comprising:
maintaining a plurality of local access accounts that provide access to a network;
assigning a local access account to a remotely located computer; and
reassigning the local access account after the remotely located computer has transmitted digital images via the network.

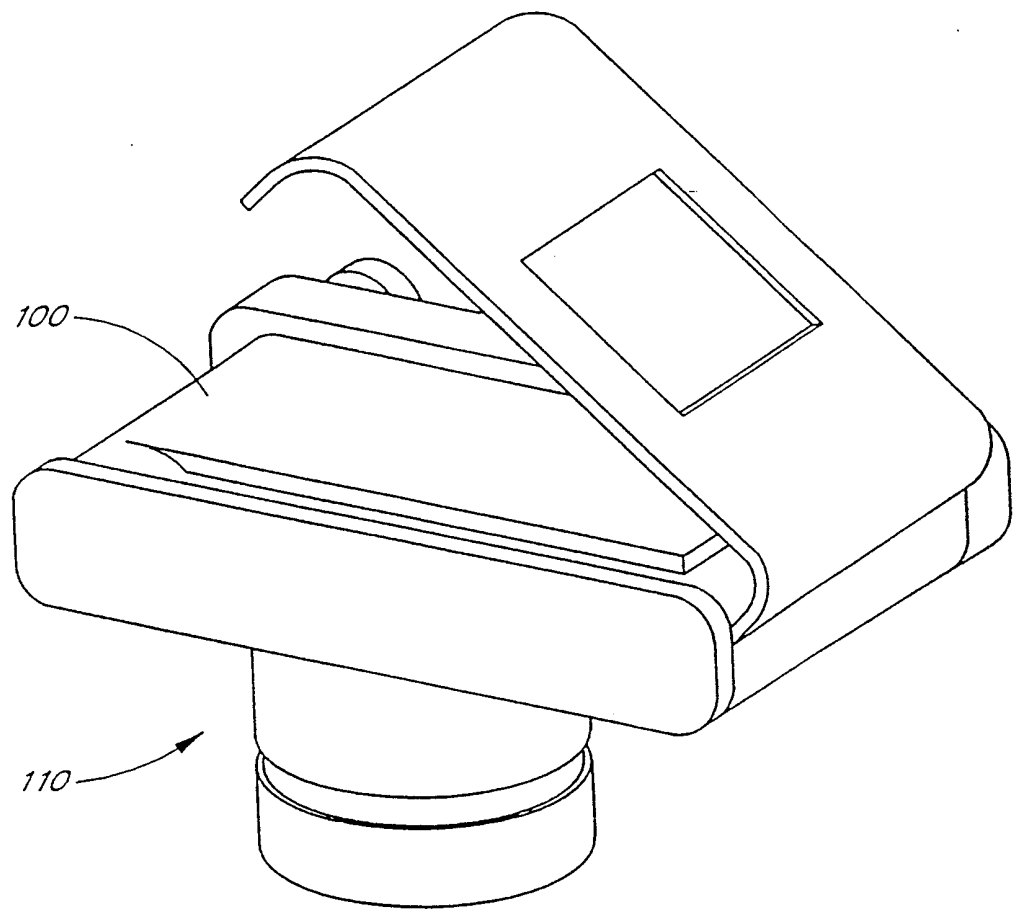

FIG. 1

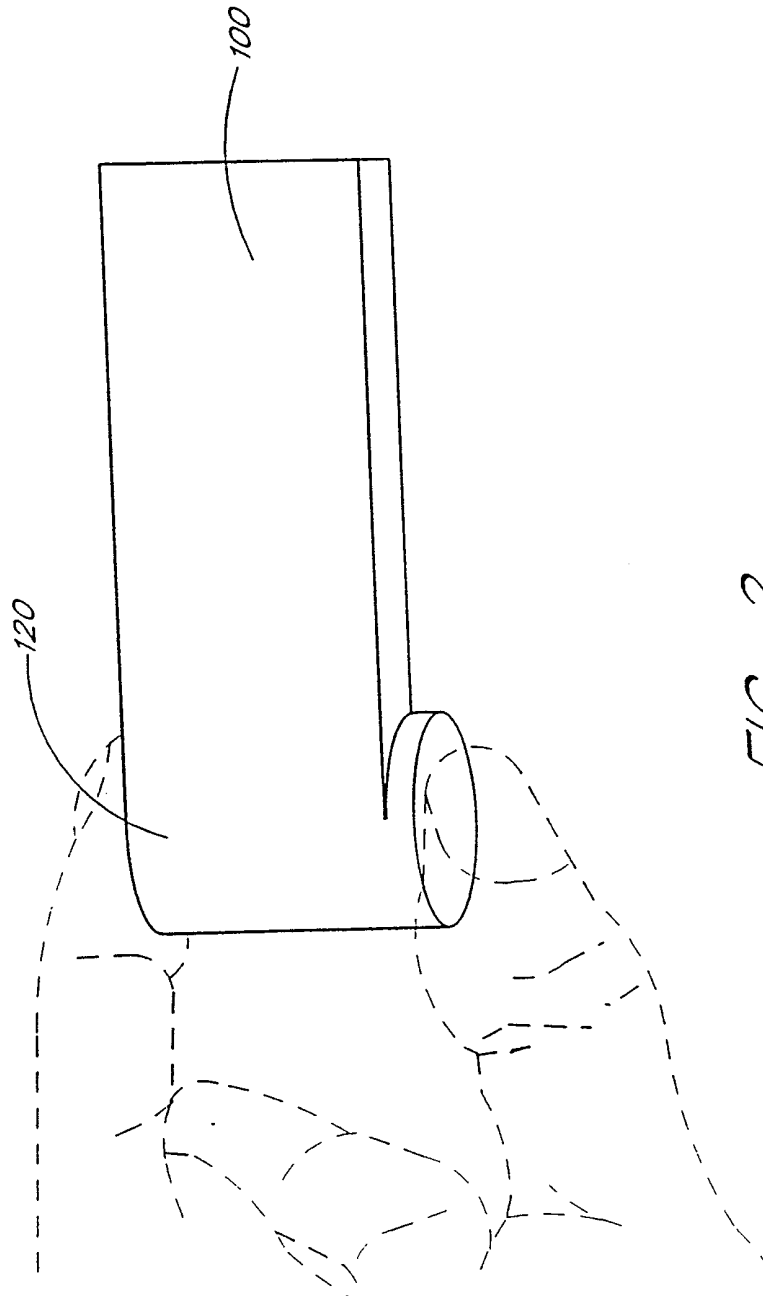

FIG. 2

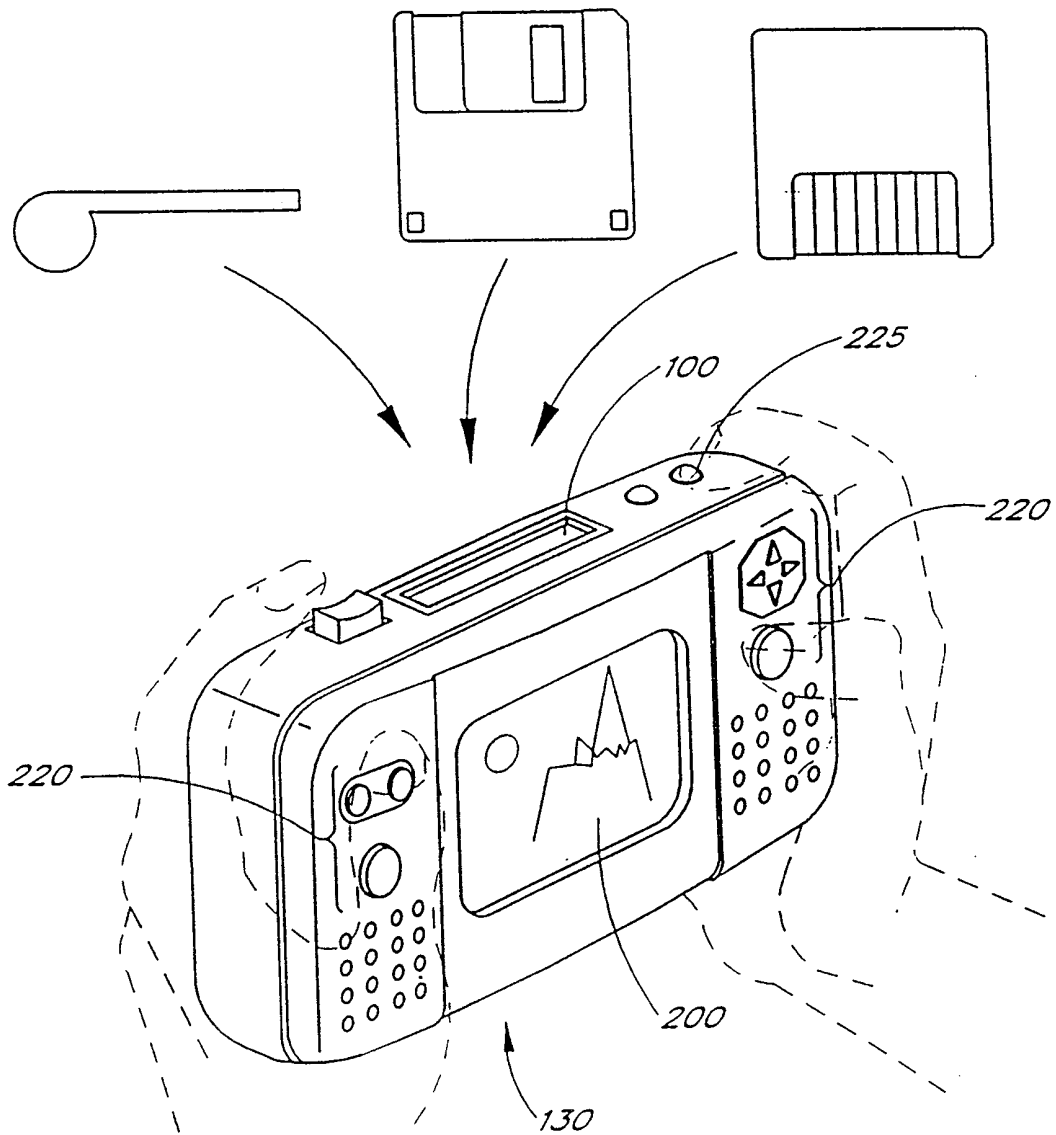

FIG. 3A

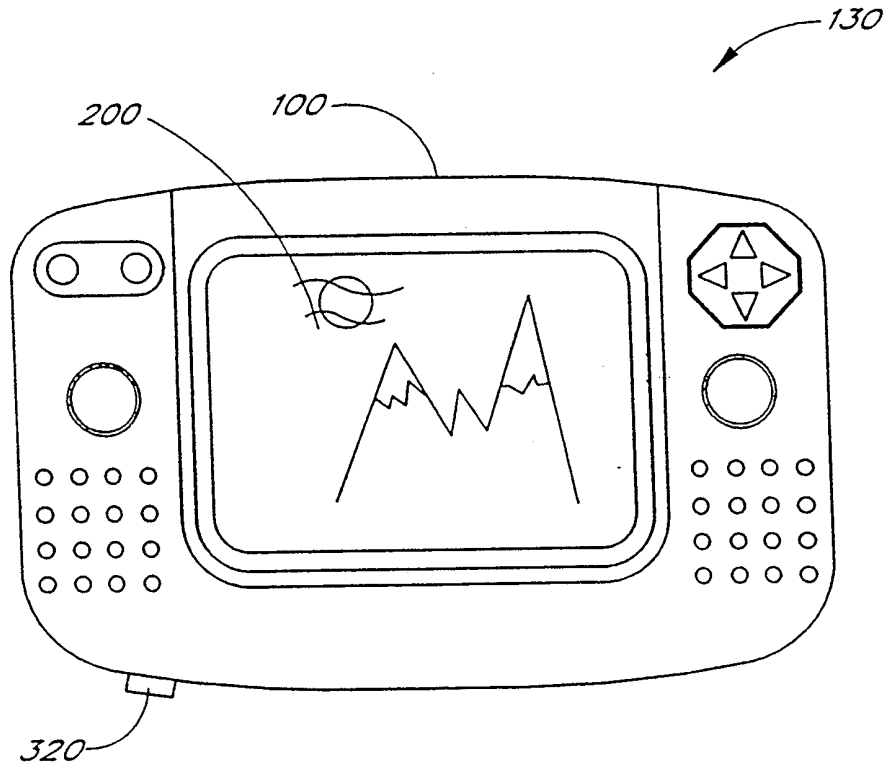

FIG. 3B

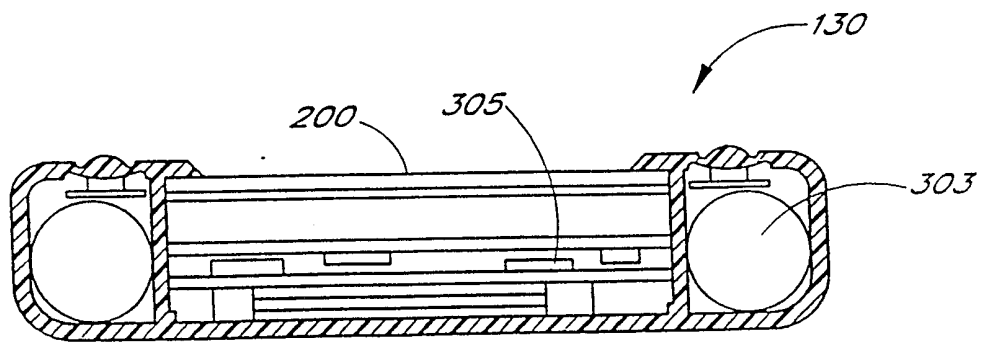

FIG. 3C

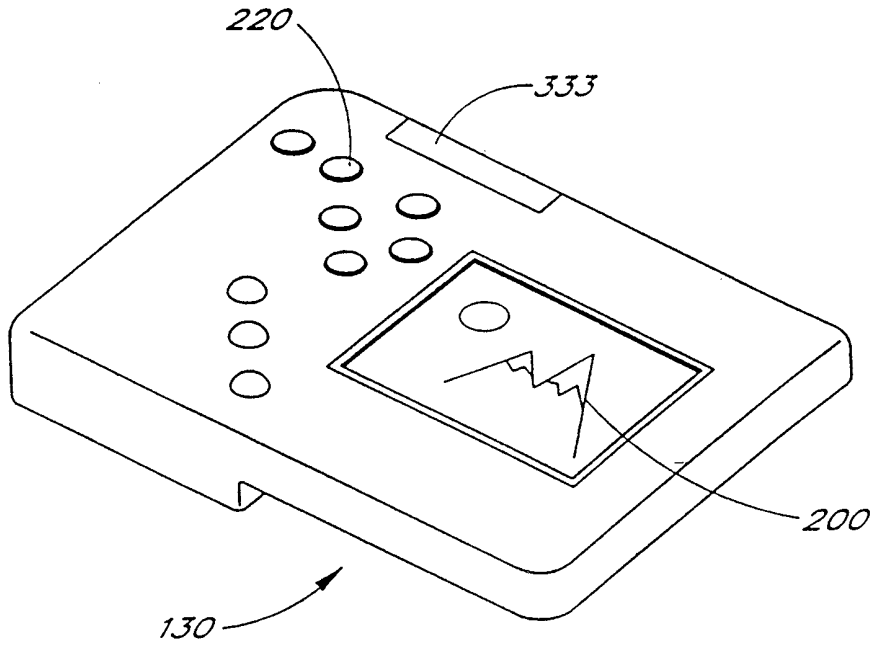

FIG. 3D

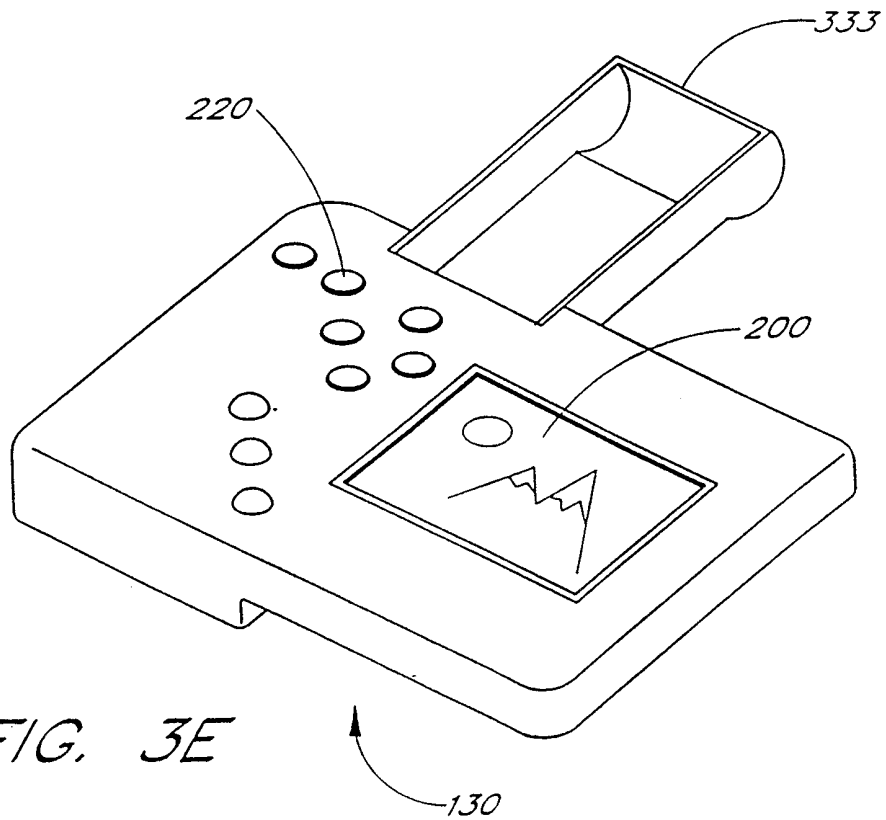

FIG. 3E

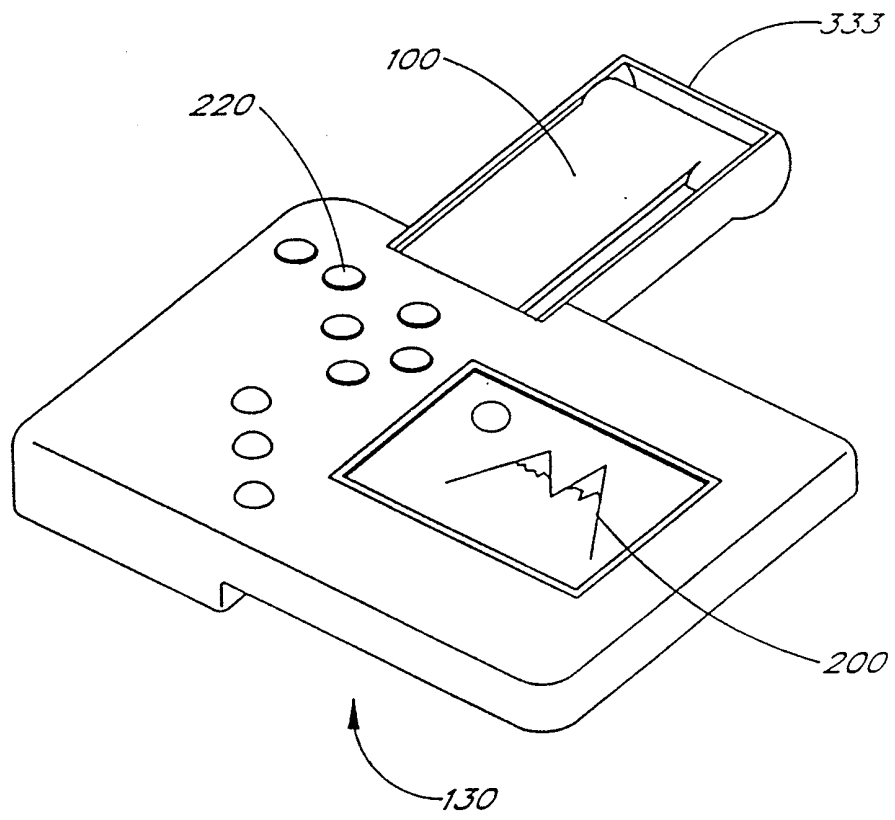

FIG. 3F

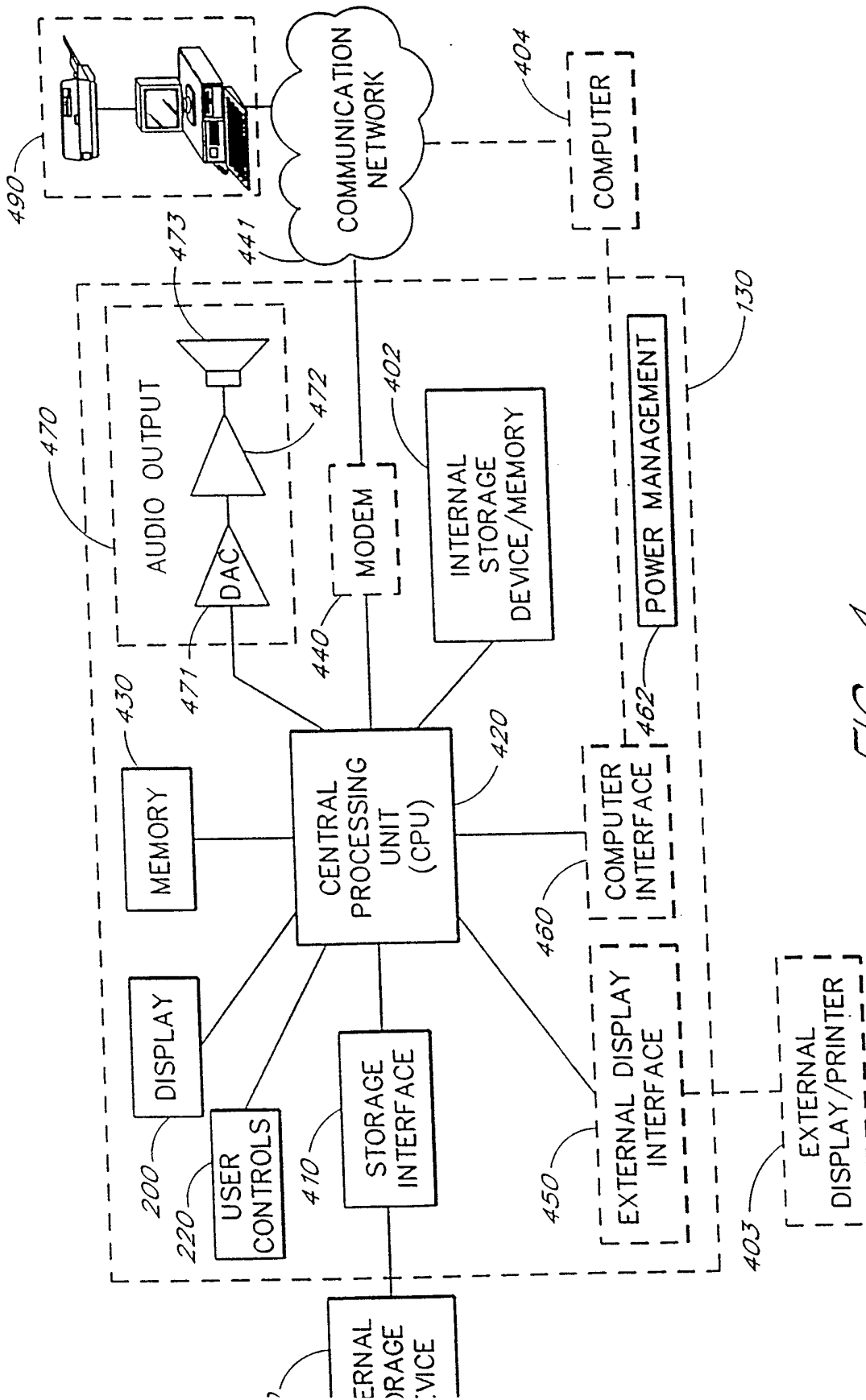

FIG. 4

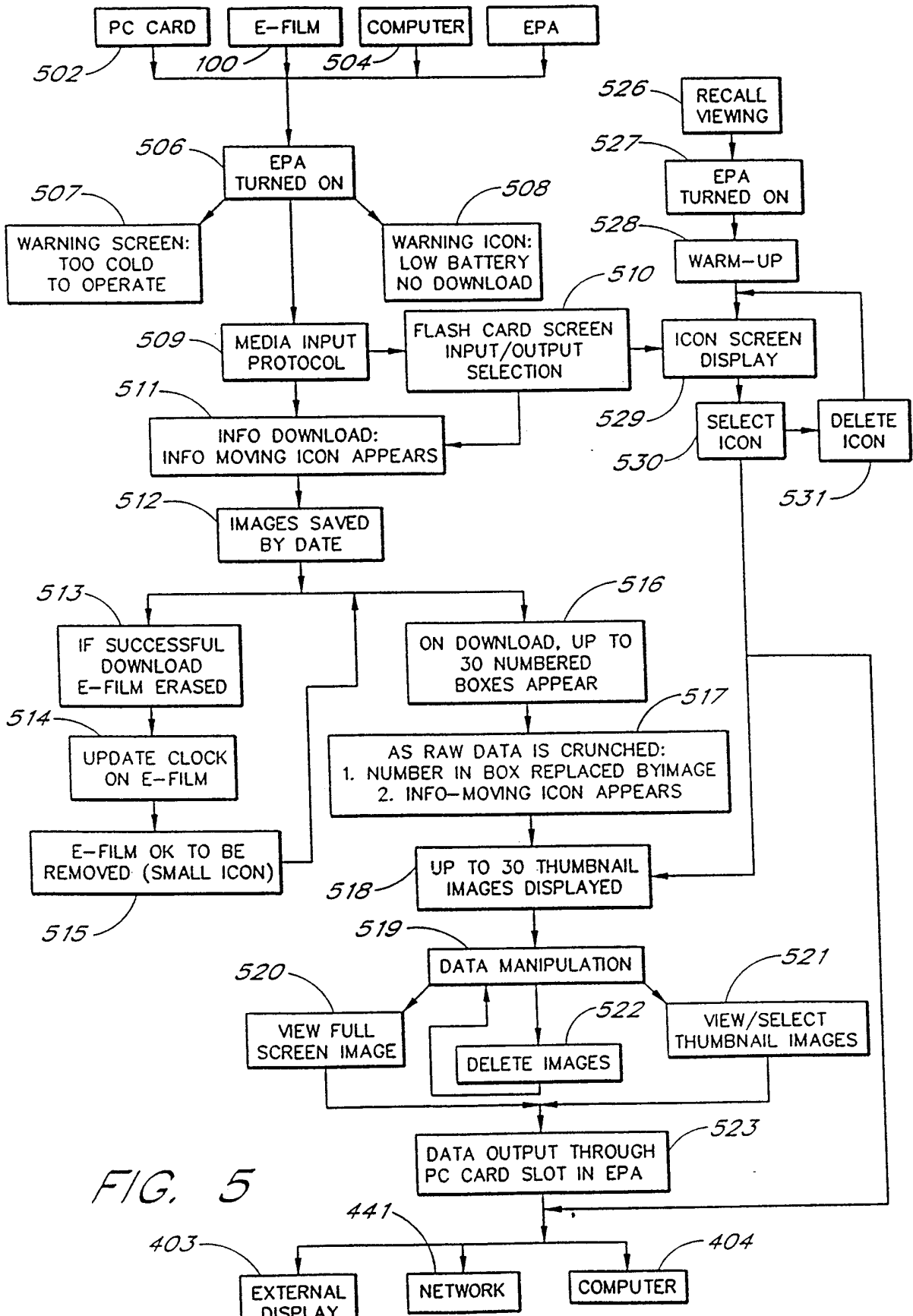

FIG. 5

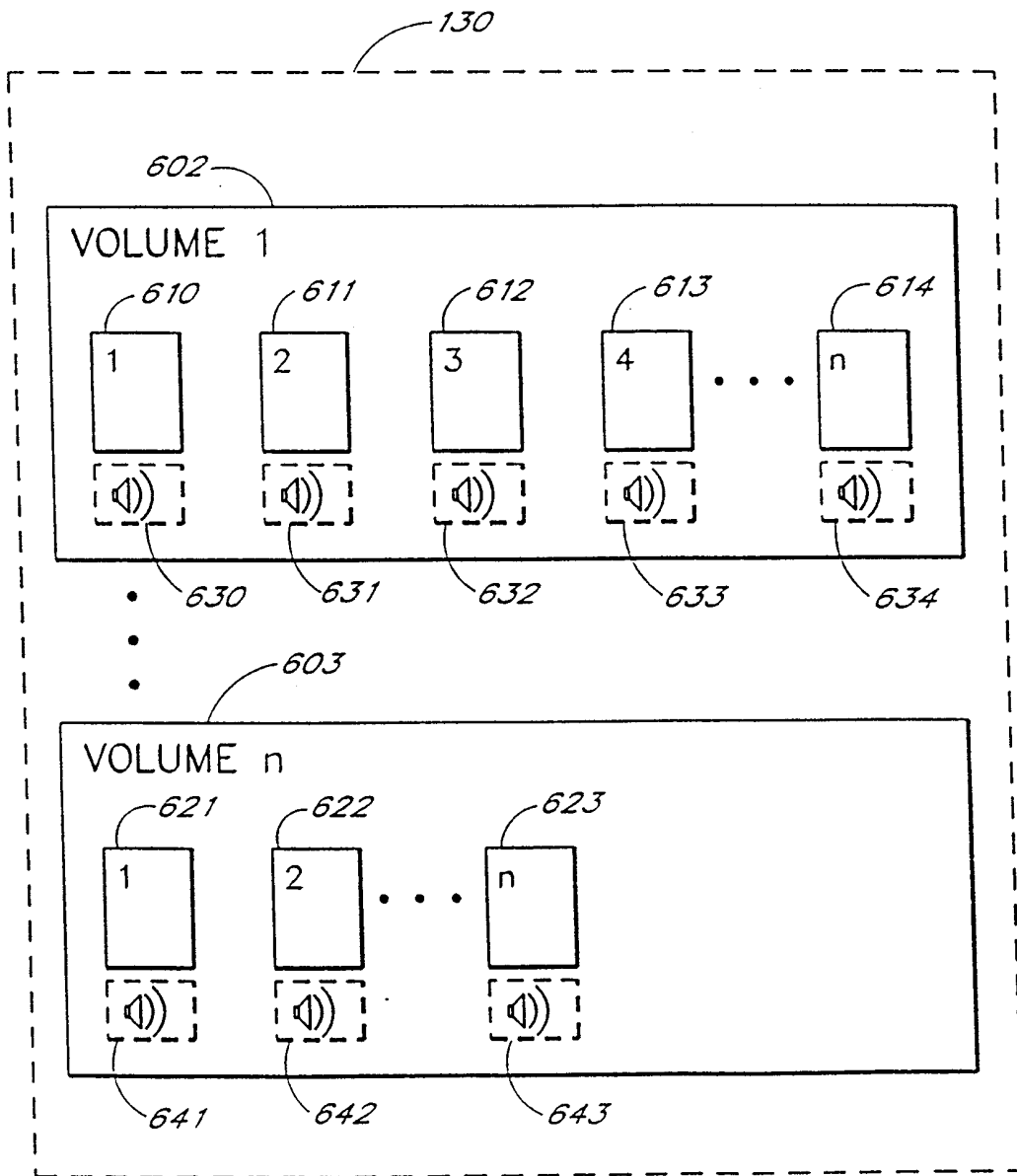

FIG. 6

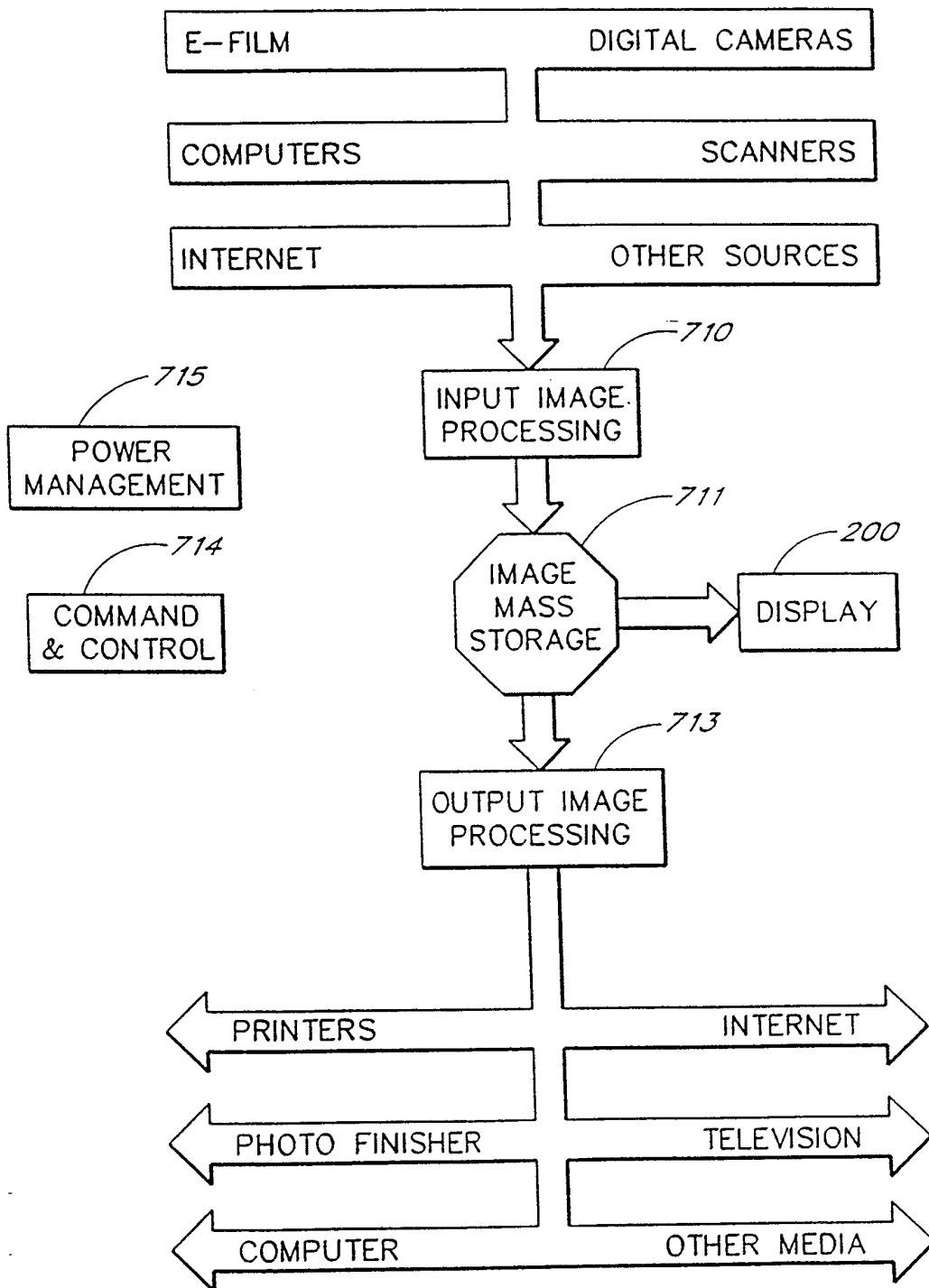

FIG. 7A

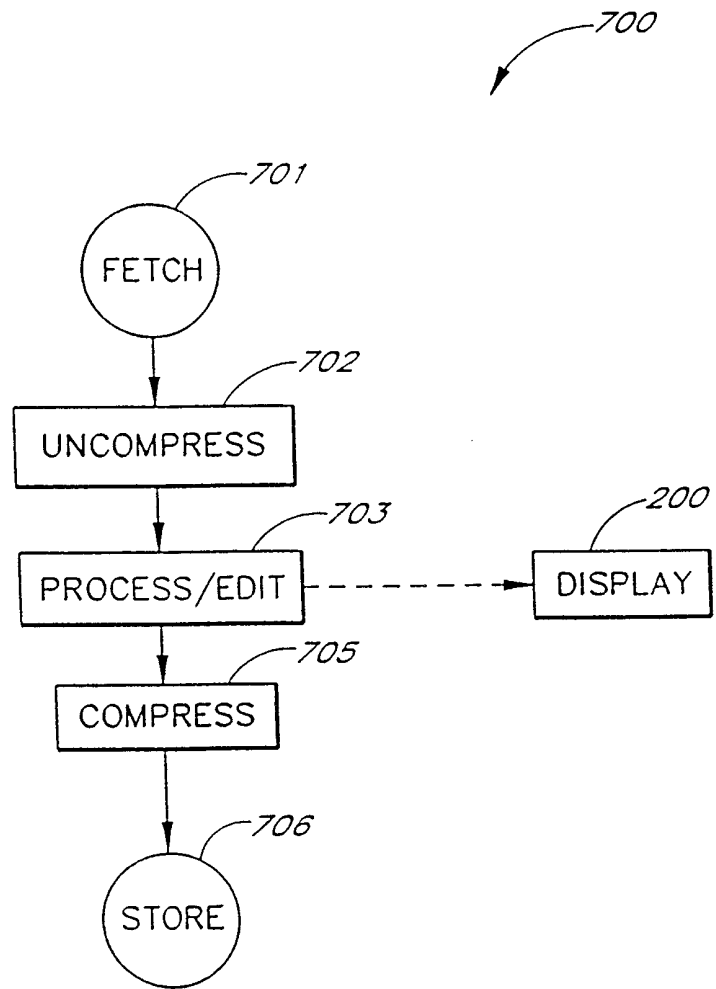

FIG. 7B

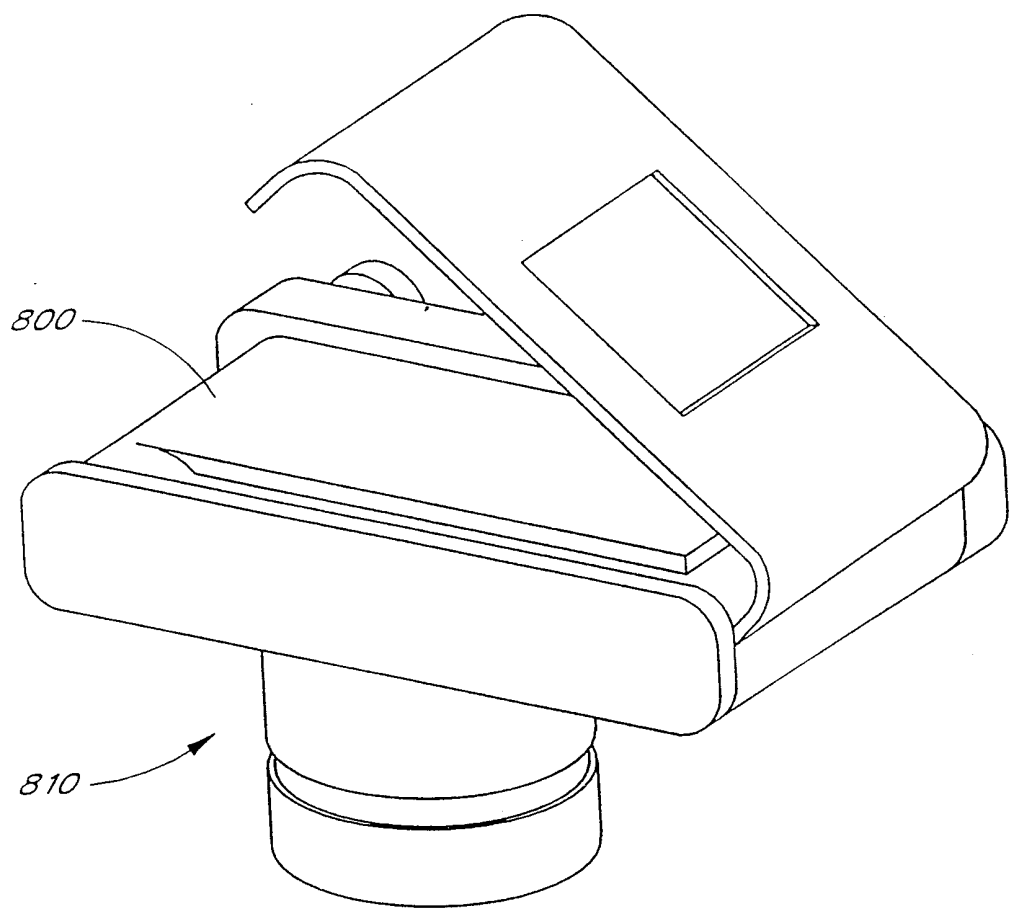

FIG. 8

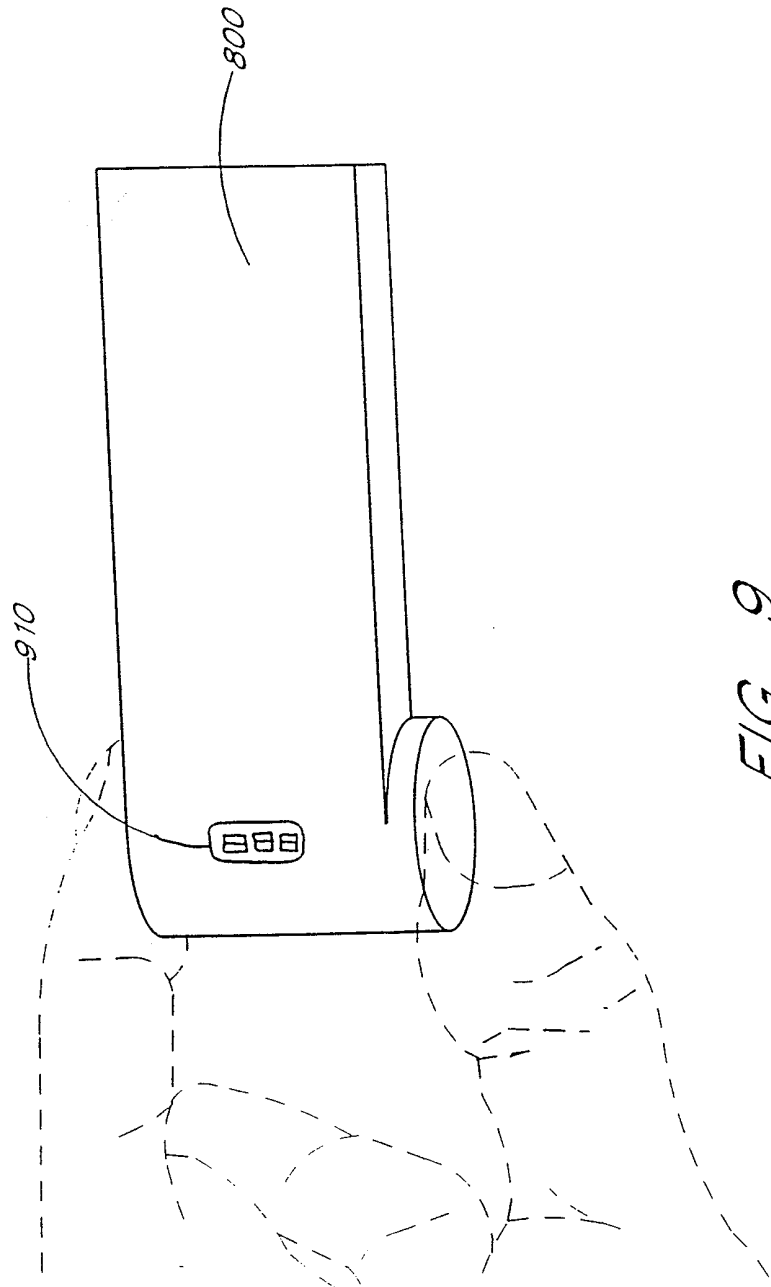

FIG. 9

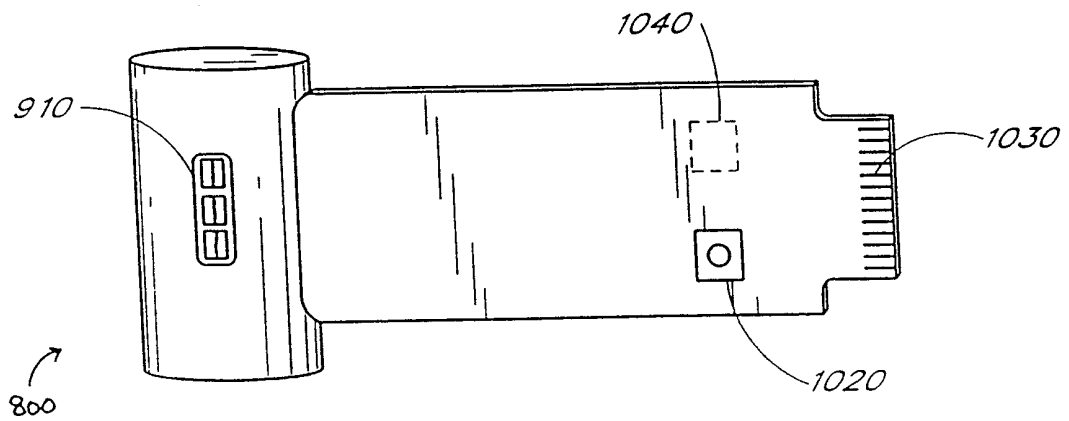

FIG. 10A

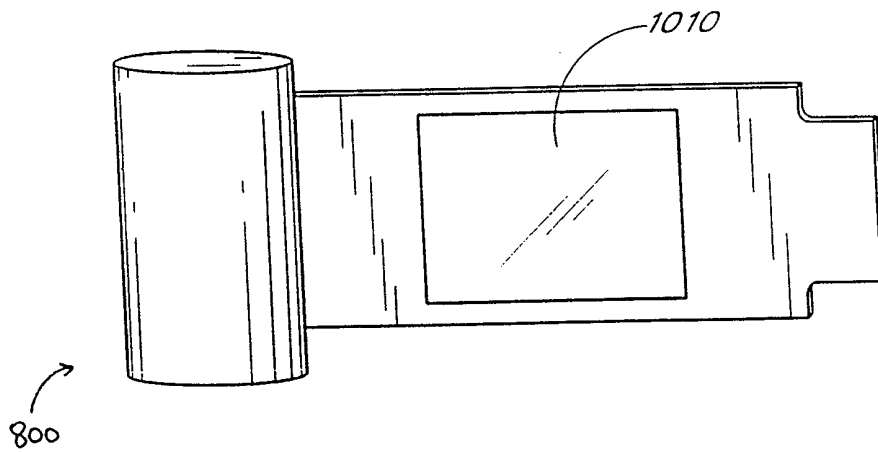

FIG. 10B

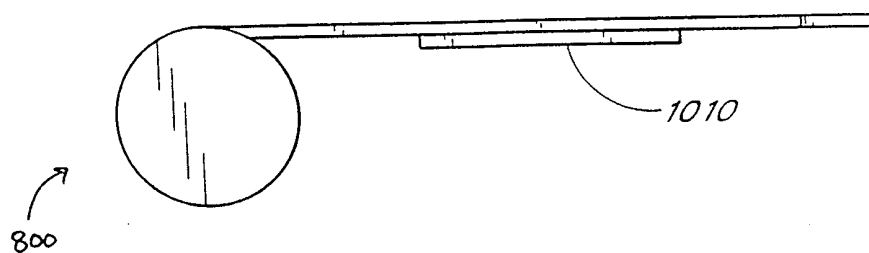

FIG. 10C

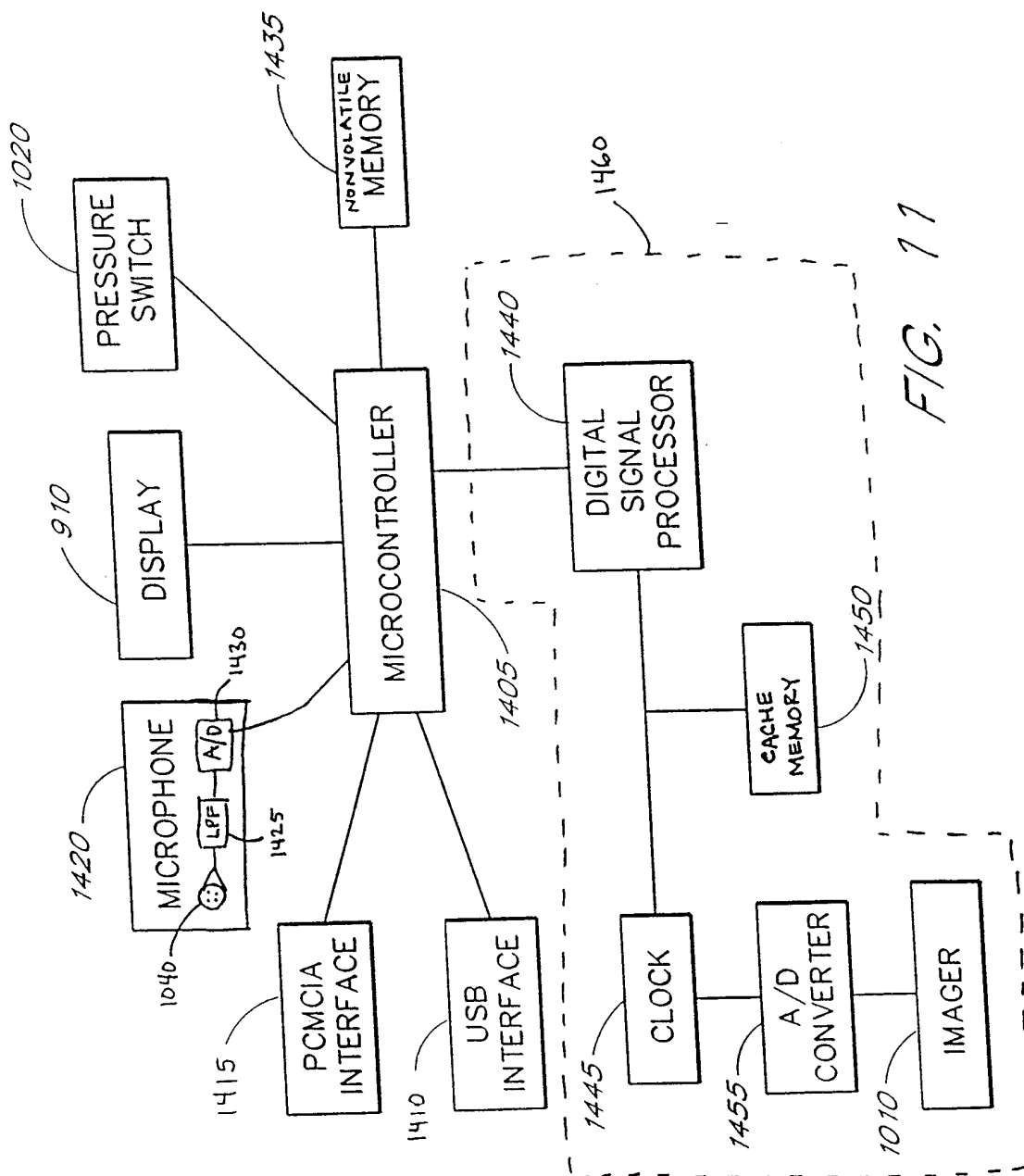

FIG. 11

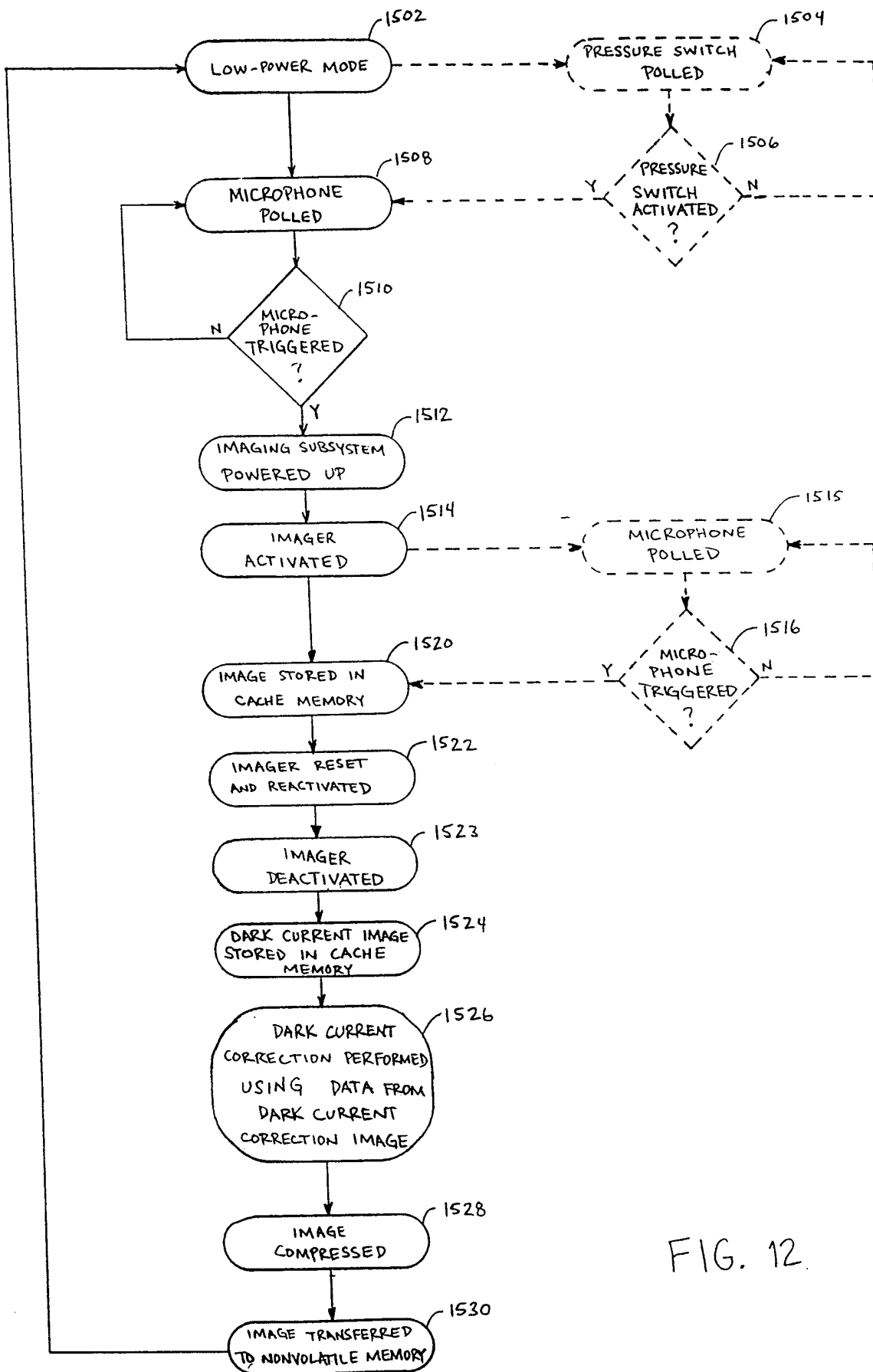

FIG. 12.

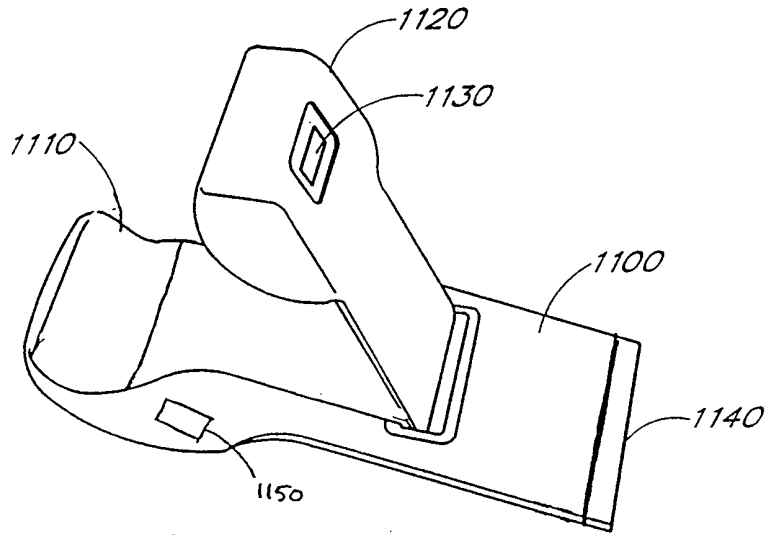

FIG. 13A

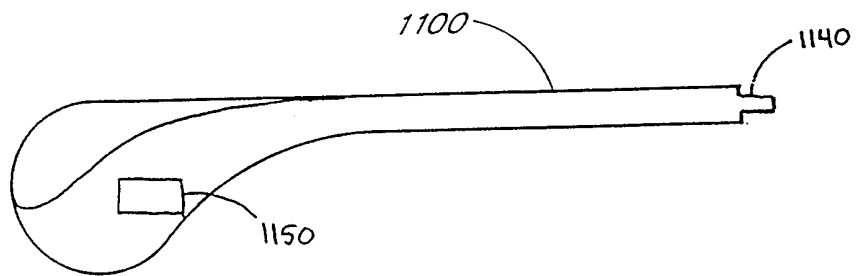
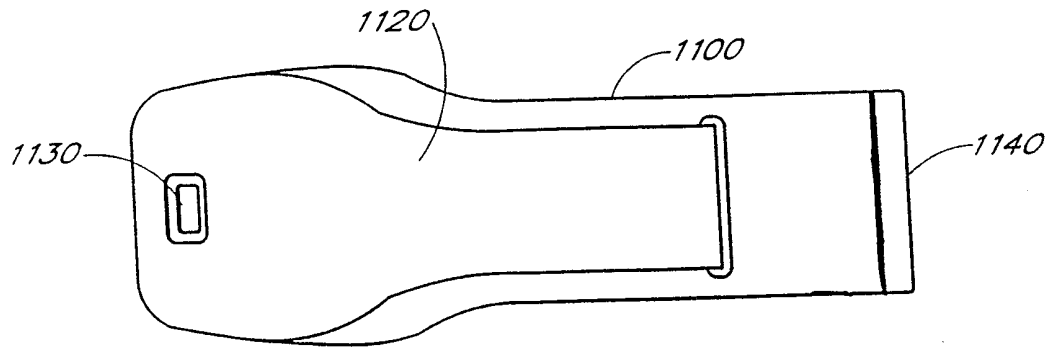

FIG. 13B



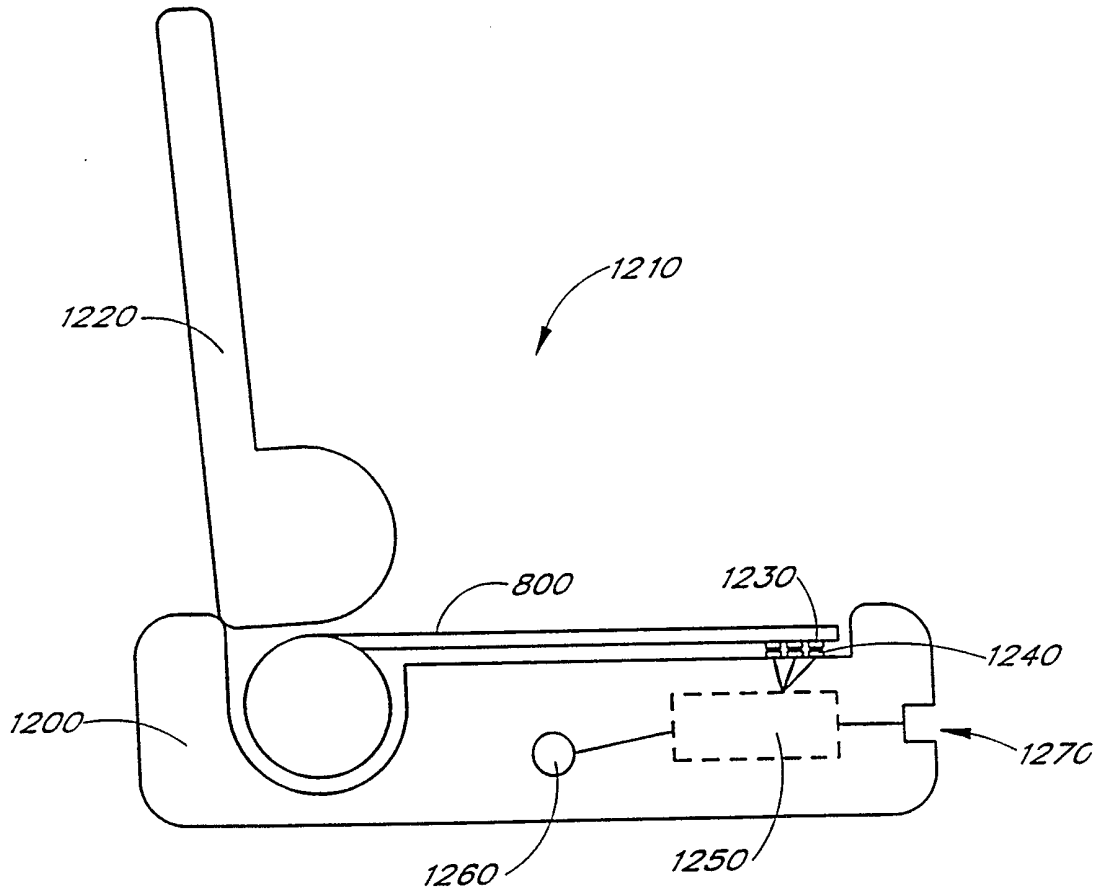
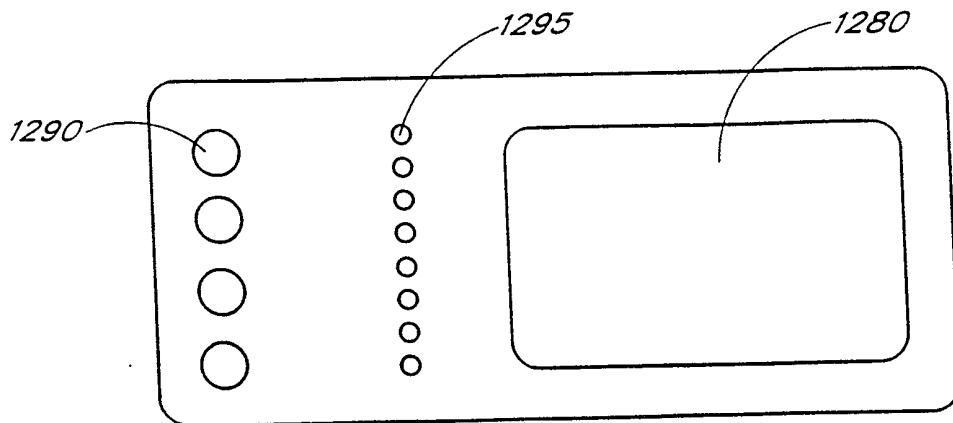

FIG. 14A



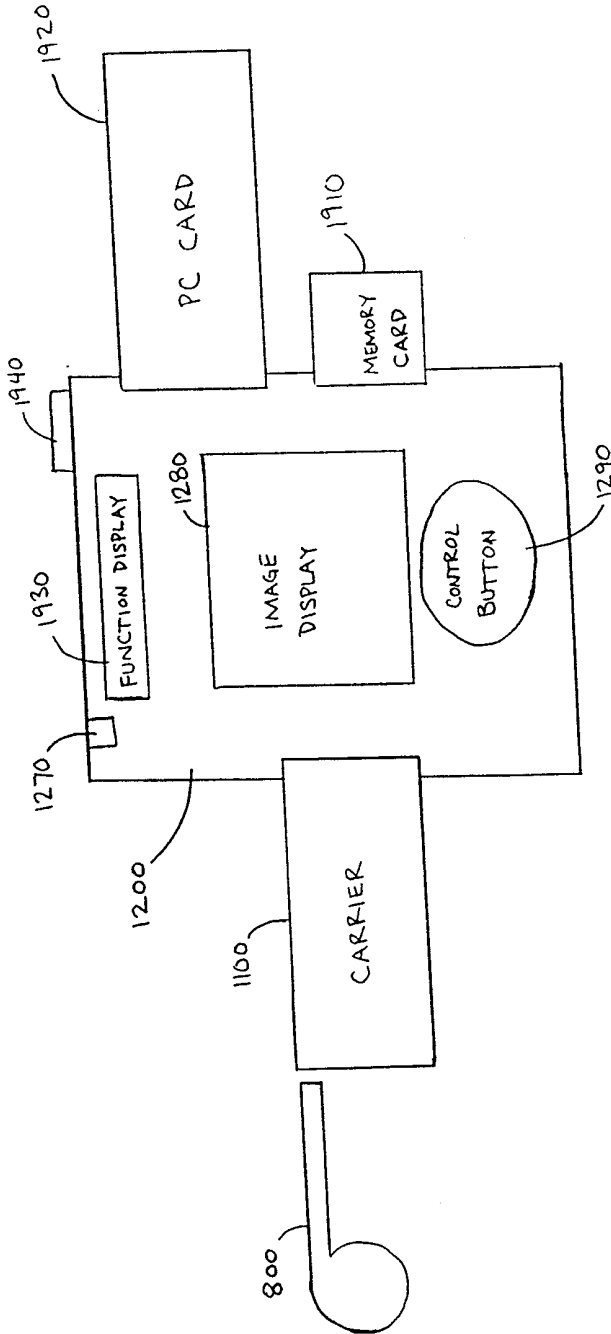

FIG. 15

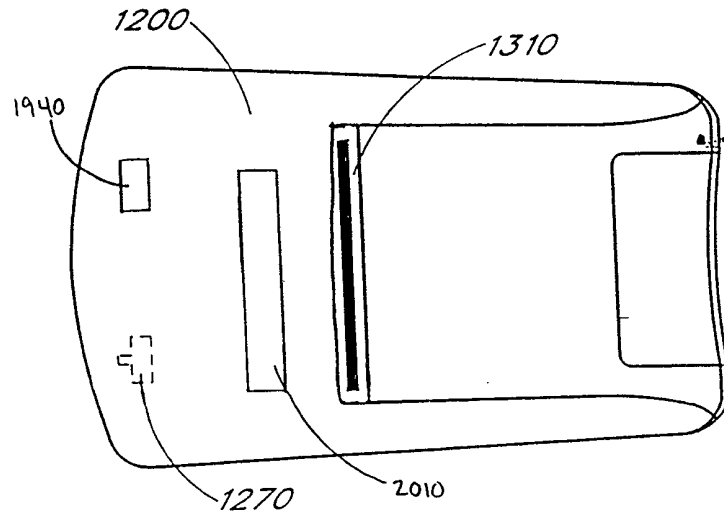

FIG. 16A

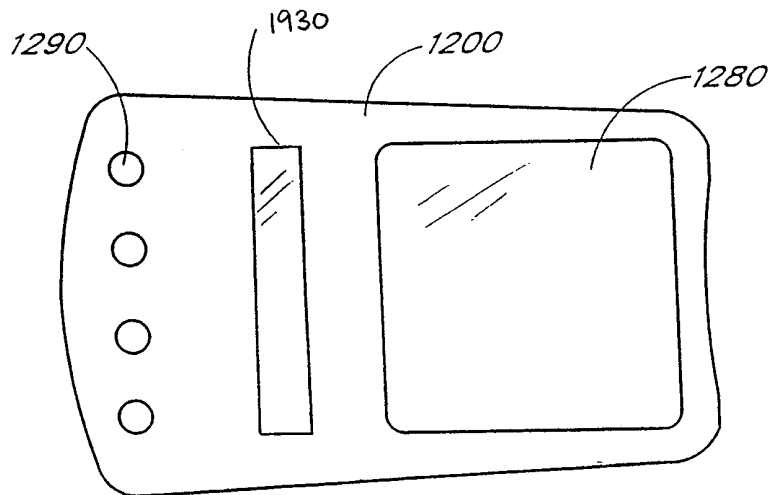

FIG. 16B

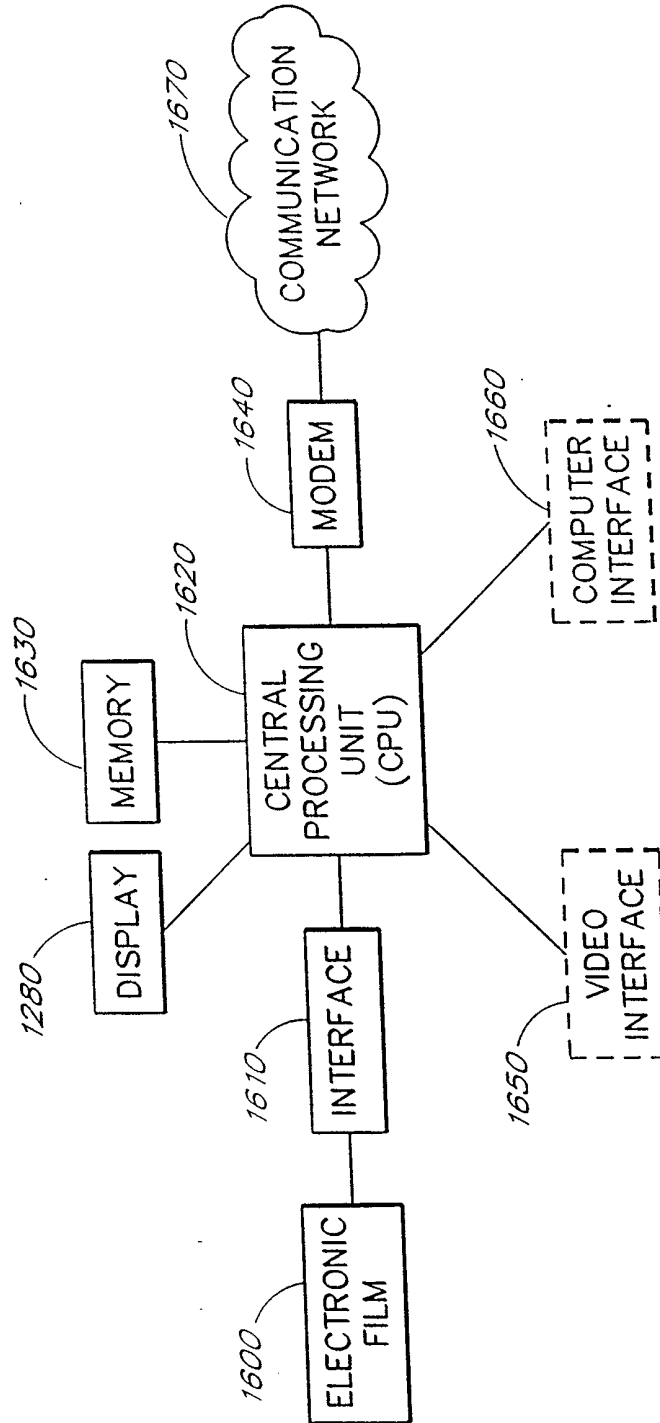

FIG. 17

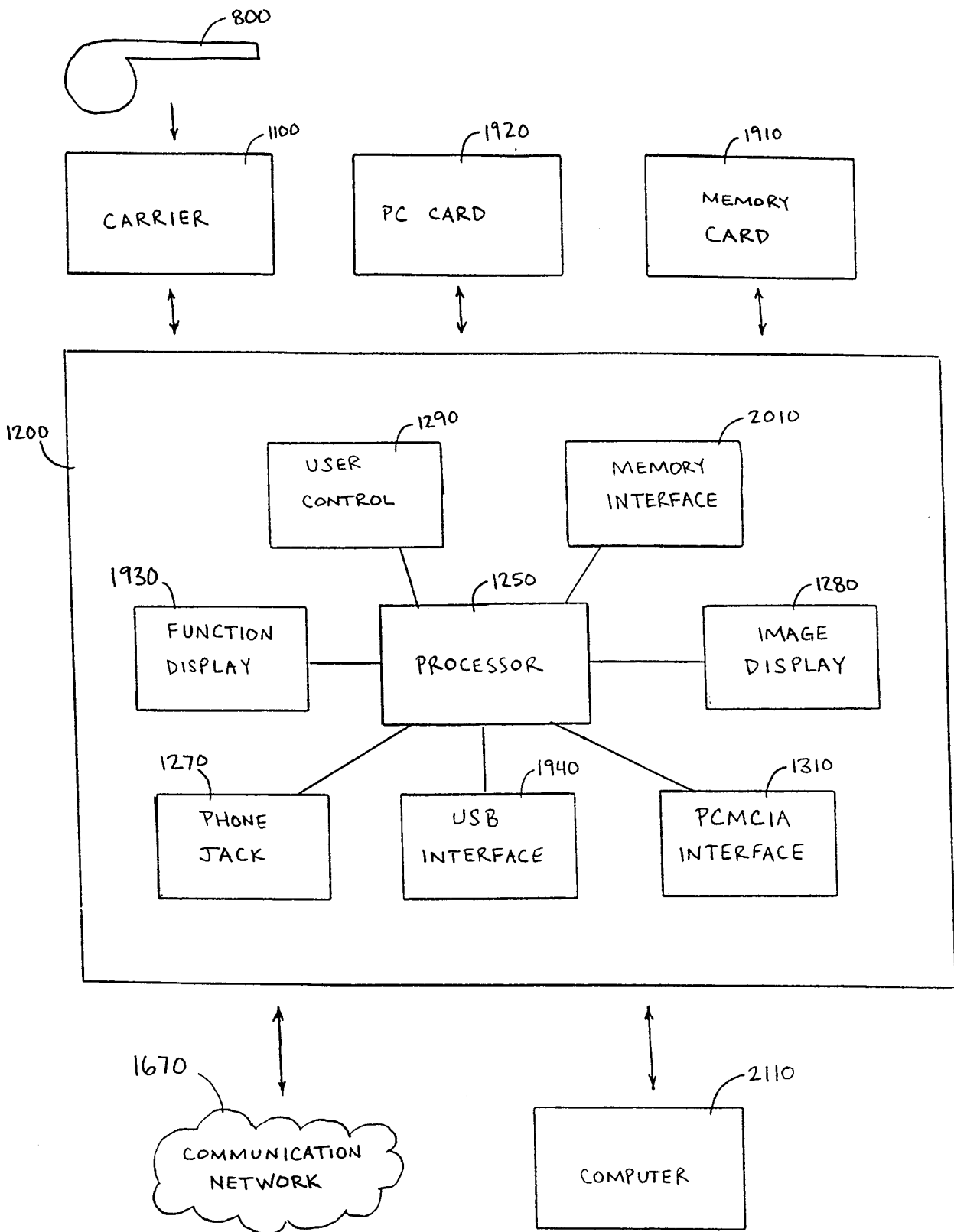

FIG 18

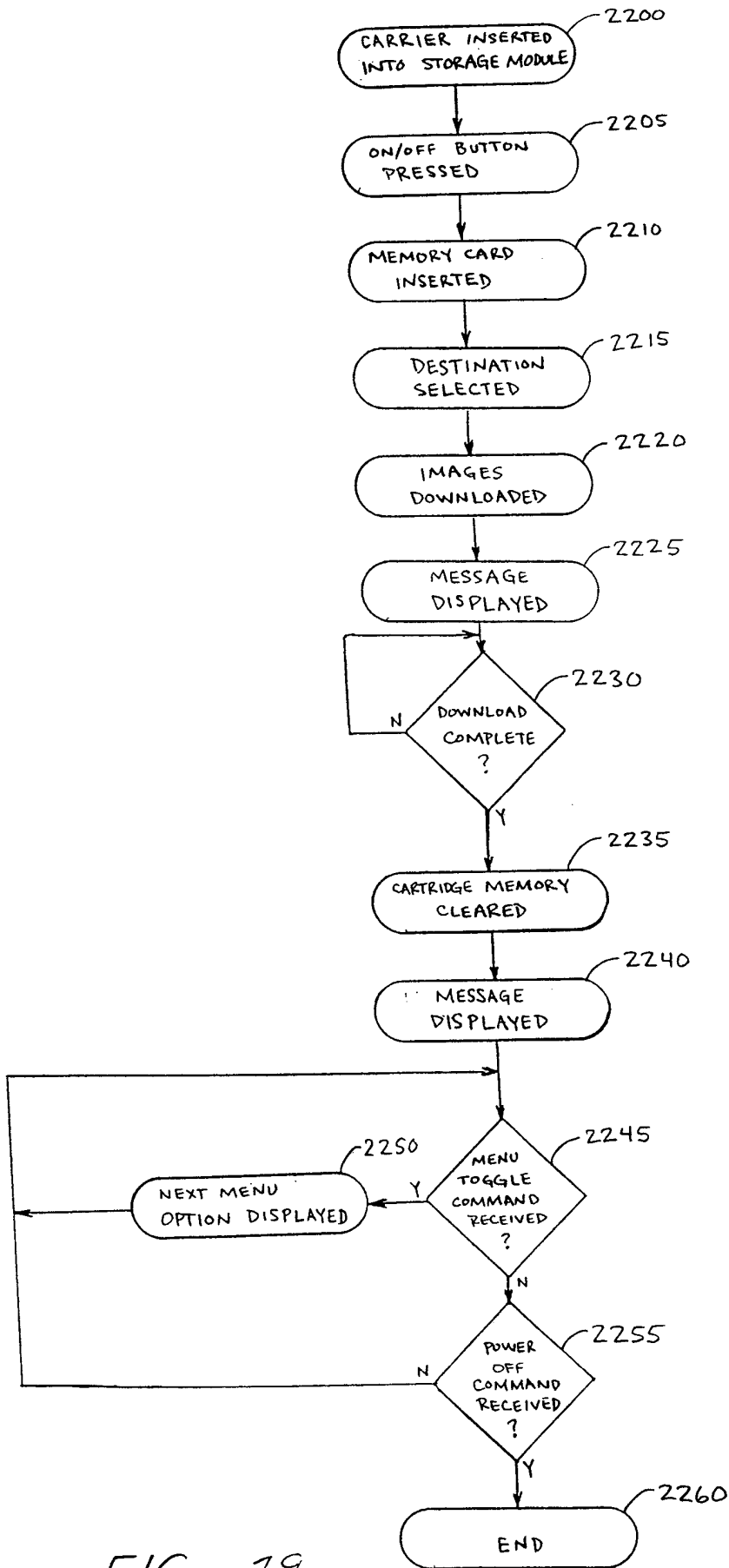

FIG. 19

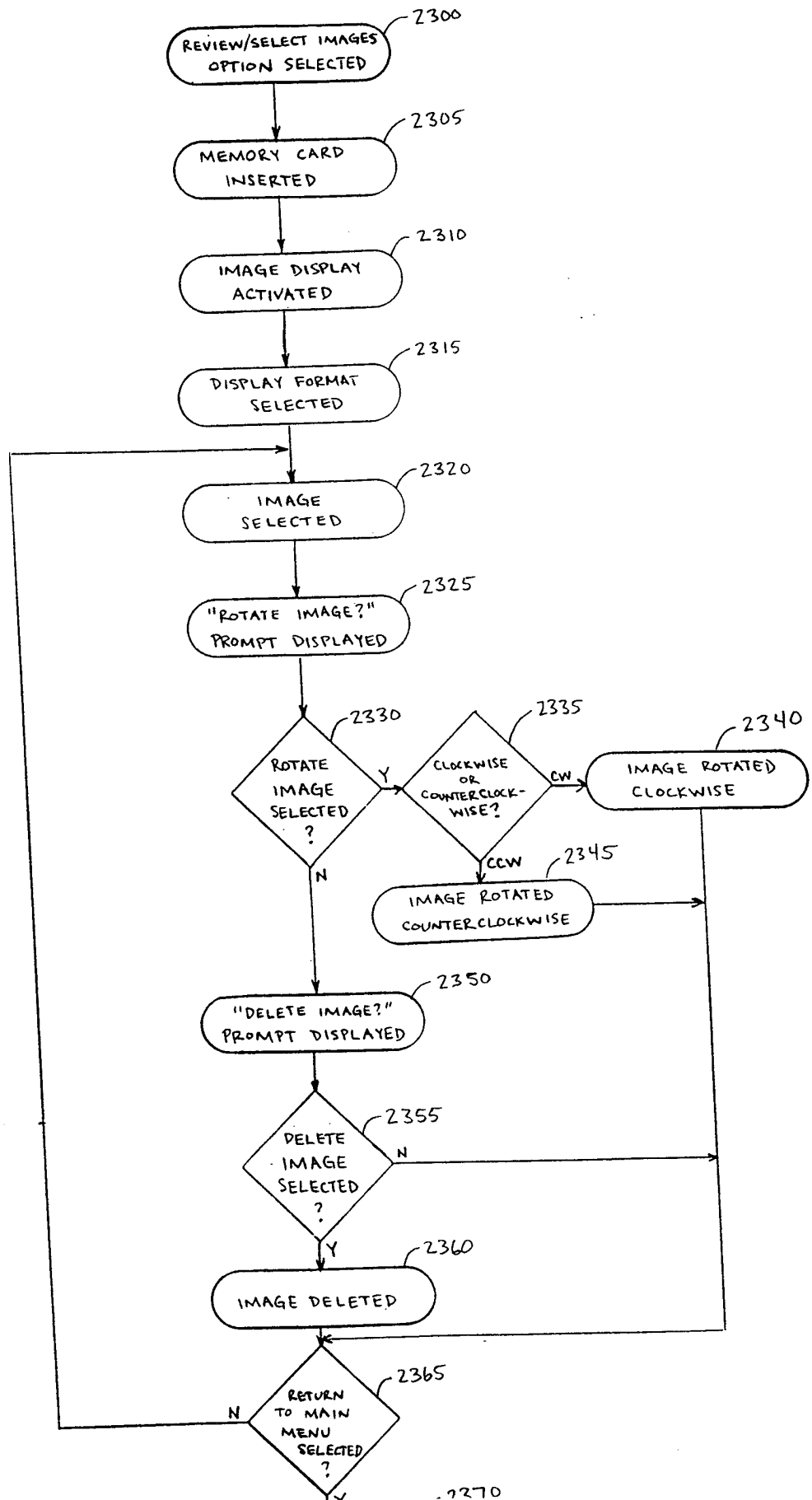

FIG. 20

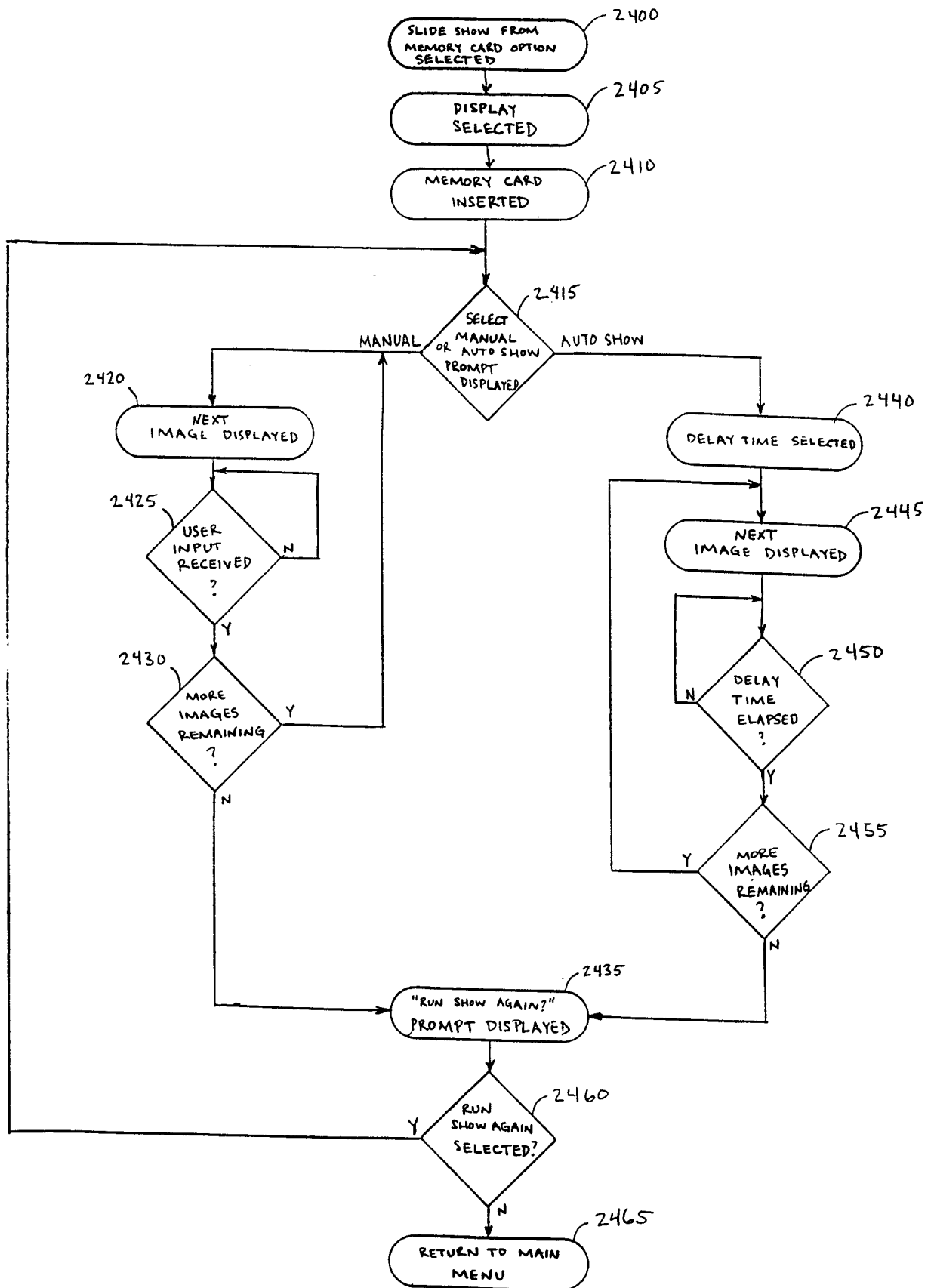

FIG. 21

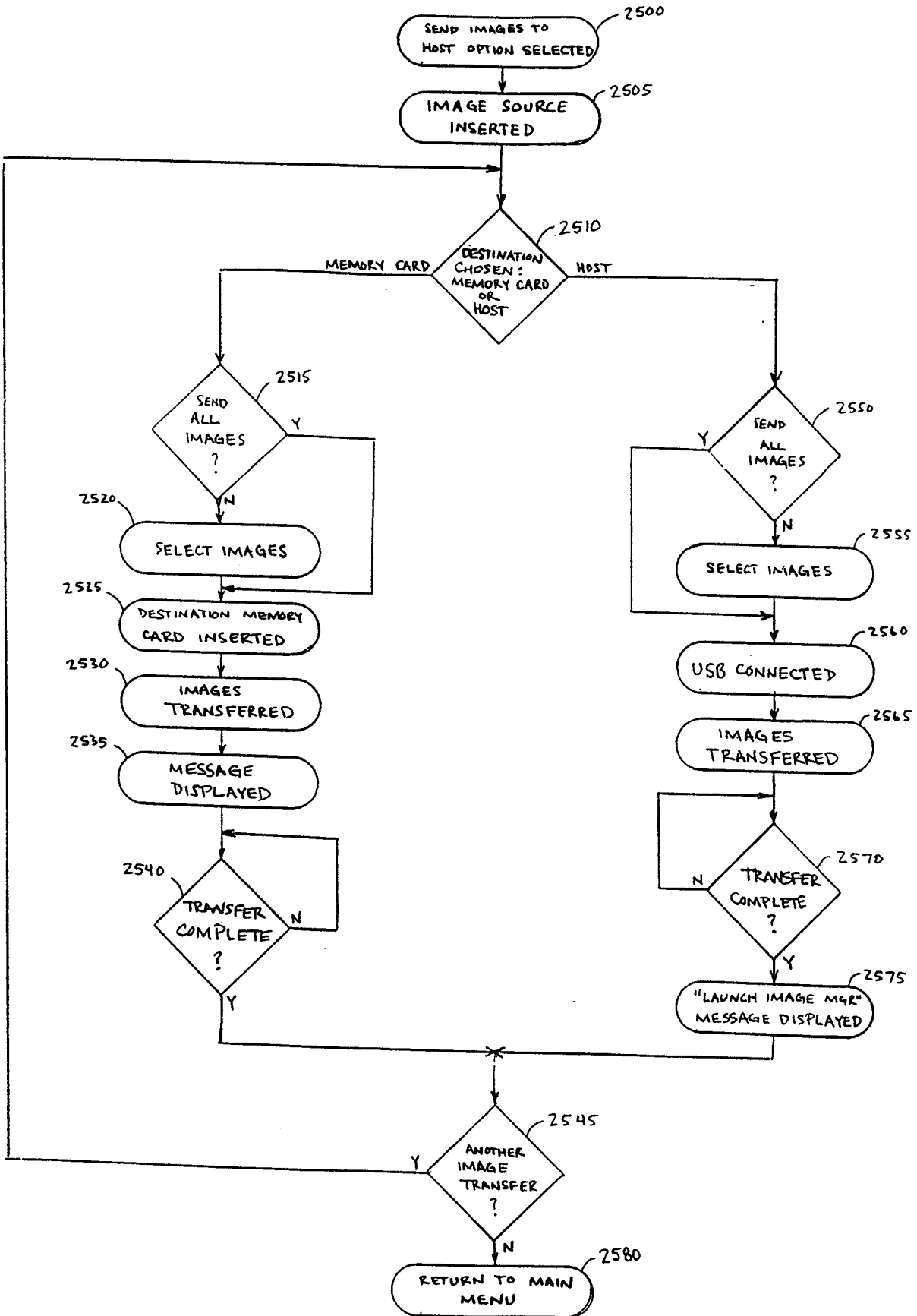

FIG. 22

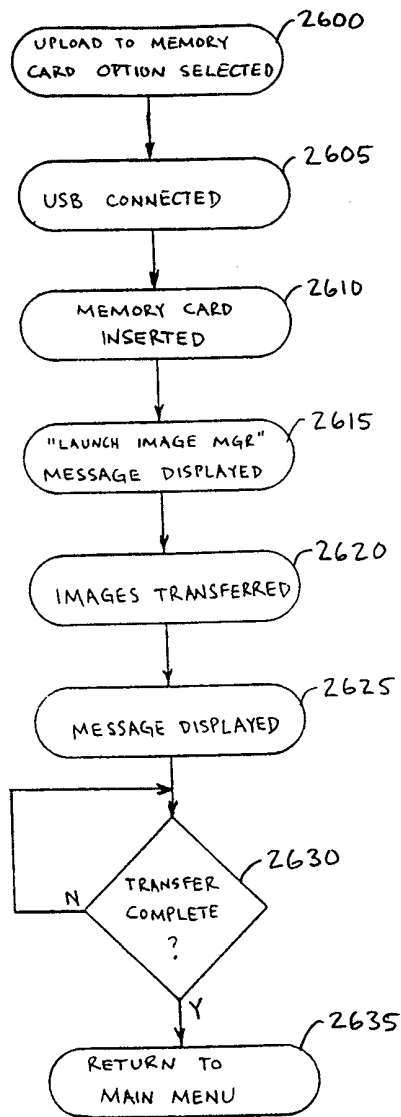

FIG. 23

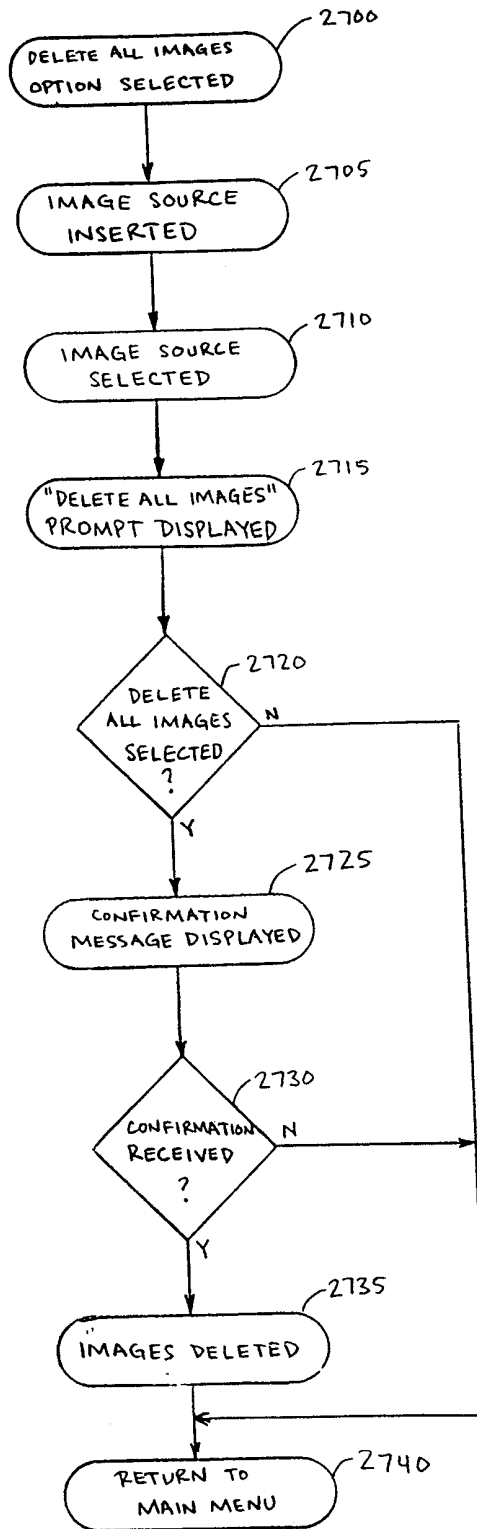

FIG. 24

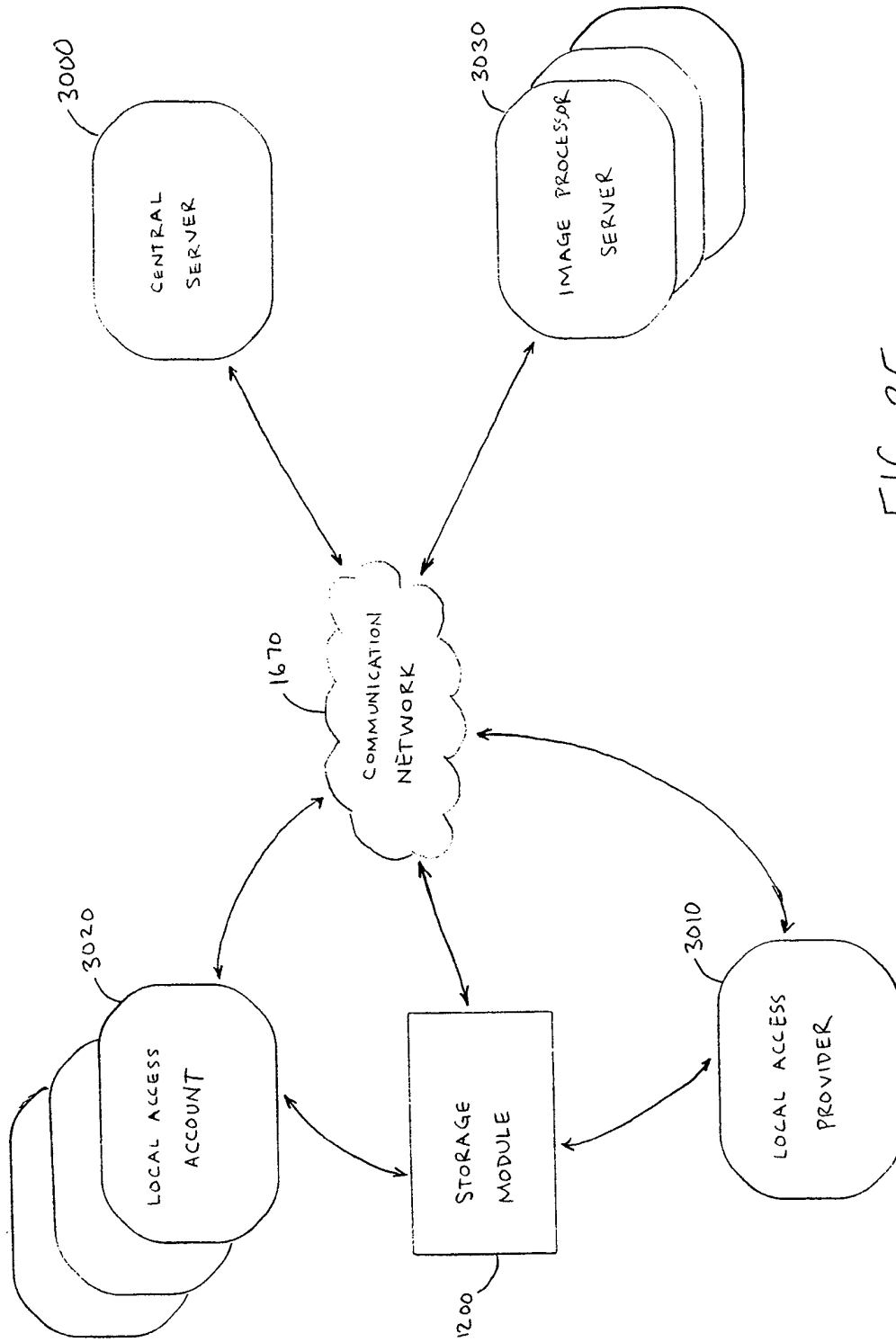

FIG. 25

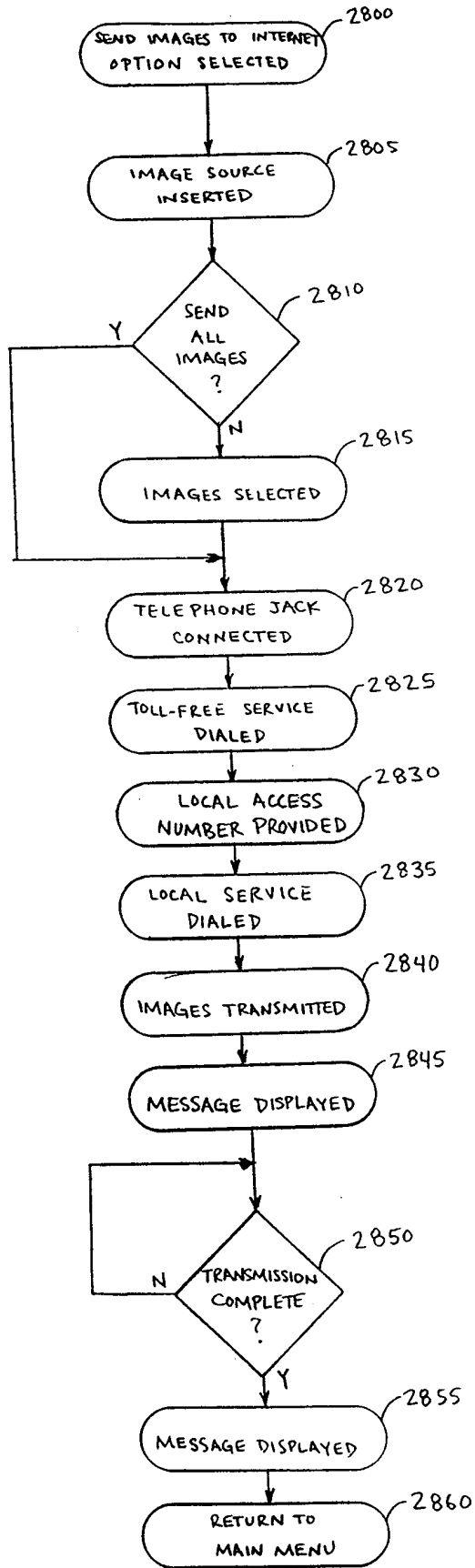

FIG. 26

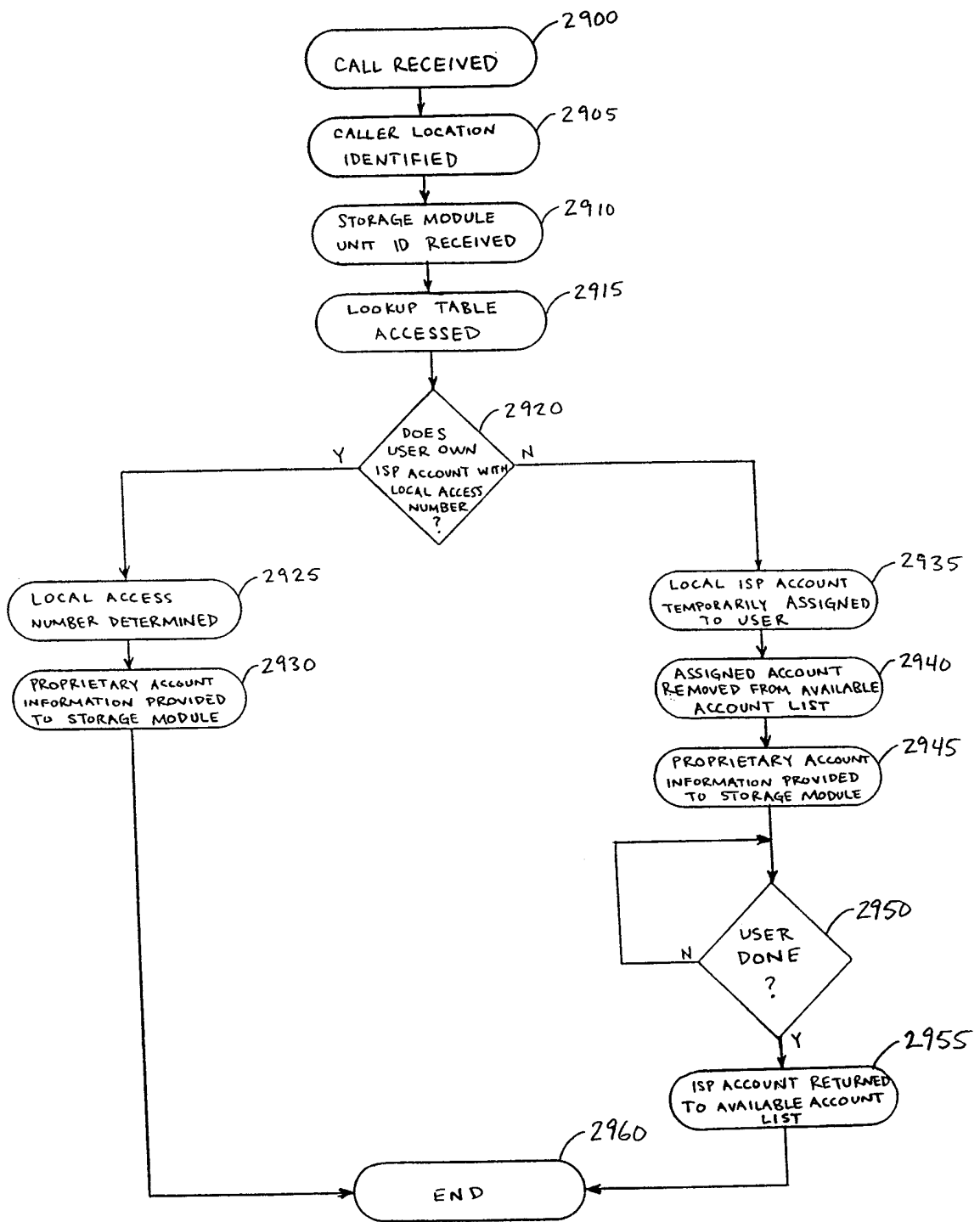

FIG. 27

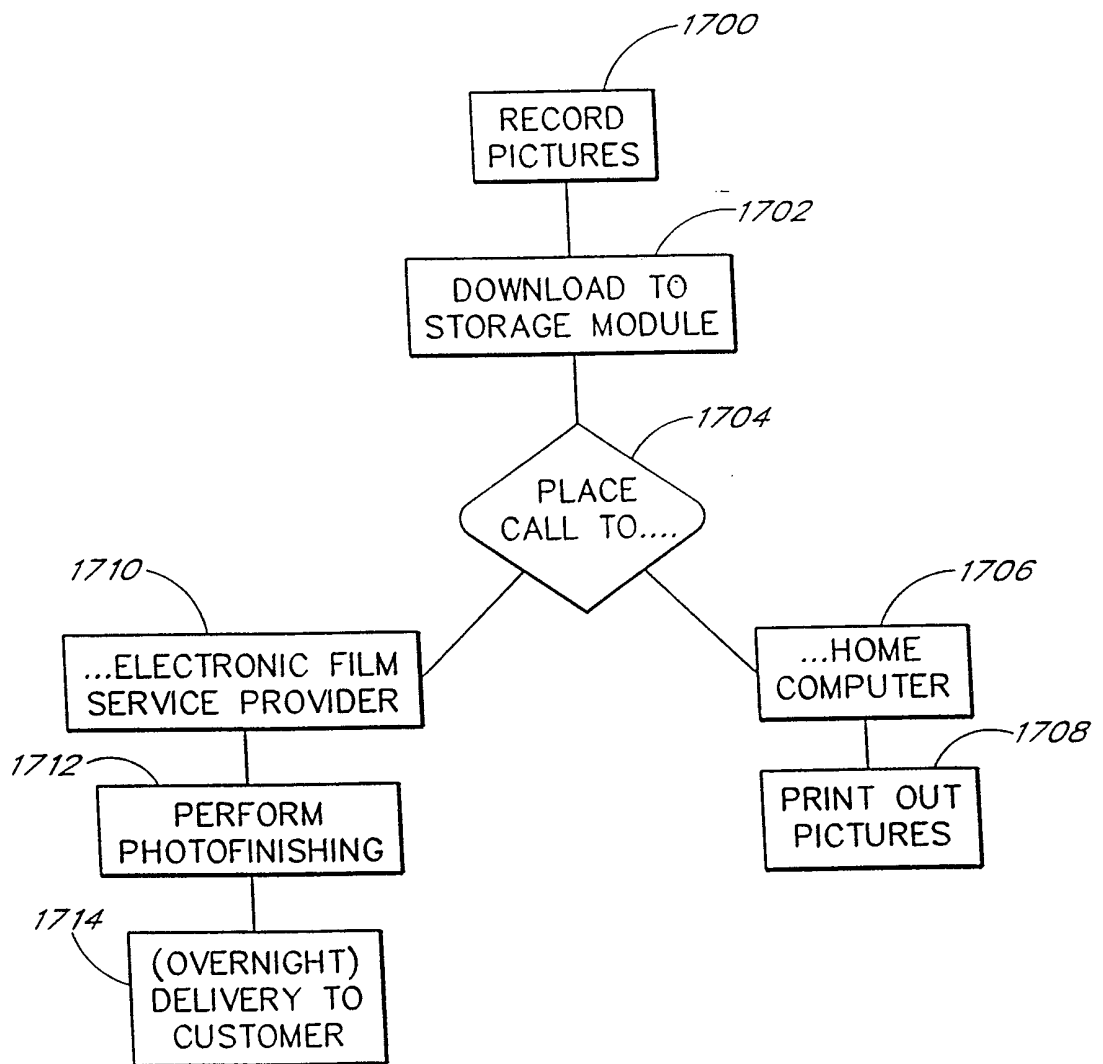

FIG. 28

