

(No Model.)

A. B. HERRICK.  
BUS BAR SWITCH FOR CENTRAL STATIONS.

No. 524,383.

Patented Aug. 14, 1894.

FIG. 1.

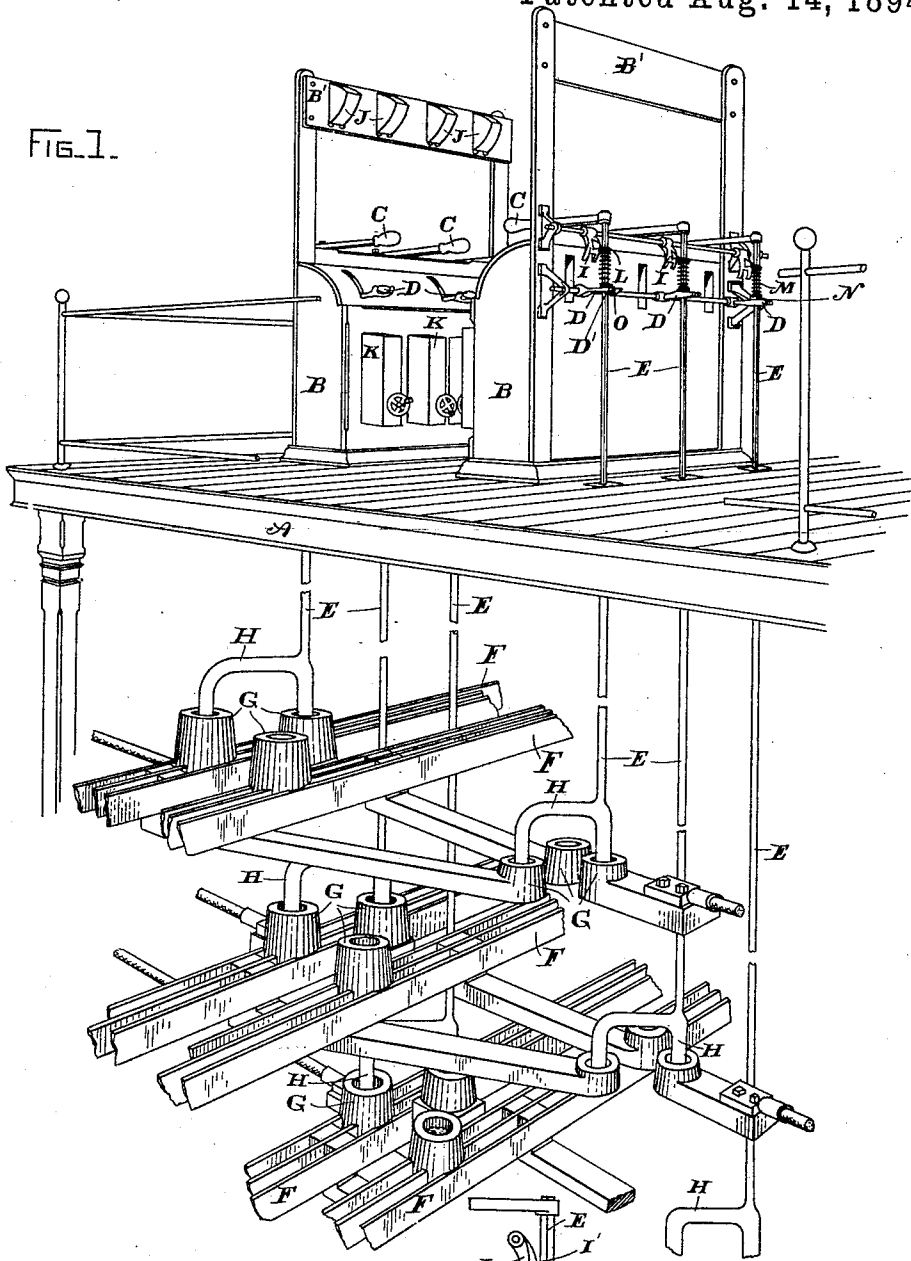

WITNESSES.

*A. F. Macdonald.*

*S. Johnston.*

FIG. 2.

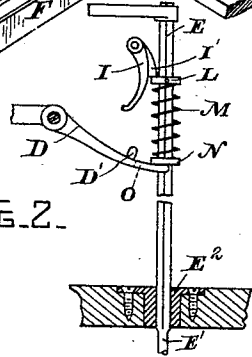

INVENTOR-  
*Albert B. Herrick*  
*Geo. W. Woodgett.*  
Att'y.

# UNITED STATES PATENT OFFICE.

ALBERT B. HERRICK, OF SCHENECTADY, NEW YORK, ASSIGNOR TO THE  
GENERAL ELECTRIC COMPANY, OF NEW YORK.

## BUS-BAR SWITCH FOR CENTRAL STATIONS.

SPECIFICATION forming part of Letters Patent No. 524,353, dated August 14, 1894.

Application filed June 9, 1894. Serial No 514,015. (No model.)

*To all whom it may concern:*

Be it known that I, ALBERT B. HERRICK, a citizen of the United States, residing at Schenectady, county of Schenectady, and State of New York, have invented certain new and useful Improvements in Bus-Bar Switches for Central Stations, of which the following is a specification.

My invention relates to means for switching heavy currents in central stations where a multiplicity of dynamos are operated, and the currents are carried to bus-bars in any usual and convenient manner. It is often a matter of convenience or necessity to shift the bus-bar connections, particularly where two or more potentials are employed in the same station, and it has been customary in large stations where the switch-boards were located in a gallery, to carry leads to these switch-boards which were capable of carrying the entire current generated and delivered to the bus-bars. In the case of large stations this becomes a serious cost, on account of the large amount of copper required, and it is also undesirable because it increases the length and resistance of the dynamo leads to the gallery and the feeders from the gallery, which should be kept as small as possible, as it involves constant waste of current. To obviate this expense, I have devised my present invention, which consists briefly in an improved arrangement of the gallery and the switches, whereby the connecting parts or poles of the switch are arranged adjacent to the bus-bars which are to be connected, while the entire operating system is assembled in the gallery at a convenient point, and the only connections necessary are those for the shunt field rheostat, the shunt ammeters, and the volt meters; the connection between the poles of the switches and the operating handles at the switch-boards being entirely mechanical, so that the waste of current and of copper pointed out is obviated. So serious is this waste and extra expense, that in a single instance in a large station, twenty-two tons of copper would have been necessary to convey all the current to the gallery and back, and the waste of current in this amount of copper together with the interest on its

cost, would be sufficient to pay six per cent. on a capital of sixteen thousand dollars.

My invention also includes certain details of construction more fully pointed out hereinafter.

The accompanying drawings show an embodiment of the invention, Figure 1 being a perspective showing the entire assembly, Fig. 2 being an enlarged detail.

A is the gallery, B, B the switch-boards which may be arranged in any convenient manner in the gallery.

C, C are the operating handles serving to turn the switches, and D, D are the handles serving to disengage the contacts of the switches by a snap action to be presently described.

E, E, &c., are the rods or other mechanical connections to the switches square or otherwise non-circular in form.

F, F are the bus-bars.

G, G, &c., are contacts for the switches which in the case illustrated are copper cups containing mercury, to insure good contact.

H, H are the contact points of the switch immersed in the mercury in the cups.

As shown, the switch consists of a bar of copper of U shape, its ends being in the cups.

I, I are detents or catches co-operating with the handle G to give a snap action to the switch. This part of the construction will be better understood by reference to Fig. 2.

Upon the rod E is fixed a collar L, and beneath the collar a coil spring M encircles the rod which has its bearing upon one end of the lever D; the end of the lever being bifurcated, as shown at O, passing on either side of the rod E, and supporting a loose collar N, which forms the bearing for the spring. Upon the dog or detent I is a lug I' engaging with a collar L. The lower part of the dog is also bifurcated, as shown in Fig. 1, and projections or lugs, D', D', upon the lever D engage with these lugs. A floor plate E<sup>2</sup> having a square hole is provided, through which the rod E, which is of square section, passes; at a point on the rod coincident with the floor plate E<sup>2</sup> when the switch is in its highest position, is a rounded portion E'. The operation of this part of the device is as follows:

When it is desired to turn one of the switches to change the connection of the bus-bars, the handle D is depressed, thus raising the bifurcated end O and pushing up the collar N, pressing the spring M until the lugs D', D' engage with the bifurcated end of the dog I, thus throwing the lug I' out of engagement with the fixed collar L and breaking the circuit of the switch H by the sudden snap action of the spring M forcing the rod E upward. When in its upper position with the contacts separated, the cylindrical portion E' of the rod E coincides with the opening in the floor plate or guide E<sup>2</sup>, and the handles C may then be moved horizontally to effect the new adjustment of position for the rod H. The handle D may then be lowered to position and the switch will be dropped so as to effect the new combination, whatever it may be. Upon the upper part of the switch-boards are indicated diagrammatically shunt ammeters and volt meters, J, J, and the shunt field rheostats are shown at K, K. These are the only parts of the gallery apparatus having electrical connection with the apparatus in the station, and as these convey but small current, they may be, as is well understood, supplied by small wire at but little cost.

What I claim as new, and desire to secure by Letters Patent of the United States, is—

1. A system of bus-bar switches for a central station comprising bus-bars, switches adapted to connect the bus-bars in different combinations, switch-boards located in a gallery, and mechanical connections between the switches on the bus-bars and the apparatus located upon the switch-boards in the gallery.

2. In a system of bus-bar switches for a cen-

tral station, bus-bars provided with switches, operating apparatus for the switches located in a gallery, mechanical connections between the switches and the gallery apparatus comprising rods E having operating handles adapted respectively to break the circuit and to change the circuit relations of the switches before re-establishing the circuit.

3. A switch adapted to change the relations of bus-bars in a central station, from a gallery or distant point, comprising a rod, a spring encircling the rod, a handle arranged to compress the spring against a collar fast to the rod, a detent engaging with the collar and maintaining the rod in position until the spring is compressed and to disengage the collar when the compressing handle touches the detent, and a second handle rotating the rod to change the circuit relations of the switch.

4. A switch adapted to change the relations of bus-bars in a central station, from a gallery or distant point, comprising a non-circular rod, a spring encircling the rod, a second handle rotating the rod to change the circuit relation of the switch, a guide having a non-circular hole adapted to fit the rod, and a cylindrical portion upon the rod adapted to register with the guide when the switch is in its raised position; whereby the switch is locked against rotation except when the circuit is broken.

In witness whereof I have hereunto set my hand this 6th day of June, 1894.

ALBERT B. HERRICK.

Witnesses:

B. B. HULL,

A. F. MACDONALD.