

June 13, 1961

C. CATALANO ET AL

2,987,771

MEANS FOR MAKING TEARING DOLLS

Filed July 23, 1958

3 Sheets-Sheet 1

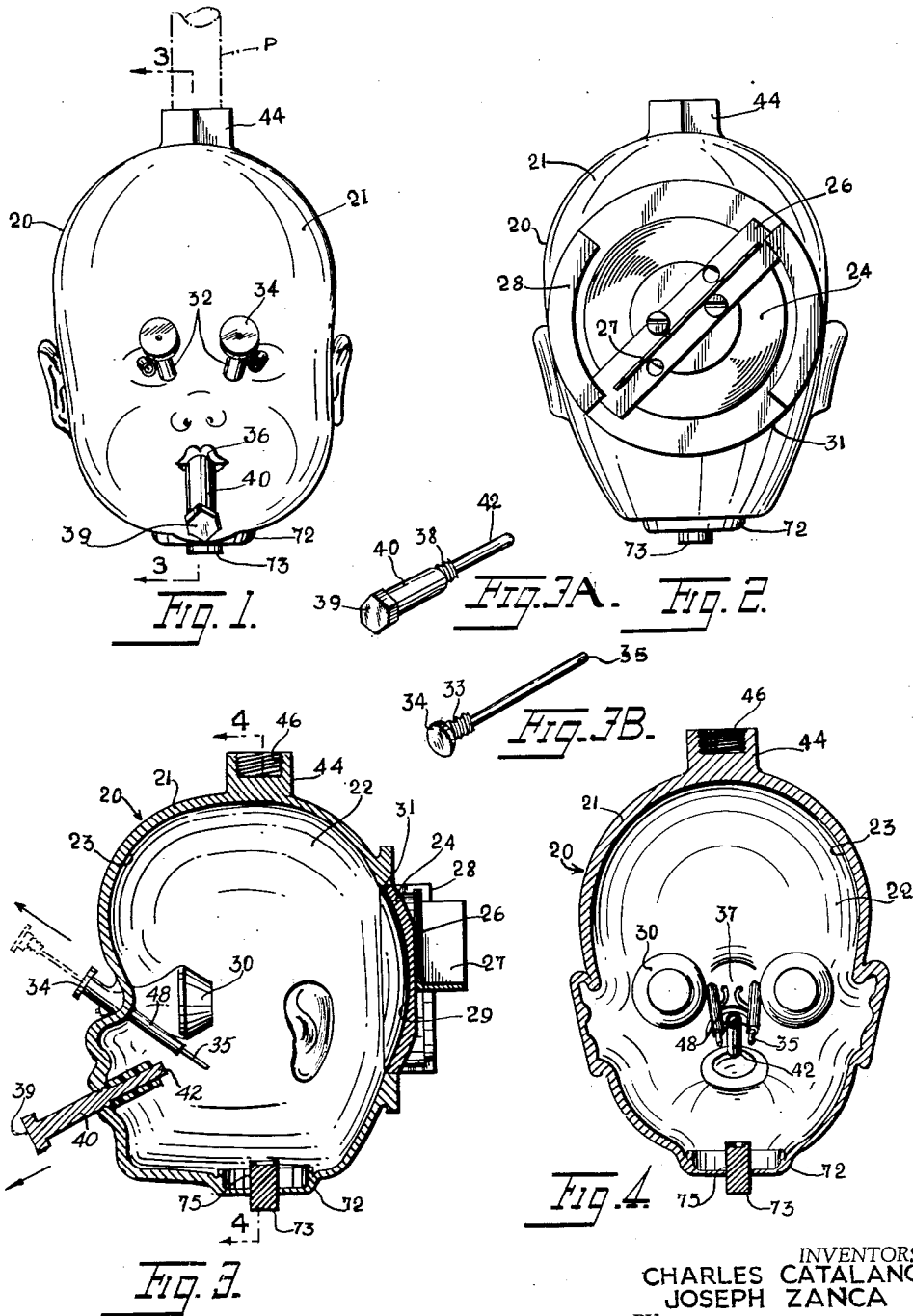

INVENTORS
CHARLES CATALANO
JOSEPH ZANCA

BY
John H. Polach
ATTORNEY

June 13, 1961

C. CATALANO ET AL

2,987,771

MEANS FOR MAKING TEARING DOLLS

Filed July 23, 1958

3 Sheets-Sheet 2

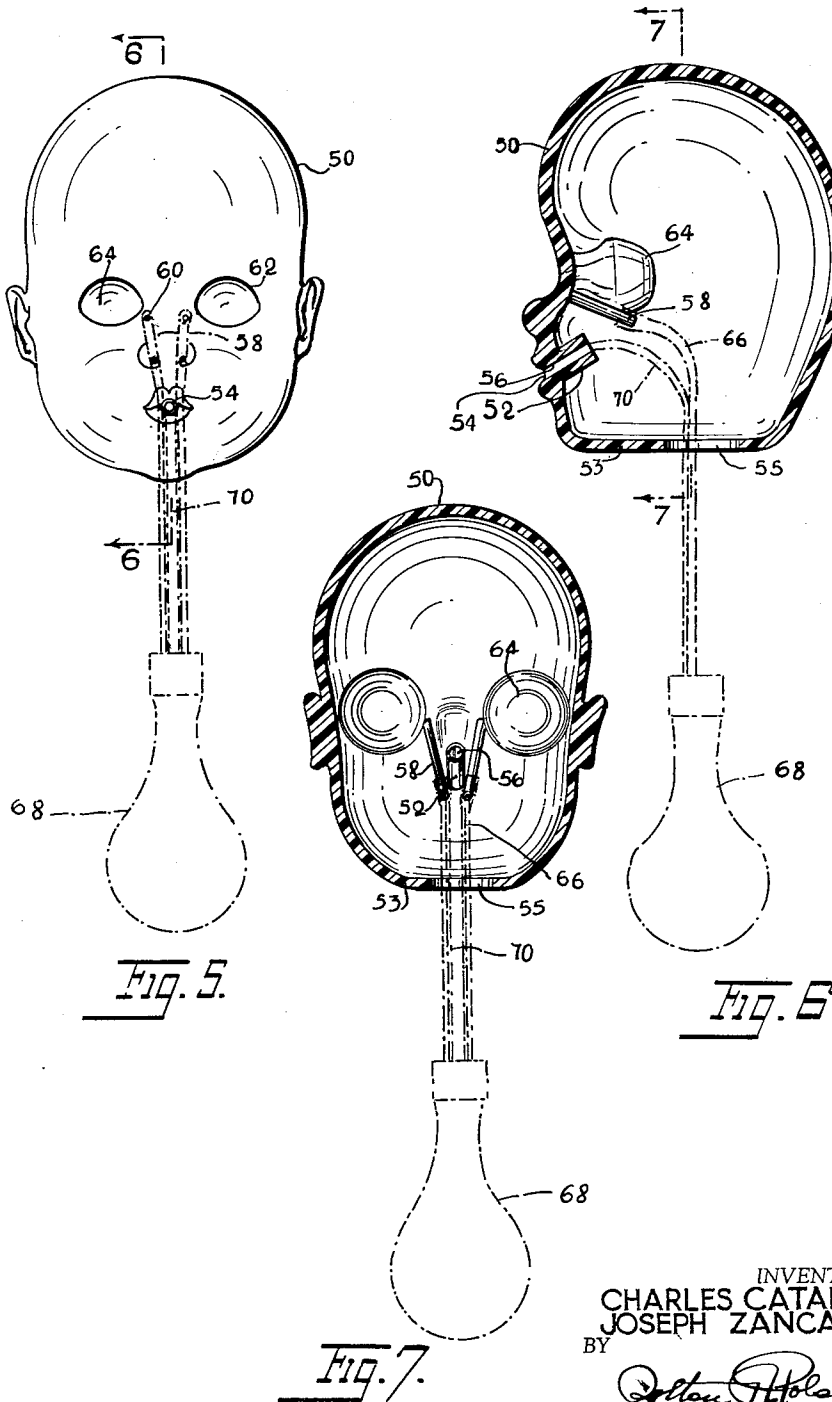

INVENTORS
CHARLES CATALANO
JOSEPH ZANCA
BY
John H. Holand
ATTORNEY

June 13, 1961

C. CATALANO ET AL

2,987,771

MEANS FOR MAKING TEARING DOLLS

Filed July 23, 1958

3 Sheets-Sheet 3

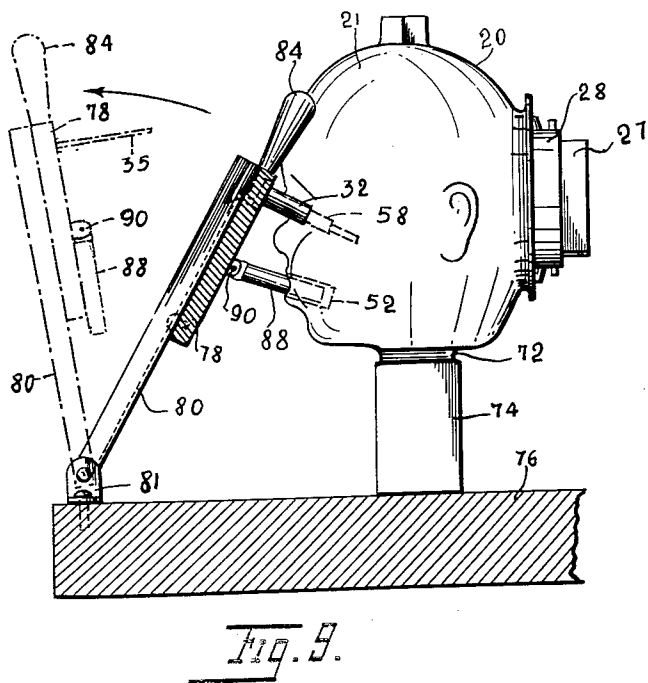
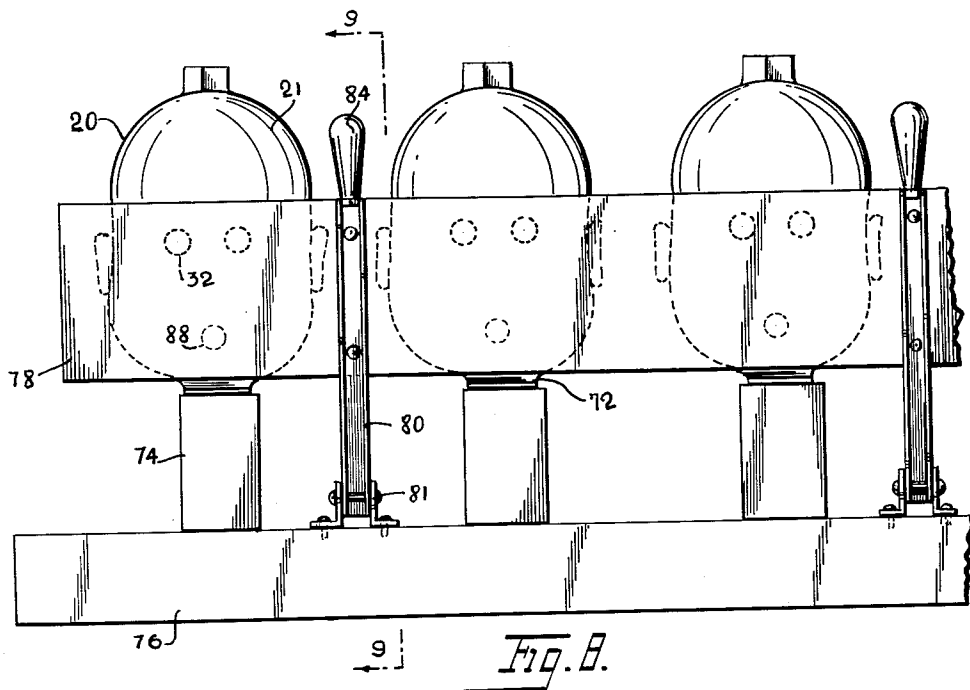

INVENTORS
CHARLES CATALANO
JOSEPH ZANCA
BY
John J. Holchek
ATTORNEY

1

2,987,771

MEANS FOR MAKING TEARING DOLLS

Charles Catalano, 98 Guernsey St., Brooklyn, N.Y., and Joseph Zanca, Brooklyn, N.Y.; said Zanca assignor to said Catalano

Filed July 23, 1958, Ser. No. 750,461

1 Claim. (Cl. 18—39)

This invention relates to the art of doll manufacture and particularly concerns a mold for manufacturing a doll's head.

Heretofore in the manufacture of rubber or plastic heads for dolls of the type which have movable eyes adapted to "weep" or shed "tears," it has been customary to provide a pair of eye sockets into which were inserted and cemented weep tubes which terminated in a rubber bulb. This bulb contained water which was supplied via another tube connected from the bulb to the mouth of the doll. The doll was fed with water via the mouth to fill the bulb. Upon squeezing the abdomen of the doll where the bulb was located, the water was discharged into the eye sockets to produce a simulated weeping effect.

Several difficulties were encountered by this prior construction. The passage of water into the eye sockets from the water reservoir provided by the bulb wetted the eyes and eye rolling mechanism. The mechanism consequently corroded and jammed; the eyelashes became loosened and fell off; and the water faded the painted pupils and irises of the eyes. Furthermore, it was never possible to reach the eye sockets to dry them out fully so that the internal continuously wet condition caused odors, mildew, etc.

The tube attachment at the mouth was also not satisfactory because there was an insecure attachment of the mouth tube to the mouth opening. Only a very small area at the end of the mouth tube could be cemented in the mouth opening. Frequent wetting and pressure on the mouth by a child loosened the mouth tube so that "feeding" became impossible and consequently "weeping" was precluded.

The present invention is directed at avoiding the foregoing difficulties and disadvantages by providing a novel mold for fabricating such a doll's head.

According to the invention, the openings for the weep tubes are located adjacent to the inner corners of the eyes but outside of the eye sockets. These openings are formed at the outlets of short stub tubes which are integrally molded into the head. A short stub tube is integrally molded at the mouth to which the usual mouth tube can be cemented to form a permanent joint. Thus the eyes and eye sockets remain dry while the doll is capable of a simulated weeping action which is most realistic in appearance.

It is therefore a principal object of the invention to provide a mold for forming a doll's head in which means are provided for forming integrally molded interior stub tubes adjacent the eye sockets, the tubes opening between the eyes and nose of the doll's head.

A further object is to provide a mold for forming a centrifugally cast flexible hollow doll's head, with removable plug inserts provided at the front face portion of the mold and extending inwardly adjacent the eye socket forming members.

A still further object is to provide a mold for forming a centrifugally cast flexible hollow doll's head, with three removable plug inserts provided at the front face portion of the mold and extending inwardly, one insert being located to form a stub tube at the mouth and the other two inserts being located between eye and nose forming portions to form further stub tubes.

Another object is to provide a means for molding a flexible doll's head with weep tubes disposed adjacent the eyes

2

in the head but separated therefrom and opening directly between the eyes and nose.

Another object is to provide a means for molding a flexible doll's head with stub weep tubes disposed adjacent the eye sockets in the head but separated therefrom and opening outwardly directly between the eyes and nose, and with a short inwardly extending stub tube for engaging a mouth tube.

For further comprehension of the invention, and of the objects and advantages thereof, reference will be had to the following description and accompanying drawings, and to the appended claims in which the various novel features of the invention are more particularly set forth.

In the accompanying drawings forming a material part of this disclosure:

FIG. 1 is a front elevational view of a mold embodying the invention.

FIG. 2 is a rear elevational view of the mold.

FIG. 3 is a sectional view taken on line 3—3 of FIG. 1.

FIG. 3A is a perspective view of an insert for forming the stub mouth tube.

FIG. 3B is a perspective view of an insert for forming a stub weep tube.

FIG. 4 is a sectional view taken on line 4—4 of FIG. 3.

FIG. 5 is a front elevational view of a doll's head formed according to the invention.

FIG. 6 is a sectional view taken on line 6—6 of FIG. 5.

FIG. 7 is a sectional view taken on line 7—7 of FIG. 6.

FIG. 8 is an elevational view of a plurality of molds embodying the invention provided with a multiple insertion and extraction means for mold pins.

FIG. 9 is a sectional view taken on line 9—9 of FIG. 8.

Referring to FIGS. 1—4, there is shown a metal mold 20 consisting of a front shell portion 21 having an inner surface 23 and an internal cavity 22 shaped in the desired form of the doll's head to be cast therein. A rear circular plate 24 has a crossbar 26 which is lockable in arcuate channel members 28 on the outside of the mold. Bar 26 is formed with a handle 27. The cover plate has an interior curvature or concavity 29 which smoothly continues the curvature of the inner surface 23. Cover 24 fits in opening 31 in member 21. At the front of the mold member 21 are two spaced bulbous members 30 which extend inwardly and are shaped to form eye sockets of the doll's head. Two spaced tubular bosses 32 are formed on the exterior of the mold and extend outwardly. These bosses are threaded to receive removable threaded portions 33 of plug inserts 34 best shown in FIG. 3B. These plug inserts each has a central pin or shaft 35 which extends into the cavity 22 in a downwardly directed position between eye socket forming members 30 and nose cavity 37. A threaded opening 36 is formed at the mouth of the mold. In this opening is removably threaded another plug insert 39 having a threaded portion 38 adjacent the shaft end 40. The other end 42 is a smooth cylindrical pin of reduced diameter which extends inwardly into the cavity 22. At the top of the mold is a boss 44 formed with a threaded recess 46. This recess serves to engage a post P indicated by dotted lines in Fig. 1. The post is part of a rotatable support (not shown) for the mold when it is used in a centrifugal casting machine. A suitable machine for this purpose is described in Patent 2,573,693 to G. W. De Bell.

In use of the mold, a certain measured quantity of a thermoplastic or thermosetting material in liquid or paste form is inserted into the cavity 22. Two small flexible plastic tubes 48 are fitted snugly on the pins 35. Cover 24 is closed and locked in place by turning handle 27 to engage bar 26 in flanges 28. The mold is then placed in the centrifugal casting machine if it is not already mounted there and is rotated and oscillated until the plastic material covers the interior surfaces 23, 29, pins

35, 42, and all inwardly extending members within the cavity 22. The mold will be heated during processing. If the plastic material is thermosetting, the heat will set the plastic. If the material is thermoplastic, the applied heat will keep it sufficiently fluid until a uniform thickness of plastic is deposited within the mold. The temperature of the applied heat will then be lowered until the material sets whereupon rotation and oscillation will be stopped and the mold cover 24 may be opened. The inserts 34 and 39 will be then removed. The set material may then be extracted from the wide opening 31 in which the cover is fitted. The set material will then have the form of a doll's head 50 as shown in FIGS. 5-7.

The doll's head 50 conforms in shape exactly to the interior surfaces and inwardly projecting members of the mold. A stub tube 52 will be formed at the mouth opening 54. When the head is first extracted from the mold this tube will have a closed inner end which will have to be cut off to provide a passage 56 through the tube. Stub tubes 58 will extend inwardly from the weep openings 60. These weep openings are located adjacent the inner corners of eye socket openings 62 in the front of the head 50. The short tubes 43 which were initially fitted over pins 35 have become embedded in and integral with the new stub tubes 58. The ends of stub tubes 58 must be cut off to provide continuous passages therethrough from openings 60. The tubes 58 may be found to have a common wall with eye sockets 64. This structure is desirable since it will strengthen the tubes for supporting the connecting tubes 66 shown in dotted lines in FIGS. 5-7. These tubes 66 fit snugly over tubes 58 and may be cemented thereto. The tubes 66 terminate at rubber bulb 68. Another tube 70 will be connected between bulb 68 and tube 52. Tube 70 will fit in and may be cemented to the stub tube 52 which provides a sufficient support so that tube 70 does not become detached therefrom.

It will be noted that the bulb 68 may be filled with water via tubes 52 and 70 which will then be ejected in a very fine stream or as individual drops from each weep opening 60 when the bulb 68 is pressed. To prevent the water from leaving the bulb through tube 70 there will be provided a suitable valve (not shown) constructed in a manner well known in the art.

The mold 20 has a bottom neck portion 72 having a hole 75 in which is removably inserted a pin or screw 73 and by means of which hole the mold can be filled with fluid plastic material. This neck portion and pin can also serve as an alternative mounting means for the head instead of boss 44 in a centrifugal casting machine.

After the head 50 is removed from the mold, part of the resulting closed bottom portion 53 shown in FIGS. 6 and 7 will be cut away to form the neck opening 55 through which the several tubes 66 and 70 will be passed.

While any suitable material may be used in forming the doll heads 50, plastics generally known as plastisols have proven most adaptable for the centrifugal casting process contemplated for use in the molds. A suggested plastic mix employs vinyl chloride acetate in unplasticized form, dioctyl phthalate as plasticiser, and various mineral pigments. The interior of the mold may be lightly coated with a silicone parting compound to insure ready separation of the set plastic from the mold.

In FIGS. 8 and 9 is shown a plurality of molds 20 in which their neck portions 72 are secured and supported on posts 74 mounted on a bar 76. Bar 76 is part of a centrifugal casting machine of the type mentioned above which rotates and oscillates the molds as a group. Each of the pin inserts 35 is secured at its outer end to a plate 78 which is supported on arms 80 pivotally mounted by

brackets 81 on bar 76. Pins 35 are somewhat flexible so that they can be inserted in bosses 32. In FIG. 9 is shown the tubular coating 58 formed on pins 35 and the reinforcement tubes 48 best shown in FIGS. 3 and 4. A handle 84 is attached to each arm 80 for pivoting plate 78 away from the molds and simultaneously extracting all the pins 35 as indicated by the arrow in FIG. 9.

The plate 78 also carries a plurality of pins 88 pivotally mounted on hinge elements 90. These pins are all inserted through the mouth openings in the molds, and after tubular coatings 52 are formed thereon all the pins 88 are simultaneously removed from the molds together with pins 35.

While we have illustrated and described the preferred embodiments of our invention, it is to be understood that we do not limit ourselves to the precise constructions herein disclosed and that various changes and modifications may be made within the scope of the invention as defined in the appended claim.

Having thus described our invention, what we claim as new, and desire to secure by United States Letters Patent is:

A mold device for manufacturing dolls' heads, comprising a horizontal rotatable bar, a plurality of posts secured upright to said bar in spaced positions therealong, a plurality of metal shells mounted on the respective posts, each of said shells having a vertical wall with an opening therein, a cover removably disposed in each of the openings, each of said shells having an inner surface formed with a reverse configuration of features of a doll's head, each shell having inwardly extending spaced bulbous members for forming eye sockets in the head, a pair of spaced tubular bosses formed on the exterior of said shell opposite to said wall and communicating with the interior of the shell, said shell having a portion defining a mouth opening, a plate extending parallel to said bar, a plurality of arms carrying said plate and pivotally mounted on said bar to swing the plate on a horizontal axis toward and away from the shells, a plurality of flexible pins carried by the plate and removably inserted axially in said bosses and extending into the interior of the shells, and a plurality of other pins pivotally carried by said plate and inserted through the mouth openings in the shells into the interiors thereof, all of the pins being withdrawn from the shells simultaneously when the plate is pivoted away from the shells, whereby said dolls' heads are formed on the inner surfaces of the shells when the bar is rotated while the shells containing predetermined quantities of plastic material are heated so as to set the plastic, said plastic setting on portions of the pins inserted in the interiors of the shells and forming tubes therein when the pins are simultaneously withdrawn.

References Cited in the file of this patent

UNITED STATES PATENTS

2,263,720	Carlo	Nov. 25, 1941
2,352,083	Detjen	June 20, 1944
2,391,131	Clark	Dec. 18, 1945
2,629,134	Molitor	Feb. 24, 1953
2,691,190	Bethe et al.	Oct. 12, 1954
2,728,948	Kallus	Jan. 3, 1956
2,730,765	Crafton et al.	Jan. 17, 1956
2,763,031	Reketye	Sept. 18, 1956
2,804,653	Talalay	Sept. 3, 1957
2,830,325	Bray	Apr. 15, 1958
2,923,032	Miller et al.	Feb. 2, 1960
2,929,104	Hutton	Mar. 22, 1960