



EUROPEAN PATENT APPLICATION

Application number: 83305822.5

Int. Cl.<sup>3</sup>: E 04 G 1/00, E 04 G 1/28,  
E 04 G 1/36

Date of filing: 28.09.83

Priority: 06.11.82 GB 8231749

Applicant: W.B. Black & Sons (Holdings) Limited, Kings  
Inch Road, Renfrew PA4 8XU Scotland (GB)

Date of publication of application: 13.06.84  
Bulletin 84/24

Inventor: Black, William Brown, "Penwold" Kilbarchan  
Road, Bridge of Weir Scotland (GB)

Designated Contracting States: AT BE CH DE FR GB IT  
LI LU NL SE

Representative: Arthur, John William et al,  
FITZPATRICKS 4 West Regent Street, Glasgow G2 1RS  
Scotland (GB)

Scaffolding.

A modular block is the key component of scaffolding for use in restricted working spaces such as are encountered in the building of coke ovens.

The scaffolding comprises a plurality of columns (8) spaced at regular intervals along the length of the working space (9) and each built up from a set of modular blocks (12 to 15). The modular blocks are preferably of a framed construction, injection moulded from a high-density thermoplastic polymer, and structured to give high resistance to crushing. The blocks (12 to 15) of each set are all of the same external transverse horizontal dimensions and each is fashioned at its underside with a depending peripheral flange (16) and at its upper side with an inset peripheral ledge (17). The modular blocks (12 to 15) of each set differ in flange and ledge widths with the ledge width of each greater than the flange width and the peripheral flange (16) of each upper block (13, 14 and 15 respectively) in a column (8) snugly fitting on to the peripheral ledge (17) of the block (12, 13 and 14 respectively) immediately therebelow in the column.

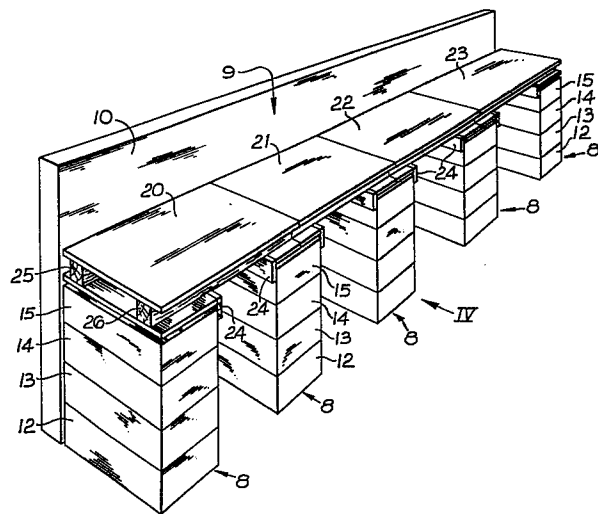

SCAFFOLDING

This invention relates to scaffolding, and more especially to scaffolding for use in restricted working spaces such as are encountered in the building of coke ovens.

It has hitherto been customary in the building of coke ovens to use scaffolding of the kind comprising spaced parallel skeletal frames made up of two vertical tubular poles or risers interspaced by transverse tubular poles or ledgers, successive frames being mutually tied by cross and diagonal tubular poles bridging therebetween, and a working platform being provided by timber battens supported on corresponding transverse poles or ledgers of the frames.

Scaffolding of the kind aforesaid has to be erected by a recognised scaffolding organisation within the limits of their standard products and the adaptability thereof is limited. It can be erected only in lifts or levels dictated by lengths of vertical poles or risers between transverse poles or ledgers of standard frames and building or construction work is interrupted while new lifts or levels are installed. Scaffolding of the kind aforesaid cannot be made totally stable in itself in coke oven constructions, because of the restricted working space, and requires additional shoring to walls by putlogs as they are being built. Moreover, the working platform has to be formed from standard scaffold boards nine inches in width and this frequently leaves a gap within the oven wall space, with a consequent safety problem.

The object of the present invention is to provide scaffolding for use in restricted working spaces which does not have the disadvantages implicit in the preceding paragraph of scaffolding of the kind aforesaid.

In accordance with the present invention scaffolding for use in a restricted working space is characterized in that the working platform is supported on columns spaced at intervals lengthwise of the restricted  
5 working space and each built up from a set of modular blocks all of the same external transverse horizontal dimensions and each fashioned at its underside with a depending peripheral flange and at its upper side with an inset peripheral ledge, the modular blocks of each  
10 set differing in flange and ledge widths with the ledge width of each greater than the flange width and the peripheral flange of each upper block snugly fitting on to the peripheral ledge of the block immediately there-  
below in the respective column.

15 An embodiment of the invention will now be described, by way of example, with reference to the accompanying drawings, wherein:

Fig. 1 is a perspective view from above and to one side and end of scaffolding in accordance with the  
20 invention;

Fig. 2 is an end elevation on a smaller scale of the scaffolding of Fig. 1;

Fig. 3 is a transverse vertical sectional view on yet another scale, through the lower part of one of the  
25 columns of the scaffolding; and

Fig. 4 is an end elevation, in the direction of the arrow IV of Fig. 1, looking on to an intermediate column of the scaffolding and showing part of the working platform and its substructure.

30 Referring now to the drawings, the scaffolding comprises a plurality of columns (8) (five in the embodiment shown) spaced at regular intervals along the length of the working space (9) between walls (10) and (11) of a coke oven under construction. Each column (8)  
35 is built up from a set of modular blocks denoted (12) to

(15) in the upwards direction. While there are four modular blocks in each column in the drawing, it will be manifest that the number thereof will increase as construction work progresses. The modular blocks (12) to (15) are of a framed construction and are injection moulded from a high-density thermoplastic polymer material and structured to give high resistance to crushing. The blocks (12) to (15) are all of the same external transverse horizontal dimensions and each is fashioned at its underside with a depending peripheral flange (16) and at its upper side with an inset peripheral ledge (17), the modular blocks (12) to (15) of each set differing in flange and ledge widths with the ledge width of each greater than the flange width and the peripheral flange of each upper block (13), (14) and (15), respectively in a column (8) snugly fitting on to the peripheral ledge of the block (12), (13) and (14), respectively, immediately therebelow in the column.

The working platform is made up of rectangular boards (20), (21), (22) and (23) of width the full length of the columns (8), i.e. the transverse horizontal dimension of the latter widthwise of the working space (9). The lengths of the boards (20 to 23) are dictated by the widths of the columns, i.e. the transverse horizontal dimension of the latter lengthwise of the working space (9), and the spacing between the columns (8), the end boards (20) and (23) being of length to extend from the outer face of the respective end columns (8) to midway across the respective adjacent column (8) and the intermediate boards (21 and 22) being of length to extend from midway across a respective intermediate column (8) to midway across an adjacent intermediate column (8).

Each of the boards (20 to 23) is strengthened at its underside by two rectangular-section beams or bars (25) and (26) of the full length of the respective individual board, the beams or bars (25 and 26) being spaced somewhat inwardly of and extending parallel to the respective sides of the individual boards. The boards (20 to 23) are screwed or bolted to the beams or bars (25 and 26). Base boards (27) of the same areal dimensions as the columns (8) are screwed to the undersides of the beams or bars (25 and 26) flush with the ends of the latter and at appropriate intervals therealong to match the intervals between adjacent columns (8), the base boards (27) to be seated on the intermediate columns (8) being halved longitudinally with the respective halves 27A and 27B (Fig. 4) flush with the respective ends of the beams or bars (25 and 26). Strips 24 of the same length as the base boards 27 are screwed to the sides of the latter to depend on edge from the bars or beams 25 and 26 and flank the upper ends of the columns when the working platform is set down thereon. It will be noted from Fig. 1 that strips 24 are not provided at the extreme ends of the platform substructure. The platform is securely locked at each of its ends to the permanent steel support structure of the coke oven in order to inhibit any tendency of the scaffolding to lean in the direction of its length.

There is normally no necessity for locking the columns (8) to the floor but this could readily be effected, if required.

When the working platform is to be raised to a new level, it is simply lifted from the columns (8) and the height of the latter increased by the addition thereto of further modular blocks with flanges 16 and ledges 17 of appropriate widths, whereupon the platform is again set down thereon.

CLAIMS

1. Scaffolding for use in a restricted working space, characterized in that the working platform is supported on columns (8) spaced at intervals lengthwise of the restricted working space (9) and each built up from a set of modular blocks (12 to 15) all of the same external transverse horizontal dimensions and each fashioned at its underside with a depending peripheral flange (16) and at its upper side with an inset peripheral ledge (17), the modular blocks (12 to 15) of each set differing in flange and ledge widths with the ledge width of each greater than the flange width and the peripheral flange (16) of each upper block snugly fitting on to the peripheral ledge (17) of the block immediately therebelow in the respective column (8).

2. Scaffolding as claimed in claim 1, characterized in that the modular blocks (12 to 15) are of a framed construction and are injection moulded from a high-density thermoplastic polymer material and structured to give high resistance to crushing.

3. Scaffolding as claimed in claim 1 or 2, characterized in that the working platform set up on the columns (8) comprises rectangular boards (20 - 23) of width equivalent to the transverse horizontal dimension of the column widthwise of the working space and of length such that when juxtaposed end-to-end the boards extend between the mutually-remote faces of the end columns, each of said boards being secured to and strengthened at its underside along its full length by spaced and parallel rectangular-section beams or bars (25 and 26), and a substructure secured to the undersides of said bars or beams (25 and 26) and including means locating on the upper ends of the individual columns.

4. Scaffolding as claimed in claim 3, characterized in that the end ones (20 and 23) of the juxtaposed boards and the beams or bars (25 and 26) secured thereto extending fully across the respective end  
5 column (8), across the gap between the latter and the adjacent intermediate column (8), and midway across the latter, and the intermediate ones (21 and 22) of the juxtaposed boards and the beams or bars (25 and 26) secured thereto extending across the gap  
10 between two adjacent intermediate columns (8) and midway across each of the latter.

5. Scaffolding as claimed in claims 3 and 4, characterized in that said substructure comprises base boards (27) of areal dimensions similar to the  
15 columns (8) secured to the undersides of, and flush with the outer ends of, the beams or bars (25 and 26) strengthening each end platform board (20, 23), and base boards (27A and 27B) of half the areal dimensions of the columns (8) secured to the undersides  
20 of, and flush with the inner ends of, the beams or bars (25 and 26) strengthening each end platform board (20, 23) and secured to the undersides of, and flush with each end of, the other bars or beams (25 and 26), and strips (24) secured to inner transverse edge of  
25 each end base board (27) and of each half-size base board (27A, 27B) and depending on edge from the respective pairs of beams or bars (25 and 26) to flank the columns (8) at the upper ends of the latter.

6. Scaffolding as claimed in claim 3, 4 or 5,  
30 characterized in that the working platform is securely locked at each of its ends to permanent support structure at the ends of the restricted working space.

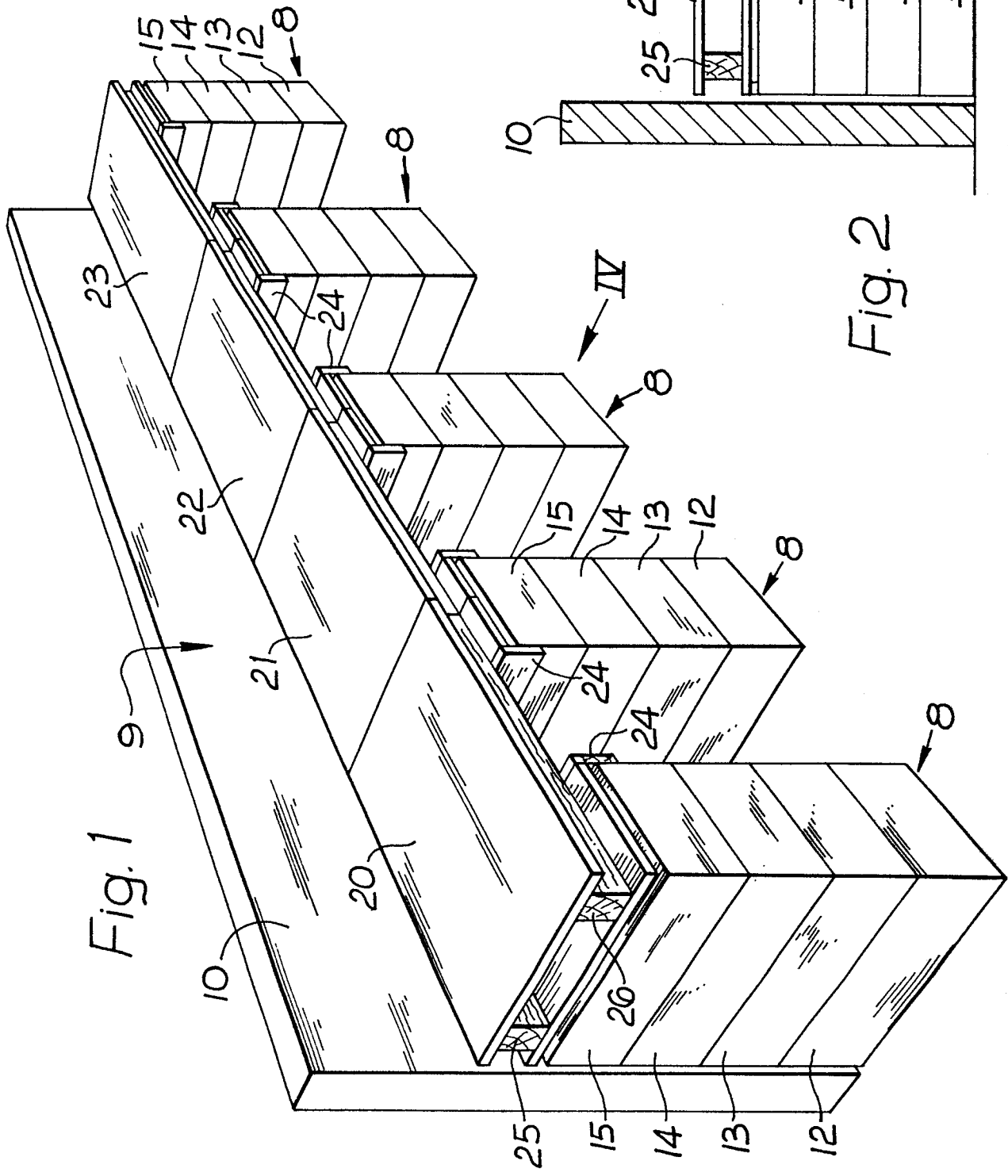

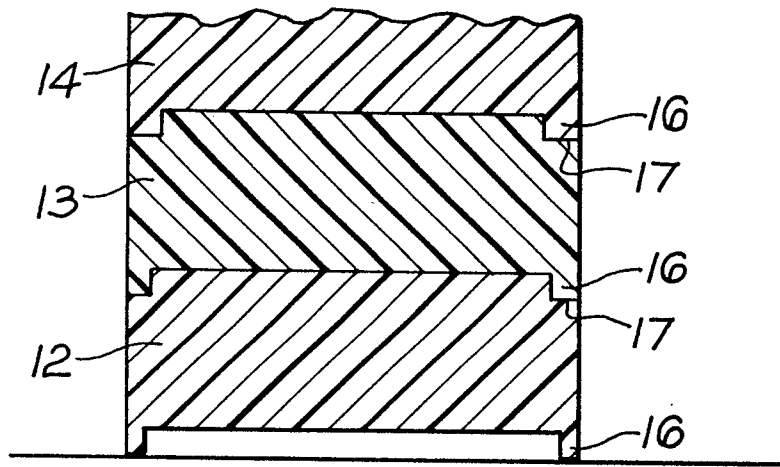

Fig. 3

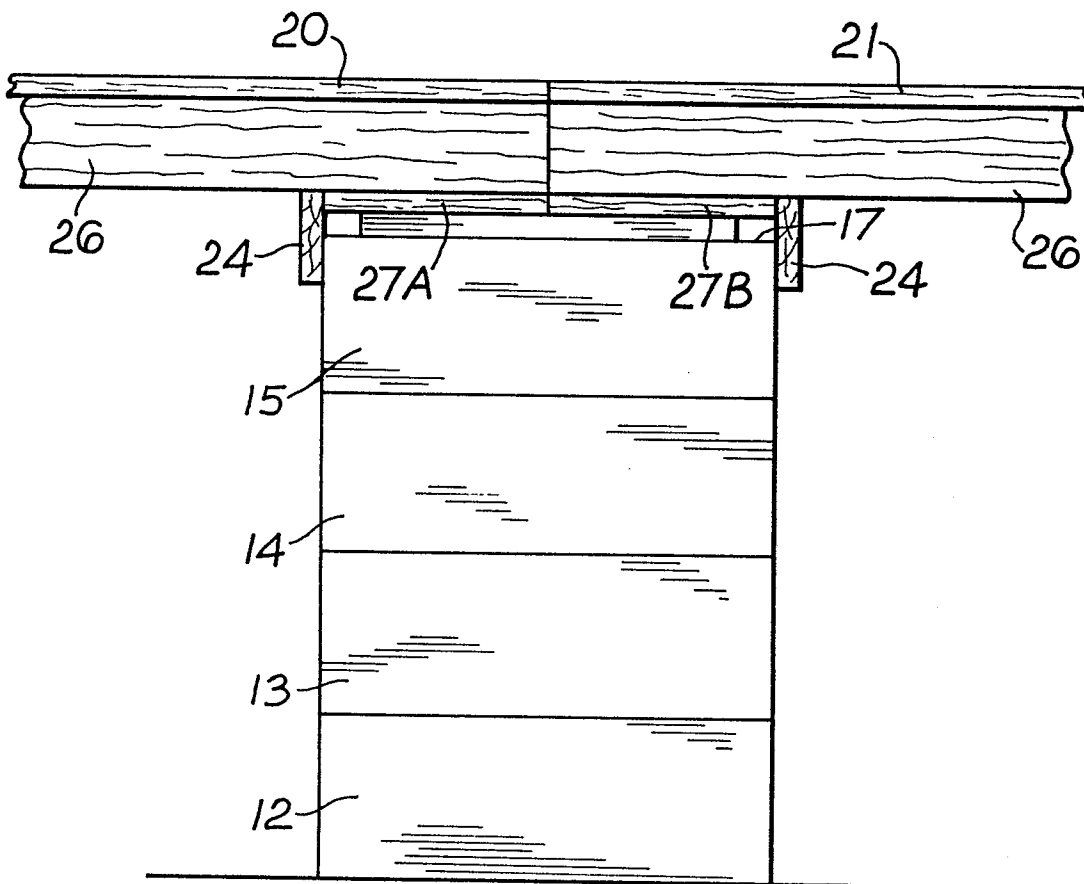

Fig. 4