

(19) World Intellectual Property Organization
International Bureau



(43) International Publication Date
17 July 2003 (17.07.2003)

PCT

(10) International Publication Number
WO 03/058308 A2

(51) International Patent Classification⁷: **G02B 6/16**

(21) International Application Number: PCT/GB03/00060

(22) International Filing Date: 10 January 2003 (10.01.2003)

(25) Filing Language: English

(26) Publication Language: English

(30) Priority Data:
0200603.9 11 January 2002 (11.01.2002) GB
0207240.3 27 March 2002 (27.03.2002) GB
0210933.8 15 May 2002 (15.05.2002) GB

(71) Applicant (for all designated States except US): **BLAZE PHOTONICS LIMITED** [GB/GB]; Finance Office, University of Bath, The Avenue, Claverton Down, Bath BA2 7AY (GB).

(72) Inventors; and

(75) Inventors/Applicants (for US only): **RUSSELL, Philip,**

St. John [GB/GB]; Shepherd's Mead, Southstoke, Bath BA2 7EB (GB). **BIRKS, Timothy, Adam** [GB/GB]; 14 Horsecombe Brow, Combe Down, Bath BA2 5QY (GB). **KNIGHT, Jonathan, Cave** [GB/GB]; Canteen Cottage, Canteen Lane, Wellow, Bath BA2 8PY (GB). **SABERT, Hendrik** [GB/GB]; Flat 2, 119 Broadhurst Garden, London NW6 3BJ (GB). **JONES, Julian** [GB/GB]; 161 Englishcombe lane, Bath BA2 2EL (GB).

(74) Agents: **CRITTEN, Matthew, Peter,** et al.; Abel & Imray, 20 Red Lion Street, London WC1R 4PQ (GB).

(81) Designated States (national): AE, AG, AL, AM, AT, AU, AZ, BA, BB, BG, BR, BY, BZ, CA, CH, CN, CO, CR, CU, CZ, DE, DK, DM, DZ, EC, EE, ES, FI, GB, GD, GE, GH, GM, HR, HU, ID, IL, IN, IS, JP, KE, KG, KP, KR, KZ, LC, LK, LR, LS, LT, LU, LV, MA, MD, MG, MK, MN, MW, MX, MZ, NO, NZ, OM, PH, PL, PT, RO, RU, SC, SD, SE, SG, SK, SL, TJ, TM, TN, TR, TT, TZ, UA, UG, US, UZ, VC, VN, YU, ZA, ZM, ZW.

[Continued on next page]

(54) Title: BIREFRINGENT OPTICAL FIBRES

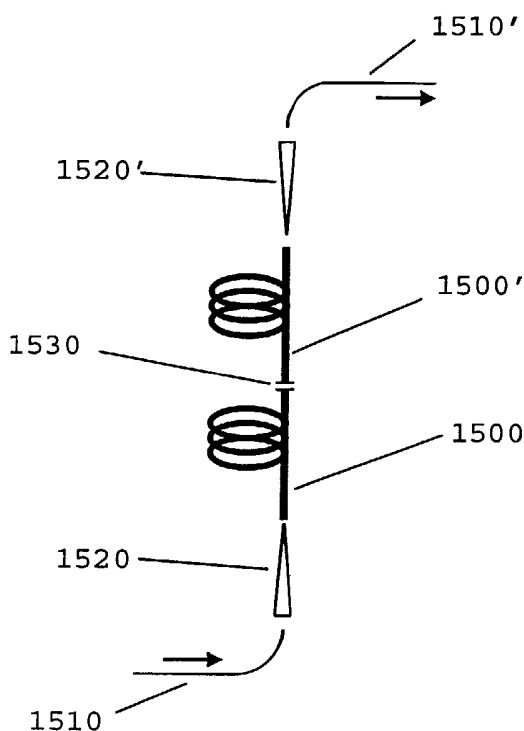

(57) Abstract: A birefringent optical fibre (1500) comprises a first longitudinal region (1500) and a second longitudinal region (1500'). The first region (1500) and second region (1500') each have a fast polarisation axis F and a slow polarisation axis S. The polarisation axes F, S of the first longitudinal region (1500) are rotated with respect to the polarisation axes F, S of the second longitudinal region (1500'). In another aspect of the invention, the fibre (1500), in addition to being birefringent, exhibits a selected amount of dispersion.



WO 03/058308 A2



(84) Designated States (regional): ARIPO patent (GH, GM, KE, LS, MW, MZ, SD, SL, SZ, TZ, UG, ZM, ZW), Eurasian patent (AM, AZ, BY, KG, KZ, MD, RU, TJ, TM), European patent (AT, BE, BG, CH, CY, CZ, DE, DK, EE, ES, FI, FR, GB, GR, HU, IE, IT, LU, MC, NL, PT, SE, SI, SK, TR), OAPI patent (BF, BJ, CF, CG, CI, CM, GA, GN, GQ, GW, ML, MR, NE, SN, TD, TG).

Published:

— *without international search report and to be republished upon receipt of that report*

For two-letter codes and other abbreviations, refer to the "Guidance Notes on Codes and Abbreviations" appearing at the beginning of each regular issue of the PCT Gazette.

Birefringent optical fibres

This invention relates to the field of birefringent
5 optical fibres and in particular to optical-fibre devices
for altering the polarisation of an optical signal and to
dispersion-compensating optical fibres.

Optical fibres are important components of several
technologies, in particular telecommunications technology.
10 Optical fibres are usually made entirely from solid
materials such as glass, and each fibre usually has the same
cross-sectional structure along its length. Transparent
material in one part (usually the middle) of the cross-
section has a higher refractive index than material in the
15 rest of the cross-section and forms an optical core within
which light is guided by total internal reflection. We
refer to such a fibre as a conventional fibre or a standard
fibre.

Most standard fibres are made from fused silica glass,
20 incorporating a controlled concentration of dopant, and have
a circular outer boundary that is typically of diameter 125
microns.

Standard fibres may be single-mode or multimode.
Particular standard fibres may have particular properties,
25 such as having more than one core or being polarisation-
maintaining or dispersion compensating.

Standard fibres are in widespread and routine use and a
wide range of devices based on standard fibres have been
developed.

30 Standard optical fibres operating in the low loss
window around 1550 nm (that is, between about 1510 nm and
1600 nm) exhibit chromatic dispersion, which is generally
undesirable. Chromatic dispersion causes different
frequency components of a light pulse to travel at different
35 speeds in the fibre. In a standard fibre around 1550 nm,

shorter wavelengths travel more quickly than longer wavelengths; that phenomenon is referred to as anomalous dispersion. When longer wavelengths travel more quickly than shorter wavelengths that is known as normal dispersion.

5 Chromatic dispersion causes pulses to distort, for example by spreading in time. Over the long distances involved in many telecommunications applications, that can lead to pulse break up or to successive pulses in a data stream interfering with each other.

10 Dispersion in a long-distance telecomms link is usually compensated by periodically inserting Dispersion Compensation Modules (DCMs) at intervals along the link. DCMs usually comprise a relatively short length of optical fibre (known as Dispersion Compensating Fibre - DCF) that
15 exhibits dispersion of the opposite sign to the principal fibre in the link (i.e. for a standard fibre link in the 1550 nm window, the DCM exhibits normal dispersion). The DCM is arranged to provide just enough dispersion to cancel the dispersion of the principal fibre in the link, so that
20 the net dispersion experienced by a pulse that propagates along the link is approximately zero.

Of course, dispersion compensation may be desirable at other wavelengths and in other applications, for example in pulsed laser devices, and the invention described herein may
25 be applicable in such other circumstances.

DCF is typically approximately cylindrically symmetric fibre that has a so-called 'W-profile' in its refractive index; that is to say that it comprises a high-index core surrounded by an inner cladding region having a lower
30 refractive index, which in turn is surrounded by an outer cladding region having an intermediate refractive index.

A typical single-mode standard fibre is able to support two transverse modes, differing in the polarisation direction of the light they contain. The two modes
35 correspond to light having two orthogonal polarisations.

A major problem in prior-art DCF is polarisation mode Dispersion (PMD). PMD is caused by wavelength-dependent coupling between polarisation states along the fibre length, which is caused by minor deviations from perfect cylindrical symmetry in the compensating fibre, including variations in the properties of the DCF caused by random fluctuations in temperature and stress. The effect worsens the longer the fibre becomes. The perturbations result in signals propagating in two polarisation channels in the fibre, each with a different time delay. The group velocity delay between the two eigen-states of the fibre varies over time. Thus a signal launched into the DCF will be broadened during propagation. Moreover, the delay between the two polarisation states changes strongly with wavelength. The effect becomes more and more serious as the pulse lengths get shorter, i.e., the system capacity becomes larger. PMD is thus highly undesirable.

Systems designers are very keen to obtain DCFs in which the PMD is completely deterministic (i.e., it does not fluctuate with time).

The usual prior-art method of reducing PMD in DCF is to spin the fibre during drawing. Spinning homogenises the fibre to provide cylindrical symmetry and thus reduces PMD to acceptable levels (of the order of ps over the bandwidth).

Recently a new type of optical fibre has been developed known as a photonic crystal fibre (PCF), also known as a microstructured fibre or a holey fibre.

PCFs are fibres having a cladding region that comprises a plurality of elongate regions, running parallel to the longitudinal axis of the fibre, that are of a different refractive index from a matrix region in which they are embedded. The elongate regions are, in many cases, air-filled holes, although they are in some cases solid regions or regions filled with a liquid or another gas.

The core of a PCF is a region having a different structure from the cladding region; it is often a region having no holes or a region having one or more extra holes.

Light is confined to the core of a PCF by the cladding through the action of one of two mechanisms. The first is closely related to the guidance mechanism of a standard fibre. In this mechanism, the matrix regions and the elongate regions of the cladding have an 'effective' refractive index that is less than the refractive index of the core region, so that total internal reflection occurs and traps light in the core. (The 'effective' refractive index of the cladding region can readily be calculated by a person skilled in the art. One method involves calculating the effective refractive index of an infinite plane tiled with the pattern of elongate holes in the cladding region (see, T.A. Birks et al., Electron. Lett. Vol. 31 No. 22, pp 1941-1942 (1995)). In general, the effective refractive index will be between that of the elongate regions and that of the matrix regions.)

In the second mechanism, the arrangement of elongate regions in the cladding is periodic such that they form a photonic band gap. (This phenomenon is analogous to the formation of electronic band gaps in semiconductors.) Interference between light reflected from the elongate regions is such that there are certain bands of frequencies that cannot escape into the cladding. The core of a PCF that guides by this mechanism forms a 'defect' in the periodic structure of the cladding; light can propagate in this defect region. Light is thus confined to and propagates in the core of the PCF.

The term 'photonic crystal fibre' reflects the historical roots of the structure of the fibres; the fibres were developed with a view to demonstrating the band-gap guidance mechanism. However, we refer to all fibres having such elongate regions as photonic crystal fibres, even if

they do not have band-gaps and guide by the first mechanism, index guiding. In particular, the term is not restricted to fibres having periodic arrangements of elongate regions in their claddings.

5 Polarisation-maintaining fibre in PCF is attractive because it is potentially very low loss (limited only by the Rayleigh scattering loss of pure silica glass, roughly 0.2 dB/km) and is far less sensitive to environmental
10 fluctuations than a standard fibre. Examples of highly birefringent polarisation-maintaining fibres are described in International Patent Application No. PCT/GB00/00600 (in the name of The University of Bath *et al.* and published as WO 00/49436), which is hereby incorporated herein by
reference.

15 An object of the invention is to provide a DCF that avoids or ameliorates undesirable PMD effects. Another object of the invention is to provide a device for and a method of altering the polarisation of light that is propagating in a PCF. A further object of the invention is
20 to provide a device and method for reducing polarisation-mode dispersion in a photonic-crystal fibre.

 According to the invention there is provided an optical fibre, comprising a core region and a cladding region, characterised in that the fibre exhibits a selected amount
25 of dispersion and in that it is also birefringent.

 It is known in the prior art to control PMD in standard fibres by deliberately breaking the fibre's cylindrical symmetry to make it birefringent in a fixed and predictable way (rather than being a random effect). Deliberately
30 introducing strong birefringence renders the two polarisation channels deterministically separate and relatively wavelength independent. However, some form of correction is required to remove the huge differential group delays that would otherwise develop between polarisation
35 channels. (Differential Group Delay - DGD is the term we

use for deterministic PMD that does not vary strongly with wavelength.)

To our knowledge it has never been suggested that features can be introduced into a DCF to make it highly birefringent. Indeed, prior art fibres, as discussed above, teach away from such an arrangement because they are spun to reduce birefringence. Thus prior-art teachings are of highly cylindrically symmetric DCF.

Preferably, the fibre has, in its transverse cross-section, a rotational symmetry of two-fold. Of course, the fibre may include structures that break strict two-fold symmetry but that do not affect propagating light sufficiently strongly for the fibre no longer to be polarisation-maintaining.

The birefringence may be form birefringence (that is, it may result from directly the arrangement of elements of the fibre) or stress birefringence (that is, it may result from internal stresses arising from the structure of the fibre).

For example, stress birefringence may be provided by the fibre regions comprising a different material from the material making up the majority of the fibre; for example, rods of a different glass may be included in a glass cladding region.

Preferably, the cladding region comprises a first cladding region, surrounding and adjacent to the core region and a second cladding region, surrounding and adjacent to the first cladding region, the first cladding region having a refractive index that is lower than the refractive index of the second cladding region.

Preferably, the first and second cladding regions are concentric rings. The rings may be substantially circular or may have some other symmetry; for example, the rings may be hexagonal or rectangular.

Preferably, the fibre comprises a third cladding region having an effective refractive index that is lower than that of the second cladding region. The fibre may comprise still further cladding regions.

5 Structures providing the birefringence may be provided in any suitable part of the fibre cross-section. Preferably, the birefringence results from structures in the first cladding region. The birefringence may result from structures in the second cladding region.

10 The core region may contain elongate regions; i.e., it may be microstructured. The birefringence may result from a variation, having two-fold rotational symmetry, in that microstructure.

Preferably, the cladding region comprises a plurality of elongate structures having a first refractive index embedded in a matrix material having a second, different refractive index.

The second cladding region may include a plurality of the elongate elements. Alternatively, the second cladding region may be of a uniform refractive index. When a region is of a uniform refractive index, its effective refractive index is, of course, equal to that uniform index.

The first refractive index may be lower than the second refractive index. For example, the elongate regions may be elongate holes embedded in a solid material of the second refractive index. (The first and second refractive indices are of course material, as opposed to effective, refractive indices.)

The effective refractive index of the part of the cladding region surrounding and adjacent to the core region may be lower than the effective refractive index of the core region. The fibre may then guide by total internal reflection. Such an arrangement may provide a structure analogous to a 'W-profile' standard fibre for dispersion compensation.

Alternatively, the effective refractive index of the part of the cladding region surrounding and adjacent to the core region may be higher than the effective refractive index of the core region. The fibre will then guide by a photonic band-gap effect. Preferably, the core region is an elongate hole. Preferably, light is substantially confined to the elongate hole of the core region.

The different effective refractive indices of each of the regions may result from any suitable mechanism or combination of mechanisms; for example, if a region comprises elongate elements having a lower refractive index than the matrix material, a region having a higher effective refractive index may be provided by the elongate elements having a smaller cross-sectional area and/or a larger pitch (nearest neighbour spacing) in that region. Different materials or different dopants may be used in the elongate elements or in the matrix material in different regions.

Preferably, the fibre is a photonic crystal fibre.

Several examples of birefringent PCFs that exhibit DGD are described in International Patent Application No. PCT/GB00/00600 (The University of Bath), the contents of which Application are hereby incorporated herein by reference. For example, birefringence may be achieved by providing a variation in the cross-sectional area or the shape of the elongate elements, or in the material of, or the concentration of a dopant in, the elongate elements or the matrix material, or by any combination of those or other mechanisms. Any suitable dopant may be used, for example Germanium, Phosphor, Aluminium or Tin.

If light is linearly polarised in a direction parallel to one of the optic axes of a birefringent fibre then the light will maintain its polarisation. If it is linearly polarised at some other angle, the polarisation will change, as the light propagates down the fibre, from linear to elliptical to linear (not parallel to the starting

polarisation) to elliptical and back to linear again, with a period known as the beat length, L_B , where $L_B = \frac{2\pi}{|\beta_x - \beta_y|}$ and

β_x and β_y are the propagation constants of the orthogonal modes. That variation is a consequence of a phase difference between two orthogonal components of the mode, which results from the difference in their propagation constants. The shorter the beat length, the more resilient is the fibre to polarisation-scrambling effects.

In general, stronger birefringence is preferable over weaker birefringence. The degree to which a dispersion compensating microstructured fibre needs to be birefringent in order to overcome PMD is dictated by fluctuations in birefringence along the fibre. A typical microstructured fibre has structural birefringence fluctuations of about 1%. To prevent polarisation cross-coupling induced by the fluctuations, the fibre typically needs a beat length of the order of about a millimetre. Thus, the beat length is preferably less than 1cm, more preferably less than 5mm, more preferably less than 2mm, still more preferably less than 1mm and still more preferably less than 0.5mm. The beat length required is dictated by both the rms magnitude of birefringence fluctuations and the lengths for which they persist (characterised by a power spectrum). (Of course, a particular fibre may not guide light at a wavelength of 1.5 microns; in that case, the beat length at a guided wavelength may readily be scaled up or down to an equivalent beat length at 1.5 microns).

Advantageously, the fibre includes a structure at or near its mid-point that is arranged to interchange the polarisation axes of the fibre relative to the polarisation direction of light propagating in the fibre, or vice versa. The structure may be a twist of 90° (or an integer multiple of 90°). Such a twist may be provided, for example, by

heating and twisting the fibre during the draw or after
 manufacture, or by cleaving the fibre, rotating the cleaved
 parts and splicing them back together again. Alternatively,
 the structure may be a region in which the cross-sectional
 5 areas of holes in the structure change to rotate the cross-
 sectional pattern of the fibre by ninety degrees about the
 core. Such arrangements would interchange the fast and slow
 polarisation axes of the fibre. Such an arrangement may be
 provided for example by varying pressure in holes in the
 10 fibre during the draw, so that large holes become small and
 vice versa in a change in pattern that provides a 90 degree
 rotation of the axes.

A successful dispersion compensating fibre must have
 high dispersion and the correct dispersion slope. We assume
 15 that the fibre link to be compensated for is L_0 km long and
 that its dispersion (ps/nm) is given by:

$$d_0(\lambda) = L_0 D_0 [1 + RDS_0 (\lambda - \lambda_0)]$$

where D_0 is the 'bulk' dispersion in ps/nm.km at $\lambda = \lambda_0$ and
 20 RDS_0 the relative dispersion slope in nm^{-1} .

An ideal compensating fibre will be L km in length and
 have much higher bulk dispersion D (opposite in sign to D_0)
 and the same magnitude of RDS but opposite in sign. The
 module properties must satisfy the relationship:

25

$$d_0(\lambda) = -LD [1 + RDS(\lambda - \lambda_0)]$$

and an ideal module will have a very large value of D and
 hence small L .

Our solution to this problem is to rotate the axis of
 30 the PM-DC fibre, or the polarisation of propagating light in
 the middle of the fibre, so as to exchange the signals
 travelling in orthogonal polarisation states. This means

that the DGD will unwind itself in travelling to the output end of the twisted DC-PM fibre, yielding zero DGD and PMD.

Taking the dispersion and *RDS* for each polarisation channel to be D_1 and D_2 and RDS_1 and RDS_2 , the equation that
5 must be satisfied for the module to work is:

$$d_0(\lambda) = -(L/2)[D_1(1+RDS_1)(\lambda-\lambda_0) + D_2(1+RDS_2)(\lambda-\lambda_0)]$$

where L is the total DCF length. If the twist is placed in the middle to form a symmetric arrangement, the net DGD will
10 be zero.

The structure may be a plurality of small twists (of, say, less than ten degrees), with each twist rotating in a sense opposite to that of its immediate neighbours, such that the twists form a rocking filter. In such an
15 arrangement, the twists preferably reverse their sense on a length scale of the order of the beat length of the fibre.

Alternatively, the fibre may include a plurality of structures arranged to interchange the polarisation axes of the fibre relative to the polarisation direction of light
20 propagating in the fibre, or vice versa. Thus, rather than having one such structure at the centre of the fibre (dividing the fibre into two), $2N-1$ such structures ($N>1$) may be provided, dividing the fibre into $2N$ lengths. As each length will be shorter than in the $N=1$ case, there is
25 less risk that local differences between lengths will cause imperfect cancellation of DGD; i.e. a higher accuracy of cancellation will be possible.

Preferably, the fibre exhibits normal dispersion at 1.55 microns. Alternatively, the fibre exhibits anomalous
30 dispersion at 1.55 microns.

Also according to the invention there is provided a method of controlling chromatic dispersion and polarisation-dependent dispersion of a light pulse, comprising

propagating the pulse through a fibre as described above as being according to the invention.

Preferably, the method includes the step of heating and/or straining a portion of the fibre. Heat and/or strain
5 may be used to fine-tune the DGD properties of one half of the fibre in order to improve DGD cancellation over the fibre length. Preferably, the method includes the step of altering the temperature and/or strain according to feedback from a monitor monitoring the pulse. Preferably, the
10 elongate structures are circular in transverse cross-section. Alternatively, the elongate structures may be arcuate in transverse cross-section. Preferably, at least one of the arcuate structures subtends an angle of 30 degrees or more, or more preferably 60 degrees or more,
15 about the centre of the core region.

Also according to the invention there is provided a dispersion compensator comprising a fibre as described above as being according to the invention.

Also according to the invention there is provided an
20 optical device comprising a fibre as described above as being according to the invention. Preferably, the device further comprises a quarter-wave plate and mirror arranged to rotate by 90° , or an integer multiple of 90° , the polarisation of light exiting the fibre and to return the
25 light to the fibre.

Also according to the invention there is provided an optical device comprising a beam-splitter, for splitting light into two orthogonal polarisation components, and a polarisation-maintaining optical fibre; the device being
30 arranged such that the two polarisation components propagate along the same path in the fibre but in opposite directions and such that the polarisation components both propagate in the fibre polarised in the same orientation relative to the principal state of polarisation (PSP) axes of the fibre.

Preferably, the polarisation components both propagate in the fibre polarised in the same orientation relative to the principal state of polarisation (PSP) axes of the fibre because the fibre is twisted by 90° , or an integer multiple of 90° .

Alternatively, the polarisation components both propagate in the fibre polarised in the same orientation relative to the principal state of polarisation (PSP) axes of the fibre because a wave-plate is arranged to rotate the polarisation of the polarisation components. Any other suitable arrangement may be used.

Preferably, the device further comprises a circulator for coupling light from a single-mode fibre into the beam-splitter.

Alternatively, the device comprises a plurality of polarisation-rotators, arranged to rotate each polarisation component such that a component that is reflected by the splitter into the fibre is, after propagation through the fibre, output from the splitter by reflection and a component that is transmitted by the splitter into the fibre is, after propagation through the fibre, output from the splitter by transmission.

Also according to the invention there is provided a method of compensating chromatic dispersion in an optical system, comprising propagating light from the optical system through a fibre or a device as described above as being according to the invention.

Also according to the invention there is provided an optical system comprising a first, chromatically dispersive, optical fibre and a second, optical fibre, that is according to the invention, the first fibre being longer than the second fibre and the second fibre exhibiting a chromatic dispersion that compensates for the chromatic dispersion of the first optical fibre.

In some of its aspects, the invention may be applicable to any birefringent fibre types, regardless of dispersion properties.

Also according to the invention there is provided an optical fibre comprising a first longitudinal region and a second longitudinal region, the first and second regions each having a fast polarisation axis and a slow polarisation axis, characterised in that the polarisation axes of the first longitudinal region are rotated with respect to the polarisation axes of the second longitudinal region.

Preferably, the fibre is a photonic crystal fibre.

Preferably, the polarisation axes are rotated because the fibre includes a twist.

Highly birefringent standard fibres generally contain high internal stresses and twisting such a fibre would often destroy the fibre, although the invention may be applied to such a fibre. Imperfections in the arrangement of longitudinal regions in a PCF typically results in even a PCF that has not been designed to be highly birefringent being sufficiently birefringent to be polarisation-maintaining. The internal stresses in a birefringent PCF are generally much lower than those of a birefringent standard fibre and a PCF may thus be twisted without it being destroyed.

Preferably, the fast polarisation axis of the first region is aligned with the slow polarisation axis of the second region. Preferably, the slow polarisation axis of the first region is aligned with the fast polarisation axis of the second region. Thus, light propagating in the fibre, which maintains its polarisation direction relative to the fibre's environment, effectively has its polarisation direction swapped relative to the polarisation axes of the fibre.

Preferably, the twist occurs over a length of the fibre that is less than the beat length of the fibre.

Preferably, the twist occurs over a length of the fibre that is sufficiently short that light polarised along the fast polarisation axis of the first region is transferred without leakage loss to the slow polarisation axis of the second region. Preferably, the twist occurs over a length of the fibre that is sufficiently short that light polarised along the slow polarisation axis of the first region is transferred without leakage loss to the fast polarisation axis of the second region. Suitable lengths in any given embodiment may readily be determined by the skilled person. A smooth transition results in essentially lossless polarisation switching.

Preferably, the twist is at the centre of the length of the fibre. When the twist is provided halfway along the fibre, the fibre may have a deterministically very small group delay; at the twist, light swaps over between polarisation states in a wavelength-insensitive manner and at the output of the fibre the two pulse components, of orthogonal polarisation, arrive at exactly the same moment, eliminating group delay to within the accuracy of the fibre length. Furthermore, in a polarisation-maintaining PCF, the group delay will typically not vary significantly with temperature since polarisation-maintaining PCF is not vulnerable to stress-induced changes in birefringence. An additional advantage is that PCF is intrinsically insensitive to environmental effects.

Preferably, the photonic crystal fibre comprises a plurality of twists, such that there is at least one further longitudinal region having its axes rotated with respect to the axes of an adjacent longitudinal region such that the fast polarisation axis of the further region is aligned with the slow polarisation axis of the adjacent region.

As an alternative to the sharp twist required to swap the polarisation axes of the fibre, the axes of the first region may be rotated with respect to the axes of the second

region by only a small amount. Preferably, the fibre contains a plurality of twists, such that there is at least one further longitudinal region having its axes rotated by only a small amount with respect to the axes of an adjacent longitudinal region. Preferably, the axes of adjacent longitudinal regions defined by the twists are rotated in opposite directions. Preferably, the axes of adjacent longitudinal regions defined by the twists are rotated by angles of equal magnitude. More preferably the longitudinal regions have a length that is equal to one half of their beat length.

In this alternative embodiment, the plurality of twists may thus form a 'rocking' filter, in which light is gradually transferred from one polarisation to the other by the twisting of the axes of adjacent regions in opposite directions.

Provision of a small number (perhaps five to ten) of such longitudinal regions that are each rotated by a relatively large angle (perhaps five to ten degrees) may be used to provide a filter with a wide bandwidth.

Preferably, the twists each occur over a length of the fibre that is sufficiently short that light is transferred without leakage loss between adjacent longitudinal regions.

The polarisation axes of the fibre according to the invention may be rotated because the fibre comprises two spliced fibres that are rotated relative to each other.

Preferably, the rotation is such that the fast polarisation axis of the first region is aligned with the slow polarisation axis of the second region.

Preferably, the splice is at the centre of the fibre.

Preferably, the splice is a fusion splice. Preferably a transition region is provided adjacent to the splice, in which the strength of birefringence falls from its usual value in the first and second fibres to zero at the splice.

Such a transition region may improve the loss properties of the splice.

Preferably, the fibre is connected at each end to a single-mode fibre. Preferably, the connection is via a
5 taper.

As discussed above, polarisation-mode dispersion is a particular problem in dispersion-compensation modules employing a standard fibre. The fibre according to the invention may exhibit anomalous chromatic dispersion or
10 normal chromatic dispersion. Also according to the invention there is provided a dispersion compensation module comprising such a fibre.

Many other optical devices incorporating a photonic crystal fibre as described above as being in accordance with
15 the invention are envisaged. For example, also according to the invention, there is provided an optical coupler or splitter or an interleaver comprising a fibre described above as according to the invention. A measuring device may also be provided incorporating a fibre according to the
20 invention.

Also according to the invention there is a method of manufacturing an optical fibre for altering the polarisation of propagating light, comprising rotating a part of an optical fibre to create a first longitudinal region and a
25 second longitudinal region, the first and second regions each having a fast polarisation axis and a slow polarisation axis, the rotation being such that the polarisation axes of the first longitudinal region are rotated with respect to the polarisation axes of the second longitudinal region.

30 Preferably, the rotation is a rotation of 90° .

Preferably, the fibre is a photonic crystal fibre.

Preferably, the rotation is achieved by heating a portion of the fibre and twisting the fibre in the heated portion.

Such a twist may not readily be provided in a standard fibre because induced stresses are likely to destroy the fibre.

Preferably, the heating and twisting occurs during
5 drawing of the fibre from a preform. Alternatively, the heating and twisting takes place after the fibre has been drawn from a preform.

The heating may be carried out using any suitable means, such as a CO₂ laser or a flame.

10 Alternatively, the rotation may be achieved by providing a first optical fibre and a second optical fibre, the first and second fibres each having a fast polarisation axis and a slow polarisation axis, and splicing the first fibre and the second fibre together such that the
15 polarisation axes of the first fibre are rotated with respect to the polarisation axes of the second fibre.

Preferably, the splice is a fusion splice.

Preferably, a transition region is provided adjacent to the splice, in which the strength of birefringence falls
20 from its usual value in the first and second fibres to zero at the splice. Such a transition region may improve the loss properties of the splice. The transition region may be provided by heat treatment either before or after the splicing. Heat treatment may be used to make the fibre
25 adjacent to the splice optically circularly symmetric. In the case of a PCF, that may be achieved for example by causing the collapse of hole structures providing the birefringence and in a standard fibre it may cause dopant diffusion to circularise the core and/or to eliminate stress
30 birefringence.

Preferably, the first and second optical fibres are photonic crystal fibres. Although this splicing technique may be applied to a standard fibre, it would preferably be applied to a photonic crystal fibre, because polarisation-

maintaining standard fibres are expensive and generally do not provide simultaneous dispersion compensation.

Preferably, the first fibre and the second fibre are provided by cleaving a fibre into two portions.

5 The photonic crystal fibre may be drawn from a preform comprising a bundle of rods, the rods being arranged to form a core region and a cladding region surrounding the core region, the cladding region comprising a plurality of elongate regions embedded in a matrix region. The elongate
10 regions may be, for example, holes formed from rods that are capillaries.

Also according to the invention there is provided an optical fibre comprising a first longitudinal region and a second longitudinal region, the first and second regions
15 each having a fast polarisation axis and a slow polarisation axis, characterised in that the fibre comprises two spliced fibres that are rotated relative to each other at the splice, such that the polarisation axes of the first longitudinal region are rotated with respect to the
20 polarisation axes of the second longitudinal region.

Preferably, the optical fibre is a photonic crystal fibre.

Also according to the invention there is provided a method of propagating a light signal, comprising propagating
25 the light along a fibre described above as being according to the invention, wherein the polarisation of the light is rotated at the, or at the first, rotation of the polarisation axes of the fibre (for example, at the, or at the first, twist or splice).

30 Preferably, the polarisation of the light is in a first principal state of polarisation before reaching the, or the first, rotation of the polarisation axes of the fibre and it is in a second principal state of polarisation when it leaves the rotation or the last such rotation.

Also according to the invention there is provided a method of compensating for polarisation mode dispersion, comprising propagating a light signal along a first region of a fibre and then propagating the light signal along a second region of the fibre of equal length to the first region, characterised in that the polarisation of components of the light signal is rotated between the first and second regions, relative to the fast and slow polarisation axes of the fibre.

10 Preferably, the rotation results because the fast and slow polarisation axes of the first region are aligned with the slow and fast polarisation axes, respectively, of the second region.

Alternatively, the rotation results from the effect of a rocking filter provided between the first and second regions.

According to the invention there is provided a device comprising first and second fibre portions, both having at least a fast and a slow polarisation axis, there being provided a region optically coupling the first and second fibre portions for coupling light from the first fibre portion travelling in the fast and slow polarisation axes to the slow and fast polarisation axes respectively of the second fibre portion such that polarisation dependent effects of the first fibre portion are substantially compensated for by polarisation dependent effects of the second fibre portion.

The polarisation dependent effects may be, for example, PMD or other birefringence-related polarisation effects.

30 Embodiments of the invention will now be described, by way of example only, with reference to the drawings, of which:

Fig. 1 is a transverse cross-sectional view of a first preform for making a fibre according to the invention;

Fig. 2 is a transverse cross-sectional view of a first fibre according to the invention;

Fig. 3 is a transverse cross-sectional view of a second fibre according to the invention;

5 Fig. 4 is a transverse cross-sectional view of a third fibre according to the invention;

Fig. 5 is a transverse cross-sectional view of a second preform for making a fibre according to the invention;

10 Fig. 6 is a transverse cross-sectional view of a third preform for making a fibre according to the invention;

Fig. 7 is a transverse cross-sectional view of a fourth fibre according to the invention;

Fig. 8 is a schematic showing a fifth fibre according to the invention;

15 Fig. 9 is a longitudinal cross-sectional view of two forms of a detail of the fibre of Fig. 8;

Fig. 10 is a schematic showing the polarisation properties of a sixth fibre according to the invention.

20 Fig. 11 is a seventh fibre structure according to the invention, which has been numerically modelled to produce Figs. 12 to 14.

Fig. 12 is a plot of the variation of dispersion with wavelength for the two polarisation modes of the fibre of Fig. 11.

25 Fig. 13 is a plot of the variation of DGD with wavelength for the fibre of Fig. 11.

Fig. 14 is a plot of the variation of beat length with wavelength for the fibre of Fig. 11.

30 Figs. 15 to 18 show device configurations incorporating a polarisation-maintaining (birefringent) microstructured fibre.

Fig. 19 is an example of a birefringent, polarisation-maintaining photonic crystal fibre.

35 An example of birefringent polarisation-maintaining photonic crystal fibre 1 includes, in a transverse cross-

section (Fig. 19), a cladding region 3 formed from a plurality of elongate holes 4 arranged in a triangular lattice pattern in a silica matrix material. At the centre of the holes 4, an air hole is missing from the lattice, there being instead a region of silica that forms a core region 2. The cladding region 3 confines light to the core region 2 because the air holes 4 result in the cladding region 3 having a lower effective refractive index than the solid silica core region 2 so that total internal reflection can occur between the core region 2 and the cladding region 3. The fibre 1 also includes a jacket region 5, which is provided to provide the fibre with mechanical strength and protection.

On opposite sides of, and adjacent to, core region 2 there are two groups of holes 9 that are larger than the other holes 4. These larger holes act to make the fibre 1 birefringent, with a first (fast) principal axis F running through holes 9 and a second (slow) principal axis S running at right angles to the first axis.

A way of manufacturing fibres according to one aspect of the invention is to use a preform^{*} such as that shown in Fig. 1. The preform comprises a bundle 10 of silica rods 40 and silica tubes 30. The rods 40 and tubes 30 each have an external diameter of about 1mm and they are arranged on a triangular lattice to form concentric hexagonal rings; thus rings of rods and rings of tubes alternate as one moves outward from the centre of the fibre. The bundle is held together in a large silica jacketing tube 50. At the centre of the fibre is a core region 20, formed by omitting seven rods/tubes from the centre of the bundle. The rods 40 and tubes 20 are fused together to form the preform 10; they are held in place around core region 20 during the fusion by using seven short rods (not shown) at each end of the bundle 10, arranged at the sites corresponding to the missing rods/tubes of Fig. 1.

Preform 10 is drawn into a fibre, having a diameter of about 70 microns, by heating and drawing on a standard fibre drawing rig in substantially the same manner as standard fibres are drawn from a preform.

5 In each of the embodiments discussed below, holes of different cross-sectional area are provided in a single fibre. The different cross-sectional areas can be provided in any suitable way using preform 10. For example, one approach is to provide larger and smaller holes by using
10 tubes 30 all having the same external diameter but larger and smaller internal diameters, respectively.

Another approach is to provide tubes 30 and/or rods 40 having different external and internal diameters. Interstitial holes, caused in such an arrangement by
15 imperfect tiling of the rods 40 and tubes 30 in the cross-section of the fibre, are eliminated by connecting the preform 10 to a pressure pump during drawing and evacuating air from the between the rods 40 and tubes 30, whilst maintaining a higher pressure within tubes 30, for example
20 by sealing the ends of the tubes 30 so that they are not evacuated.

Another approach is to increase or decrease the pressure inside particular ones of tubes 30, according to whether an increase or a decrease, respectively, in hole
25 size is required to produce a particular pattern. So, for example, during drawing, holes that are required to be enlarged significantly are connected to a source of positive pressure, holes that are required to be reduced are left open to the atmosphere and holes that are required to take
30 an intermediate size are sealed at their ends (of course, all of the holes are, in fact, very much reduced in cross-sectional area when the fibre is drawn, usually by a factor of several thousands. References to enlarging holes and reducing holes and the like of course refer to relative
35 changes on hole size, compared with the uniform hole size of

tubes 30 in preform 10. Holes in the drawn fibre fill the cladding region to a filling fraction (air:silica) of about 40% and have a pitch (nearest-neighbour spacing) of about 5 microns and a diameter of the order of a few microns

5 (typically between about 1 micron and about 15 microns, although the exact value of course varies between larger and smaller holes and in different embodiments).

Fibre 100 (Fig. 2) comprises hollow core 120 (resulting from hole 20 in preform 10), five concentric, hexagonal
10 rings of holes 130, 160, 170 embedded in a silica matrix 140 (resulting from rods 40 and tubes 30) and a jacketing region 150 (resulting from jacketing tube 50).

Holes 160, forming a first cladding region in the form of the innermost ring, adjacent to core 120, are relatively
15 large. Holes 170, forming a second cladding region in the form of the next innermost ring, are relatively small. Holes 130, forming further cladding regions in the form of further rings, are of intermediate size. In terms of effective refractive index, it will readily be understood
20 that the fibre 100 thus comprises an innermost cladding region of lower refractive index (it is mostly air), a second cladding region of higher refractive index (it is mostly silica) and further cladding regions of intermediate effective refractive index.

25 Light of particular frequencies is confined to the hollow core 120 of the fibre by band-gap effects resulting from the refractive-index structure of the fibre. This can be understood in terms of light interfering destructively from the boundaries between each ring of different
30 refractive index and thus light being prevented from propagating in the cladding, so that, once it is introduced into the fibre, it is confined to core region 120. The physics behind such structures is well-known in the art (see, for example Cregan et al., Science Vol. 285, pp1537-
35 1539 (1999)).

Provision of larger holes 160 and smaller holes 170 results in the fibre displaying normal dispersion at wavelengths around 1550 nm.

The second ring of holes 170 out from the centre
5 comprises holes 170 of a diameter chosen to provide compensation for the dispersion slope of the light that is to propagate in the fibre; thus both dispersion and dispersion slope are compensated, the former by the first ring of holes and the latter by the second ring.

10 Introduction of two-fold symmetry does not strongly affect the dispersion of the dispersion slope.

The fibre 100 also comprises regions 180 that are made of silica doped with 10 mol% Germanium, such that the bulk refractive index of regions 180 is raised relative to the
15 rest of the fibre 100 (which is made of undoped silica). Regions 180 are provided by providing Germanium-doped silica rods 40 and tubes 30 at sites in preform 10 corresponding to regions 180 (and undoped silica rods 40 and tubes 30 elsewhere).

20 Regions 180 are provided on opposite sides of core region 120 and result in fibre 100 having a refractive index profile that has two-fold rotational symmetry. Fibre 100 is thus birefringent.

In the discussion below of further embodiments of the
25 invention, the same numbers will be used for the same features of the fibres of the embodiments, to avoid unnecessary repetition of description.

Fibre 200 is another example of a fibre according to the invention (Fig. 3). Fibre 200 is made of pure silica,
30 with no dopants. Birefringence is instead achieved by providing six enlarged holes 260 and six slightly reduced holes 280, in the first cladding region (in place of uniformly large holes 160 in fibre 100). Holes 260 are arranged in groups of three on opposite sides of core region
35 220, as are holes 280; a pattern having two-fold rotational

symmetry is thus formed, providing the birefringence, which in this case is form birefringence.

By way of demonstrating that the particular form of guidance that a fibre exhibits is not a significant aspect of the invention in its broadest aspect, in this example, 5 core region 220 of fibre 200 is of solid silica (in contrast to the elongate hole forming core 120 in fibre 100). Fibre 200 thus guides light by total internal reflection at the step in effective refractive index between the solid silica 10 core and the innermost ring of holes 260, 280.

Fibre 300 (Fig. 4) is similar to fibre 100 but, instead of doped regions 180, birefringence is stress birefringence provided by the presence of two elongate regions 380, of a different glass from the rest of the cladding glass, and 15 arranged on opposite sides of the core region 120. Regions 280 are too far away from core 120 to have a significant direct effect on propagating light (in particular, they do not significantly affect the band-gap guidance properties of the fibre but their large size results in stress in the 20 silica of the fibre, resulting in anisotropy in refractive index). Specifically, a refractive index structure having two-fold rotational symmetry is created by the stresses.

Preform 400 (Fig. 5) is a second preform suitable for drawing fibres according to the invention. Preform 400 is 25 similar to preform 10, in that it is a bundle enclosed in a jacketing tube 50, but tubes 30 are in this case packed in a square lattice pattern (rather than a triangular lattice pattern). No rods are required to form the holey cladding region; matrix regions result from the silica outer parts of 30 the tubes 30 forming the cladding holes. Rod 420 forms a core region and rods 40 are provided to pack the gap in the preform between the tubes 30 and the jacketing tube 50.

In an alternative embodiment (not shown) an asymmetric core region is provided in a fibre by substituting two rods 35 420 (rather than one) for tubes 30 in preform 400.

Preform 600 (Fig. 6) is a third preform suitable for drawing fibres according to the invention. Preform 600 comprises a plurality of concentric tubes 640 that are spaced apart from each other by tubes 630. A hollow core region 620 is provided by the innermost one of tubes 640. Two rods 680 are provided in place of two of tubes 630, on opposite sides of core 620, to break the symmetry of the structure.

Fibre 700 (Fig. 7) is drawn from preform 600 or another suitable preform. Fibre 700 comprises concentric solid silica tubular regions 740 (resulting from tubes 640), separated by bridging regions 745, which result from tubes 630. Tubes 630 are collapsed by evacuation during the draw, to form bridging regions 745, whereas pressure is maintained in the spaces between tubes 630, so that arcuate holes 730 result in the drawn fibre 700. Bridging regions 780 are larger than regions 745 and result from rods 680. Bridging regions 780 are at sites that provide two-fold circular symmetry in fibre 700.

The invention enables production of a fibre exhibiting negligible PMD and, in a preferred embodiment, a dispersion compensation fibre exhibiting negligible PMD and negligible DGD (Fig. 8). Fibre 800 has a structure that results in birefringence (for example, the structure of any of fibres 1, 200, 300 or 400, described above). However, fibre 800 includes region 810, exactly half-way along the fibre's length (at B in Fig. 8 (a)), in which the polarisation axes of fibre 800 are interchanged (compare Figs 8(b) and 8(c), showing the positions of representative large hole 820 and small hole 825 at positions A and C in the length of fibre 800). Region 810 thus divides the fibre 800 into two identical regions 801 and 802. With reference to the example of fibre 1, axes F and S have effectively been interchanged in region 802 compared with their directions in region 801 because of the change at region 810, which

results in a rotation of holes 9 by ninety degrees about the core region 2.

The effect is illustrated schematically in Fig. 8, in which one of the two polarisation axes of the fibre is shown as a bow-tie shape. The bow-tie shape at each of A, B and C indicates, by the direction of the bow tie's longitudinal axis, the direction of slow polarisation axis S of the fibre. The double headed arrows represents the polarisation direction of linearly polarised light propagating in the fibre. Thus, in region 801, propagating light is linearly polarised along polarisation axis S. In the region 810, the polarisation axes are interchanged, as discussed above. The polarisation of the propagating light does not change in its passage from region 801 into region 802. However, as described above, the polarisation axes of fibre 800 have swapped. In region 802, the propagating light is therefore linearly polarised along polarisation fast axis F. At A, the light is polarised along the polarisation axis orthogonal to the axis shown by the bow-tie. At B, the axes of the fibre are rotated such that at C the axis shown by the bow-tie is now parallel to the polarisation of the light.

Fibre 800 exhibits a predictable birefringence in the form of DGD, rather than an unpredictable amount of PMD. The swap in axes at 810 results in propagating light experiencing equal and opposite amounts of DGD in the first and second halves 801, 802 of fibre 800, respectively. Thus the DGD experienced by light in each half of the fibre cancels out.

In use, the temperature of (and/or stress in) one half of the fibre is used to fine-tune the DGD of that half and thus keep the cancellation over the whole fibre perfect, via a feedback arrangement monitoring polarisation properties of light propagating through the fibre. Our experiments provide evidence that temperature changes the DGD of the

fibre without altering the dispersion or dispersion slope significantly.

Two possible mechanisms for swapping the polarisation axes of the fibre are shown schematically in Fig. 9 (a) and (b). In the first (Fig. 9 (a), corresponding to Fig. 8(b) and (c)), the fibre is twisted at region 810' by ninety degrees, so that the positions relative to core 110 of large holes such as hole 820 and small holes such as hole 825 are altered (i.e. rotated by ninety degrees about core 110). Thus, fibre 800 is divided into the two longitudinal regions 801 and 802 that are of equal length and are separated by a twisted region at 810'. The twist is provided by placing fibre 800 on a fibre tapering rig, of a type well known in the art for tapering standard fibres. Region 810' is heated until the silica softens and then length 802 is rotated by ninety degrees in a rotatable chuck. The beat length of this (highly birefringent) fibre is about 500 microns at 1.55 nm. The length of region 810 is about 100 microns, which is sufficiently short for light propagating in the fibre 800 to pass adiabatically (that is, without loss) from region 801 to region 802.

In the second mechanism (Fig. 9(b)) there is no rotation about the core 110; rather, the change in position of the large and small holes is achieved by changing the size of holes such as holes 920 and 925 so that, for example, hole 920 changes from small to large at region 810'' and hole 925 changes from large to small (moving from left to right in Fig. 9 (b)). Such a change in hole size may be achieved for example by changing pressure in the holes 920, 925 during drawing. (The hole pattern shown in Fig. 8 (b) and (c) is not consistent with this mechanism; to make it consistent, the reference numerals 820 and 825 should be swapped in respect of Fig. 8(b)).

A further mechanism for swapping the polarisation axes of the fibre is shown schematically in Fig. 20. This

described embodiment of the invention utilises a birefringent standard fibre but of course it could alternatively utilise a birefringent PCF. In this embodiment, the twist in the first embodiment is replaced by
5 a simple splice 850 of two component fibres 860, 870, wherein the polarisation axes of the two fibres 860, 870 are rotated by 90 degrees with respect to each other where the splice 850 is made. Transition regions 880, 890 are provided around the splice 850, in which the strength of
10 birefringence in each component fibre 860, 870 is reduced from its usual value to zero at a non-birefringent midpoint at the splice 850, as shown schematically in Fig. 20 (b) and (c). Because the reduction and subsequent increase of the birefringence is gradual, the transition is adiabatic. The
15 transition regions 880, 890 are formed by heat-treating the component fibre 860, 870 to produce circular symmetry at the point at which the component fibre 860, 870 is to be cleaved.

The strength of birefringence is represented in two
20 ways in Fig. 20: by the size of the "bow-tie" in Fig. 20 (c) and by the ellipticity of a schematic fibre core in Fig. 20 (b). A PCF core will not in general be elliptical but the representation is useful to illustrate the strength of anisotropy.

25 As an alternative to swapping the polarisation axes of the fibre, the polarisation axes of propagating light may be swapped (Fig 10). A 'rocking filter' 1020, comprising a number of small rotations 1010, is provided at the centre of the length of fibre 1000.

30 Fibre 1000 comprises, like fibre 1 in Fig. 19, in its transverse cross-section, a cladding region comprising a plurality of holes that are arranged on a triangular lattice pattern. In this embodiment, the holes form a photonic band-gap that prevents propagation of light at around 1550
35 nm in the cladding. The lattice pattern is broken by a

defect in the form of an enlarged hole, which forms a core region. Light at 1550 nm can propagate in the core region and it is confined to the core region by the band-gap of the cladding region. A jacket region is provided for mechanical strength and protection.

Imperfections in the arrangement of holes cause fibre 1000 to be birefringent. Fibre 1000 is also dispersive because light of longer wavelengths will spread further out from the core of the fibre and into the cladding than light of shorter wavelengths. (of course, in alternative embodiments of the invention, other features of the fibre that cause it to have at most two-fold symmetry, such as a particular (e.g. elliptical) core shape, may also cause or contribute to the birefringence of the fibre.)

Thus, along its length, fibre 1000 is divided into longitudinal region 1030, which has polarisation axes that are in a fixed direction, rocking filter region 1020 and longitudinal region 1040, which has polarisation axes that are fixed in the same direction as those of region 1030. The rocking filter 1020 comprises short longitudinal regions T-Y, each about 1 mm in length, which have polarisation axes that are rotated by five degrees either side of the polarisation axes of regions 1030 and 1040, with alternate sections being rotated clockwise looking from region 1030 to region 1040 and anti-clockwise.

Optimal coupling is given when

$$\kappa L = \frac{\pi}{2}$$

where L is the coupling length and κ is the coupling constant

$$\kappa = \frac{2\pi\theta}{L_B}$$

where θ is the angle of rotation and L_B is the beat length

$$L_B = \frac{\lambda}{|n_s - n_f|}$$

where λ is the wavelength of the propagating light (in this case 1550 nm) and $n_s - n_f$ is the difference between the refractive indices of the slow axis and the fast axis in the region. Hence the relationship between the length of longitudinal region and the angle of rotation required is given by:

$$\theta_L = \frac{L_B}{4}.$$

Rocking filter 1020 is made in a similar manner to twist 810'. The fibre is placed in a drawing rig, region 1030 is clamped in place and then region 1040 is rotated relative to region 1030 to form twist T. Unlike in the case of twist 810', however, the rotation is by only 5 degrees. The fibre 1000 is cooled and then re-clamped at T. Twist U is formed by heating that region of the fibre and rotating it by ten degrees in the opposite sense to the twist that formed twist T (i.e., clockwise instead of anticlockwise or vice versa). The fibre 1000 is again cooled and then region V is formed by heating that region of the fibre and rotating it by ten degrees in the direction of the rotation that formed twist T. The cooling, heating and twisting is repeated to form all of regions T-Y. The twists T-Y together form, along the length of the fibre 1000, a sinusoidal variation of the direction of the polarisation axes of the fibre.

The behaviour of light propagating in fibre 1000 may be understood with the aid of the bow-tie symbols of Fig. 10.

In region 1030, propagating light is linearly polarised along the fast polarisation axis F. When the light passes into twist T, the small rotation of the polarisation axes means that the light is split into two components, polarised along the new axes. The majority of the light is polarised along the rotated F axis but a small fraction ($\sin \delta\theta$, where

$\delta\theta = 5$ degrees in this example) is polarised along the rotated S axis. The length of each of the regions T to Y is equal to half of the beat length L_B for that region. A full period of the sinusoidal variation provided by the twisting (i.e., two of regions T to Y) is thus equal to the beat length. Consequently, the light passes into twist U when the light transferred onto the slow axis is at a maximum. A similar effect occurs in region U and is repeated in each of regions V to Y. As each region has a length of half its beat length, the effects of the transfers reinforce each other and when light reaches region 1040, its polarisation has been entirely transferred to the slow polarisation axis.

A rocking filter 1020 acts as a passband polarisation filter, transferring light around wavelength λ from one polarisation to an orthogonal polarisation. The filter 1020 is arranged so that all wavelengths of interest are completely transferred between polarisation states.

A rocking filter 1020 may be used in a dispersion compensation module instead of a ninety-degree splice or twist. The rocking filter 1020 has the same effect as a ninety-degree splice or twist in that it rotates the polarisation of light by ninety degrees relative to the polarisation axes of the fibre. The rocking filter 1020 does that by rotating the polarisation of the light, whereas the splice or twist does it by rotating the polarisation axes.

(A photonic crystal that guides by a photonic band-gap is used in the embodiment of Fig. 10 by way of illustration of an alternative to the total-internal reflection photonic crystal fibre of Fig. 1. Of course, either guidance mechanism may be employed)

Thus, at S, before light enters the filter, light is polarised orthogonally to one of the polarisation axes (represented by the bow-tie in Fig. 10) of the fibre 1000. At each of regions T to Y the polarisation axes of the fibre

are rotated by a few degrees (~ 5 degree). As discussed, the separation of the rotations 1010 is equal to half the polarisation beat length of the fibre; light is therefore coupled from its original polarisation to the orthogonal polarisation at each rotation 1010 and the coupling is reinforced at each rotation 1010 such that power is gradually transferred entirely to the polarisation parallel to the fibre polarisation axis represented by the bow-tie in Fig. 10. As the length of the rocking filter is very much less than the length of the fibre, DGD experienced in the first half of fibre 1000 will again be cancelled by an equal and opposite amount of DGD in the second half of fibre 1000.

In general, one can say that the bandwidth of 100% conversion is inversely proportional to the number of periods. Fewer periods means a larger rocking angle is required.

The sharply twisted fibre of Fig. 8 switches the polarisations of all wavelengths propagating in the fibre, whereas the rocking filter is wavelength sensitive and only switches wavelengths in a passband. A wavelength-dependent polarisation coupler may therefore readily be provided using the rocking filter embodiment.

In a preferred embodiment, fibre 800 is, because of its refractive-index profile, a dispersion-compensating fibre, exhibiting significant chromatic dispersion as well as DGD (for example, having the structure of any of fibres 200, 300 or 400 described above).

The chromatic dispersion and polarisation dispersion properties of a further example of a fibre structure according to the invention (Fig. 11) were modelled using a computer.

The fibre comprises holes arranged on a triangular lattice, with a central hole being omitted from the structure to form a waveguiding core 1105. The pitch of the holes in the cladding region of the fibre is 1.025 microns.

The six innermost holes, adjacent to and surrounding core 1105, consist of four larger holes 1140, having a diameter-to-pitch ratio of 0.8848 and two smaller holes 1150, having a diameter-to-pitch ratio of 0.8627.

5 The twelve next-innermost holes, adjacent to and surrounding holes 1140, 1150 include two small holes 1130, having a diameter-to-pitch ratio of 0.4861. The remaining ten holes of those twelve (such as hole 1120) have a diameter-to-pitch ratio of 0.6481.

10 The remaining holes (such as hole 1110) in the structure are of a uniform size, having a diameter-to-pitch ratio of 0.741.

The beat length of the fibre is primarily determined from the symmetry breaking in the first ring of holes 1140, 15 1150. It is notable that only a very small difference in hole size is required to produce significant DGD. The second ring of holes 1120, 1130 has a relatively weak effect on the beat length (and the difference in size between holes 1120 and 1130 can therefore be much larger) but can be used 20 to partially compensate the DGD incurred from the symmetry breaking in the first ring.

The dispersions D experienced by the two polarisation modes of the structure of Fig. 11 are very similar. The variation of D with wavelength is shown for wavelengths 25 between 1.5 microns and 1.6 microns by lines 1210 and 1220 in Fig. 12. For both polarisations, D decreases monotonically from approximately $-1000 \text{ ps nm}^{-1} \text{ km}^{-1}$ at 1.5 microns to approximately $-1600 \text{ ps nm}^{-1} \text{ km}^{-1}$ at 1.6 microns. At 1.55 microns, both modes experience a dispersion of about 30 $-1360 \text{ nm}^{-1} \text{ km}^{-1}$, with the difference between the modes being about $20 \text{ nm}^{-1} \text{ km}^{-1}$. Thus, both modes have approximately the correct dispersion properties to compensate standard SMF -28 fibre.

The DGD between the modes (line 1310 in Fig. 13) 35 decreases monotonically from about -2600 ps km^{-1} at 1.5

microns to -4100 ps km^{-1} at 1.6 microns. The beat length of the fibre of Fig. 11 is very short compared with standard Hi-bi fibre. It decreases monotonically (line 1410 in Fig. 14) from about 1.228 mm at 1.5 microns to about 1.166 mm at 1.6 microns. Such a short beat length causes DGD to be more significant than PMD, allowing DGD compensation schemes such as those shown in Figs. 8 to 10 to significantly improve the polarisation properties of the fibre.

Four examples of alternative device configurations are shown in Figs. 15 to 18. In each example, polarisation-maintaining microstructured fibre 1500 is also a DCF, although the device configurations would also be suitable for fibres which do not provide dispersion-compensation.

Examples of fibres according to the invention may be used in a dispersion compensation module (Fig. 15) to provide chromatic dispersion compensation with negligible polarisation mode dispersion. In the module, single mode-fibres 500 are connected to photonic crystal fibre 1500 by a taper regions 1520.

In the configuration of Fig. 15, two identical polarisation-maintaining microstructured fibres 1500, 1500' are spliced together, with the polarisation axes of one of the fibres being rotated by ninety degrees relative to those of the other fibre. The polarisation of light propagating in the fibre is therefore abruptly rotated by ninety degrees relative to the polarisation axes of the fibre at splice 1530. (As described above, such an arrangement is another alternative to the ways of swapping polarisation axes described with reference to Fig. 9 (a) and (b).)

Fibres 1500, 1500' are arranged inline with standard single-mode fibre (SMF) 1510, 1510'. A region of fibre 1520, 1520' is provided along the length of which holes in fibre 1500, 1500' are gradually collapsed to provide an adiabatic tapered transition to a length of standard single mode fibre (having a doped core and/or cladding region).

Such a configuration provides an elegant device that is realised entirely in optical fibres and provides bi-directional operation. Of course, any suitable means, such as a Grin lens assembly, may be used to couple light between 5 fibres 1500, 1500' and 1510, 1510' as an alternative to the all-fibre solution.

A pulse having an arbitrary, linear polarisation is propagating along standard telecomms single mode fibre 1510. The pulse passes through the taper region 1520 and enters 10 fibre 1500. In fibre 1500, the pulse will split into two components, one being linearly polarised along fast axis F and the other being linearly polarised along slow axis S. As the components propagate, the component linearly polarised along axis S will lag behind the other component. 15 However, after twist 1530, the component formerly polarised along axis S will be polarised along axis F. Twist 1530 is at the centre splice of fibres 1500, 1500' and therefore when the pulse components reach transition region 1520' at the end of the fibre, the component that was lagging prior 20 to the twist will have exactly caught up with the other component and so the original linear polarisation of the pulse as it left standard fibre 1510 will be restored as it enters standard telecomms fibre 1510'.

Photonic-crystal fibre 1500, 1500' provides anomalous 25 dispersion of 20 ps/nm/km. Provision of twist 1530 means that that dispersion compensation may be provided with almost no polarisation mode dispersion. This approach will also eliminate polarisation-dependent loss.

In the configuration of Fig. 16, a single length of 30 birefringent fibre 1500 is used, in conjunction with a circulator 1610 and a Principal State of Polarisation (PSP) exchange assembly 1600. Light passes along standard SMF 1510 and into the first port α of circulator 1610. It exits at the second port β where it is coupled, by Grin lens 1620,

to fibre 1500, in which it propagates to PSP exchange assembly 1600.

Assembly 1600 comprises a second Grin lens 1620, which couples light from the fibre 1500 to a quarter-wave plate 1640. Light passes through quarter-wave plate 1640, reflects from mirror 1630 and passes back through quarter-wave plate 1640 and Grin lens 1620. The double pass through quarter-wave plate 1640 rotates the polarisation of the propagating light by ninety degrees so that on its return trip through fibre 1500, DGD experienced on the outgoing trip is cancelled. The light is coupled back into port β of circulator 1610 by Grin lens 1620 and exits through the third port γ of the circulator 1610 to continue propagating along SMF 1510.

This configuration provides several advantages over the configuration of Fig. 15. There is no need for matching or trimming of the birefringent fibre because the initial propagation in the first polarisation and the compensating propagation in the rotated polarisation both take place in the same fibre 1500. Splice 1530 (which may cause time-delayed echoes if it is imperfect) is eliminated in this configuration. Only half of the length of the fibre 1500 is needed (as a single length is used twice). Back-reflections into SMF 1510 are suppressed by the use of circulator 1610.

However, disadvantages compared with the all-fibre solution are that the configuration of Fig. 16 is unidirectional, utilises bulk optical components requiring micro-assembly, utilises circulator 1610 (circulators are usually relatively costly and lossy), depends critically on the quarter-wave plate 1640 (the behaviour of which is of course itself wavelength-dependent), involves a large number of interfaces (and hence potentially a large loss) and allows backscatter to be fed forwards into SMF 1510.

A third configuration is shown in Fig. 17. This configuration also utilises circulator 1610 but is a 'ring'

arrangement rather than a reflective arrangement. Light passing from SMF 1510 into port α of circulator 1610 is coupled out of port β of circulator 1610 into port δ polarisation beam-splitter 1710. Beam-splitter 1710 splits the light into two orthogonal polarisation components, which are coupled by Grin lenses 1620 at ports ϵ , ζ into opposite ends of birefringent microstructured fibre 1500.

Fibre 1500 includes a slow twist 1700, such that its PSP axes are rotated by ninety degrees. Consequently, both polarisation components produced by the beam-splitter 1710 are coupled along the same PSP axis (e.g. the fast axis of fibre 1500). Therefore, in principle at least, no DGD can arise as both polarisations entering the splitter 1710 see the same optical path length in fibre 1500. Any light coupled into the undesired polarisation mode of the system (the undesired PSP) is effectively suppressed by the beam-splitter 1710. Light of, say, horizontal polarisation is transmitted through the beam-splitter 1710 through port ϵ and is gradually rotated by the twist 1700 in fibre 1500 to be vertically polarised when it returns to port ζ of splitter 1710 at the other end of fibre 1500. As the light is now vertically polarised, it is reflected in the splitter 1710 and returned through port δ to port β of circulator 1610.

Conversely, light of vertical polarisation is reflected in its first pass through the beam-splitter 1710, so that it passes out through port ζ (by which the initially-horizontally-polarised light enters). The vertically polarised light is rotated by twist 1700 to be horizontally polarised light when it return to port ϵ of splitter 1710. The light is then transmitted through splitter 1710 and returns to port β of circulator 1610.

In both cases the light then exits into fibre 1510 via port γ of circulator 1610.

This configuration suppresses back-reflections into fibre 1500. In contrast with the configuration of Fig. 16,
5 no quarter-wave plate or other potentially wavelength-dependent device is required.

A fourth possible configuration is shown in Fig. 18. This configuration is similar to that of Fig. 17, but the circulator has been eliminated. Rather all four ports δ - η
10 of beam-splitter 1710 are utilised in conjunction with two Faraday rotators 1800 (In contrast, the configuration of Fig. 17 utilises only three ports δ - ζ of the beam-splitter, with light of the undesired polarisation dumped out of the fourth port η , which is not shown in those Figs.).

15 Light is coupled into the first port δ of splitter 1710 by a Grin lens 1620. Again, each of the two polarisation components emerging from the beam-splitter passes along the same PSP axis in fibre 1500, albeit propagating in opposite directions. Faraday rotators 1800 are arranged such that
20 the net rotation seen by each polarisation component brings each component back to its original orientation. Thus, light of, say, vertical polarisation is reflected out of the second port ϵ of splitter 1710 and returns, after propagation through rotators 1800 and fibre 1500, back into
25 the third port ζ of splitter 1710 vertically polarised. It is therefore reflected by splitter 1710 out of the fourth port η and into the downstream portion of fibre 1500. Conversely, horizontally polarised light is transmitted from the first δ to third ζ ports of splitter 1710, propagates
30 through rotators 1800 and fibre 1500, and is transmitted from the second port ϵ to the fourth port η where it is re-united with the other polarisation component.

Again, perfect DGD performance is in principle possible, as only one PSP of the fibre 1500 is utilised. Elimination of circulator 1610 provides this configuration with an advantage over that of Fig. 17. However, a
5 disadvantage is that any polarisation polarised along the undesired PSP axis can re-enter fibre 1510.

The fibres described above and shown in Figs. 2 to 4 are examples of fibres that can be designed to exhibit a selected amount of dispersion, because they have a 'W-
10 profile', that is a first cladding region, surrounding and adjacent to the core region, and a second cladding region, surrounding and adjacent to the first cladding region, the first cladding region having an effective refractive index that is lower than the effective refractive index of the
15 second cladding region.

Other fibre configurations that can be designed to exhibit a selected amount of dispersion are also suitable for embodying the invention; for example, the fibre of Fig. 7 has a higher-index inner cladding region (inner-most
20 tubular region 740) and a lower-index second cladding region (surrounding ones of holes 730). Another example of a fibre configuration that can be designed to exhibit a selected amount of dispersion is a dual parallel core fibre. Any fibre exhibiting a high dispersion and that is also
25 polarisation-maintaining is suitable for embodying the invention.

Claims

1. An optical fibre, comprising a core region and a cladding region, characterised in that the fibre exhibits a selected amount of dispersion and in that it is also birefringent.
- 5 2. An optical fibre as claimed in claim 1, which has, in its transverse cross-section, a rotational symmetry of two-fold.
3. A fibre as claimed in claim 1 or claim 2 that exhibits form birefringence.
- 10 4. A fibre as claimed in any preceding claim that exhibits stress birefringence.
5. An optical fibre as claimed in any preceding claim, in which the cladding region comprises a first cladding region, surrounding and adjacent to the core region and a second
15 cladding region, surrounding and adjacent to the first cladding region, the first cladding region having a refractive index that is lower than the refractive index of the second cladding region.
6. A fibre as claimed in claim 5, in which the first and
20 second cladding regions are concentric rings.
7. A fibre as claimed in claim 5 or claim 6, in which the fibre comprises a third cladding region having an effective refractive index that is lower than that of the second cladding region.
- 25 8. A fibre as claimed any preceding claim that exhibits birefringence resulting from structures in the inner cladding region.
9. A fibre as claimed in any preceding claim that exhibits birefringence resulting from structures in the second
30 cladding region.
10. A fibre as claimed in any preceding claim, in which the core region contains elongate regions.

11. A fibre as claimed in claim 10, in which birefringence may result from a variation, having two-fold rotational symmetry, in that microstructure.
12. A fibre as claimed in any preceding claim, in which
5 the cladding region comprises a plurality of elongate structures having a first refractive index embedded in a matrix material having a second, different refractive index.
13. A fibre as claimed in claim 12, in which the effective refractive index of the part of the cladding region
10 surrounding and adjacent to the core region is lower than the effective refractive index of the core region.
14. A fibre as claimed in claim 12, in which the effective refractive index of the part of the cladding region
15 surrounding and adjacent to the core region is higher than the effective refractive index of the core region.
15. A fibre as claimed in any of claims 12 to 14, in which the core region is an elongate hole.
16. A fibre as claimed in any of claims 12 to 14, in which
20 birefringence is achieved by providing a variation in the cross-sectional area or the shape of the elongate elements, or in the material of, or the concentration of a dopant in, the elongate elements or the matrix material, or by any combination of those mechanisms.
17. A fibre as claimed in any of claims 12 to 16, in which
25 the elongate structures are circular in transverse cross-section.
18. A fibre as claimed in any of claims 12 to 17, in which the elongate structures are arcuate in transverse cross-section.
- 30 19. A fibre as claimed in claim 18, in which at least one of the arcuate structures subtends an angle of 30° or more about the core region.
20. A fibre as claimed in any preceding claim that includes
35 a structure at or near its mid-point that is arranged to interchange the polarisation axes of the fibre relative to

the polarisation direction of light propagating in the fibre, or vice versa.

21. A fibre as claimed in any preceding claim, which includes a plurality of structures arranged to interchange
5 the polarisation axes of the fibre relative to the polarisation direction of light propagating in the fibre, or vice versa.

22. A fibre as claimed in claim 20 or claim 21, in which the structure(s) comprise(s) a twist of 90° or an integer
10 multiple of 90° .

23. A fibre as claimed in claim 20 or claim 21, in which the structure(s) (each) comprise(s) a plurality of small twists.

24. A fibre as claimed in any preceding claim that is a
15 photonic crystal fibre.

25. A fibre as claimed in any preceding claim that exhibits normal dispersion at 1.55 microns.

26. A fibre as claimed in any of claims 1 to 24 that exhibits anomalous dispersion at 1.55 microns.

20 27. A fibre as claimed in any preceding claim, having a beat length of less than 1 cm.

28. A method of controlling chromatic dispersion and polarisation-dependent dispersion of a light pulse, comprising propagating the pulse through a fibre as
25 described in any of claims 1 to 27.

29. A dispersion compensator comprising a fibre as described in any of claims 1 to 23.

30. An optical device comprising a fibre as claimed in any of claims 1 to 20, further comprising a wave plate and
30 mirror arranged to rotate by 90° or an integer multiple of 90° the polarisation of light exiting the fibre and to return the light to the fibre.

31. An optical device comprising a beam-splitter, for splitting light into two orthogonal polarisation components,

and a polarisation-maintaining optical fibre; the device being arranged such that the two polarisation components propagate along the same path in the fibre but in opposite directions and such that the polarisation components both propagate in the fibre polarised in the same orientation relative to the principal state of polarisation (PSP) axes of the fibre.

32. A device as claimed in claim 31, in which the polarisation components both propagate in the fibre polarised in the same orientation relative to the principal state of polarisation (PSP) axes of the fibre because the fibre is twisted by 90° or an integer multiple of 90° .

33. A device as claimed in claim 31, in which the polarisation components both propagate in the fibre polarised in the same orientation relative to the principal state of polarisation (PSP) axes of the fibre because a wave-plate is arranged to rotate the polarisation of the polarisation components.

34. A device as claimed in any of claims 31 to 33, further comprising a circulator for coupling light from a single-mode fibre into the beam-splitter.

35. A device as claimed in any of claims 31 to 34, further comprising a plurality of polarisation-rotators, arranged to rotate each polarisation component such that a component that is reflected by the splitter into the fibre is, after propagation through the fibre, output from the splitter by reflection and a component that is transmitted by the splitter into the fibre is, after propagation through the fibre, output from the splitter by transmission.

36. A method of compensating chromatic dispersion in an optical system, comprising propagating light from the optical system through a fibre according to any of claims 1 to 23 or an optical device according to any of claims 30 to 35.

37. An optical system comprising a first, chromatically dispersive, optical fibre and a second, optical fibre, that is as claimed in any of claims 1 to 23, the first fibre being longer than the second fibre and the second fibre exhibiting a chromatic dispersion that compensates for the chromatic dispersion of the first optical fibre.
38. An optical fibre comprising a first longitudinal region and a second longitudinal region, the first and second regions each having a fast polarisation axis and a slow polarisation axis, characterised in that the polarisation axes of the first longitudinal region are rotated with respect to the polarisation axes of the second longitudinal region.
39. A fibre as claimed in claim 38, which is a photonic crystal fibre.
40. A fibre as claimed in claim 38 or claim 39, in which the polarisation axes are rotated because the fibre includes a twist.
41. A fibre as claimed in claim 40, in which the fast polarisation axis of the first region is aligned with the slow polarisation axis of the second region.
42. A fibre as claimed in claim 41, in which the twist occurs over a length of the fibre that is sufficiently short that light polarised along the fast polarisation axis of the first region is transferred without leakage loss to the slow polarisation axis of the second region.
43. A fibre as claimed in claim 40 or claim 41, in which the twist is at the centre of the length of the fibre.
44. A fibre as claimed in claim 40, in which the axes of the first region are rotated with respect to the axes of the second region by only a small amount.
45. A fibre as claimed in claim 44, in which the fibre contains a plurality of twists, such that there is at least one further longitudinal region having its axes rotated by

only a small amount with respect to the axes of an adjacent longitudinal region.

46. A fibre as claimed in claim 45, in which the axes of adjacent longitudinal regions defined by the twists are rotated in opposite directions.

47. A fibre as claimed in claim 45 or claim 46, in which the axes of adjacent longitudinal regions defined by the twists are rotated by angles of equal magnitude.

48. A fibre as claimed in claim 47, in which the longitudinal regions have a length that is equal to one half of their beat length.

49. A fibre as claimed in claim 48, in which the twists each occur over a length of the fibre that is sufficiently short that light is transferred without leakage loss between adjacent longitudinal regions.

50. A fibre as claimed in claim 38 or claim 39, in which the polarisation axes are rotated because the fibre comprises two spliced fibres that are rotated relative to each other at the splice.

51. A fibre as claimed in claim 50, in which the rotation is such that the fast polarisation axis of the first region is aligned with the slow polarisation axis of the second region.

52. A fibre as claimed in claim 50 or claim 51, in which the splice is at the centre of the fibre.

53. A fibre as claimed in any of claims 38 to 52, which is connected at each end to a single-mode fibre.

54. A fibre as claimed in claim 53, in which the connection is via a taper.

55. A fibre as claimed in any of claims 38 to 54 that exhibits anomalous chromatic dispersion.

56. A fibre as claimed in any of claims 38 to 55 that exhibits normal chromatic dispersion.

57. An optical coupler or splitter comprising a fibre according to any of claims 38 to 56.

58. An interleaver for a wave-division multiplexed optical signal comprising a fibre according to any of claims 38 to 55.

59. A dispersion compensation module comprising a fibre
5 according to claim 55 or claim 56.

60. A method of manufacturing an optical fibre for altering the polarisation of propagating light, comprising rotating a part of an optical fibre to create a first longitudinal region and a second longitudinal region, the first and
10 second regions each having a fast polarisation axis and a slow polarisation axis, the rotation being such that the polarisation axes of the first longitudinal region are rotated with respect to the polarisation axes of the second longitudinal region.

61. A method as claimed in claim 60, in which the rotation
15 is a rotation of 90° .

62. A method as claimed in claim 60 or claim 61, in which the fibre is a photonic crystal fibre.

63. A method as claimed in claim 61 or claim 62 in which the
20 rotation is achieved by heating a portion of the fibre and twisting the fibre in the heated portion.

64. A method as claimed in claim 63, in which the heating and twisting occurs during drawing of the fibre from a preform.

65. A method as claimed in claim 63 or claim 64, in which
25 the heating and twisting takes place after the fibre has been drawn from a preform.

66. A method as claimed in claim 61 or claim 62, in which
30 the rotation is achieved by providing a first fibre and a second fibre, the first and second fibres each having a fast polarisation axis and a slow polarisation axis, and splicing the first fibre and the second fibre together such that the polarisation axes of the first fibre are rotated with respect to the polarisation axes of the second fibre.

67. A method as claimed in claim 66, in which the first and second fibres are photonic crystal fibres.

68. A method as claimed in claim 66 or claim 67, in which the first fibre and the second fibre are provided by
5 cleaving a fibre into two portions.

69. A method of propagating a light signal, comprising propagating the light along a fibre according to any of claims 38 to 56, wherein the polarisation of the light is rotated at the, or at the first rotation of the polarisation
10 axes of the fibre.

70. A method as claimed in claim 69, in which the polarisation of the light is in a first principal state of polarisation before reaches the, or the first, rotation of the polarisation axes of the fibre and it is in a second
15 principal state of polarisation when it leaves the rotation or the last such rotation.

71. A method of compensating for polarisation mode dispersion, comprising propagating a light signal along a first region of a fibre and then propagating the light
20 signal along a second region of the fibre of equal length to the first region, characterised in that the polarisation of components of the light signal is rotated between the first and second regions, relative to the fast and slow polarisation axes of the fibre.

25 72. A method as claimed in claim 71, in which the rotation results because the fast and slow polarisation axes of the first region are aligned with the slow and fast polarisation axes, respectively, of the second region.

73. A method as claimed in claim 71, in which the rotation
30 results from the effect of a rocking filter provided between the first and second regions.

74. A device comprising first and second fibre portions, both having a fast and a slow polarisation axis, there being provided a region optically coupling the first and second
35 fibre portions for coupling light from the first fibre

portion travelling in the fast and slow polarisation axes to the slow and fast polarisation axes respectively of the second fibre portion such that polarisation dependent effects of the first fibre portion are substantially
5 compensated for by polarisation dependent effects of the second fibre portion.

75. A device as claimed in claim 74, in which the polarisation dependent effect is polarisation mode dispersion.

1/15

Fig. 1

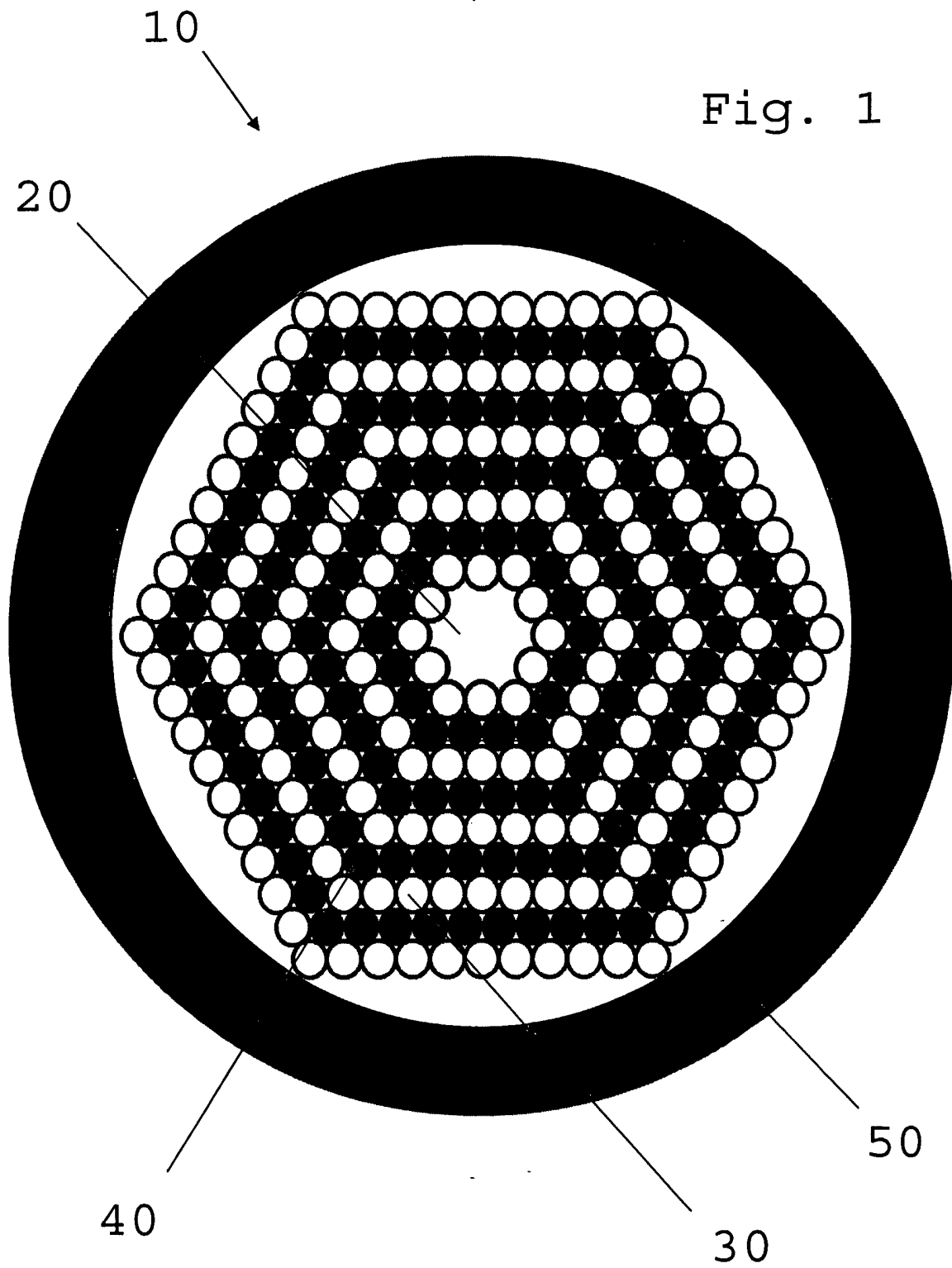

Fig. 2

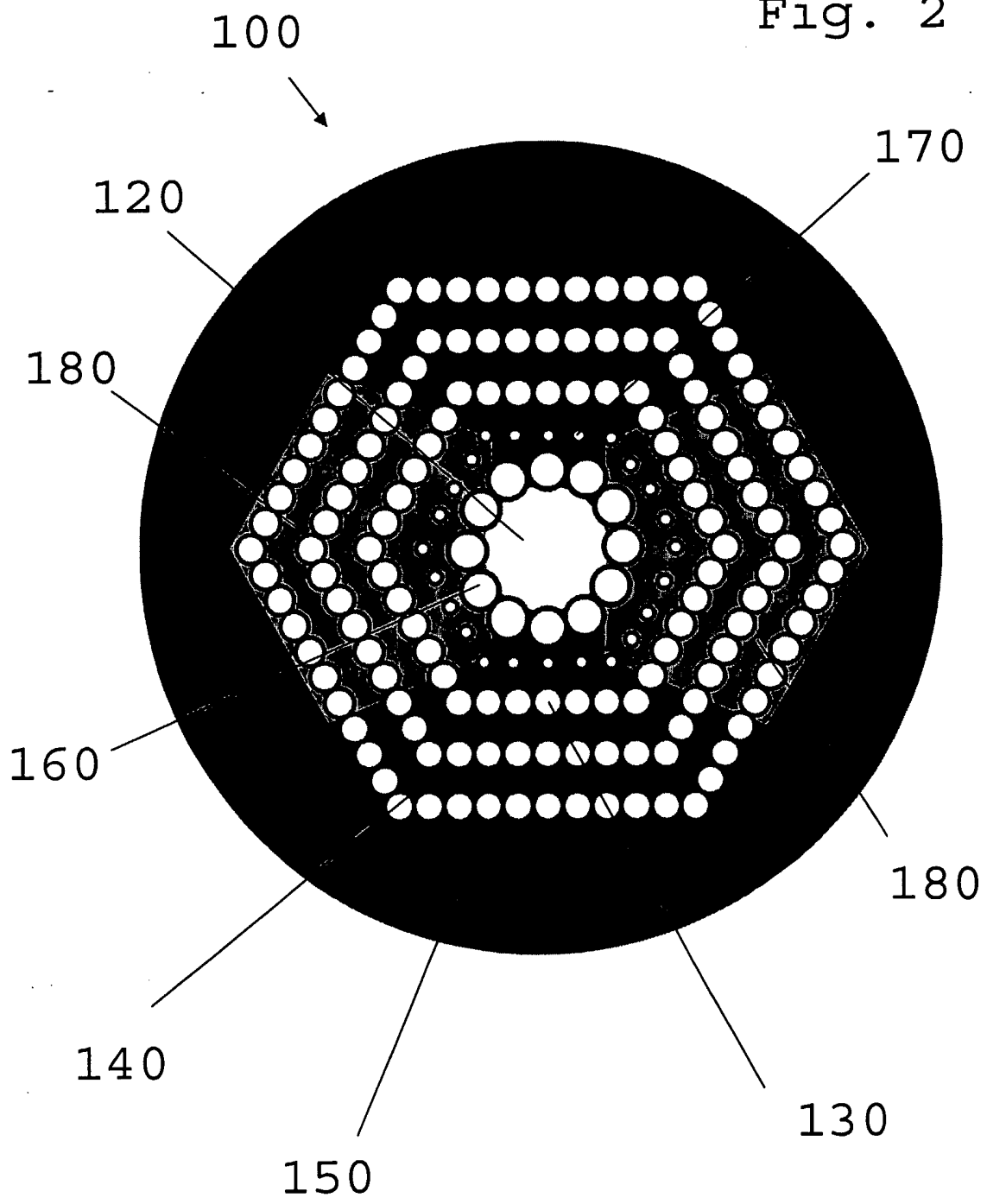

Fig. 3

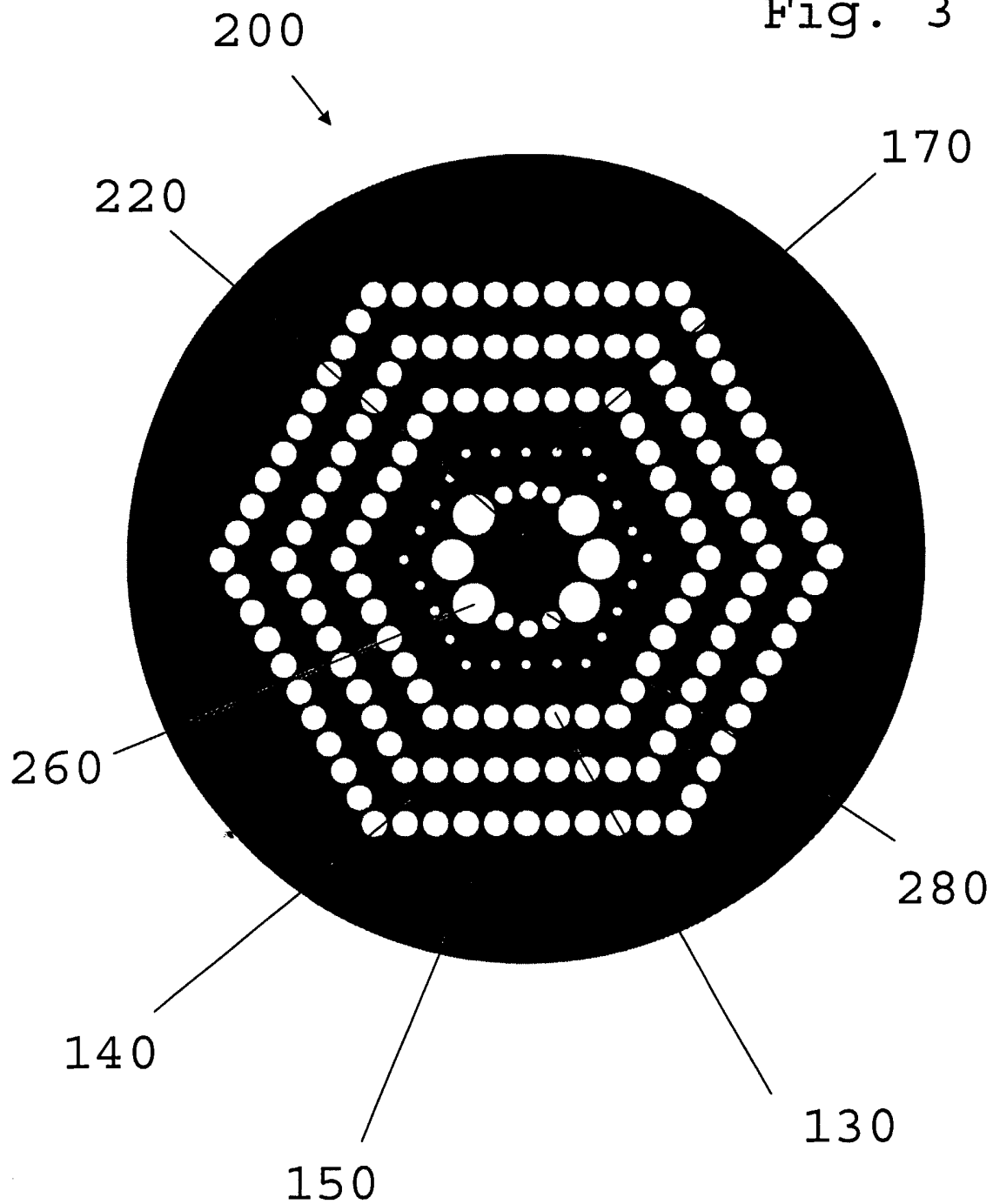
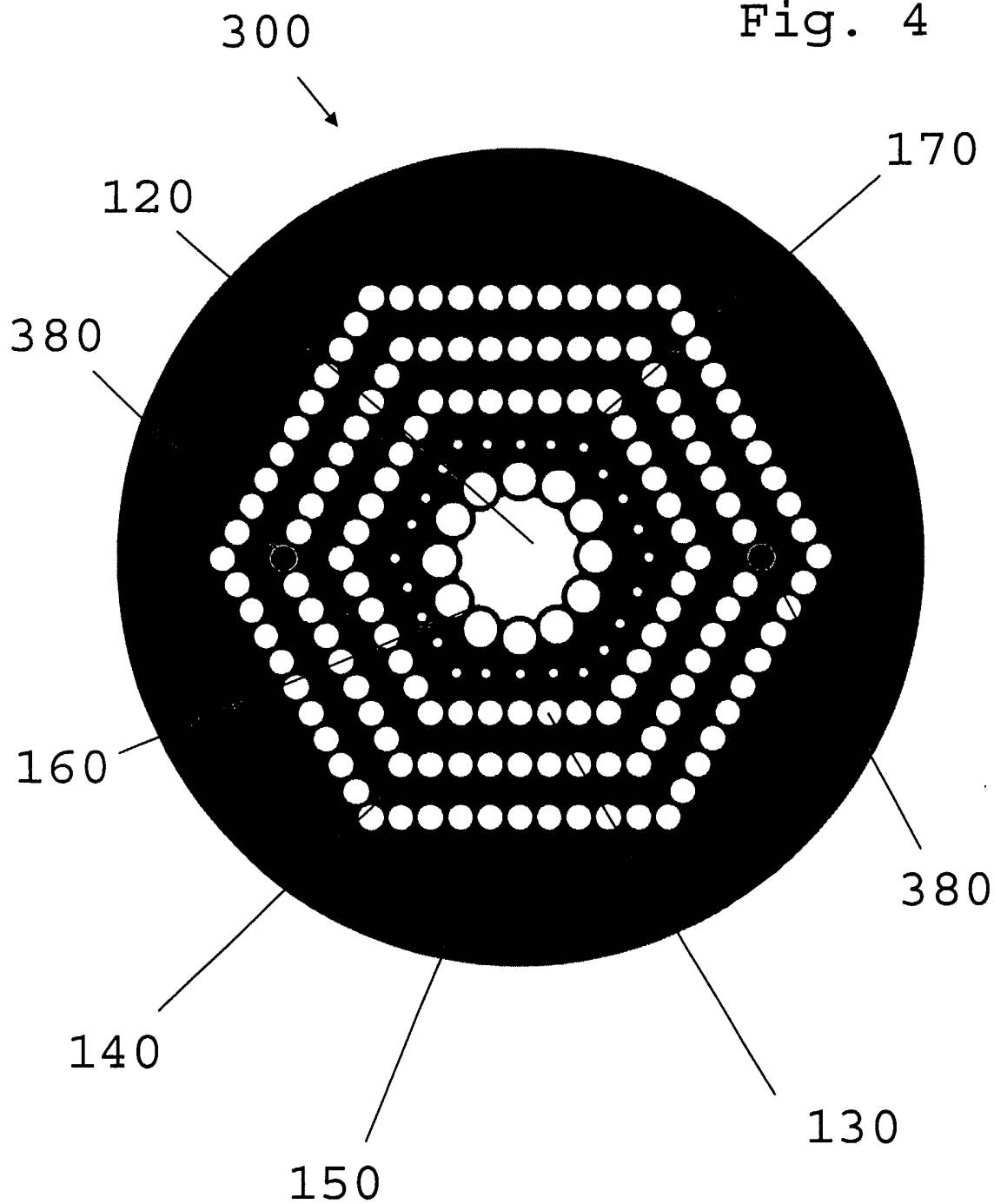
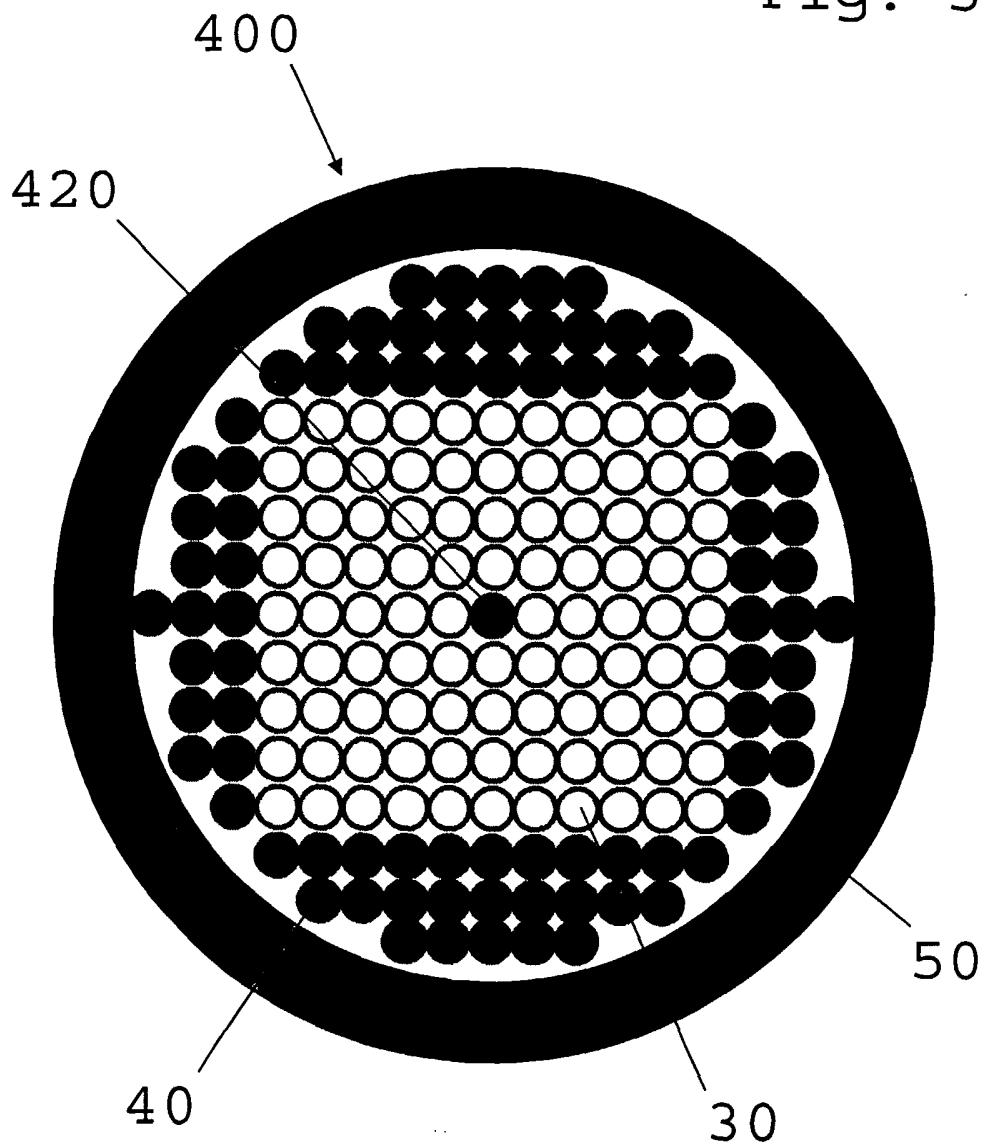

Fig. 4



5/15

Fig. 5



6/15

Fig. 6

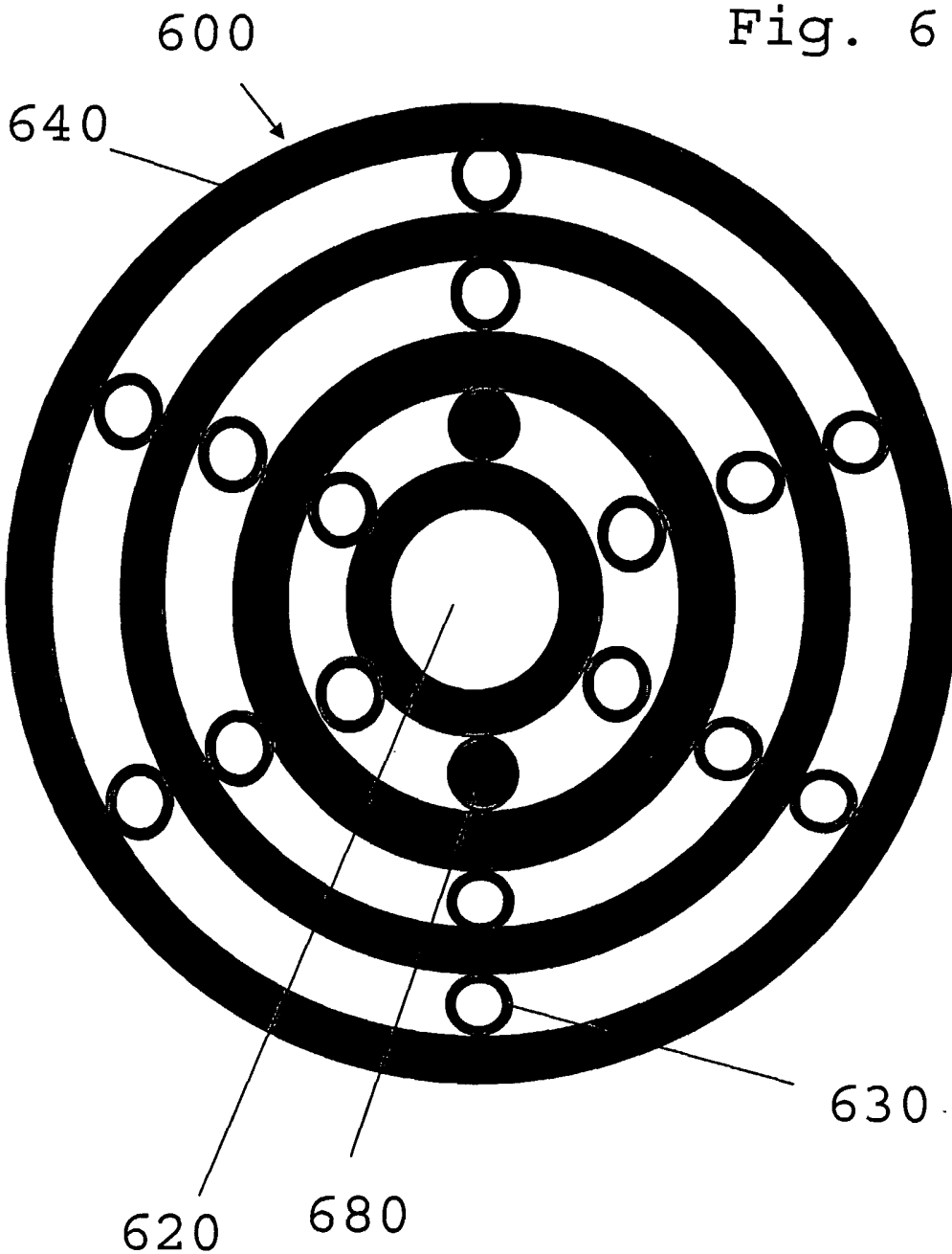

7/15

Fig. 7

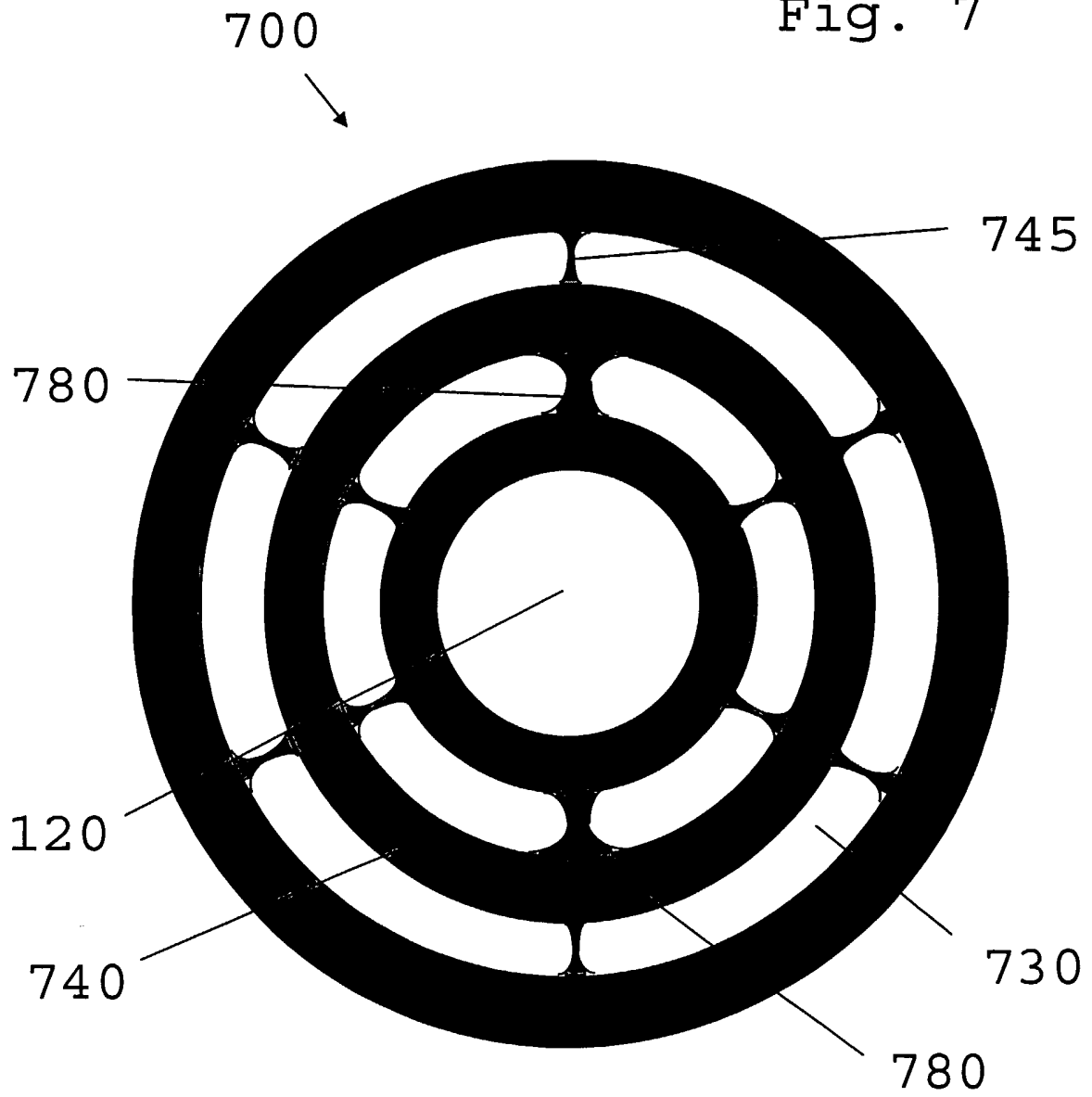

8/15

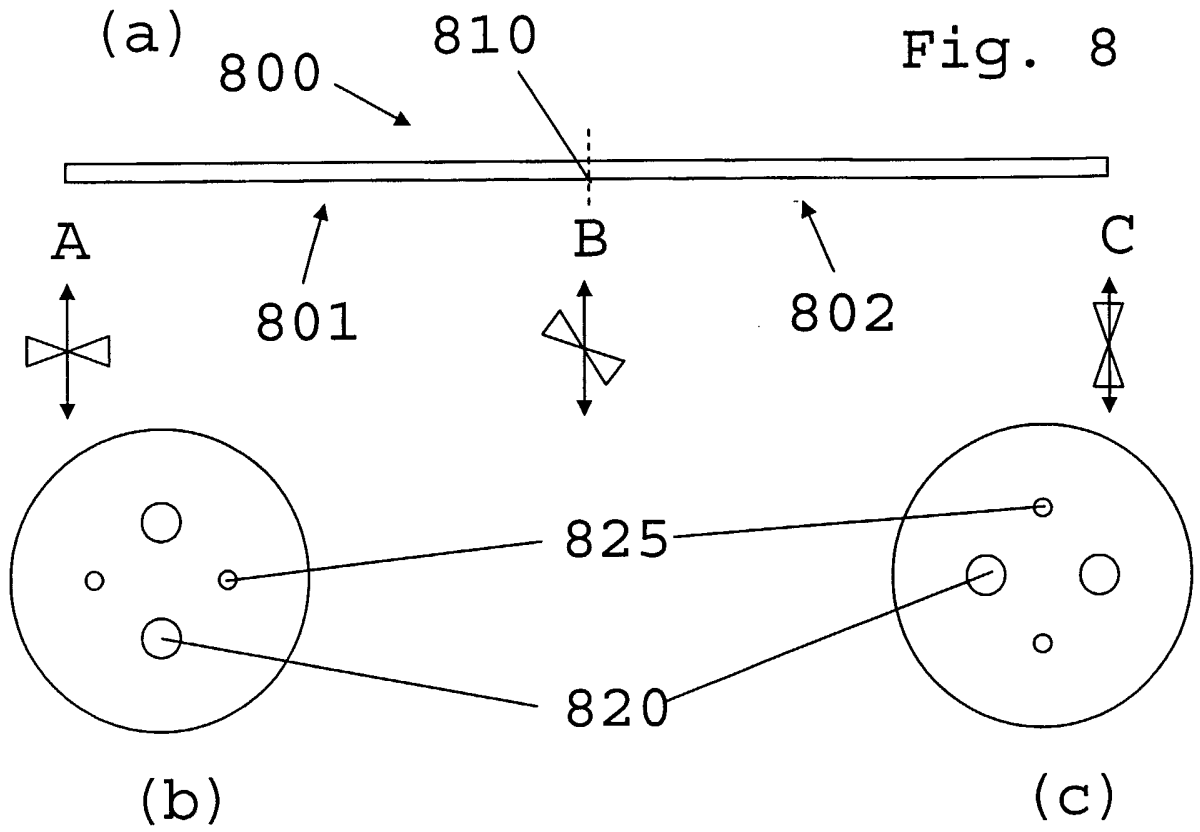
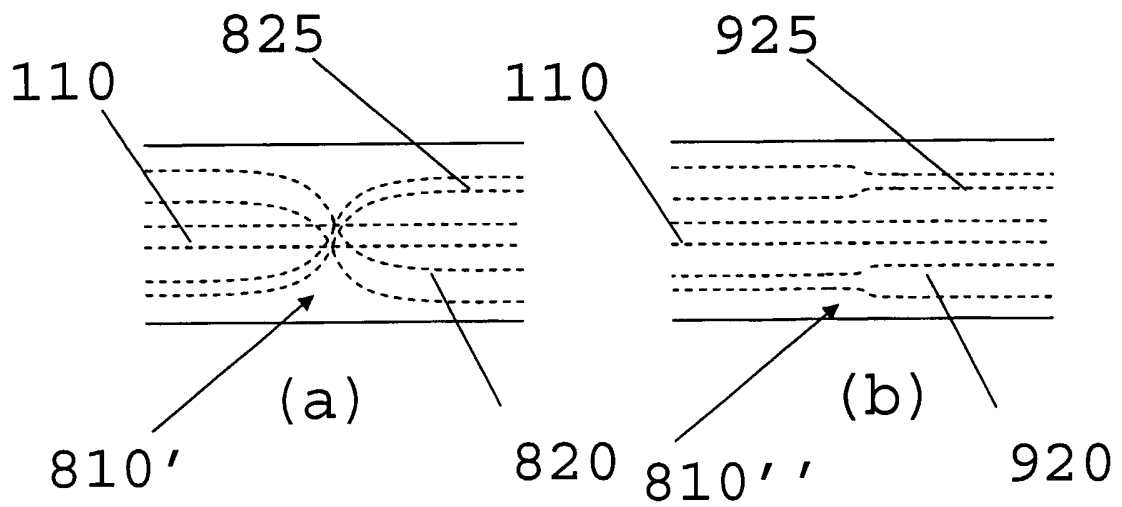
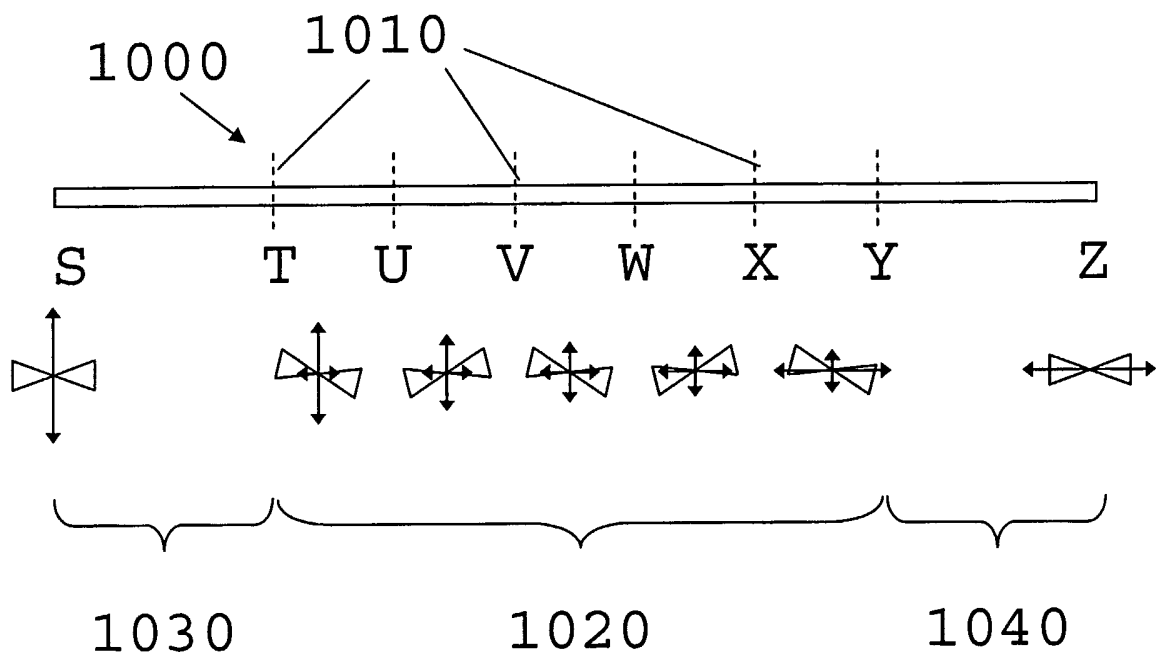

Fig. 9



9/15

Fig. 10



10/15

Fig. 11

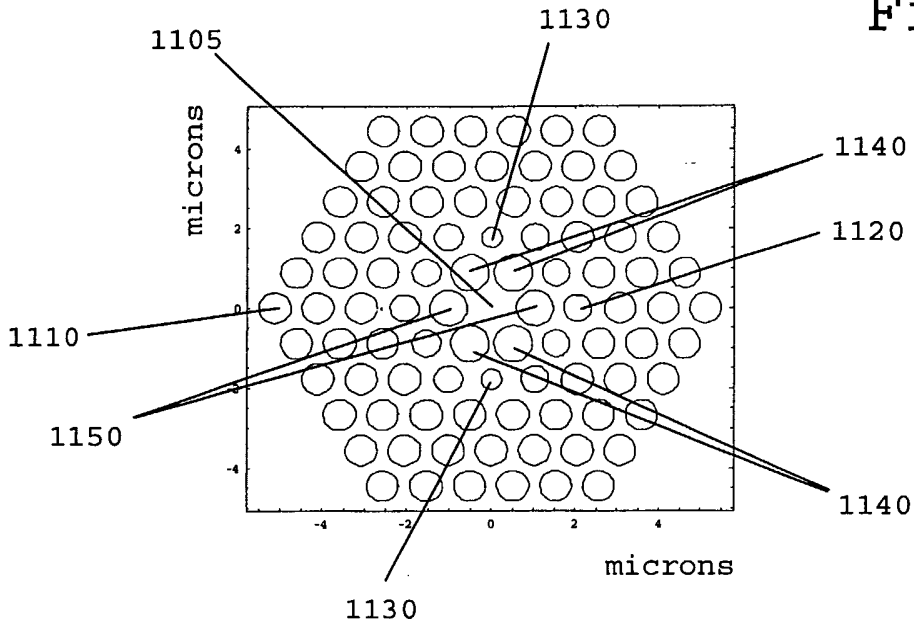
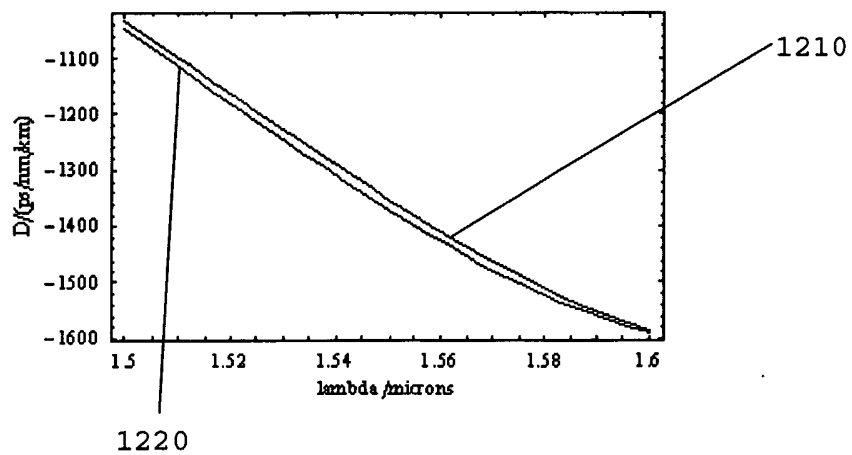

Fig. 12

Dispersion (D) vs. Wavelength (λ)



11/15

Fig. 13

DGD vs. Wavelength (λ)

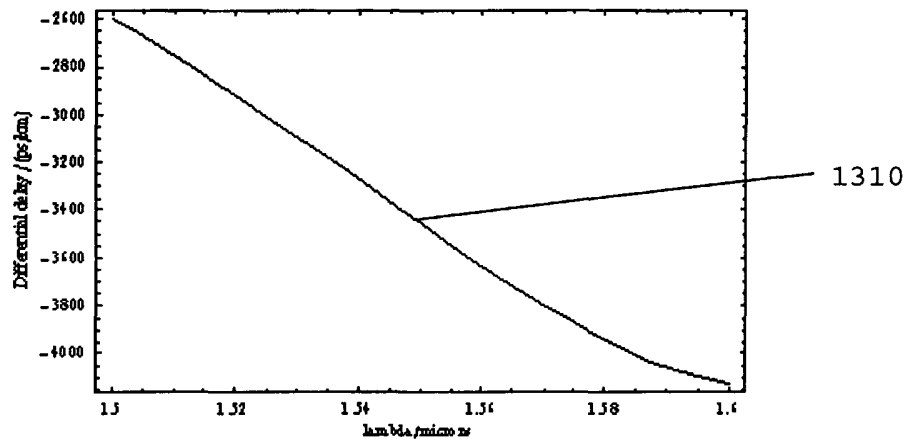
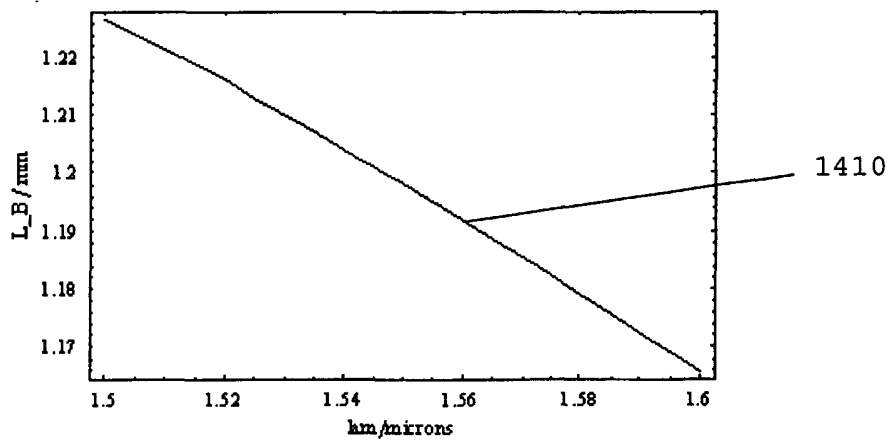

Fig. 14

Beat length (L_B) vs. Wavelength (λ)



12/15

Fig. 15

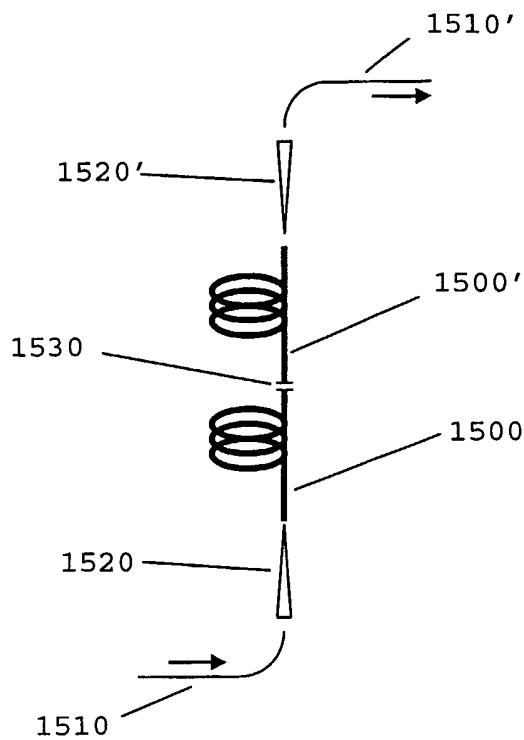
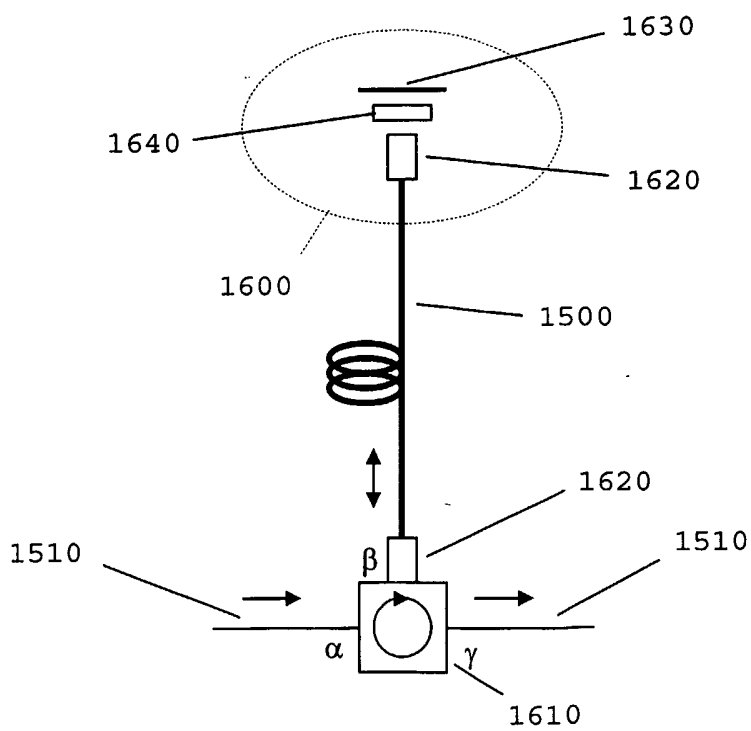

Fig. 16



13/15

Fig. 17

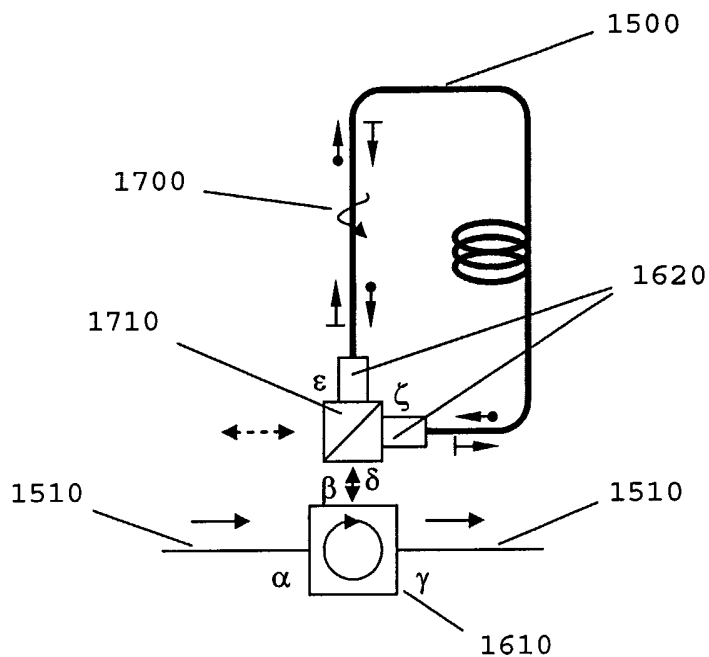
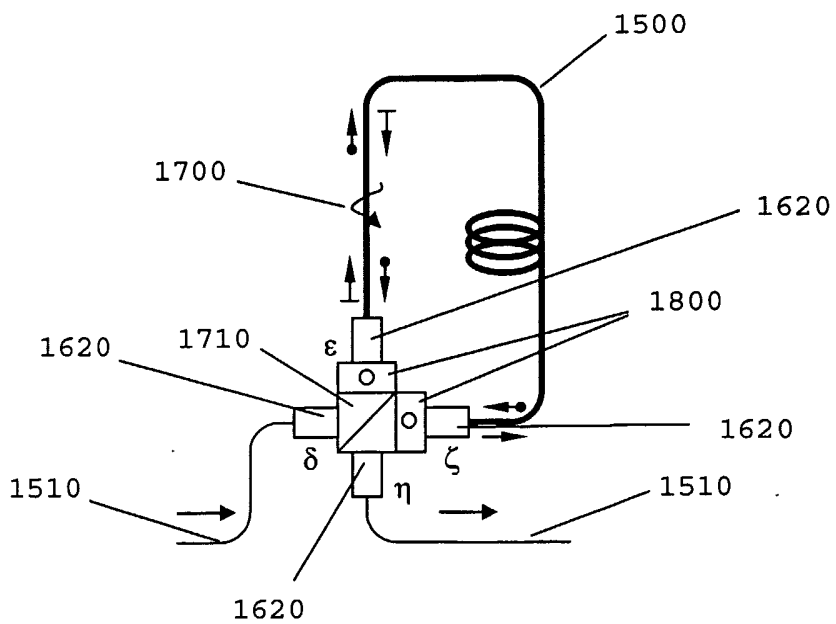
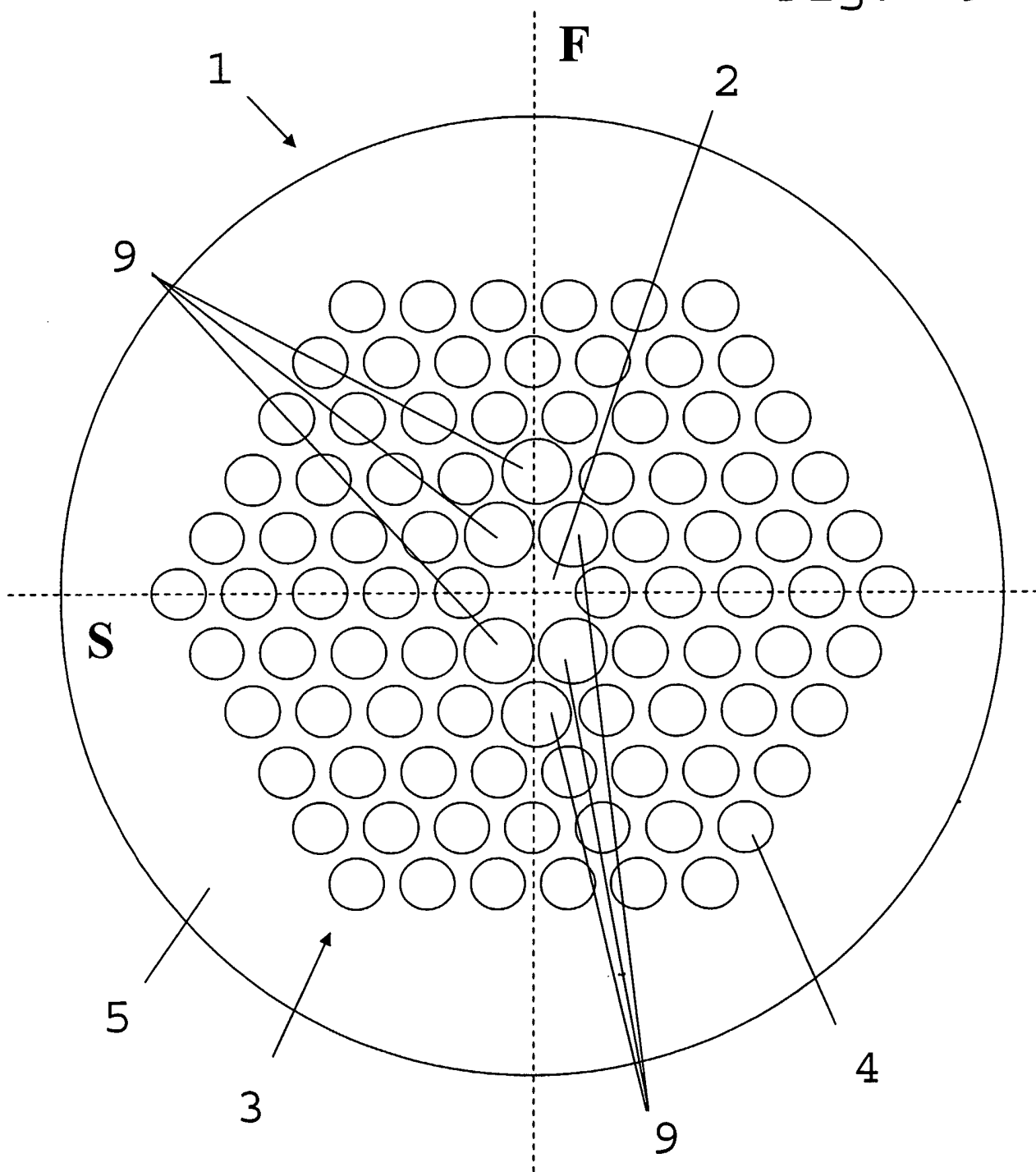

Fig. 18



14/15

Fig. 19



15/15

Fig. 20

