

(19) World Intellectual Property Organization
International Bureau



(43) International Publication Date
20 August 2009 (20.08.2009)

PCT

(10) International Publication Number
WO 2009/102718 A1

- (51) International Patent Classification:
F24J 1/00 (2006.01) C09K 5/16 (2006.01)
- (21) International Application Number:
PCT/US2009/033676
- (22) International Filing Date:
10 February 2009 (10.02.2009)
- (25) Filing Language: English
- (26) Publication Language: English
- (30) Priority Data:
12/069,995 14 February 2008 (14.02.2008) US
12/322,596 4 February 2009 (04.02.2009) US
- (71) Applicant and
(72) Inventor: BOMMARAJU, Tilak [US/US]; 68 Dolphin Drive, Grand Island, NY 14072 (US).
- (74) Agent: ATKINSON, Robert, C.; Simpson & Simpson, PLLC, 5555 Main Street, Williamsville, NY 14221 (US).
- (81) Designated States (unless otherwise indicated, for every kind of national protection available): AE, AG, AL, AM, AO, AT, AU, AZ, BA, BB, BG, BH, BR, BW, BY, BZ, CA, CH, CN, CO, CR, CU, CZ, DE, DK, DM, DO, DZ, EC, EE, EG, ES, FI, GB, GD, GE, GH, GM, GT, HN, HR, HU, ID, IL, IN, IS, JP, KE, KG, KM, KN, KP, KR, KZ, LA, LC, LK, LR, LS, LT, LU, LY, MA, MD, ME, MG, MK, MN, MW, MX, MY, MZ, NA, NG, NI, NO, NZ, OM, PG, PH, PL, PT, RO, RS, RU, SC, SD, SE, SG, SK, SL, SM, ST, SV, SY, TJ, TM, TN, TR, TT, TZ, UA, UG, US, UZ, VC, VN, ZA, ZM, ZW.
- (84) Designated States (unless otherwise indicated, for every kind of regional protection available): ARIPO (BW, GH, GM, KE, LS, MW, MZ, NA, SD, SL, SZ, TZ, UG, ZM, ZW), Eurasian (AM, AZ, BY, KG, KZ, MD, RU, TJ, TM), European (AT, BE, BG, CH, CY, CZ, DE, DK, EE, ES, FI, FR, GB, GR, HR, HU, IE, IS, IT, LT, LU, LV, MC, MK, MT, NL, NO, PL, PT, RO, SE, SI, SK, TR), OAPI (BF, BJ, CF, CG, CI, CM, GA, GN, GQ, GW, ML, MR, NE, SN, TD, TG).

[Continued on next page]

(54) Title: HYDROGEN ELIMINATION AND THERMAL ENERGY GENERATION IN WATER-ACTIVATED CHEMICAL HEATERS

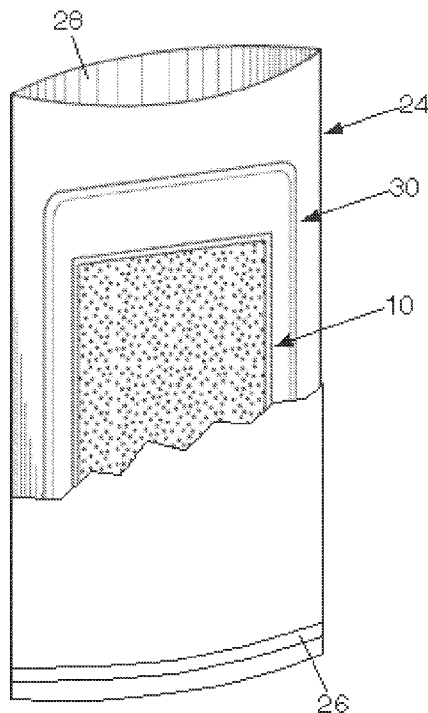

Fig. 2

(57) Abstract: Less hazardous methods for generating thermal energy for heating water, medical supplies or comestible products using improved flameless chemical heaters/flameless ration heaters by novel chemical or electrochemical means, each capable of suppressing the generation of hydrogen gas. Remote unit self-heating meals may be more rapidly heated by forming a reaction mixture comprising magnesium or a magnesium-containing alloy, and a hydrogen eliminator or suppressor, and introducing water to react the reaction mixture and generate a more rapid release of thermal energy sufficient to effectuate a more accelerated temperature rise and more rapid heating of medical supplies, water, rations or other comestible substances while simultaneously suppressing or eliminating the generation of potentially hazardous hydrogen.

Published:

— *with international search report (Art. 21(3))*

HYDROGEN ELIMINATION AND THERMAL ENERGY GENERATION IN WATER-ACTIVATED CHEMICAL HEATERS

TECHNICAL FIELD

5 [0001] The invention broadly relates to flameless chemical heaters, more specifically to magnesium based flameless chemical heaters, and even more particularly to magnesium based flameless chemical heaters arranged to eliminate or suppress the cogeneration of hydrogen.

BACKGROUND OF THE INVENTION

10 [0002] Flameless Chemical Heaters (FCH), also known as Flameless Ration Heaters (FRH), are used in Meal, Ready-to-Eat (MRE) packaging to provide hot meals to soldiers in the field or for warming or heating medical supplies or food rations in confined spaces (*e.g.*, tents, underwater shelters) or in remote locations where there is no heat source. These FCHs or FRHs are generally based on the reaction of magnesium with water to form magnesium
15 hydroxide and hydrogen which releases about 85 kcal of energy per mole of magnesium.

[0003] There are two types of MREs. The first is an individual meal for the soldier. The second one is a family-style meal for a group of 10-20 soldiers, called the Unitized Group Ration – Express (UGR – E). Both of these MREs use a Flameless Ration Heater (FRH) as the heat source for the hot meal. The temperature of a 250 gram individual MRE
20 entrée can be raised by 100°F in about 10 minutes using a 14g FRH. Typically, the process of heating food consists of adding about 40ml of water to the FRH by the military or other user, in order to activate the chemical reaction that produces the heat. Presently, the FRH consists of a magnesium, iron and salt mixture. The iron is used to activate the reaction of magnesium with water, whereas the salt prevents the formation of a magnesium oxide film on
25 the magnesium metal surface. The reaction products are magnesium hydroxide and hydrogen. With the individual MRE, the liberation of up to 13 liters of hydrogen gas has not been a substantial safety problem.

[0004] The Unitized Group Ration – Express (UGR – E) is a complete meal in a box and can feed small groups of eighteen soldiers. Again, the food is heated by using a
30 proportionally larger FRH that is activated by the addition or distribution of water. The problem associated with the release of hydrogen is significantly magnified with group meals. For a UGR – E weighing 28 pounds and requiring approximately 400 g of heater material,

the amount of hydrogen released is typically 13.5 cubic feet or 380 liters. Thus, the concern is that generation of this large quantity of hydrogen in a confined space will exceed the Lower Explosive Limit of 4%.

[0005] Accordingly, there is a need for an improved system for the elimination, or at least minimization of hydrogen generation in magnesium/water based flameless heaters.

SUMMARY OF THE INVENTION

[0006] It is therefore a principal object of the invention to eliminate or suppress the cogeneration of hydrogen in all types of magnesium-based FCHs, to prevent the release of hydrogen into the atmosphere and preventing potentially explosive situations by means of a novel process.

[0007] Thus, one principal aspect of the invention includes useful methods for generating energy for flameless heating, such as for foodstuffs, water, medical supplies, *etc.*, especially in the case of outdoor applications for camping, emergency, military applications all without the cogeneration of hazardous hydrogen by the steps of:

(i) forming a reaction mixture comprising at least magnesium or a magnesium-containing alloy and a hydrogen eliminator or suppressor, and

(ii) reacting the reaction mixture of (i) by introducing water to generate sufficient energy for heating an adjacently package substance or article, such as water, medical supplies, comestible substances, *etc.*, while simultaneously eliminating or suppressing the cogeneration of potentially hazardous hydrogen.

[0008] This inventor discovered a new class of useful hydrogen suppressors or eliminators for flameless heaters.

[0009] Accordingly, it is still a further principal object of the invention to provide novel methods and compositions of matter for the flameless generation of thermal energy, including heater devices and meal, ready-to-eat packaged meals wherein the methods and compositions not only suppress or eliminate the cogeneration of potentially hazardous hydrogen, but surprisingly, were discovered to provide a substantially accelerated temperature rise for more prompt heating of the packaged meal compared to other state-of-the-art flameless chemical heaters.

[0010] Generally, for purposes of this invention the expression "hydrogen suppressor" as appearing in the specification and claims is intended to mean any metal-containing oxidizing agent that is suitable for at least minimizing, and more preferably,

eliminating the cogeneration of hydrogen in the presence of magnesium or a magnesium-containing alloy. The metal of the metal-containing oxidizing agent, more specifically, is one having multiple valences, and includes as a preferred group, oxides of transition metals, such as manganese and/or oxides of ruthenium, and more particularly, manganese dioxide and
5 ruthenium dioxide, to name but a few.

[0011] It should be understood, there are other representative examples of reactants in addition to oxides of manganese and ruthenium as hydrogen suppressors or eliminators, which when mixed with magnesium and reacted with water at least minimize, and more preferably totally suppress the cogeneration of hydrogen, while effectively generating the
10 desired thermal energy. Generally, the useful hydrogen suppressors or eliminators are transition metal oxides that avoid the cogeneration of hydrogen in the reaction with magnesium or magnesium alloys. Representative examples include noble metals, such as platinum, iridium and rhodium. Other multivalent transition metal oxides include such members as iron, cobalt, nickel, silver, gold, tin, zirconium, hafnium, tantalum, lead, copper,
15 and so on.

[0012] Useful magnesium-containing alloys for the above reaction mixture can also include at least one alloying element, such as iron, cobalt, nickel, zinc, aluminum and mixtures thereof.

[0013] The subject invention also contemplates optional additives in practicing the
20 flameless heating methods disclosed herein comprising at least one member selected from hydrogen overvoltage suppressors, promoters, flowing agents and reaction activators.

[0014] As previously mentioned, it is still a further principal object of the invention to provide novel hydrogen suppressing or eliminating flameless, thermal energy generating chemical compositions. The compositions comprise reaction mixtures having at least:
25 magnesium and/or a magnesium-containing alloy, a hydrogen suppressor or eliminator that when mixed with water will initiate the flameless heat generating reaction.

[0015] Generally, the reactants are present in proportional amounts sufficient to generate heat for promptly raising the temperature of substances, products or articles, such as water, medical supplies, consumable rations, and the like, to the desired temperature within a
30 reasonable time period. As previously pointed out, it was surprisingly and unexpectedly discovered the novel hydrogen suppressor or eliminator compositions of the present

invention provide a substantially accelerated temperature rise over known flameless heat generating compositions comprising magnesium and water.

[0016] As previously mentioned, the hydrogen suppressing or eliminating flameless heat generating compositions may have other optional reactants, such as a hydrogen
5 overvoltage suppressors, reaction promoters, flowing agents and reaction activators.

[0017] In addition to magnesium metal, the hydrogen suppressing, flameless heat generating reaction mixtures may also be prepared from alloys of magnesium, prepared from alloying metals, such as iron, cobalt, nickel, zinc, aluminum and mixtures of the same. Such alloys are known among skilled artisans, and are commercially available through ordinary
10 channels of commerce.

[0018] Besides magnesium, the flameless heat generating reaction mixtures, like the previously described methods, also comprise at least one hydrogen eliminator/suppressor, such as oxides of manganese and/or ruthenium, and more particularly, manganese dioxide and/or ruthenium dioxide in a sufficient amount to suppress the generation of hydrogen. This
15 includes other transition metal oxides like those previously discussed in connection with the methods of the invention.

[0019] It is yet a further principal object of the invention to provide for heater devices, such as trays and pouches comprising the hydrogen suppressing, flameless, heat generating compositions, particularly for heating water, food rations, including medical
20 supplies especially useful for camping and military applications. This is especially intended to include Meal, Ready-to-Eat military ration packaging comprising the above flameless heater devices.

BRIEF DESCRIPTION OF THE DRAWING

[0020] For a further understanding of the invention and its characterizing features
25 reference should now be made to the accompanying drawings wherein:

Fig. 1 is a top plan view of a porous sealed packet of flameless heat generating composition of the invention with a portion of the porous sealed cloth removed to show the milled composition;

Fig. 2 is a partial isometric view of a flameless heater containment pouch of
30 the invention with a portion of the front panel removed for an interior view of the pouch with the porous packet of heat generating powder and the food ration packet;

Fig. 3 is similar to that of Fig. 2, except the containment pouch has been placed in a containment box, and water is being introduced into the flameless heater containment pouch for initiating the generation of heat for heating the food packet in the pouch;

5 Fig. 4 is a side elevational view of the containment box with a sidewall of the box removed to show the arrangement of the flameless heater pouch with sealed food ration packet in the pouch like that of Fig. 3, and with water added, wherein the box is propped up at the open end to assure the water remains in contact with the porous packet of heat generating powder;

10 Fig. 5 is a plot illustrating the rate of temperature rise of the flameless heat generating composition of the invention relative to the rate of temperature rise of prior art composition;

15 Fig. 6 is a further plot of the rate of temperature rise of another embodiment of the flameless heat generating composition of the invention relative to the rate of temperature rise of a prior art composition;

Fig. 7 is a further plot of the rate of temperature rise of additional embodiments of the flameless heat generating composition of the invention relative to the rate of temperature rise of a prior art composition; and,

20 Fig. 8 is a further plot of the rate of temperature rise of yet another embodiment of the flameless heat generating composition of the invention relative to the rate of temperature rise of a prior art composition.

DETAILED DESCRIPTION OF THE PREFERRED EMBODIMENTS

[0021] The invention relates to novel methods and reaction mixtures/compositions for the generation of flameless heat mainly without the co-generation of potentially hazardous hydrogen previously associated with prior art methods and compositions. The methods of the invention employ at least one transition metal oxide powder, such as an oxide of manganese and/or ruthenium, for example, mixed with powdered magnesium or magnesium-containing alloy to generate flameless heat, free of, or with minimal cogeneration of hydrogen. The methods of the invention can be demonstrated by the following representative reaction scheme:

30



[0022] The reaction eliminates or suppresses hydrogen generation, or at least minimizes its cogeneration, while providing accelerated temperature rise over prior methods, *i.e.*, more spontaneous heat generation than the known $\text{Mg} + \text{H}_2\text{O}$ reaction, as will be demonstrated by the methods below currently used in flameless chemical heaters or flameless
5 ration heaters. It may be noted that the addition of CuCl_2 , NaNO_3 , and trichloroacetic acid to magnesium were believed to eliminate the hydrogen evolution reaction. However, NaNO_3 and trichloroacetic acid are not effective in fully suppressing hydrogen generation, and CuCl_2 in the MREs is not acceptable because of environmental and health considerations.

[0023] The novel chemical compositions of the present invention react and generate
10 sufficient heat for promptly heating water, medical supplies, consumable rations, and the like, without simultaneously generating hydrogen. Methods of the invention rely on a metallic element, *e.g.*, magnesium or alloy thereof, a hydrogen suppressor or eliminator, and water, the latter of which acts as a reactant and a medium for the reaction. Generally, the hydrogen suppressor or eliminator is a transition metal oxide, and include *inter-alia* noble and non-
15 noble metal oxides. Other useful representative oxides include PtO , IrO_2 , RhO_2 , Fe_2O_3 , Co_3O_4 , NiO , Ag_2O , Au_2O_3 , CuO , TiO_2 , ZrO_2 , HfO_2 , Ta_2O_5 and PbO_2 .

[0024] Optional additives for the hydrogen suppressing flameless heat generating chemical compositions and methods may include a hydrogen overvoltage suppressor, a promoter, flowing agent, activators, and the like.

[0025] The metallic element in the chemical composition that generates heat is
20 magnesium or magnesium alloy containing from about 0.001% to about 10% iron, cobalt, nickel, zinc, aluminum, either singly or in combination with each other. A preferred composition is pure or substantially pure magnesium with small or trace amounts of other metals, *e.g.*, <0.001% to about 0.1% of the alloying elements, iron, cobalt, nickel, zinc and
25 aluminum. One preferred hydrogen suppressor in the chemical composition is MnO_2 and RuO_2 . A preferred hydrogen suppressor may be either $\gamma\text{-MnO}_2$ or $\beta\text{-MnO}_2$, both known oxides, made either electrolytically or chemically by known methods, or from a naturally occurring ore that is treated. The amount of MnO_2 in the chemical composition is in ranges from about 1 to about 10 times the stoichiometric amount required for the $\text{Mg} + \text{MnO}_2$
30 reaction with water, the preferred amount being 1 – 10 times the stoichiometry.

[0026] The hydrogen overvoltage suppressor in the chemical composition may be a metal sulfide, the metal preferably being Fe, Co, Ni, or a highly electrically conductive

carbon, present in amounts ranging from about 0.001 to about 1%. The promoter in the chemical composition is preferably a carbon in particulate or powder form, present in an amount ranging from about 0.001 to about 20 percent-by-weight. The filler or flowing agent includes such representative members as silicon dioxide and calcium carbonate, and is present in an amount ranging from about 0.001 to about 10 percent-by-weight. They are effective in also promoting the reaction rate of the flameless heater reaction mixtures. Activators for the reaction mixtures include alkali metal halides, such as NaCl, magnesium halide salts, such as MgCl₂, MgBr₂, including Mg(ClO₄)₂, and so on. Additionally, activators for the reaction mixtures include thermally and electrically conducting, high surface area synthetic graphite and other conducting carbon materials. An example of a suitable synthetic graphite includes Asbury 4827, produced by Asbury Graphite Mills, Inc., of Asbury, NJ, while suitable conducting carbons include Asbury TC 307, also produced by Asbury Graphite Mills, Inc., KETJENBLACK® (such as EC600JD), produced by Akzo Nobel Polymer Chemicals LLC, of Chicago, IL, BLACK PEARLS® 2000 or 1300, both produced by Cabot Corporation, Alpharetta, GA. The amount of activator can vary in the range from about 0.001 to about 50%. One preferred activator is MgCl₂, the other being electrically conductive carbon.

[0027] The reaction scheme set forth *supra* is an electrochemical corrosion reaction, the anodic reaction being the oxidation of Mg to form Mg²⁺ ions, the cathodic reaction being the reduction of MnO₂ to Mn₂O₃ and the electron transfer processes proceeding on the surface of MnO₂. It is for this reason that there is no need for a conducting electrolyte, such as a salt solution, to activate the reaction described *supra*. However, Mg is prone to form MgO and therefore, the reaction described *supra* does not proceed to completion unless an electrically conducting material such as carbon is added to the Mg/MnO₂ mixture and blended thoroughly to establish/provide good electrical connectivity between MnO₂ and Mg sites.

[0028] MgCl₂ serves the same purpose but in a different way. Thermodynamic potential-pH diagrams for an Mg/water system at various temperatures show that the pH at which Mg²⁺ is in equilibrium with Mg(OH)₂ shifts to lower pH values as the temperature increases. Thus, when MgCl₂ is added, the temperature rises to as high as 120-150°C, and facilitates the solubility of Mg(OH)₂ at pH=7, which is the pH of the water added to the reactants. Note that at pH=7 and at 25°C, the stable species is Mg²⁺, whereas at pH=7 and at

90°C, there is an equilibrium between these two species. This is the reason why addition of MgCl₂ promotes the accessibility of the blocked MgO sites. The pH value at which Mg²⁺ is in equilibrium with Mg(OH)₂ is strongly dependent on the activity of Mg²⁺ ions in the solution. It has been found that the higher the activity, the lower the pH value. We generally added MgCl₂ corresponding to an activity of >>1.

[0029] It will be understood, activators, *e.g.*, MgCl₂ and carbon, may be introduced into the flameless heater compositions of the invention by various methods. For example, one method provides for blending/mixing an activator, such as MgCl₂ or and/or carbon in particulate form into the milled magnesium and hydrogen suppressor or eliminator when preparing the reaction mixture, before introducing the water reactant. Alternatively, an aqueous solution of the MgCl₂, *e.g.*, 5 to 7 M solution of the activator in the water reactant (45 to 60 wt% solution), can be prepared and introduced together as a salt solution into the milled Mg and hydrogen suppressor or eliminator reaction mixture. However, the former method of blending the activator with the milled Mg and hydrogen suppressor or eliminator is generally more preferred because it is more effective in suppressing hydrogen than the latter method.

EXAMPLE 1

[0030] In order to demonstrate the details of the invention based on a Mg/MnO₂ + H₂O system according to the equation [1] below, the following experiment was conducted:



[0031] A 99.98% pure Mg metal sample of 500μ particle size from Superior Metal Powders, Franklin, PA, was used in this test, and contained trace amounts, *i.e.*, 85ppm Al, 4ppm Cu, 300ppm Fe, 250ppm Mn, 50ppm Na, 150ppm Si, 100ppm Zn and 50ppm Ca. In addition, a 300μ size γ-MnO₂ powder from Tronox, LLC, Henderson, NV, was used with a purity of 99%. The γ-MnO₂ contained trace amounts, *i.e.*, 8600ppm S, 2600ppm Ca, <100ppm Mg, <1000ppm Al, <100ppm Si, <100ppm Cl, 700ppm K, <1000ppm Cr and <100 Sn ppm.

[0032] The above Mg and γ-MnO₂ powders were used to make a batch sample in a stoichiometric ratio according to equation [1], above. Approximately 500g of the 300μ particle size MnO₂ and 69.44g of 500μ Mg were combined and placed in a mill. In this case the mill was a Vibrokinetic Energy (VKE) Mill, from Microgrinding System, Inc., Little Rock, AR, model 624 (diameter = 6" and tube length = 24"). This mill was operated with 36

stainless steel rods (6 with a diameter = 1", 30 with a diameter = 7/16") with a length of 24".

The sample mixture was introduced into the mill via a 2" diameter feed. All the screws and openings were tightened and secured prior to running the mill for 6 hours. At the end of the 6 hour milling period, the sample remained in the mill over night to cool. The sample was removed with a Nalgene scoop, transferred to a 600ml stainless steel beaker and stored in a desiccator with calcium sulfate as the dehydrating agent.

[0033] Following Fig. 1 of the drawings, polypropylene bag **10** was fabricated from porous filter cloth **12** (Unilayer 270), available from Midwest Filtration Company, Cincinnati, OH. The filter cloth was a 6-ply sonic bonded polypropylene laminate having a thickness of 22 mils (0.5588 mm), a weight of 91.6 g/m², an air permeability of polypropylene 635 l/m² /sec and a Mullen Burst strength of 80 psi. The porous filter cloth fabricated from polymeric fibers allows the transmission of water, and the release of gases while precluding the blockage of pores by the solid reactants and/or products owing to its depth loading characteristics. An 8" x 11" sheet of the filter cloth was used to fabricate bag **10** for containment of milled Mg/MnO₂ reaction mixture **20** *supra*. It should be appreciated that as described *infra* bag **10** may be constructed in a variety of ways. For example, filter cloth **12** may be constructed from a single layer of 6-ply sonic bonded polypropylene laminate as shown in Figure 1, or filter cloth **12** may be a dual layer bag consisting of two different filter cloth materials such as polyester fibers for one layer and polypropylene fibers for another layer, and either layer may be the inner or the outer layer of bag **10**. Additionally, filter cloth **12** may be constructed from multiple layers of polyester fibers, *e.g.*, four to six layers, or may be constructed as a dual composite fabric consisting of an inner layer of spunbond/meltblown/spunbond filter media containing 100% polypropylene and an outer layer of a 3-ply bonded polypropylene fiber cloth. An example of such an inner layer is Unipro 260-SMS which is made of white spunbond/meltblown/spunbond filter media containing 100% polypropylene with a thickness of 19 mils (0.4826 mm) and a weight of 2.60 oz/yd² (91.96 g/m²), with an air permeability of 17.1 cfm/ft² (86.9 l/m²/sec) and a Mullen Burst of 71 psi. It should further be appreciated that the foregoing examples are within the spirit and scope of the claimed invention.

[0034] First, filter cloth **12** was cut into a 6" x 8" sheet. The filter cloth was then made hydrophilic. One of two procedures and surfactants may be used in making the porous filter cloth hydrophilic. One method employs a "dip and nip" technique. This method

requires taking the porous hydrophobic cloth and dipping it into a 5% aqueous solution of surfactant. The excess surfactant is then squeezed off by passing the cloth through a pair of nip rollers. The second method provides for applying a dab of Pluronic-25R2 surfactant, from BASF Corp., Florham Park, NJ, on one or both sides of the cloth.

5 [0035] Hydrophilic porous filter cloth **12** was then fabricated into bag **10** by folding the treated 6" X 8" sheet in half. The bottom 4" of side **14** and 6" of side **16** were heat sealed to form the pocket or bag **10** with opening **22** on the top 4" of side **18** left open to allow for filling before applying the final heat seal. The heat seals were made using a Uline 8" impulse Sealer (H-163). 100g of the milled and dried Mg/MnO₂ powder **20** described
10 *supra* was then placed in the Unilayer 270 polypropylene bag **10** and opening **22** on the top sealed closed. This sealed flameless ration heater reaction mixture bag **10** was then placed in green non-porous "poly" bag **24** (Fig. 2) having bottom closure seal **26** and upper opening **28**. Poly bag **24**, fabricated with a polypropylene film, had a capacity sufficient for also holding 250g of water as "water test pouch" **30** used as a surrogate for a regular food ration packet.
15 Poly bag **24** containing the reaction mixture bag **10** and water test pouch **30** were placed in "chipboard box" **34** (Fig. 3).

[0036] 60ml of water **31** (Fig. 3) were then added to green poly bag **24** on the same side as the ration heater and the top of bag **24** was folded over (not shown). The green poly bag, and its contents in "chipboard box" **34** (Figs. 4) were held substantially horizontally with
20 the ration heater/reaction mixture bag **10** below water test pouch **30**. After 30 seconds, the system was set at a slight incline (Fig. 4), to prevent water loss, and allowed to react for 30 minutes. The temperature variation was recorded as a function of time and shown in Fig. 5, and tagged "Present Invention Example 1".

EXAMPLE 2

25 [0037] In order to compare the performance of the hydrogen suppressing, flameless heat generating composition of the invention prepared according to Example 1, a second sample of the known flameless heat generating composition comprising Mg and H₂O only was prepared.

[0038] 8g of 500 μ Mg/Fe, from Innotech Products, Inc., Cincinnati, OH as presently
30 used in a U.S. Army ration heater, was prepared according to the recipe in U.S. Pat. No. 5,611,329. This sample was placed in a "non-woven" bag material from Innotech Product, Inc. The Innotech bag material was a roll configured into four, 1" compartments distributed

through the length of the roll. 6" of this material was cut from the roll and the bottom was heat sealed with a Uline, 8" impulse sealer (H-163). Each of the four compartments was filled with 2g of the Mg/Fe and the ration heater was heat sealed closed (not shown).

[0039] The completed flameless ration heater was placed in a green polyethylene bag, from the U.S. Army, with a 250 g water pouch. After thirty seconds, 40ml of an aqueous solution of 0.25 M sodium chloride was poured between the water pouch and the flameless ration heater. The top of the green bag was folded over and the green bag with its contents was placed in a "chipboard" box (not shown). For approximately 30 seconds, the box system was held horizontally with the ration heater at the bottom. Then, the system was set at a slight incline to prevent water loss, and allowed to react for 30 minutes. The temperature variation was recorded as a function of time and shown in Fig. 5, tagged as "Prior Art Example 2".

[0040] Fig. 5, which plots test pouch temperature relative to time (minutes), demonstrates a significantly faster and higher (steeper) heat elevation temperature occurring with the flameless heating Mg/Mn oxide reaction mixture prepared according to Example 1 of the present invention relative to the known flameless heater composition of the prior art employing Mg/Fe reaction mixture without transition metal oxide (Example 2).

EXAMPLE 2A

[0041] 100g of 500 μ Mg/Fe, from Innotech Products, Inc., Cincinnati, OH as presently used in a U.S. Army ration heater, was prepared according to the recipe in U.S. Pat. 5,611,329. This sample was placed in an 8" x 11" bag made from the "non-woven" bag material from Innotech Product, Inc., that was configured into four, 2" compartments distributed through the length of the roll. Each of the four compartments was filled with 25 g of 500 μ Mg/Fe and the ration heater was heat sealed closed.

[0042] This completed ration heater was placed in a UGR-E heating tray, over which a 3500 g "water pouch" was placed. This assembly was placed in a card board box and then 330 ml of 1.5% NaCl solution was added. The card board box was then closed and the edges sealed with a tape. The temperature variation was recorded as a function of time over a 60 m period, and shown in Figures 7 and 8, tagged as "Prior Art Example 3".

EXAMPLE 3

[0043] In order to demonstrate a further embodiment of the subject invention which includes a metal halide activator, a further experiment was performed with the reactants: Mg + MnO₂ + MgCl₂ by means of the following protocol.

5 [0044] The milling procedure for the Mg/MnO₂ mixture was the same as that stated in Example 1. 45g of the milled Mg/MnO₂ mixture was mixed with 15g of 325 mesh MgCl₂, from Sigma-Aldrich, Inc., St. Louis, MO. This Mg/MnO₂/MgCl₂ mixture was placed in a dual layer bag consisting of two different filter cloth materials made of polyester fibers (Finon C305NW) and polypropylene fibers (Unilayer 270). Finon C305NW is made of
10 polyester fibers with a thickness of 7 mils (0.1778 mm) and a weight of 50.9 g/m², with an air permeability of 1,778 l/m²/sec and a Mullen Burst of 50 psi. This dual layer configuration is essential with Mg/MnO₂/MgCl₂ mixtures to provide thermal stability to the bag via the polyester fabric and the depth loading characteristic via the polypropylene, 6-ply, Unilayer. Both of the bag materials from Midwest Filtration were received in 8" x 11" sheets and cut
15 into 6"x 8" sheets. To make these materials hydrophilic, the "dip and nip" process of Example 1 was employed. To configure the pouch, the Finon polyester material was placed aside the smooth surface of the Unilayer polypropylene and both are folded in half to make a 4"x 6" pouch with the polyester inside the Unilayer polypropylene (not shown). A Uline 8" impulse Sealer (H-163) was used to heat seal the two materials together. The 6" side, parallel
20 to the fold and one of the 4" sides were sealed prior to adding the reaction mixture. An additional seal, parallel to the 6" side and down the center of the pouch was also added to make the pouch into two compartments. 30g of the Mg/MnO₂/MgCl₂ mixture was added to each of the compartments. The pouch was heat sealed closed and placed in a green "polybag" with a 250g water test pouch as a surrogate for a ration. 40ml of water was added
25 to the green bag on the same side as the ration heater. The top of the bag was folded over and the whole system was placed in a "chipboard" box. For approximately 30 sec, the box was held horizontally with the ration heater under the water pouch. Then the pouch was set at a slight incline for thirty minutes, as in Example 1. The temperature variation was recorded as a function of time and shown in Fig. 6, and tagged "Present Invention Example 3."

30 [0045] The performance of the FRH composition of the "Present Invention Example 3" was also tested relative to the "Prior Art Example 2" with the results demonstrated by Fig. 6 of the drawings.

[0046] Fig. 6 illustrating the performance of the FRH composition of the present invention (Example 3) comprising Mg and MnO₂, plus MgCl₂ activator also provided a significantly faster and higher (steeper) rise in the generation of thermal energy relative to the known flameless heater composition of the prior art employing Mg/Fe reaction mixture without transition metal oxide (Example 2).

BAG MATERIALS

[0047] As described above, bag **10** may be constructed in a variety of ways. As set forth in Example 1, bag **10** may be fabricated from porous filter cloth, such as Unilayer 270. In this example, the filter cloth is a 6-ply sonic bonded polypropylene laminate. Additionally, as set forth in Example 3, a dual layer bag consisting of two different filter cloth materials may be fabricated from polyester fibers, such as Finon C305NW, and polypropylene fibers, such as Unilayer 270. Furthermore, it has been found that bag **10** may also be fabricated from multiple layers, *e.g.*, four to six layers, of polyester fibers, such as Finon C305NW. Similar to the previously described fabrications, the multiple layers can be sonically bonded and made hydrophilic by the “dip and nip” process of Example 1. Each of these fabrications provides varying levels of thermal stability and depth loading capability so that fine particles are prevented from blocking the pores and preventing entry of water from outside to the reactants inside the bag material. In the dual layer configuration, the polyester fiber provides thermal stability to the bag while the polypropylene provides the depth loading characteristic. Moreover, porous filter cloth fabricated from polymeric fibers allows the transmission of water, and the release of gases while precluding the blockage of pores by the solid reactants and/or products owing to its depth loading characteristics.

[0048] It has been found that with when Unilayer-based ration heater pouches are used in combination with the present invention, a very small seepage of carbon and/or MnO₂ fines occurs before and after the reaction. Such leakage leads to an unappealing aesthetic appearance of the heater and stains the hands of the person handling the heater. It has been found that these issues may be eliminated by employing a dual composite fabric consisting of an inner layer of 1.5 oz, Unipro 260-SMS (spunbond/meltblown/spunbond filter media containing 100% polypropylene), and an outer layer of Unilayer 135 which is a 3-ply bonded polypropylene fiber cloth. The temperature-time profiles of the present invention in combination with the Unilayer 270 and the Unilayer 135/Unipro-SMS arrangements described above are shown in Figure 7 and labeled “Unilayer 270” and “Unilayer

135+Unipro-SMS”, respectively. The foregoing examples depicted in Figure 7 are shown with an UGR-E heater, and the test procedure is set forth in Example 20 below. A prior art example is also shown in Figure 7 and labeled “Prior Art Example 3”. It has been found that use of the above described Unilayer 135/Unipro 260-SMS fabric not only improved the heating rate, but also effectively precluded leakage of carbon and/or MnO₂ fines.

HYDROGEN GENERATION

[0049] The amount of hydrogen generated by the FRH reaction mixtures of the present invention (Examples 1, 3 and 20) was measured on a comparative basis with the FRH reaction mixture of the prior art (Example 2) by collecting off-gases and analyzing for hydrogen content by means of gas chromatography. The results are provided in Table 1 below:

Example	Solid Reactants	Liquid Reactants	Hydrogen Suppression
1	Mg/MnO ₂	Water	99%
2*	Mg/Fe	Water + NaCl **	0%
3	Mg/MnO ₂ /MgCl ₂	Water	94%
20	Mg/MnO ₂ /C	Water	97.1% 99.7%
20***	Mg/MnO ₂ /C	Water + NaCl	98.9%
* Results same as Mg/Fe/NaCl (0.6g) + Water			
** Water containing 40g H ₂ O + 0.6g NaCl			
*** Same composition as Example 20, however liquid reactant is water having 1.5% NaCl			

TABLE 1

15

EXAMPLE 4

[0050] The following example demonstrates the method for removing residual moisture (3.3% H₂O) from electrolytic manganese dioxide to near zero level for improving useful shelf-life of the reaction mixture.

[0051] In performing the process, 500g of MnO₂ is placed in an oven set to 400^oC for 2 hours and then heated at 110^oC for 24 hours. This MnO₂ sample is mixed with Mg powder and milled following the procedure disclosed in Example 1. The remaining steps of the process correspond to those disclosed in Example 1, containing Mg + MnO₂.

EXAMPLE 5

[0052] The following example demonstrates the method for removing residual moisture (3.3% H₂O) from electrolytic MnO₂ to near zero level in preparing a reaction mixture comprising Mg and MnO₂ (water-free), plus MgCl₂ activator for improving useful shelf-life of the reaction mixture.

[0053] In performing the process, 500g of MnO₂ is placed in an oven set to 400^oC for 2 hours and then heated at 110^oC for 24 hours. This MnO₂ sample is then mixed with Mg powder and milled following the procedure in Example 1. The remaining steps of the process are the same as those disclosed in Example 3, containing Mg + MnO₂+ MgCl₂.

EXAMPLE 6

[0054] The following example was performed to demonstrate the procedure for preparing a homogeneous reaction mixture that maximizes electrical contact of all the MnO₂ with Mg in the reaction mixture.

[0055] In performing the process, 300g of 60 μ γ -MnO₂, from Tronox, LLC, was mixed with the Mg powder and milled according to the procedure in Example 1. The remaining process steps corresponded to those disclosed in Example 1.

EXAMPLE 7

[0056] The following example was performed to demonstrate the procedure employed in preparing a reaction mixture comprising Mg + MgCl₂ with small particle size (60 μ) MnO₂.

[0057] In performing the process, 300g of 60 μ γ -MnO₂, from Tronox, LLC, was mixed with Mg powder and milled following the procedure in Example 3. The remaining steps are the same as that described in Example 3.

EXAMPLE 8

[0058] The following example demonstrates preparation of a reaction mixture according to present invention comprising magnesium with manganese dioxide except with very small average particle size of 0.8 μ .

[0059] In performing the process, 300g of 0.8 μ MnO₂ available from Sigma Aldrich can be mixed with Mg powder and milled following the procedure in Example 1, above. The remaining steps of the process can follow those disclosed in best mode Example 1.

EXAMPLE 9

[0060] The following example also demonstrates preparation of a flameless heater reaction mixture according to the present invention, but with ultra fine particulates of MnO₂ (0.8μ γ-MnO₂) hydrogen suppressant, plus MgCl₂ activator.

5 [0061] In preparing the reaction mixture, 300g of 0.8μ MnO₂, from Sigma Aldrich, is mixed with Mg powder and milled following the procedure of Example 3, above. The remaining steps for preparation of the reaction mixture correspond to those also described in best mode Example 3.

EXAMPLE 10

10 [0062] The following best mode example also demonstrates a further aspect of the invention except the improved flameless heater composition is prepared with two (2) times the stoichiometric amount of manganese dioxide.

[0063] In preparing the composition, 600g of MnO₂ from Tronox, LLC, is mixed with Mg particles and milled as described in working Example 1, *supra*. The remaining steps
15 correspond to those also described in Example 1.

EXAMPLE 11

[0064] The following best mode example also demonstrates a further aspect of the invention for preparing flameless heater compositions prepared with two (2) times the stoichiometric amount of manganese dioxide in combination with magnesium chloride
20 activator.

[0065] In preparing the reaction mixture/composition, 600g of MnO₂ from Tronox, LLC, is mixed with the Mg particles and milled in Example 1. The remaining steps correspond to those also described in Example 3.

EXAMPLE 12

25 [0066] The following example demonstrates a further alternative embodiment of the invention comprising for Mg + MnO₂ + 1% Zn⁰ metal, wherein an additional alloying metal, *i.e.*, zinc, is introduced into the composition to form surface alloyed magnesium metal particulates during the milling step.

[0067] In preparing the reaction mixture/composition, 500g of 300μ MnO₂ (same as
30 the MnO₂ disclosed in Example 1, procedure for Mg + MnO₂), 69.44g of 500μ Mg (same as the Mg⁰ described in Example 1 procedure for Mg + MnO₂) and 5g Zn⁰ particles, from Sigma Aldrich with a purity of 99.99%, were combined, placed in the VKE mill and milled

for 6 hours. The remaining procedure is the same as that described in Example 1, procedure for $Mg^{\circ} + MnO_2$.

[0068] This inventor found that the milling process is effective for: (i) mixing the ingredients to form a homogeneous reactive composition; (ii) assures desired intimate electrical contact between the ingredients, *i.e.*, $Mg + MnO_2 + Zn^{\circ}$ metal; (iii) is an effective means of forming surfaces alloyed with added metals, such as zinc, cobalt, nickel, iron, aluminum and mixtures of the same; and, (iv) also promotes better surface adhesion of the MnO_2 to the magnesium or alloyed magnesium.

EXAMPLE 13

[0069] This example discloses a flameless heating composition of the invention comprising a combination of both oxides of manganese and ruthenium in a 30% RuO_2 , 70% MnO_2 proportional range.

[0070] In preparing the composition, 48.61g of 500 μ Mg (same as disclosed in Example 1), 350g of 300 μ particle size of MnO_2 (same as the MnO_2 disclosed in Example 1 procedure for $Mg + MnO_2$) and 150g RuO_2 , 99.99% pure from Sigma Aldrich (12036-10-1), were combined, placed in the VKE mill and milled for 6 hours. The remaining procedure is the same as that described in Example 1.

EXAMPLE 14

[0071] This example discloses a flameless heating composition of the invention similar to Example 13, except the combination of oxides of manganese and ruthenium have been reversed wherein RuO_2 is present in 70% range, and the MnO_2 is present in a proportional range of 30%.

[0072] In preparing the composition, 20.83g of 500 μ Mg (same Mg disclosed in Example 1 and the procedure for milling $Mg + MnO_2$), 150g of 300 μ of MnO_2 (same MnO_2 disclosed in Example 1 and milling procedure for $Mg + MnO_2$ in Example 1) Mg, and 350g RuO_2 (same as the RuO_2 described in Example 13, $Mg + 30\% RuO_2 + 70\% MnO_2$), were combined, placed in the VKE mill and milled for 6 hours. The remaining procedure is the same as that disclosed in Example 1.

EXAMPLE 15

[0073] This best mode example demonstrates a flameless heating composition of the invention comprising RuO_2 as the sole hydrogen suppressing agent.

[0074] In preparing the composition, 45.50g of 500 μ Mg (same as the Mg disclosed in Example 1) and 500g RuO₂, (same as the RuO₂ disclosed in Example 13), were combined, placed in the VKE mill and milled for 6 hours. The remaining procedure is the same as that described in Example 1.

5 EXAMPLE 16

[0075] This example demonstrates a further embodiment of the invention wherein the flameless heater mixture includes in addition to Mg and MnO₂, 10% by-weight carbon to promote the rate of reaction and the generation of heat.

[0076] In preparing the reaction mixture/composition, 69.44g of 500 μ Mg (Same type of Mg disclosed in Example 1), 500g MnO₂ (same as the MnO₂ disclosed in Example 1) and 50g carbon from Cabot Corp., Boston, MA, available under the trademark Vulcan XC72R, Lot: GP-3860 were combined and placed in the VKE mill and milled for 6 hours. The remaining procedure for this composition follows the same protocols as disclosed in Example 1, above.

15 EXAMPLE 17

[0077] A further embodiment of the invention is presented wherein 1% Na₂S is introduced into the flameless heater composition Mg + MnO₂ composition as a hydrogen overvoltage suppressor. A metal sulfide may be incorporated into the composition as a fail safe in the event hydrogen is unexpectedly generated.

[0078] The flameless heater composition was prepared by mixing 69.44g of 500 μ Mg (same Mg disclosed in Example 1), 500g of MnO₂ (same MnO₂ disclosed in Example 1) and 5g Na₂S (from Sigma Aldrich), and placing the mixture in the VKE mill and milling for 6 hours. The remaining procedure corresponds to that described in Example 1, above.

EXAMPLE 18

[0079] Another embodiment of the flameless heater compositions of the invention includes the introduction of a filler/flowing agent, such as 2% SiO₂ to the magnesium /manganese dioxide.

[0080] This embodiment may be prepared by combining 69.44g of 500 μ Mg (the same Mg disclosed in Example 1) with 500g MnO₂ (the same MnO₂ disclosed in Example 1) and 10g of 20 μ SiO₂ (from Sigma Aldrich, purity = 99.5%) and placing the mixture in the VKE mill and milling for 6 hours. The remaining procedure for preparing corresponds to that disclosed in Example 1.

EXAMPLE 19

[0081] A similar flameless heater composition to that of Example 18 may be prepared using 2% CaCO₃ filler/flowing agent with the magnesium and manganese dioxide.

[0082] The reaction mixture/composition may be prepared by combining 69.44g of 5 500μ Mg (same Mg as disclosed in Example 1), 500g MnO₂ (same MnO₂ as disclosed in Example 1) and 10g of 20μ CaCO₃ (from Sigma Aldrich, purity = 99.0%), and placing the mixture in the VKE mill and milling for 6 hours. The remaining procedure corresponds to that described in Example 1.

EXAMPLE 20

[0083] A 99.98% pure magnesium powder of 200-300μ particle size from Superior 10 Metal Powders and containing 60 ppm Al, 50 ppm Cu, 300 ppm Fe, 700 ppm Mn, 50 ppm Si, 50 ppm Zn and 80 ppm Sn was used in this test. The 70-80μ γ-MnO₂, from Tronox, LLC, with a purity of 99% and contained 1.2% SO₄²⁻, 2600 ppm Na, 190 ppm Al, 310 ppm C, 35 ppm Fe and 400 ppm K. These two materials were used to make a batch sample, in a 15 stoichiometric ratio according to equation [1] above, along with 5% Asbury 4827 carbon, a synthetic graphite of <20-<30μ particle size, containing 1440 ppm Al, 865 ppm Ca, 2150 ppm Fe, 300 ppm Mg, 200 ppm Na and 2900 ppm Si.

[0084] Approximately 1100g of a mixture containing 919.2g MnO₂, 52.2g C and 130g Mg was weighed and placed in the Vibrokinetic Energy (VKE) Mill, from 20 Microgrinding System, Inc., model 624 (diameter = 6" and tube length = 24"). This mill is run with 36 stainless steel rods (6 with a diameter = 1", 30 with a diameter = 7/16") with a length of 24" as a stainless steel rod. The sample mixture is loaded into the mill via the 2" diameter feed. All screws and openings are tightened and secured prior to running the mill for 1.5 hours. At the end of 1.5 hours, the sample is left in the mill for 20 minutes to cool. 25 The sample is removed with a Nalgene scoop, transferred to a 1000ml stainless steel beaker and stored in a desiccator with calcium sulfate as the dehydrating agent.

[0085] A Unilayer 270 bag material from Midwest Filtration is used to contain the milled Mg/MnO₂ mixture. First, the bag material is cut into a 16.5" x 11" sheet and folded in half to make a 8.25" x 11" bag. Prior to adding the sample, one of the 8.25" sides and the 30 11" side is heat sealed to form a pocket. The task is done with a Uline, 8", Impulse Sealer (H-163). 450g of the milled Mg/MnO₂ mixture is placed in the Unilayer Pocket and sealed closed. This completed ration heater is placed in a UGR-E tray, over which the 3500g "water

pouch” is placed. This assembly is placed in a card board box and then 350ml of water is added. The card board box is then closed and the edges sealed with a tape. The temperature variation was recorded as a function of time over a 60 minute period, and is presented in Figure 8. The results of the mixture of this Example is labeled “Present Invention”, while the results of a prior art mixture is labeled “Prior Art Example 3”.

[0086] While the invention has been described in conjunction with various embodiments, they are illustrative only. Accordingly, many alternatives, modifications and variations will be apparent to persons skilled in the art in light of the foregoing detailed description, and it is therefore intended to embrace all such alternatives and variations as to fall within the spirit and broad scope of the appended claims.

What I Claim Is:

1. A method for generating energy for flameless heating, which comprises the steps of:
 - (i) forming a reaction mixture comprising at least magnesium or a magnesium-containing alloy, a hydrogen eliminator or suppressor, and
 - (ii) reacting the reaction mixture of (i) by the step of introducing water or an electrolyte thereto to generate sufficient thermal energy for heating an article or substance while simultaneously eliminating or suppressing the generation of hydrogen.
2. The method according to Claim 1, wherein the hydrogen suppressor is a transition metal oxide.
3. The method according to Claim 2, wherein the transition metal oxide is an oxide of manganese or ruthenium.
4. The method according to Claim 1, wherein the magnesium-containing alloy comprises at least one alloying element selected from the group consisting of iron, cobalt, nickel, zinc, aluminum and mixtures thereof.
5. The method according to Claim 1, wherein the reaction mixture (i) further comprises at least one member selected from the group consisting of a hydrogen overvoltage suppressor, a promoter, a flowing agent and a reaction activator.
6. The method according to Claim 5, wherein the hydrogen overvoltage suppressor is a metal sulfide, a carbon and said promoter is a carbon particulate; said flowing agent is silica or calcium carbonate, and the reaction activator is a salt selected from the group consisting of sodium halide, magnesium halide and magnesium perchlorate.
7. The method according to Claim 5, wherein said reaction mixture (i) is formed by milling said magnesium or magnesium-containing alloy with said hydrogen eliminator or suppressor, and mixing said milled reaction mixture with said at least one member selected

from the group consisting of said hydrogen overvoltage suppressor, promoter, flowing agent, and/or reaction activator prior to activating the heater reaction with water.

8. A hydrogen suppressing, flameless, heat generating chemical composition comprising
5 a reaction mixture having at least the following reactants: magnesium or a magnesium-containing alloy, a hydrogen suppressor and water, each of said reactants being present in a proportional amount to generate sufficient heat to heat water, medical supplies and/or consumable rations.
- 10 9. The hydrogen suppressing, flameless, heat generating chemical composition according to Claim 8, further comprising at least one member selected from the group consisting of a hydrogen overvoltage suppressor, a promoter, a flowing agent and a reaction activator.
- 15 10. The hydrogen suppressing, flameless, heat generating chemical composition according to Claim 8, wherein said magnesium alloy comprises at least one alloying member selected from the group consisting of iron, cobalt, nickel, zinc, aluminum and mixtures thereof.
- 20 11. The hydrogen suppressing, flameless, heat generating chemical composition according to Claim 8, wherein said hydrogen suppressor comprises oxides of manganese and/or ruthenium.
12. The hydrogen suppressing, flameless, heat generating chemical composition
25 according to Claim 11, wherein said oxide of manganese is γ -MnO₂ or β -MnO₂.
13. The hydrogen suppressing, flameless, heat generating chemical composition according to Claim 11, wherein the oxide of manganese is present in an amount ranging from 0.5 to about 10 times the stoichiometric amount required for the magnesium and the oxide of
30 manganese reaction with water to occur.

14. The hydrogen suppressing, flameless, heat generating chemical composition according to Claim 9, wherein the hydrogen overvoltage suppressor is a metal sulfide, the promoter is a carbon, and the activator is an inorganic salt.

5 15. The hydrogen suppressing, flameless, heat generating composition according to Claim 9, wherein the reaction activator is magnesium chloride present in an amount from about 0.001 to about 50 percent by-weight.

10 16. The hydrogen suppressing, flameless, heat generating composition according to Claim 15, wherein the reaction activator is mixed with milled magnesium-manganese dioxide mixtures prior to activating the heater reaction with water.

15 17. The hydrogen suppressing, flameless, heat generating composition according to Claim 9, wherein the reaction activator is a thermally and electrically conducting, high surface area synthetic graphite present in an amount from about 0.001 to about 50 percent by-weight.

18. The hydrogen suppressing, flameless, heat generating composition according to Claim 17, wherein the synthetic graphite is Asbury 4827.

20 19. The hydrogen suppressing, flameless, heat generating composition according to Claim 9, wherein the reaction activator is a conducting carbon present in an amount from about 0.001 to about 50 percent by-weight.

25 20. The hydrogen suppressing, flameless, heat generating composition according to Claim 19, wherein the conducting carbon is Ketjenblack, Black Pearls ® 2000, Black Pearls ® 1300 or Asbury TC 307.

30 21. The hydrogen suppressing, flameless, heat generating composition according to Claim 9, wherein the reaction activator is a conducting graphite or carbon present in an amount from about 0.001 to about 50 percent by-weight and the reaction activator is mixed with a magnesium-manganese dioxide mixture in a vibratory or ball mill for at least an hour.

22. A heater device comprising the hydrogen suppressing, flameless, heat generating chemical composition according to Claim 8.

23. The heater device of Claim 22 wherein the hydrogen suppressing, flameless, heat
5 generating chemical composition is enclosed within a bag comprising a filter cloth, wherein said filter cloth comprises a 6-ply sonic bonded polypropylene laminate.

24. The heater device of Claim 22 wherein the hydrogen suppressing, flameless, heat
10 generating chemical composition is enclosed within a dual layer bag comprising a first layer comprising polyester fibers and a second layer comprising polypropylene fibers.

25. The heater device of Claim 22 wherein the hydrogen suppressing, flameless, heat
generating chemical composition is enclosed within a multi-layer bag comprising a plurality
of layers of polyester fibers.

15

26. The heater device of Claim 22 wherein the hydrogen suppressing, flameless, heat
generating chemical composition is enclosed within a dual layer bag comprising an outer
layer of 3-ply bonded polypropylene fiber cloth and an inner layer of
spunbond/meltblown/spunbond filter media comprising polypropylene.

20

27. A meal, ready-to-eat package comprising the flameless heater device according to
Claim 22.

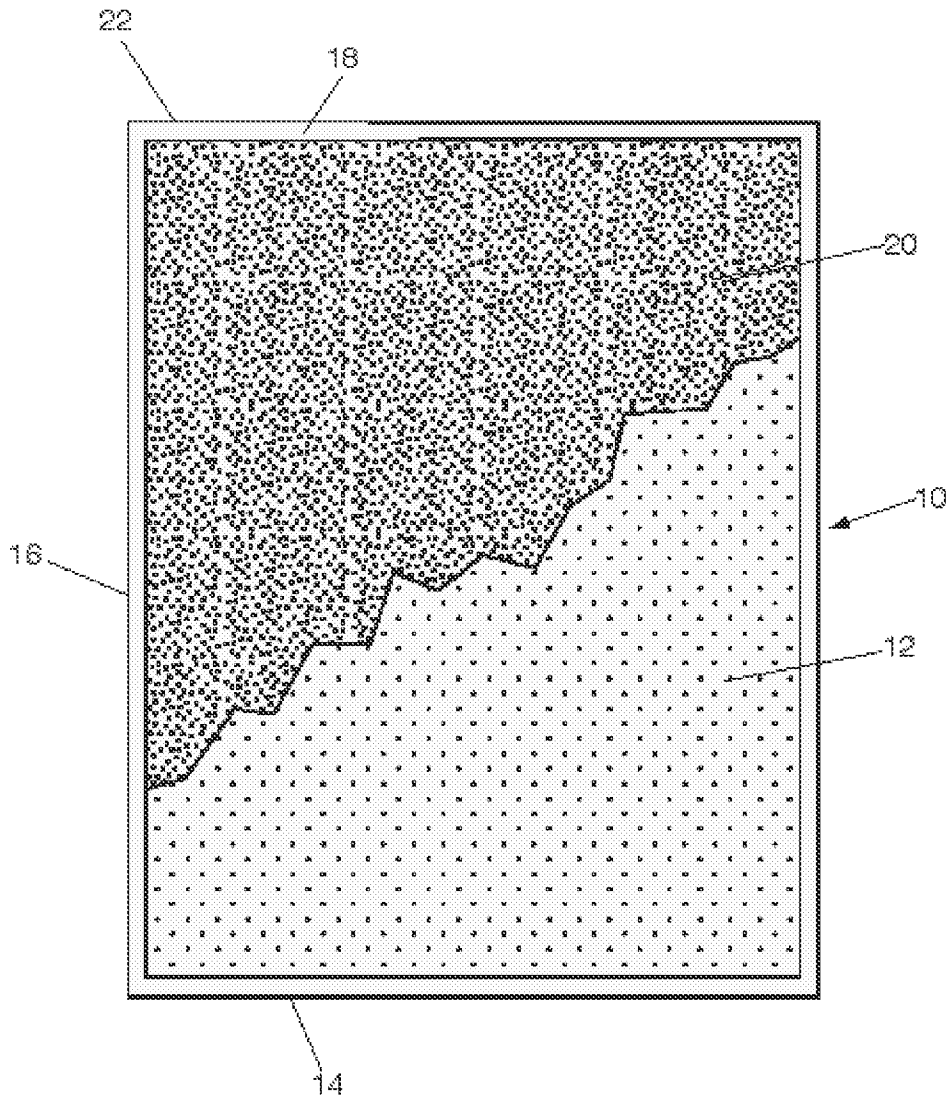

Fig.1

2/5

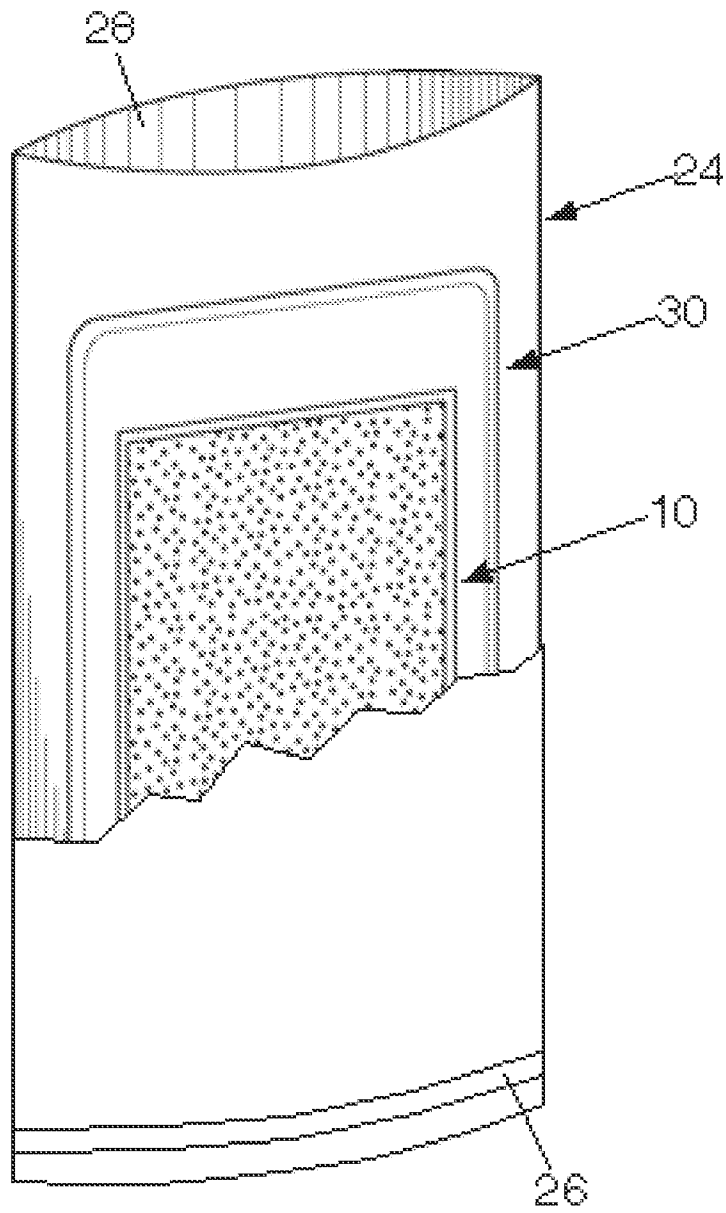

Fig. 2

3/5

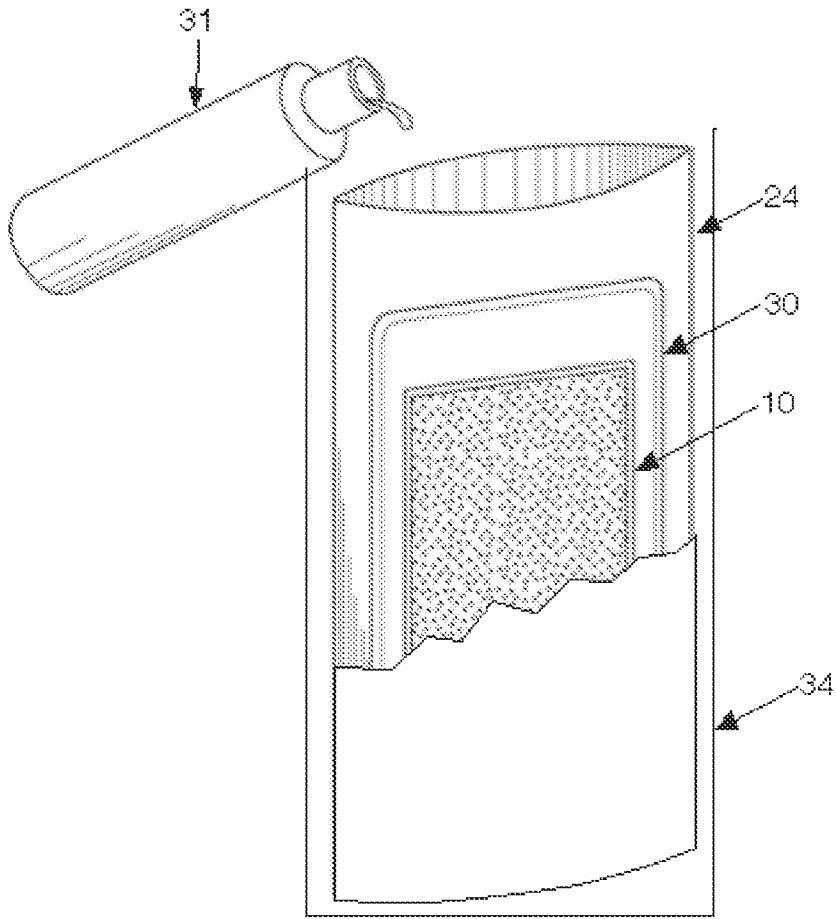

Fig. 3

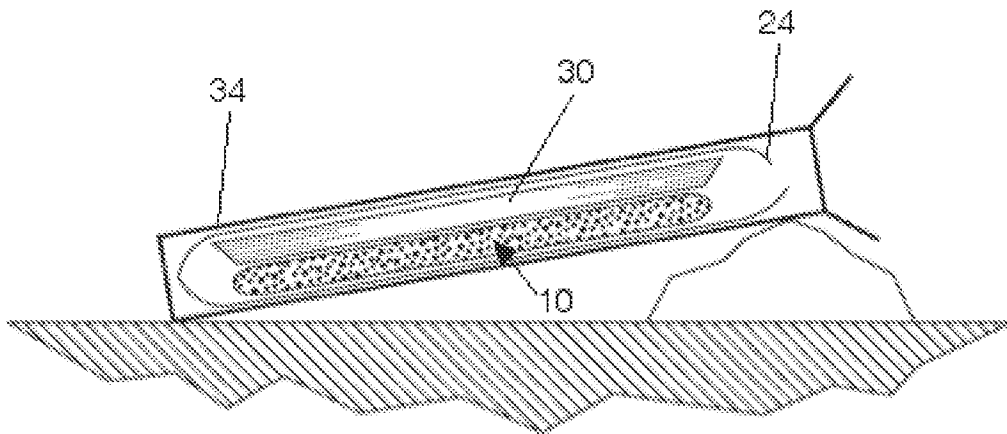

Fig. 4

4/5

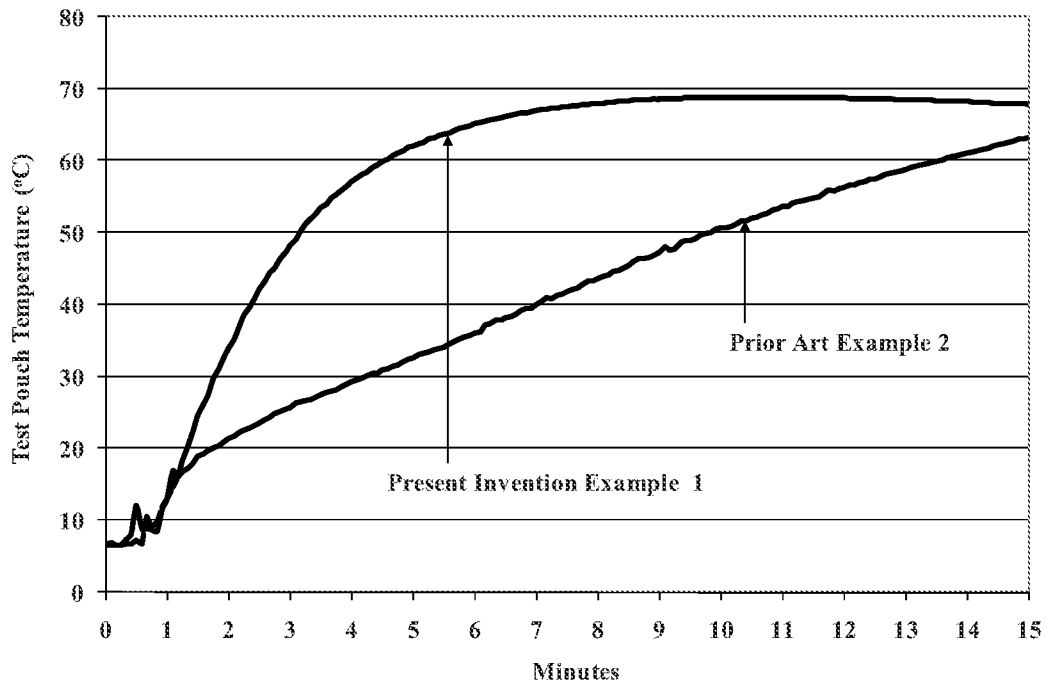

Fig. 5

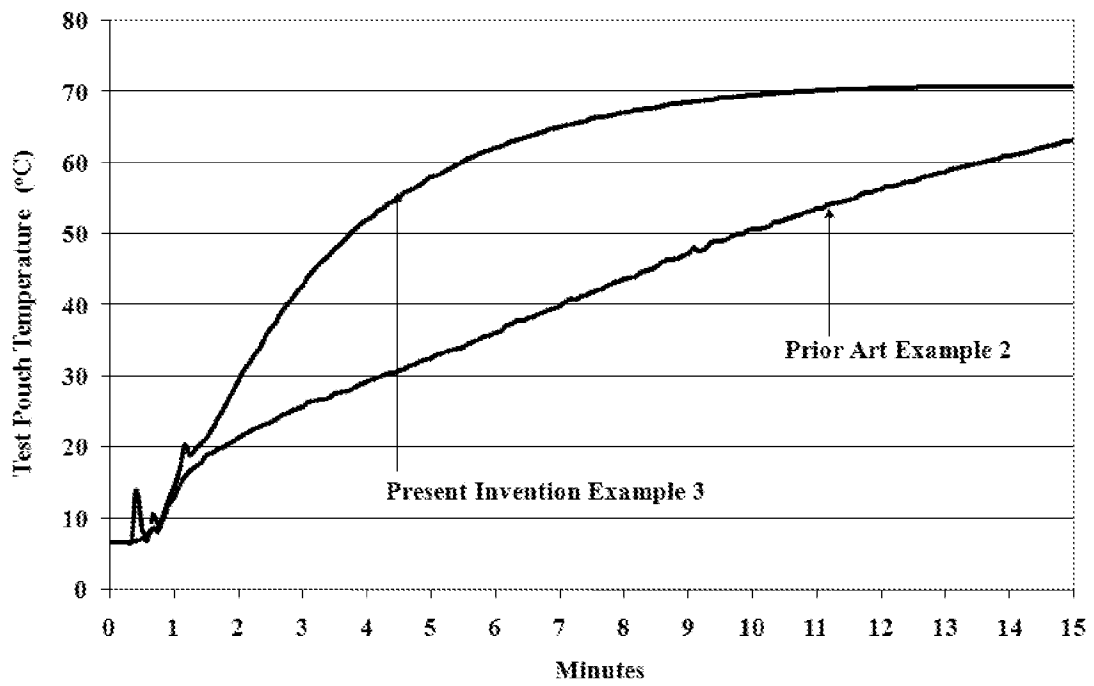

Fig. 6

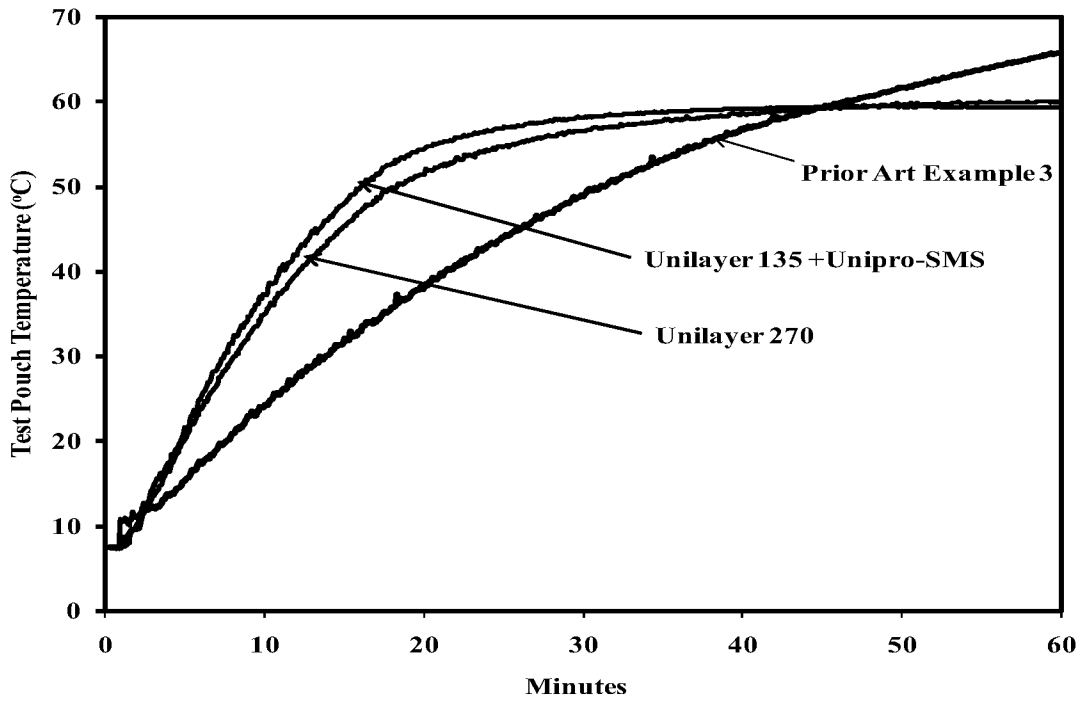

Fig. 7

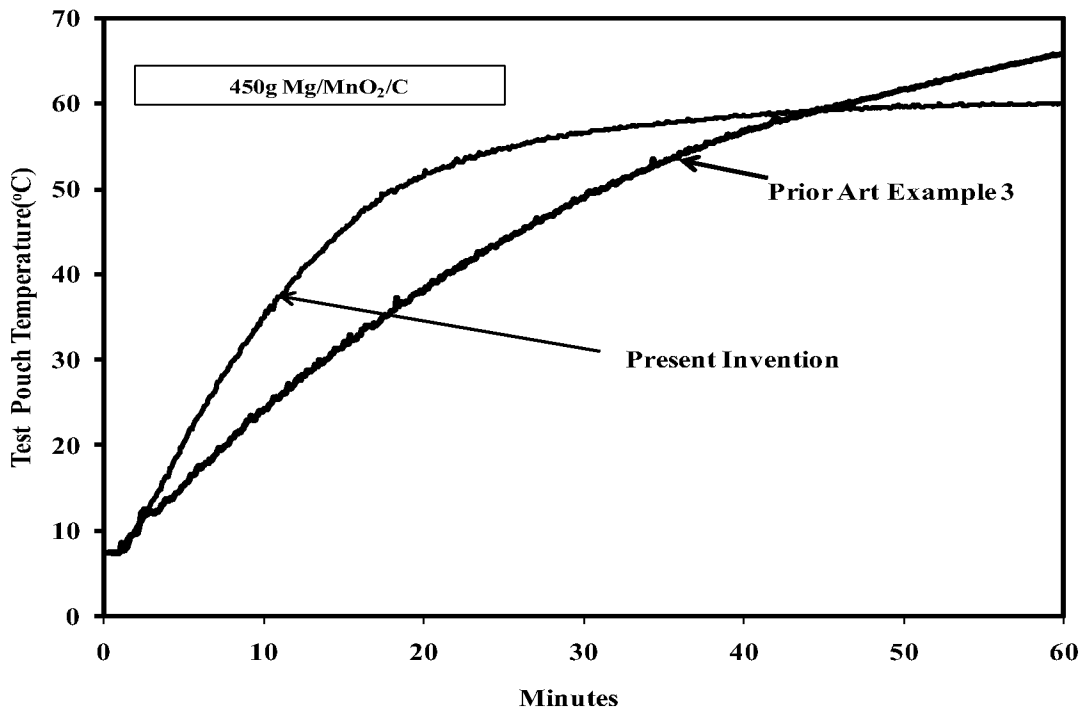

Fig. 8

INTERNATIONAL SEARCH REPORT

International application No.

PCT/US 09/33676

A. CLASSIFICATION OF SUBJECT MATTER

IPC(8) - F24J 1/00; C09K 5/16 (2009.01)

USPC - 149/74; 44/320

According to International Patent Classification (IPC) or to both national classification and IPC

B. FIELDS SEARCHED

Minimum documentation searched (classification system followed by classification symbols)

IPC(8)- F24J 1/00; C09K 5/16 (2009.01)

USPC - 149/74; 44/320

Documentation searched other than minimum documentation to the extent that such documents are included in the fields searched

IPC(8)- F24J 1/00; C09K 5/16 (2009.01)

USPC - 149/74; 44/320

Electronic data base consulted during the international search (name of data base and, where practicable, search terms used)

PubWEST(USPT,PGPB,EPAB,JPAB); Google Patent; Google Scholar. Search Terms: magnesium, hydrogen, eliminate, suppress, absorb, scavenge, introduce, addition, water, aqueous, manganese, ruthenium, transition, metal, oxide, dioxide, overvoltage, suppressor, promoter, flowing, agent, reaction, activator, salt, halide, carbonate,

C. DOCUMENTS CONSIDERED TO BE RELEVANT

Category*	Citation of document, with indication, where appropriate, of the relevant passages	Relevant to claim No.
X	US 2007/0272090 A1 (Bommaraju) 29 November 2007 (29.11.2001) Entire document, especially para [0002], [0010] and [0011].	1-5, 8-15, 22 and 27
Y		6, 7, 16-21, 23-26
Y	US 5,180,718 A (Kump et al.) 19 January 1993 (19.01.1993) Entire document, especially col 20, ln 44	6
Y	US 2006/0154006 A1 (Usui et al.) 13 July 2006 (13.07.2006) Entire document, para [0109], [0110], [0112].	7, 16-21
Y	WO 2007/134295 A1 (Baker et al.) 22 November 2007 (22.11.2007) Entire document , pg 4, para 1 and 2; pg 5 para 1, 3 and 4; pg 6, para 1 and 3; and pg 7, para 4	23-26
Y	US 6,933,333 B2 (Clulow et al.) 23 August 2005 (23.08.2005) col 3, ln 9-11	18
Y	US 6,063,463 A (Schlueter, Jr. et al.) 16 May 2000 (16.05.2000) Entire document, especially col 6, ln 8	20

 Further documents are listed in the continuation of Box C.

* Special categories of cited documents:

"A" document defining the general state of the art which is not considered to be of particular relevance

"E" earlier application or patent but published on or after the international filing date

"L" document which may throw doubts on priority claim(s) or which is cited to establish the publication date of another citation or other special reason (as specified)

"O" document referring to an oral disclosure, use, exhibition or other means

"P" document published prior to the international filing date but later than the priority date claimed

"T" later document published after the international filing date or priority date and not in conflict with the application but cited to understand the principle or theory underlying the invention

"X" document of particular relevance; the claimed invention cannot be considered novel or cannot be considered to involve an inventive step when the document is taken alone

"Y" document of particular relevance; the claimed invention cannot be considered to involve an inventive step when the document is combined with one or more other such documents, such combination being obvious to a person skilled in the art

"&" document member of the same patent family

Date of the actual completion of the international search

19 March 2009 (19.03.2009)

Date of mailing of the international search report

26 MAR 2009

Name and mailing address of the ISA/US

Mail Stop PCT, Attn: ISA/US, Commissioner for Patents
P.O. Box 1450, Alexandria, Virginia 22313-1450

Facsimile No. 571-273-3201

Authorized officer:

Lee W. Young

PCT Helpdesk: 571-272-4300
PCT OSP: 571-272-7774