

(19) World Intellectual Property Organization  
International Bureau



(43) International Publication Date  
3 January 2008 (03.01.2008)

PCT

(10) International Publication Number  
**WO 2008/002405 A2**

(51) International Patent Classification: **Not classified**

(21) International Application Number:  
PCT/US2007/014113

(22) International Filing Date: 15 June 2007 (15.06.2007)

(25) Filing Language: English

(26) Publication Language: English

(30) Priority Data:  
60/814,384 16 June 2006 (16.06.2006) US

(71) Applicant (for all designated States except US): **OPTO CIRCUITS, LTD.** [US/US]; 3848 Del Amo Blvd., Torrance, CA 90503 (US).

(71) Applicant and

(72) Inventor: **DIETIKER, Thomas** [US/US]; 3848 Del Amo Blvd., Torrance, CA 90503 (US).

(74) Agent: **FACTOR, Jody, L.**; Factor & Lake, LTD., 1327 W. Washington Blvd., Suite 5G/H, Chicago, IL 60607 (US).

(81) Designated States (unless otherwise indicated, for every kind of national protection available): AE, AG, AL, AM,

AT, AU, AZ, BA, BB, BG, BH, BR, BW, BY, BZ, CA, CH, CN, CO, CR, CU, CZ, DE, DK, DM, DO, DZ, EC, EE, EG, ES, FI, GB, GD, GE, GH, GM, GT, HN, HR, HU, ID, IL, IN, IS, JP, KE, KG, KM, KN, KP, KR, KZ, LA, LC, LK, LR, LS, LT, LU, LY, MA, MD, ME, MG, MK, MN, MW, MX, MY, MZ, NA, NG, NI, NO, NZ, OM, PG, PH, PL, PT, RO, RS, RU, SC, SD, SE, SG, SK, SL, SM, SV, SY, TJ, TM, TN, TR, TT, TZ, UA, UG, US, UZ, VC, VN, ZA, ZM, ZW.

(84) Designated States (unless otherwise indicated, for every kind of regional protection available): ARIPO (BW, GH, GM, KE, LS, MW, MZ, NA, SD, SL, SZ, TZ, UG, ZM, ZW), Eurasian (AM, AZ, BY, KG, KZ, MD, RU, TJ, TM), European (AT, BE, BG, CH, CY, CZ, DE, DK, EE, ES, FI, FR, GB, GR, HU, IE, IS, IT, LT, LU, LV, MC, MT, NL, PL, PT, RO, SE, SI, SK, TR), OAPI (BF, BJ, CF, CG, CI, CM, GA, GN, GQ, GW, ML, MR, NE, SN, TD, TG).

Published:

— without international search report and to be republished upon receipt of that report

For two-letter codes and other abbreviations, refer to the "Guidance Notes on Codes and Abbreviations" appearing at the beginning of each regular issue of the PCT Gazette.

(54) Title: SYSTEM AND METHOD FOR A NON-INVASIVE MEDICAL SENSOR

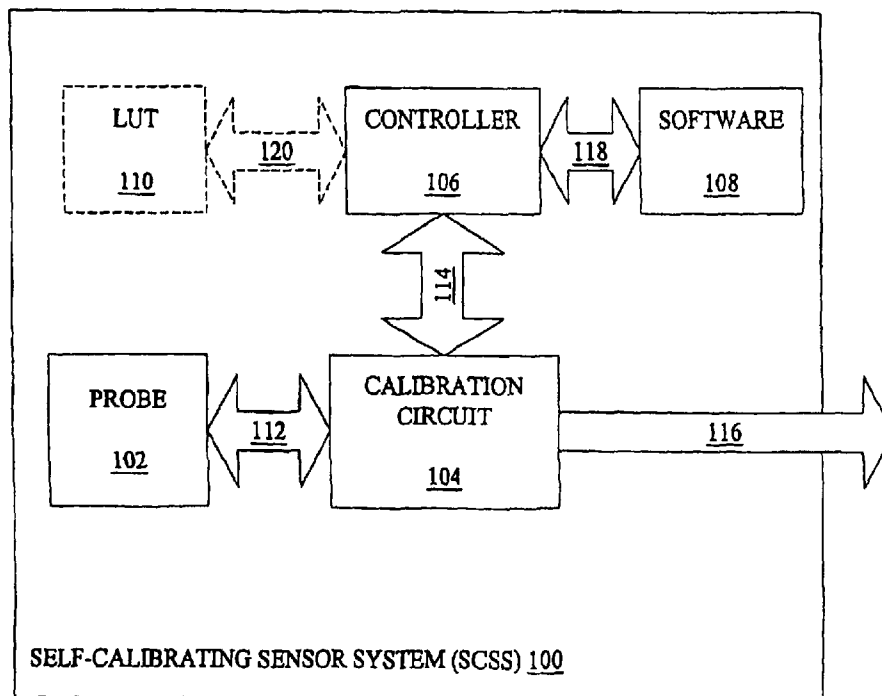

(57) Abstract: A sensor is disclosed having one or more light sources, and one or more light detectors. At least one of the detectors produces an output in response to received light. Also, electrical circuitry in response to the output generates a pulse waveform proportional to the arterial and venous pulse of a human body, wherein the pulse waveform is used to synchronize an arterial-pulse measurement of the absorption or reflectance of one or more coherent light sources.

WO 2008/002405 A2

## **SYSTEM AND METHOD FOR A NON-INVASIVE MEDICAL SENSOR**

### **RELATED APPLICATIONS**

**[Para 1]** This application claims the benefit of U.S. Provisional Patent Application Serial No. 60/814,384, filed on June 16, 2006.

### **FIELD OF THE INVENTION**

**[Para 2]** The present invention relates generally to non-invasive medical sensing devices, and in particular to error correction for a medical sensor.

### **FEDERALLY SPONSORED RESEARCH OR DEVELOPMENT**

**[Para 3]** None.

### **DESCRIPTION OF RELATED ART**

**[Para 4]** Coherent light sources are utilized in a broad range of applications in many distinct fields of technology including the consumer, industrial, medical, defense and scientific fields. In the medical field an emitter-receiver pair of coherent light sources in form of light-emitting diodes (LEDs) or similar devices are often utilized in medical sensing devices to obtain accurate non-invasive measurements. An example application of such a medical sensing device may include a blood constituent monitoring system and/or a non-invasive oximeter that may be utilized to monitor arterial oxygen saturation.

**[Para 5]** In non-invasive oximetry, coherent light having a known specific wavelength is typically transmitted from an emitter LED through a target, such as biological tissue carrying blood, to a photodetector. The photodetector receives and measures a portion of transmitted coherent light that is neither absorbed nor reflected from the blood in the biological tissue in order to determine the oxygen saturation (SP02) within the blood. Similarly, an example of an industrial application may include a non-invasive sensor system having a coherent light of a known specific wavelength transmitted from a coherent light source (such as an LED emitter) through a target, such as a fluid or material, to a photodetector.

**[Para 6]** Unfortunately, these types of non-invasive sensor systems utilizing a coherent light source require accurate prior knowledge of the wavelength of the coherent light source in order to determine the amount of coherent light that is absorbed or reflected through the target. One way of having the prior knowledge of the wavelength is to select coherent light

source emitters that have wavelengths within a certain range of tolerance. As such, attempts at determining the wavelength have included a binning process of selecting LEDs within the required nominal wavelength specifications and/or encoding data corresponding to the wavelength employed in a sensor as part of the sensor by means of a resistor, memory device or similar component.

**[Para 7]** However, it is appreciated by those skilled in the art and familiar with the production of emitter-photodiode sensing devices that there is a need to be able to select from a wider variation of emitter output wavelengths in reducing the production costs and defect rates of the sensing devices. As an example, typical production techniques require selection of an emitter within 2 nm of a target wavelength, which may lead to rejection of 40-60% of the component emitters. Moreover, an additional problem is that a selected emitter, which was within the target wavelength at time of production, will typically degrade over time, vary with temperature, and the drive circuit may become unstable and cause a wavelength shift. Attempts to solve the wavelength shift problem have included systems that correlate the wavelength shift to a change in drive circuit current. The change in drive circuit current drives the LED to a specific wavelength. Typically, these systems include a scheme for determining the wavelength shift of the photodiodes via a series of filters, diffusers and a plurality of photodetectors. Unfortunately, this approach is too complex and expensive for practical manufacturing techniques and cannot be employed in each sensor being used with monitoring devices.

**[Para 8]** Therefore, there is a need for a non-invasive sensor system that is capable of measuring the wavelength of a light source without requiring prior knowledge of the wavelength of the light source and is not complex or expensive to manufacture. Moreover, there is a need for error reduction in such sensor systems.

## **SUMMARY OF THE INVENTION**

**[Para 9]** The present invention is directed to a non-invasive medical sensing device having error correction. According to one aspect of the invention the sensor has one or more light sources and one or more light detectors. At least one of the detectors produces an output in response to the received light. Further, electrical circuitry responsive to the output generates a pulse waveform proportional to the arterial and venous pulse of a human body, wherein the pulse waveform is used to synchronize an arterial-pulse measurement of the absorption or reflectance of one or more coherent light sources.

**[Para 10]** According to another aspect of the invention, a method is provided. The method includes emitting a light, and receiving, as incident light radiation, at least a portion of the light. The method also includes producing an output in response to the incident light radiation received, and generating, in response to the output, a pulse waveform proportional to the arterial and venous pulse of a human body wherein the pulse waveform is used to synchronize an arterial-pulse measurement of the absorption or reflectance of one or more coherent light sources.

**[Para 11]** Other embodiment, systems, methods, features, and advantages of the present invention will be, or will become, apparent to one having ordinary skill in the art upon examination of the following drawings and detailed description. It is intended that all such additional systems, methods, features, and advantages included within this description be within the scope of the present invention, and be protected by the accompanying claims.

#### **BRIEF DESCRIPTION OF THE DRAWINGS**

**[Para 12]** The invention may be better understood with reference to the following figures. The components in the figures are not necessarily to scale, emphasis instead being placed upon clearly illustrating the principles of the invention. Moreover, in the figures, like reference numerals designate corresponding parts throughout the several views:

**[Para 13]** FIGURE 1 illustrates a block diagram of an example implementation of a self-calibrating sensor system (SCSS);

**[Para 14]** FIGURE 2 illustrates a block diagram of an example implementation of the probe block of the SCSS shown FIGURE 1;

**[Para 15]** FIGURE 3 illustrates a cross-sectional view of an example implementation of the probe shown in FIGURE 2;

**[Para 16]** FIGURE 4A illustrates a cross-sectional view of another example implementation of the probe shown in FIGURE 2;

**[Para 17]** FIGURE 4B illustrates a cross-sectional view of example reflective implementation of the probe shown in FIGURE 2;

**[Para 18]** FIGURE 5 is a top view of an example implementation of the probe shown in FIGURE 4;

**[Para 19]** FIGURE 6 is a cross-sectional view of the probe implementation of FIGURE 5;

**[Para 20]** FIGURE 7 illustrates an example implementation of the probe block shown in FIGURE 2 utilizing photodiodes;

**[Para 21]** FIGURE 8 illustrates a cross-sectional view of an example implementation of the wavelength sensor block shown in FIGURE 7 utilizing a double diffusion photodiode; .

**[Para 22]** FIGURE 9 is a graph of the response curve of the wavelength sensor shown in FIGURE 8;

**[Para 23]** FIGURE 10 is schematic diagram depicting an exemplary implementation of the calibration circuit block shown in FIGURE 1;

**[Para 24]** FIGURE 11 is schematic diagram depicting another exemplary implementation of the calibration circuit block shown in FIGURE 1;

**[Para 25]** FIGURE 12 is a flow chart illustrating the process performed by the SCSS shown in FIGURE 1;

**[Para 26]** FIGURE 13 is a simplified cross-sectional view of a sensor in accordance with the present invention;

**[Para 27]** FIGURE 14 is a chart depicting the typical spectral absorption characteristics of an arterial and venous pulse;

**[Para 28]** FIGURE 15 is a chart depicting response of the wavelength sensor to both arterial and venous pulses;

**[Para 29]** FIGURE 16 is a simplified block diagram of a processing system for use with the sensor of FIGURE 13; and,

**[Para 30]** FIGURE 17 is a chart depicting a pulse waveform proportional to the arterial and venous pulse of the human body as produced after processing the signals from the wavelength sensor.

## **DESCRIPTION OF PREFERRED EMBODIMENTS**

**[Para 31]** The following descriptions of detailed embodiments are for exemplifying the principles and advantages of the inventions claimed herein. They are not to be taken in any way as limitations on the scope of the inventions.

**[Para 32]** FIGURE 1 illustrates a block diagram of a self-calibrating sensor system (SCSS) 100. The SCSS 100 may include a probe 102, a calibration circuit 104, a controller 106, software 108 located on in memory (not shown) and optional lookup table ("LUT") 110. The probe 102 is in signal communication, via signal path 112, to the calibration circuit 104. The calibration circuit 106 may be a divider and/or comparator circuit.

**[Para 33]** The calibration circuit 104 is in signal communication to the controller 106 and an external output device (not shown) via signal paths 114 and 116, respectively. The

controller 106 is in signal communication to software 108 and optional LUT 110 via signal paths 118 and 120, respectively.

**[Para 34]** The controller 106 may be any general-purpose processor such as an Intel XXX86, Motorola 68XXX or PowerPC, DEC Alpha or other equivalent processor.

Alternatively, a specific circuit or oriented device may selectively be utilized as the controller 106. Additionally, the controller 106 may also be integrated into a signal semiconductor chip such as an Application Specific Integrated Chip (ASIC) or Reduced Instruction Set Computer (RISC), or may be implemented via a Digital Signal Processor (DSP) chip. Examples of a specific circuit or oriented device for the controller 106 may also be a mixed sionac ASIC.

**[Para 35]** The software 108 may be resident in memory (not shown) located either internally or externally to the controller 106. The software 108 includes both logic enabling the controller 106 to operate and also logic for self-calibrating the SCSS 100.

**[Para 36]** An example of the external output device may be an oximeter such as a NPB40 manufactured by Nellcor of Pleasanton, Calif., a 9840 Series pulse oximeter manufactured by Nonin Medical, Inc. of Plymouth, Minn., or an equivalent device.

**[Para 37]** FIGURE 2 shows an example implementation of probe 102. Probe 102 may include a probe light source 200 and wavelength sensor 202. Probe light source 200 may include a first light source 204 and second light source 206. First light source 204 and second light source 206 may be implemented utilizing light-emitting diodes (LEDs). As an example implementation in oximeter application, first light source 204 may be an LED emitting light radiation at a wavelength of approximately 660 nm and second light source 206 may be an LED emitting light radiation at a wavelength of approximately 880 nm. Wavelength sensor 202 may be implemented utilizing a double diffusion photodiode. It is appreciated by those of skill in the art that probe light source 200 may also include multiple light sources in the order of three or more.

**[Para 38]** In FIGURE 3, a cross-sectional view of an example implementation of the probe 300 is shown. In this example, probe 300 may be a medical device such as a transmissive blood oxygen saturation and pulse rate sensor. However, it would be appreciated by one skilled in the art that probe 300 may also be a reflective sensor. Additionally, probe 300 may also be utilized for measuring other blood constituents including, but not limited to, oxyhemoglobin, bilirubin, carboxy-hemoglobin, and glucose. Probe 300 may include a rigid casing 302 having a cavity 304 and casing butt 306, first light source 204, second light source 206 and wavelength sensor 202. Probe 300 is connected to calibration circuit 104, FIGURE

1, via signal path 112. A material 308, FIGURE 3, such as a finger may be inserted into the cavity 304.

**[Para 39]** As an example, first light source 204 and second light source 206 may be two LED emitters that produce light radiation at a wavelength of approximately 660 nm and 880 nm, respectively. Wavelength sensor 202 is supported within the rigid casing 302 opposite first light source 204 and second light source 206. First light source 204 and second light source 206 and wavelength sensor 202 may be in signal communication with a control cable (not shown). The control cable is in signal communication with an oximeter (not shown) via signal path 112. The oximeter determines the oxygen saturation of the blood in the material 308 (in this example a finger) by measuring and processing the amount of incident light radiation reaching wavelength sensor 202 from a pulse of light radiation from first light source 204.

**[Para 40]** In operation, the SCSS 100, FIGURE 1, performs a self-calibration procedure prior to and while measuring any of the properties of the material 308, FIGURE 3. This self-calibration procedure includes emitting a pulse of light radiation from the first light source 204 that is received as incident light radiation by wavelength sensor 202 prior to inserting material 308 into the cavity 304. The oximeter utilizes the measured incident light radiation received by wavelength sensor 202 to determine the operating wavelength of the first light source 204. Once the operating wavelength of the first light source 203 is known, the SCSS 100, FIGURE 1, is utilized in combination with the oximeter to accurately determine blood oxygen saturation of the material 308.

**[Para 41]** The continuous self-calibration procedure is beneficial because it is appreciated by those skilled in the art that light radiation output by first light source 204 of 660 nm in this example implementation is in the red spectral region. It is the absorption of this red light radiation that the oximeter utilizes to determine the oxygen saturation of the blood. As such, a relatively small variation in operating wavelength may results in inaccurate readings at the oximeter. As an example, without the self-calibration procedure, if the light radiation output by first light source 204 varied in excess of  $\pm 2$  nm from an operating wavelength required by the oximeter, the results would be inaccurate.

**[Para 42]** FIGURE 4A illustrates a cross-sectional view of another example implementation of probe 400. In this example, probe 400 may include a rigid or flexible casing 402 having a cavity 404, first light source 204, second light source 206 and wavelength sensor 202. Similar to the previous example implementation, probe 400 is

connected to calibration circuit 104, FIGURE 1, via signal path 112, however, probe 400, FIGURE 4A, does not have a cavity butt. A material 406 may be inserted into the cavity 404.

**[Para 43]** Similar to the previous example, first light source 204 and second light source 206 may be two LED emitters that produce light radiation at different wavelengths.

Wavelength sensor 202 is supported within the rigid casing 402 opposite first light source 204 and second light source 206. First light source 204 and second light source 206 and wavelength sensor 202 may be in signal communication with a control cable (not shown).

The control cable is in signal communication with a measuring device (not shown) via signal path 112. The measuring device determines the properties in the material 406 by measuring and processing the amount of incident light radiation reaching wavelength sensor 202 from a pulse of light radiation from first light source 204.

**[Para 44]** As an industrial example, the material 406 may be a fluid, liquid or solid material that exhibits optical transmissive characteristics that may be measured and utilized to determine the properties of the material. An example implementation would include measuring the properties of the material for process or quality control purposes.

**[Para 45]** Again in operation, the SCSS 100, FIGURE 1, performs a self-calibration procedure prior to measuring any of the properties of the material 406, FIGURE 4A. This self-calibration procedure includes emitting a pulse of light radiation from the first light source 204 that is received as incident light radiation by wavelength sensor 202 prior to inserting material 406 into the cavity 404. The measuring device utilizes the measured incident light radiation received by wavelength sensor 202 to determine the operating wavelength of the first light source 204. Once the operating wavelength of the first light source 204 is known, the SCSS 100, FIGURE 1, is utilized in combination with the measuring device to accurately determine the properties of the material 406.

**[Para 46]** FIGURE 4B illustrates a cross-sectional view of an example reflective implementation of probe 408. In this example, probe 408 may include a rigid or flexible casing 410 having a cavity 412, first light source 204, second light source 206 and wavelength sensor 202. Similar to the previous example implementation, probe 408 is connected to calibration circuit 104, FIGURE 1, via signal path 112, however, probe 408, FIGURE 4B, does not have a cavity butt. A material 412 may be inserted into the cavity 412.

**[Para 47]** Similar to the previous example, first light source 204 and second light source 206 may be two LED emitters that produce light radiation at different wavelengths. However, in this example, wavelength sensor 202 is supported within the rigid casing 410 adjacent to first light source 204 and second light source 206. First light source 204 and second light

source 206 and wavelength sensor 202 may be in signal communication with a control cable (not shown). The control cable is in signal communication with a measuring device (not shown) via signal path 112. The measuring device determines the properties in the material 412 by measuring and processing the amount of incident light radiation reflected by material 412 and reaching wavelength sensor 202 from a pulse of light radiation from first light source 204.

**[Para 48]** Again, as an industrial example, the material 412 may be a fluid, liquid or solid material that exhibits optical transmissive characteristics that may be measured and utilized to determine the properties of the material. An example implementation would include measuring the properties of the material for process or quality control purposes.

**[Para 49]** Again in operation, the SCSS 100, FIGURE 1, performs a self-calibration procedure prior to measuring any of the properties of the material 412, FIGURE 4B. This self-calibration procedure includes emitting a pulse of light radiation from the first light source 204 that is reflected by flexible casing 410 and later received as incident light radiation by wavelength sensor 202 prior to inserting material 412 into the cavity 410. The measuring device utilizes the measured incident light radiation received by wavelength sensor 202 to determine the operating wavelength of the first light source 204. Once the operating wavelength of the first light source 204 is known, the SCSS 100, FIGURE 1, is utilized in combination with the measuring device to accurately determine the properties of the material 412.

**[Para 50]** It is appreciated by of skill in the art that it is possible to generate signals from the wavelength sensor 202, FIGURE 2 during operation of the light sources 204 and 206 through the medium (i.e., material 308, FIGURE 3, 406, FIGURE 4A, and/or 414, FIGURE 4B) being inspected. It is also possible to generate the same signals using light reflected off the medium. Therefore, it is not necessary to couple the light sources 204, FIGURE 2 and 206 directly to the wavelength sensor 202 as long as the medium either transmits or reflects enough light to generate processable signals from the wavelength sensor 202.

**[Para 51]** In FIGURE 5, a top view of an example medical implementation of probe 500 having a flexible casing (i.e., flexible strip) 502 is shown. Probe 500 may include first light source 204, second light source 206 and wavelength sensor 202. In this example implementation, probe 500 is a blood oxygen saturation and pulse rate sensor that utilizes the flexible strip 502 to attach to a material, such as a body part (not shown). The probe 500 is connected to an oximeter (not shown) via signal path 112. The flexible strip 502 may be wrapped around the body part and affixed to itself via an attachment strip (such as an

adhesive strip) 504. Example body parts would include a finger, toe, ear-lobe, arm, leg or other similar parts.

**[Para 52]** As an example, first light source 204 and second light source 206 may be two LED emitters that produce light radiation at a wavelength of approximately 660 nm and 880 nm, respectively. Wavelength sensor 202 is supported within the flexible strip 502 and placed opposite first light source 204 and second light source 206 when the flexible strip 502 is wrapped around a body part. First light source 204 and second light source 206 and wavelength sensor 202 may be in signal communication with a control cable (not shown). The control cable is in signal communication with an oximeter (not shown) via signal path 112. The oximeter determines the oxygen saturation of the blood in the body part by measuring and processing the amount of incident light radiation reaching wavelength sensor 202 from a pulse of light radiation from first light source 204.

**[Para 53]** As before, in operation, the SCSS 100, FIGURE 1, performs a self-calibration procedure prior to measuring any of the properties of the body part. This self-calibration procedure includes, prior to wrapping flexible strip 502 around the body part, bending the flexible strip 502 so that the first light source 204 and second light source 206 are opposite in special orientation to wavelength sensor 202 and then emitting a pulse of light radiation from the first light source 204 that is received as incident light radiation by wavelength sensor 202. The oximeter utilizes the measured incident light radiation received by wavelength sensor 202 to determine the operating wavelength of the first light source 204. Once the operating wavelength of the first light source 204 is known, placed around a body part and the wavelength sensor 202 measures the incident light radiation emitted by the first light source 204 and passing through the blood flowing within the body part. The SCSS 100, FIGURE 1, is then utilized in combination with the oximeter to accurately determine blood oxygen saturation of the body part. In FIGURE 6, a cross-sectional view of the probe 500 is shown in a wrap type position.

**[Para 54]** In FIGURE 7, an example implementation of the probe 700 is shown utilizing photodiodes. Similar to FIGURE 2, Probe 700, FIGURE 7, includes probe light source 702 and wavelength sensor 704. Probe light source 702 includes first light source 706 and second light source 708. First light source 706 may include LED 710 and second light source may include LED 712. Wavelength sensor 704 is a double diffusion photodiode.

**[Para 55]** As an example of operation, LED 710 and LED 712 may have their cathodes grounded in common at signal path 714 and may emit light radiation 716 at wavelengths 660 nm and 880 nm, respectively, when a voltage is applied at anodes 718 and 720, respectively.

The emitted light radiation 716 is incident on material 722. A part of the emitted light radiation 716 is transmitted through material 722 and is received as incident light radiation 724 by wavelength sensor 704. As before, in order to properly measure the properties of the material 722 from the received incident light radiation 724, the SCSS 100, FIGURE 1 performs a self-calibration procedure.

**[Para 56]** The SCSS 100, FIGURE 1, performs a self-calibration procedure prior to measuring any of the properties of the material 722. This self-calibration procedure includes emitting a pulse of light radiation 716 from LED 710 that is received as incident light radiation 724 by wavelength sensor 704 prior to inserting material 722 between the probe light source 702 and wavelength sensor 704. The oximeter utilizes the measured incident light radiation 724 received by wavelength sensor 704 to determine the operating wavelength of LED 710. Once the operating wavelength of LED 710 is known, the SCSS 100, FIGURE 1, is utilized in combination with the oximeter to accurately determine blood oxygen saturation of the material 722.

**[Para 57]** FIGURE 8 illustrates a cross-sectional view of the wavelength sensor 704 receiving incident light radiation 724 utilizing a double diffusion photodiode (also known as a double junction photodiode). Photodiodes with double diffusion are typically utilized to accurately measure the centroid wavelength of light sources such as LEDs 710 and 712. Double diffusion photodiodes are processed with two junctions, one on the top surface and one on the back surface of a semiconductor photodiode (such as a Si-photodiode), each junction typically exhibits a different and well-defined spectral response. As result, by measuring the quotient of signals generated by the two junctions, the centroid wavelength of any given monochromatic light source may be determined.

**[Para 58]** The wavelength sensor 704 has two p-n junctions constructed vertically on a common silicon substrate. The wavelength sensor 704 includes a first anode 800, common cathode 802, first diode 804 (also known as an upper diode), second diode 806 (also known as a lower diode), second anode 808, and a thin active region 810. The first anode 800 is positioned on the top surface above the common cathode 802 forming the first diode 804. The thickness of the first diode 804 is chosen so that the energy of the shortest wavelength being measured from the incident light radiation 724 is absorbed entirely therein. The second diode 806 is formed between the common cathode 802 and the second anode 808 that placed on the bottom surface with the thin active region 810 between the common cathode 802 and the second anode 808. The thickness of the thin active region 810 is selected to allow for

absorption of substantially all of the longest measured wavelength of incident light radiation 724.

**[Para 59]** FIGURE 9 illustrates a typical plot 900 of the spectral response of the wavelength sensor 704, FIGURE 8. The plot 900, FIGURE 9, has a vertical axis 902 representing relative response, in percentage, of the wavelength sensor 704, FIGURE 8, and a horizontal axis 904, FIGURE 9, representing the wavelength of the incident light radiation 724, FIGURE 8. The plot 900, FIGURE 9, shows two response curves 906 and 908 representing the relative response versus wavelength for the first diode 804, FIGURE 8, and the second diode 806, respectively.

**[Para 60]** As an example of operation of the wavelength sensor 704, the first diode 804 may have an enhanced blue response and the second diode 806 may have an enhanced red response. In this example, the absorbed radiation of the incident light radiation 724 between the red and blue responses (such as between 450 and 900 nm) generates two photocurrent signals proportional to the wavelength of the incident light radiation 724. The quotient of these photocurrent signals is independent of the light level up to the saturation point of the wavelength sensor 704. Utilizing this example, the wavelength of either monochromatic incident light radiation 724 or the spectral density peak of polychromatic incident light radiation 724 may be determined. An example of the wavelength sensor 704 may be a PSS WS-7.56 wavelength sensor produced by Pacific Silicon Sensor, Inc. of Westlake Village, Calif.

**[Para 61]** In FIGURE 10, a schematic diagram depicting an exemplary implementation of the calibration circuit 1000 is shown. The calibration circuit 1000 is in signal communication with the probe 1002 and controller 106, FIGURE 1, via signal paths 112 and 114, respectively. The calibration circuit 1000 may include a pair of amplifiers 1004 and 1006 (such as log amplifiers) in signal communication with first anode 800, FIGURE 8 and second anode 808 of wavelength sensor 1008, FIGURE 10, and a differential amplifier 1010, via signal paths 1010, 1012 and 1014, respectively. The differential amplifier 1008 is in signal communication with the controller 106, FIGURE 1, via signal path 112.

**[Para 62]** In operation, the wavelength sensor 1004 produces two photocurrent signals from the two junctions (i.e., photodiodes 804 and 806) in the double diffusion photodiode. Each junction in the wavelength sensor 1004 exhibits a different and well-defined spectral response, which is known to the controller 106, FIGURE 1, and the magnitude of these two resulting photocurrent signals are proportional to the wavelength of the measured incident light radiation 724, which corresponds to one of the light sources (either 204 or 206, FIG. 2)

in probe 1002, FIGURE 10. The photocurrent signals are amplified by amplifiers 1004 and 1006 via signal paths 1010 and 1012, respectively, and input into the differential amplifier 1008 via signal path 1018 and 1020. If the amplified photocurrent signals 1018 and 1020 are approximately equal the corresponding differential output signal 1022 of the differential amplifier 1008 is almost equal to zero. Once the differential output signal 1022 is almost equal to zero the wavelength of the incident light radiation is determined and the SCSS 100, FIGURE 1, is calibrated.

**[Para 63]** When the amplified photocurrent signals 1018 and 1020 are not approximately equal the corresponding differential output signal 1022 will vary according to the difference in magnitude value between the amplified photocurrent signals 1018 and 1020. The differential output signal 1022 is utilized as a reference by the controller 106, FIGURE 1. The controller 106 determines the wavelength of the incident light radiation 724 by knowing the spectral response of the photodiodes 804 and 806, FIGURE 8. The controller 106 either determines the wavelength of the incident light radiation 724 utilizing software 108 or other hardware (not shown) located in the SCSS 100. The software 108 may include logic that allows the controller 106 to calculate the wavelength values in real-time from the measure values received from the wavelength sensor 1004.

**[Para 64]** Alternatively, the controller 106 may determine the wavelength of the incident light radiation 724 utilizing the lookup ("LUT") table 110. The LUT 110 may be resident in memory (not shown) resident either internally or externally to the controller 106. The LUT 110 includes a tabulation of known spectral response in voltage versus wavelength for each photodiode 804 and 806, FIGURE 8. Once the controller 106 measures the differential output signal 1022, FIGURE 10, the software 108, FIGURE 1, compares the value of the differential output signal 1022, FIGURE 10, against values stored in the LUT 110, FIGURE 1, and then retrieves a corresponding wavelength value. The controller 106 then utilizes the retrieved wavelength wave to self-calibrate the SCSS 100.

**[Para 65]** Besides self-calibration, the SCSS 100 is also capable of temperature compensating for variation in the wavelength of the incident light radiation 724 due to temperature variations. The SCSS 100 may compensate for temperature variations by the same process utilized to self-calibrate.

**[Para 66]** FIGURE 11 is another exemplary implementation of the SCSS 100, FIGURE 1, with the calibration circuit 1100, FIG. 1, in an oximeter device 1102. The oximeter device 1102 is in signal communication with probe 1104, via signal path 112, and includes calibration circuit 1100, controller 1106, first driver 1108 and second driver 1110. The probe

1104 includes wavelength sensor 1112 and probe light source 1114 having first light source 1116 and second light source 1118.

**[Para 67]** In operation, the first driver 1108 drives the first light source 1116 and the second driver 1110 drives the second light source 1118. First light source 1116 and the second light source 1118 may individually produce light radiation which is incident of the wavelength sensor 1112. The wavelength sensor 1112 produces two photocurrent signals from the two junctions (i.e., photodiodes 804 and 806) in the double diffusion photodiode. Again, each junction in the wavelength sensor 1112 exhibits a different and well-defined spectral response, which is know to the controller 1106 and the magnitude of these two resulting photocurrent signals are proportional to the wavelength of the measured incident light radiation, which corresponds to one of the light sources (either 1116 or 1118) in probe 1104. The photocurrent signals 1120 and 1122 processed and input into the differential amplifier 1224. If the photocurrent signals 1120 and 1122 are approximately equal the corresponding differential output signal 1126 of the differential amplifier 1124 is almost equal to zero. Once the differential output signal 1126 is almost equal to zero the wavelength of the incident light radiation is determined and the SCSS 100, FIGURE 1, is calibrated.

**[Para 68]** When the photocurrent signals 1120 and 1122 are not approximately equal the corresponding differential output signal 1126 will vary according to the difference in magnitude value between the photocurrent signals 1120 and 1122. The differential output signal 1126 is the utilized as a reference by the controller 1106. The controller 1106 determines the wavelength of the incident light radiation by knowing the spectral response of the photodiodes 804 and 806.

**[Para 69]** The controller 1106 either determines the wavelength of the incident light radiation utilizing software 108, FIGURE 1, or other hardware (not shown) located in the SCSS 100. The software 108 may include logic that allows the controller 1106, FIGURE 11, to calculate the wavelength values in real-time from the measure values received from the wavelength sensor 1112.

**[Para 70]** Alternatively, the controller 1106 may determine the wavelength of the incident light radiation utilizing the lookup LUT 110, FIG. 1. The LUT 110 may be resident in memory (not shown) resident either internally or externally to the controller 1106, FIGURE 11. The LUT 110, FIGURE 1, includes the tabulation of known spectral response in voltage versus wavelength for each photodiode 804 and 806. Once the controller 1106 measures the differential output signal 1126, FIGURE 11, the software 108, FIGURE 1, compares the value of the differential output signal 1126, FIGURE 11, against values stored

in the LUT 110, FIGURE 1, and then retrieves a corresponding wavelength value. The controller 1106, FIGURE 11, then utilizes the retrieved wavelength wave to self-calibrate the SCSS 100, FIGURE 1.

**[Para 71]** FIGURE 12 illustrates the process performed by the SCSS 100, FIGURE 1. The process begins in step 1200, FIGURE 12. In step 1202, the wavelength sensor 202, FIGURE 2, receives incident light radiation 200 from the probe light source 200. Within the wavelength sensor 202, the first diode 804, FIGURE 8, receives short wavelengths from the incident light radiation 200, in step 1204, FIGURE 12, and the second diode 806, FIGURE 8, receives long wavelengths from the incident light radiation 200 in step 1206, FIGURE 12. In step 1208, the first diode 804 produces a first photocurrent signal 1010, FIGURE 10, in response to receiving short wavelengths from the incident light radiation 200 and the second diode 806 produces a second photocurrent signal 1012, FIGURE 10, in response to receiving short wavelengths from the incident light radiation 200 in step 1210, FIGURE 12. Finally, in step 1212, the calibration circuit 104 and/or controller 106, FIGURE 1, determine the wavelength of the incident light radiation 200 by comparing the first photocurrent signal 1010 to the second photocurrent signal 1012. The process then ends in step 1214.

**[Para 72]** The SCSS 100 may be selectively implemented in software, hardware, or a combination of hardware and software. For example, the elements of the SCSS 100 may be implemented in software 108 stored in a memory (not shown) located in a controller 106. The controller 106 may be in signal communication with a DSP or ASIC chip via communication link 112 (which may selectively be a system bus). The software 108 configures and drives the DSP or ASIC chip and performs the steps illustrated in FIGURE 12.

**[Para 73]** The software 108 comprises an ordered listing of executable instructions for implementing logical functions. The software 108 may be embodied in any computer-readable medium for use by or in connection with an instruction execution system, apparatus, or device, such as a computer-based system, processor-containing system, or other system that may selectively fetch the instructions from the instruction execution system, apparatus, or device and execute the instructions. In the context of this document, a "computer-readable medium" is any means that may contain, store, communicate, propagate, or transport the program for use by or in connection with the instruction execution system, apparatus, or device. The computer readable medium may be for example, but not limited to, an electronic, magnetic, optical, electromagnetic, infrared, or semiconductor system, apparatus, device, or propagation medium. More specific examples (a non-exhaustive list) of the computer-readable medium would include the following: an electrical connection (electronic) having

one or more wires, a portable computer diskette (magnetic), a RAM (electronic), a read-only memory (ROM) (electronic), an erasable programmable read-only memory (EPROM or Flash memory) (electronic), an optical fiber (optical), and a portable compact disc read-only memory (CDROM) (optical). Note that the computer-readable medium may even be paper or another suitable medium upon which the program is printed, as the program can be electronically captured, via for instance optical scanning of the paper or other medium, then compiled, interpreted or otherwise processed in a suitable manner if necessary, and then stored in a computer memory.

**[Para 74]** Turning to FIGURE 13, in an embodiment, a non-invasive medical sensor is provided for detecting blood constituents of any kind. For instance, the sensor 1310 can be for detecting oxygen saturation of hemoglobin or other parameters.

**[Para 75]** The sensor 1310 can, but not necessarily, have one or more coherent light sources 1312,1313, one broadband light source 1314 and one or more light detectors 1316. In an embodiment, the light sources and the detectors are mounted oppose to each other as shown in FIGURE 13.

**[Para 76]** In an embodiment, the sensor 1310 is placed on a finger 1318 or other extremity of the human body and shines light from the one or more light sources through the extremity. FIGURE 14 provides a depiction of a typical spectral transmission of both oxygenated (arterial) hbO<sub>2</sub> and deoxygenated (venous) hb haemoglobin molecules (hg). Alternatively, the light is reflected off the skin of a part of the human body, instead of being shined through the extremity.

**[Para 77]** As indicated previously, the sensor 1310 includes a wavelength detector 1316, such as a dual photodiode or any other type which produces an output indicating the centroid wavelength of the received light. FIGURE 15 depicts responsiveness of a dual junction wavelength detector for both hbO<sub>2</sub> (arterial) and hb (venous) blood flow using a broad spectrum light source.

**[Para 78]** The sensor 1310 can further include a light source that emits light of a wide light spectrum from, for instance, 200nm to 2000nm or any portion thereof, such as a white LED or any other broad emission device. The sensor 1310 can be connected to a processing system 1610 (FIGURE 16) that drives the light sources, including the broad emission device, and also receives signals from the photodiodes and the wavelength detector.

**[Para 79]** In an embodiment, the processing system 1610 contains, among other things, computer media 1612, memory 1614, and signal processing circuitry 1616 used to calculate various parameters of the blood stream through comparison of the signals received by the

photodiodes of the sensor 1310. Moreover, the processing system 1610 can be used to illuminate the tissue with light generated from the broad emission light source within the sensor.

**[Para 80]** Moreover, in an embodiment, the wavelength detector 1316 generates a signal proportional to the strongest transmission wavelength of the light emitted from the broad emission light source 1314 after the light either passes through the body part 1318 or is reflected from the skin of a human. Turning to FIGURE 17, a signal derived from the wavelength detector 1316 can be further processed by circuitry and computer processing, via the processing system 1610, to obtain a pulse waveform 1710 proportional to the arterial and venous pulse of the human body.

**[Para 81]** Via the processing system 1610, the time domain and amplitude properties of both arterial and venous pulse can be stored and further used to synchronize an arterial-pulse synchronized measurement of the absorption or reflectance of one or more coherent light-sources 1312,1313 through the body's extremity 1318. These signals can then be used in calculating oxygen saturation, carbon-monoxide concentration, haemoglobin or any other parameter of the blood.

**[Para 82]** In an embodiment, the arterial and venous pulse coinciding wavelength detector signals can be used to eliminate or reduce false pulses commonly caused by motion of the human body or extremity, commonly labeled motion artifact, that could cause erroneous measurements.

**[Para 83]** While various implementations of the application have been described, it will be apparent to those of ordinary skill in the art that many more embodiments and implementations are possible that are within the scope of the invention. Accordingly, the invention is not to be restricted except in light of the attached claims and their equivalents.

**WHAT IS CLAIMED IS:**

1. An apparatus comprising: a sensor having one or more coherent light sources, one broadband light source and one or more wavelength detectors wherein the sensors and detectors are mounted opposite each other, and at least one of the detectors produces an output indicating the centroid wavelength of received light.
2. The apparatus of claim 1, wherein the apparatus is placed on a finger or other extremity of the human body and shines light from the one or more light sources through the extremity.
3. The apparatus of claim 1, wherein the sensor reflects light off skin from any part of the human body.
4. The apparatus of claim 1, wherein at least one of the one or more wavelength detectors is a dual photodiode or other type that produces the output indicating a centroid wavelength of received light.
5. The apparatus of claim 1, wherein at least one of the one or more light sources emits light of a wide light spectrum from 200nm to 2000nm or any portion thereof.
6. The apparatus of claim 5, wherein the least one of the one or more light sources emits light of a wide light spectrum is a white LED or any other broad emission device.
7. The apparatus of claim 1, wherein the sensor is connected to a processing system that drives the light sources, including the broad emission device and also receives signals from photodiodes and the wavelength detector.
8. The apparatus of claim 7, wherein the processing system includes computer media, memory, and signal processing circuitry to calculate various parameters of a blood stream through comparison of the signals received by the photodiodes.
9. The apparatus of claim 8, wherein the processing system illuminates the tissue with light generated from the broad emission light source.

10. The apparatus of claim 9, wherein the wavelength detector generates a signal proportional to a strongest transmission wavelength of the light emitted from the broad emission light source, after it either passed through a body part or is reflected off of skin of a human.
11. The apparatus of claim 10, wherein the signal derived from the wavelength detector is processed by circuitry and computer processing to obtain a pulse waveform proportional to the arterial and venous pulse of the human body.
12. The apparatus of claim 11, wherein the time domain and amplitude properties of both the arterial and venous pulse are stored and further used to synchronize an arterial-pulse synchronized measurement of the absorption or reflectance of the one or more coherent light-sources through a portion of the human body.
13. The apparatus of claim 12, wherein the arterial and venous pulse are used to calculate oxygen-saturation, carbon-monoxide concentration or any other parameter of the blood.
14. The apparatus of claim 13, wherein the arterial and venous pulse coinciding wavelength detector signals are used to reduce or eliminate false pulses commonly caused by motion of the portion of the human body.
15. A method comprising the steps of: emitting light from one or more coherent light sources; emitting light from at least one broadband light source; receiving incident light radiation from at least one of the emitted lights; and, producing an output indicating the centroid wavelength of the received incident light radiation.
16. The method of claim 15 further comprising the step of shining the emitted light through at least a portion of a human body.
17. The method of claim 15 further comprising the step of reflecting the emitted light off skin from a portion of a human body.

18. The method of claim 15 wherein the step of emitting light from coherent light sources includes the step of generating light in a wide light spectrum from 200nm to 2000nm or any portion thereof.

19. The method of claim 15 wherein the step of emitting light from the broadband includes the step of generating light from a white LED or any other broad emission device.

20. The method of claim 15 further comprising the step of generating a signal proportional to a strongest transmission wavelength of the light emitted from the broad emission light source, after it either passed through a body part or is reflected off of skin of a human.

21. The method of claim 20 further comprising the step of processing the signal derived from the wavelength detector to obtain a pulse waveform proportional to the arterial and venous pulse of the human body.

22. The method of claim 21 further comprising the steps of storing the time domain and amplitude properties of both the arterial and venous pulse and synchronizing, by using the stored properties, an arterial-pulse synchronized measurement of the absorption or reflectance of the one or more coherent light-sources through a portion of the human body.

23. The method of claim 22 further comprising the steps of calculating oxygen-saturation, carbon-monoxide concentration or any other parameter of the blood by using the arterial and venous pulse.

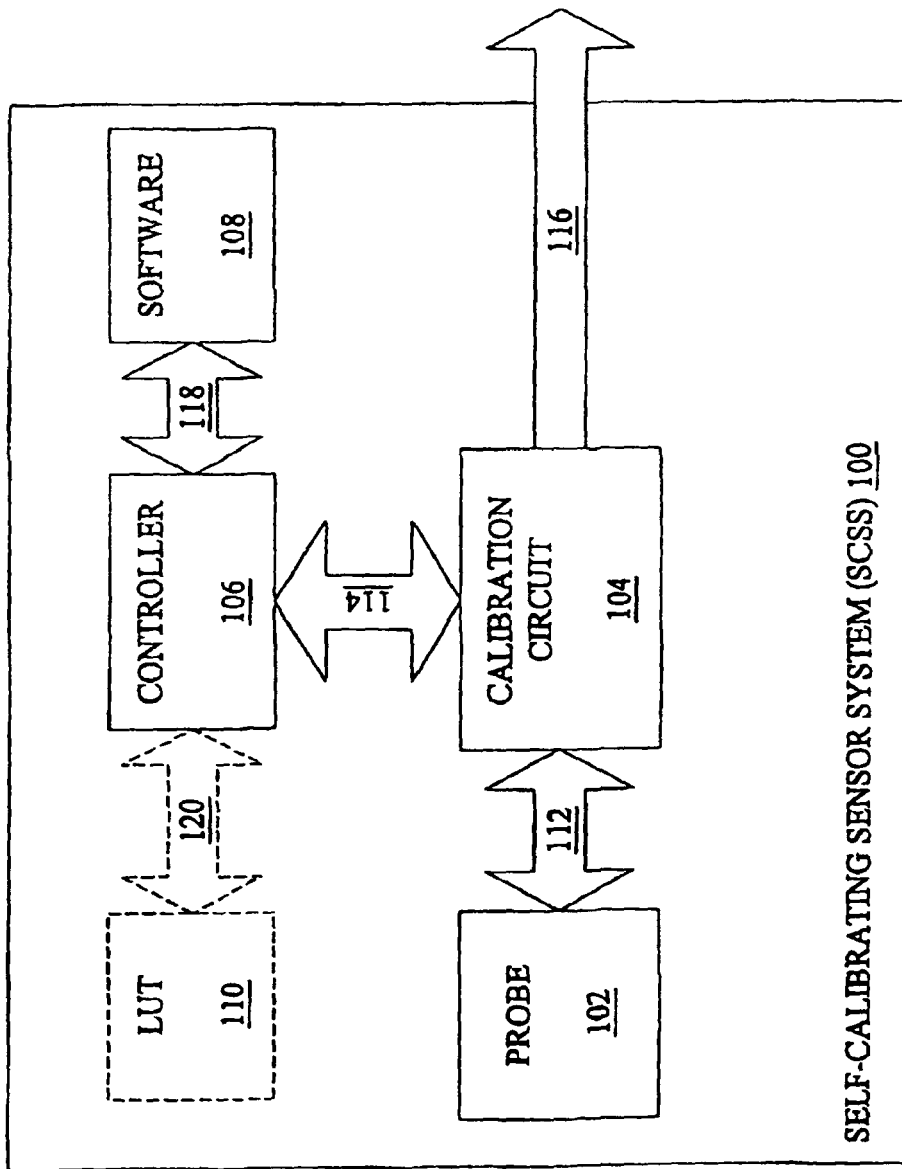

FIG. 1

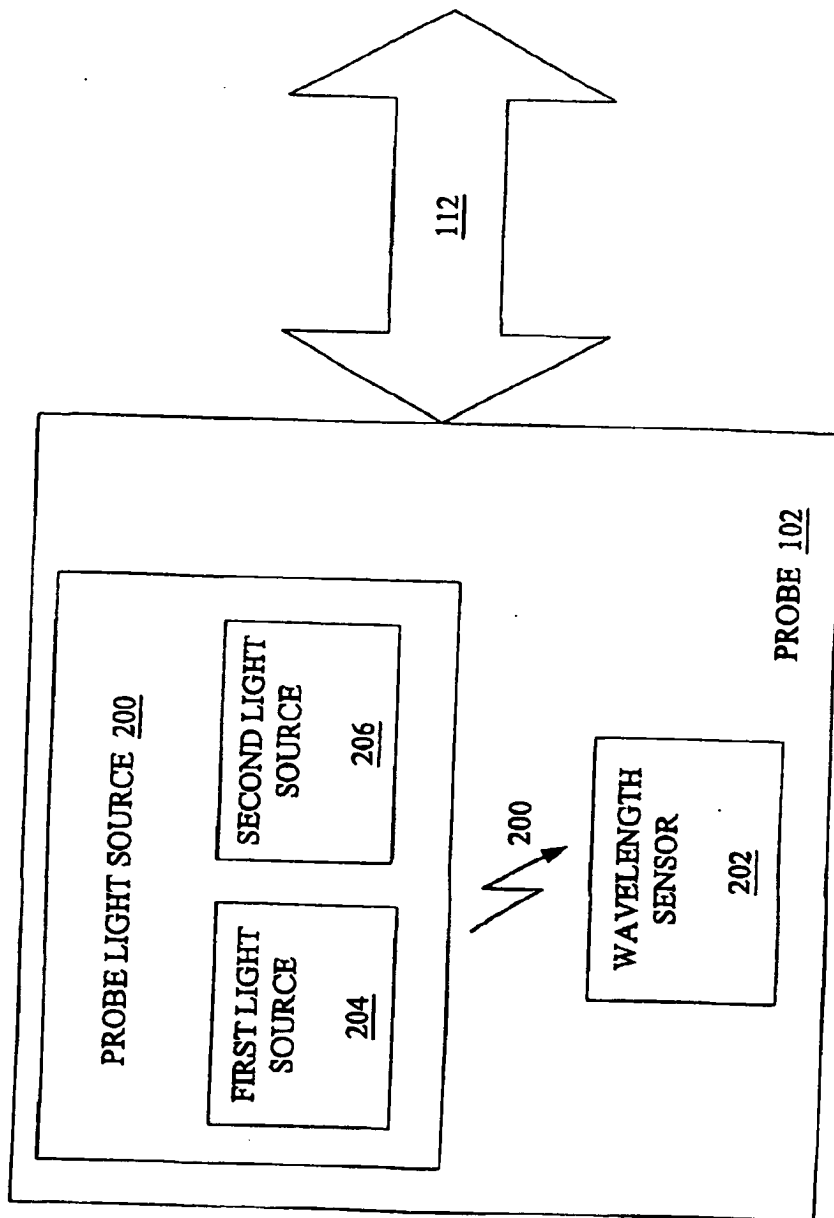

FIG. 2

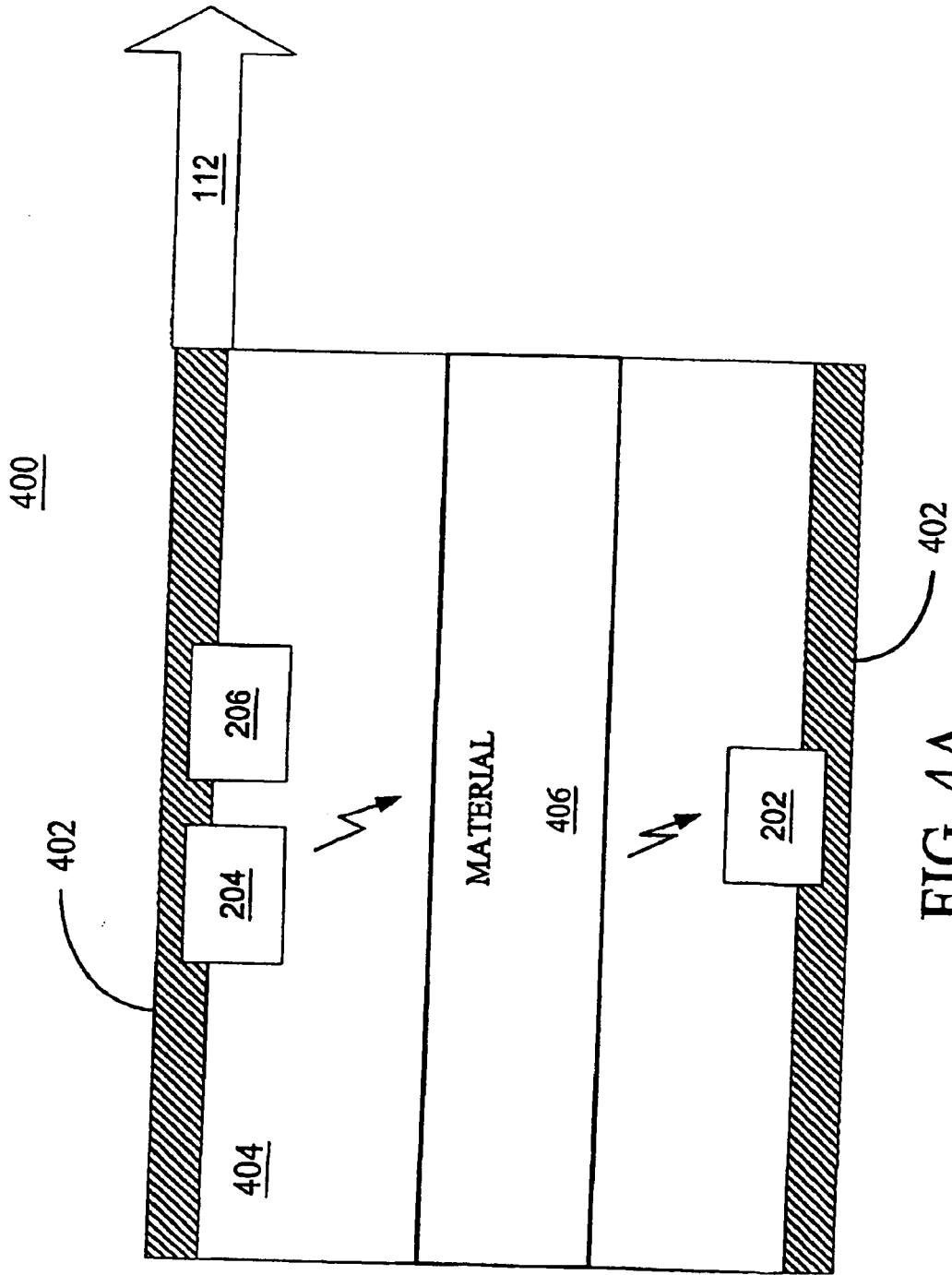

FIG. 4A

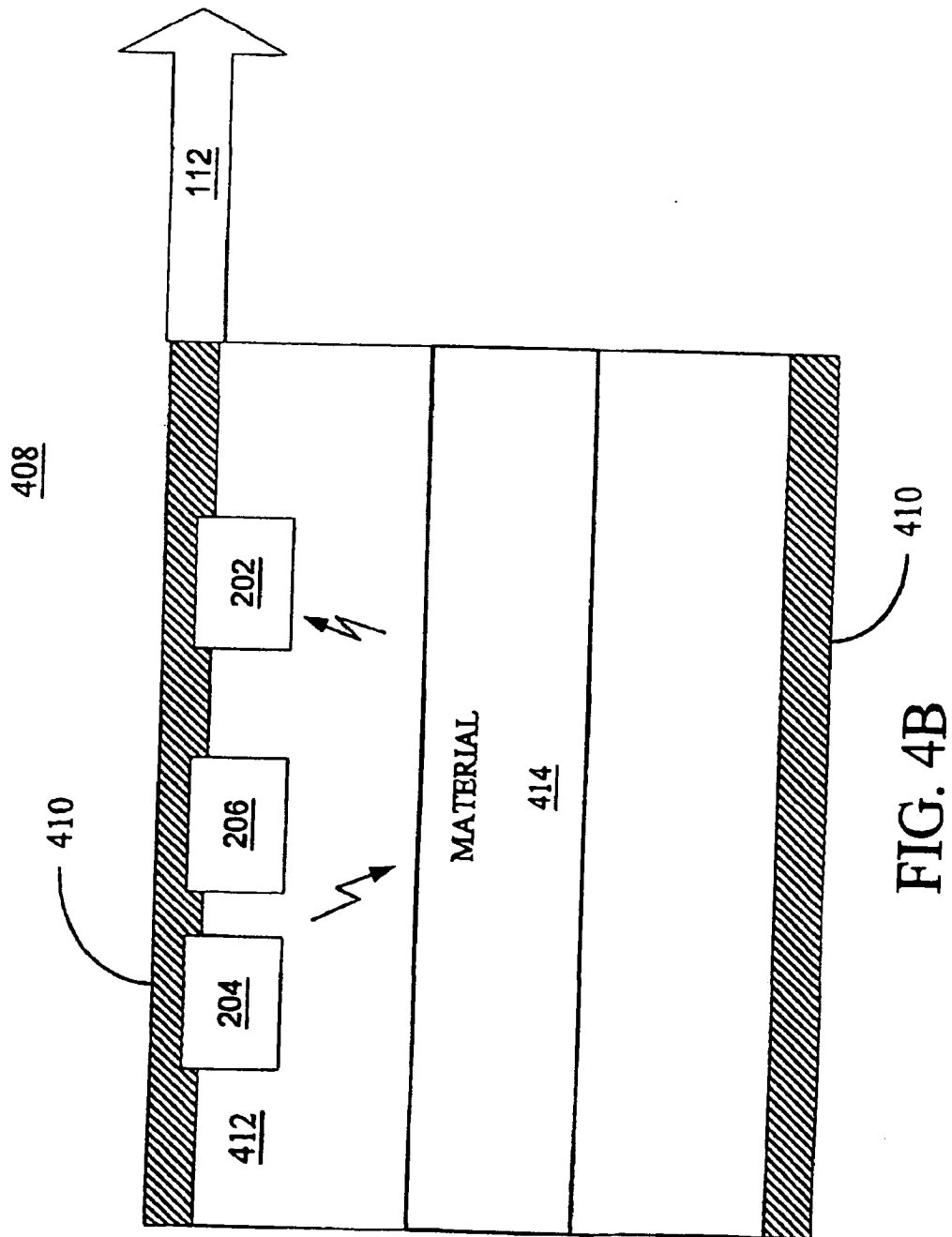

FIG. 4B

500

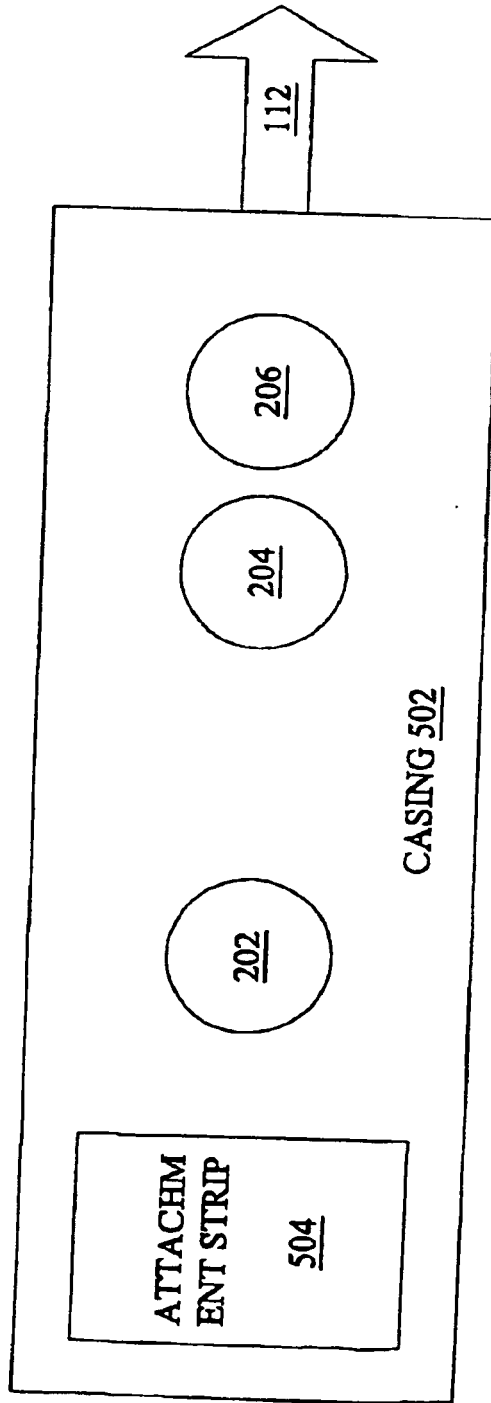

FIG. 5

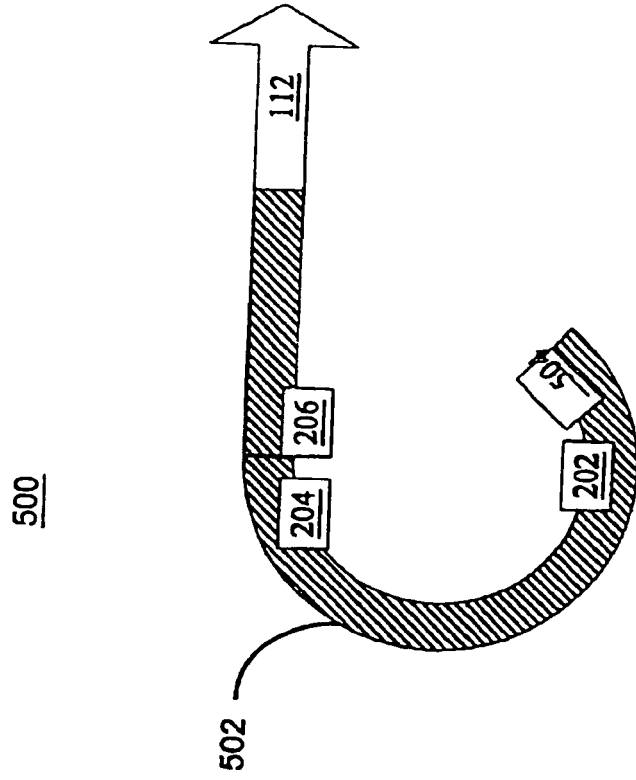

FIG. 6

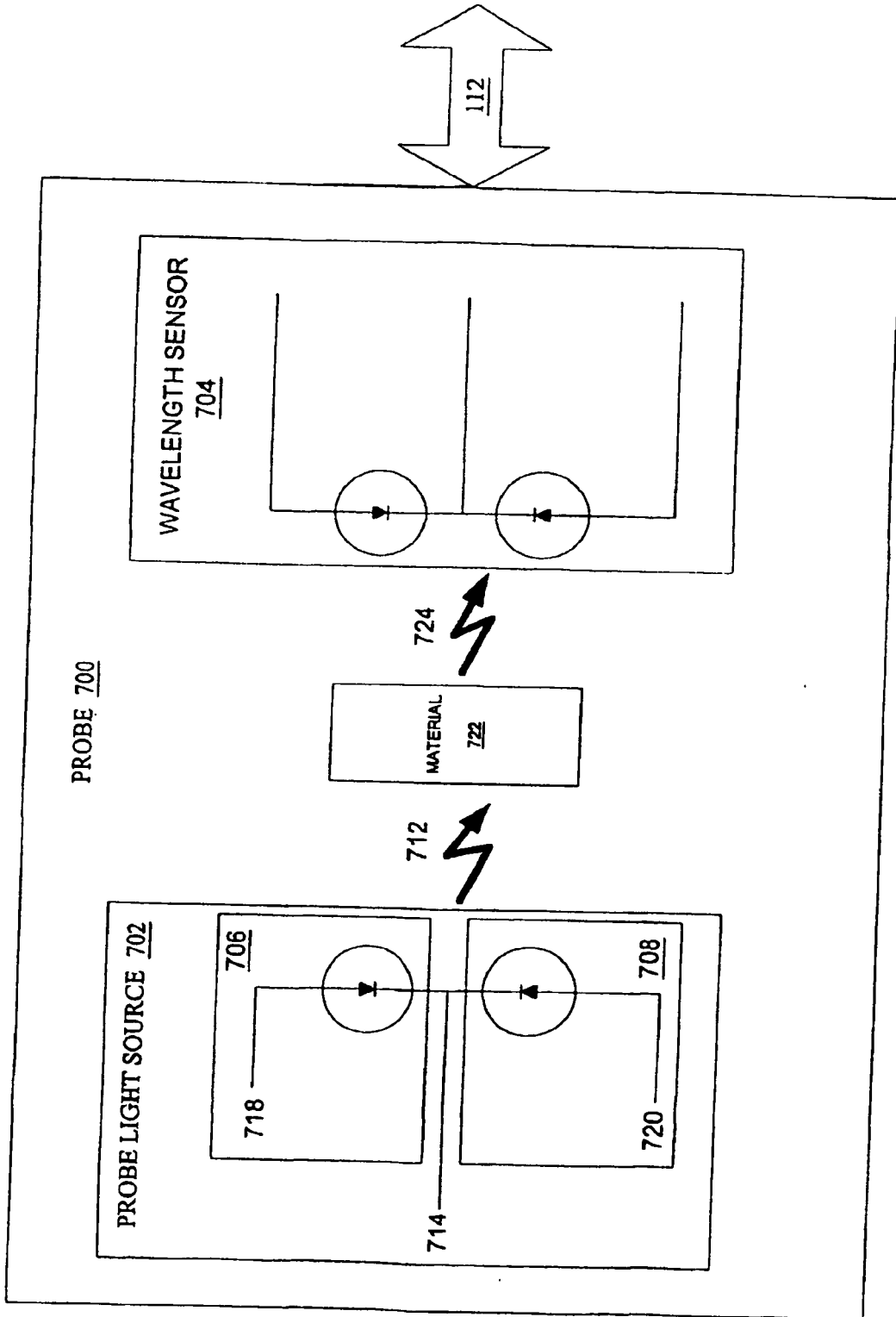

FIG. 7

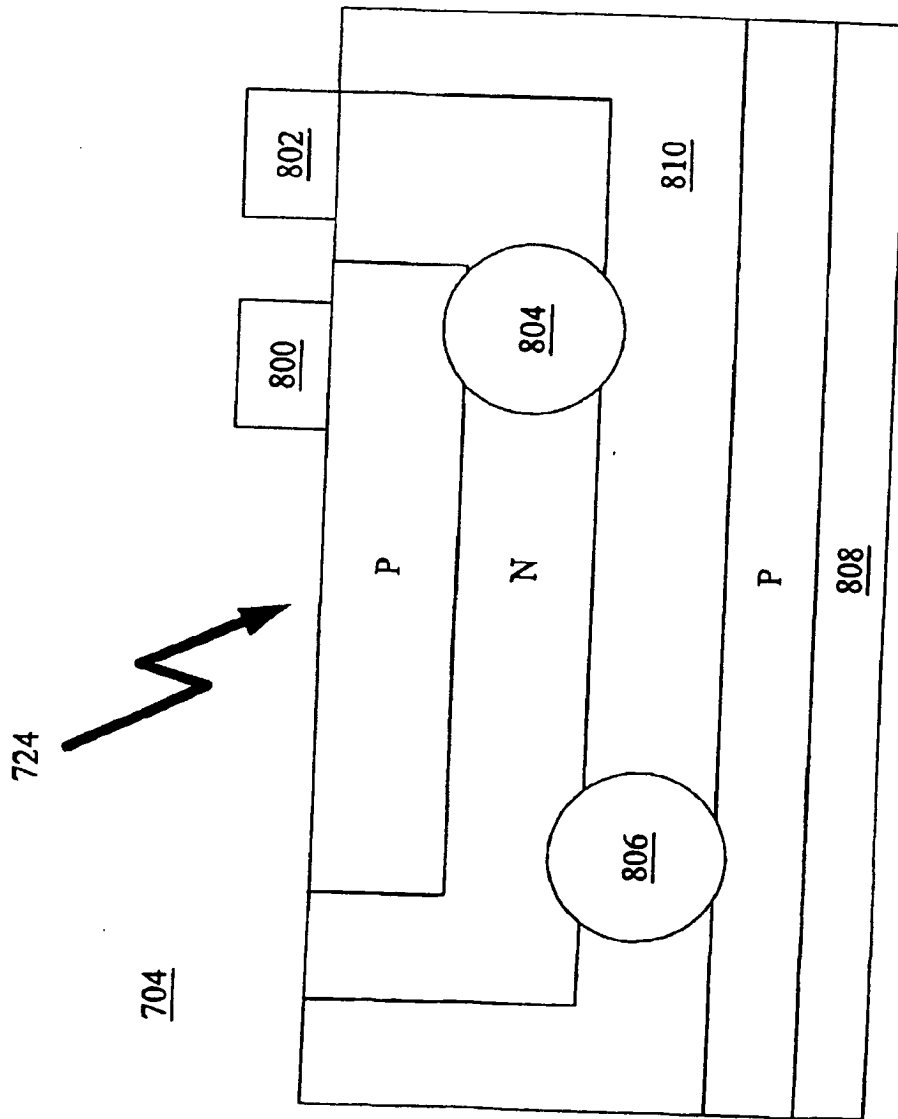

FIG. 8

9/15

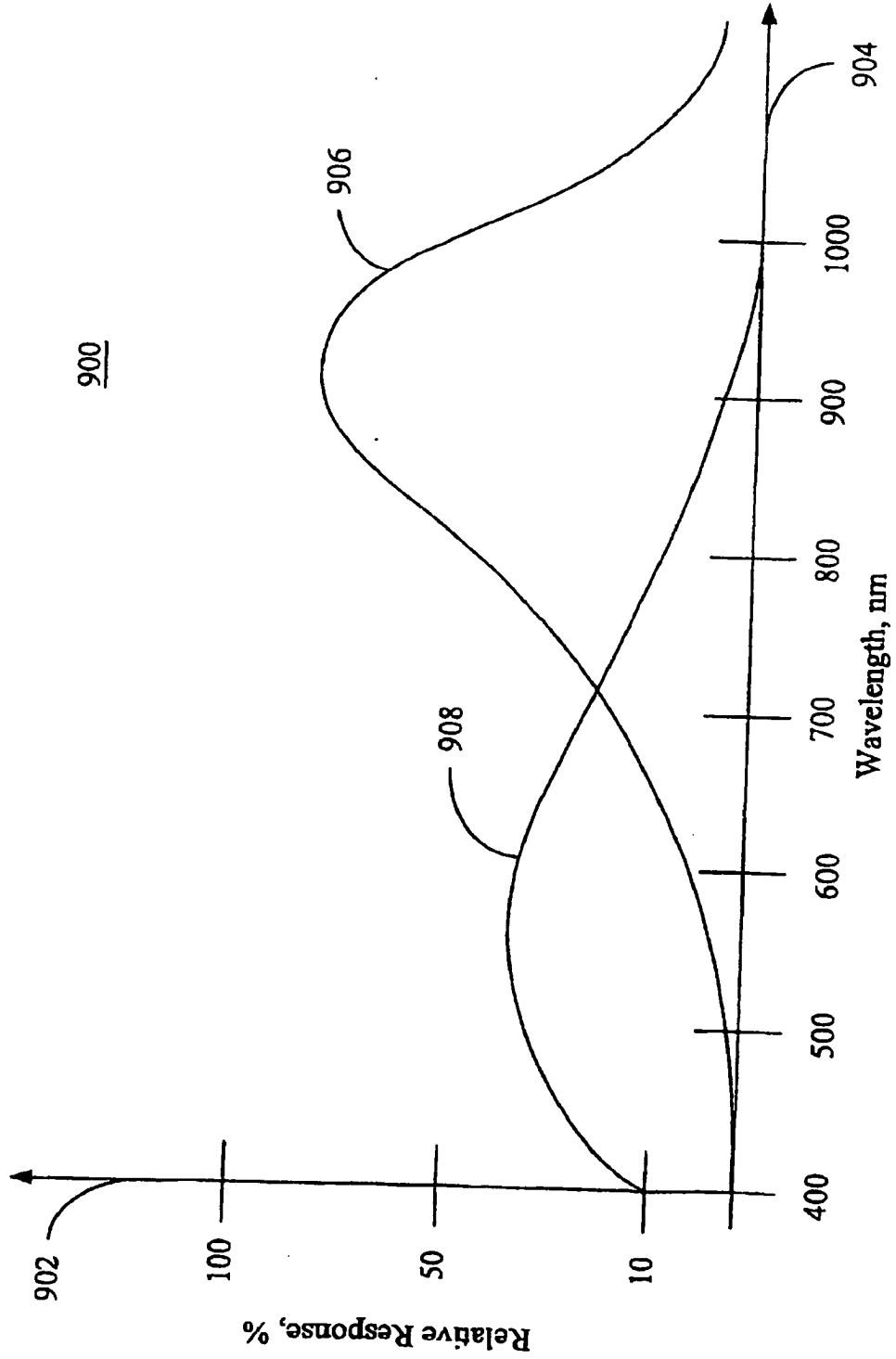

FIG. 9

10/15

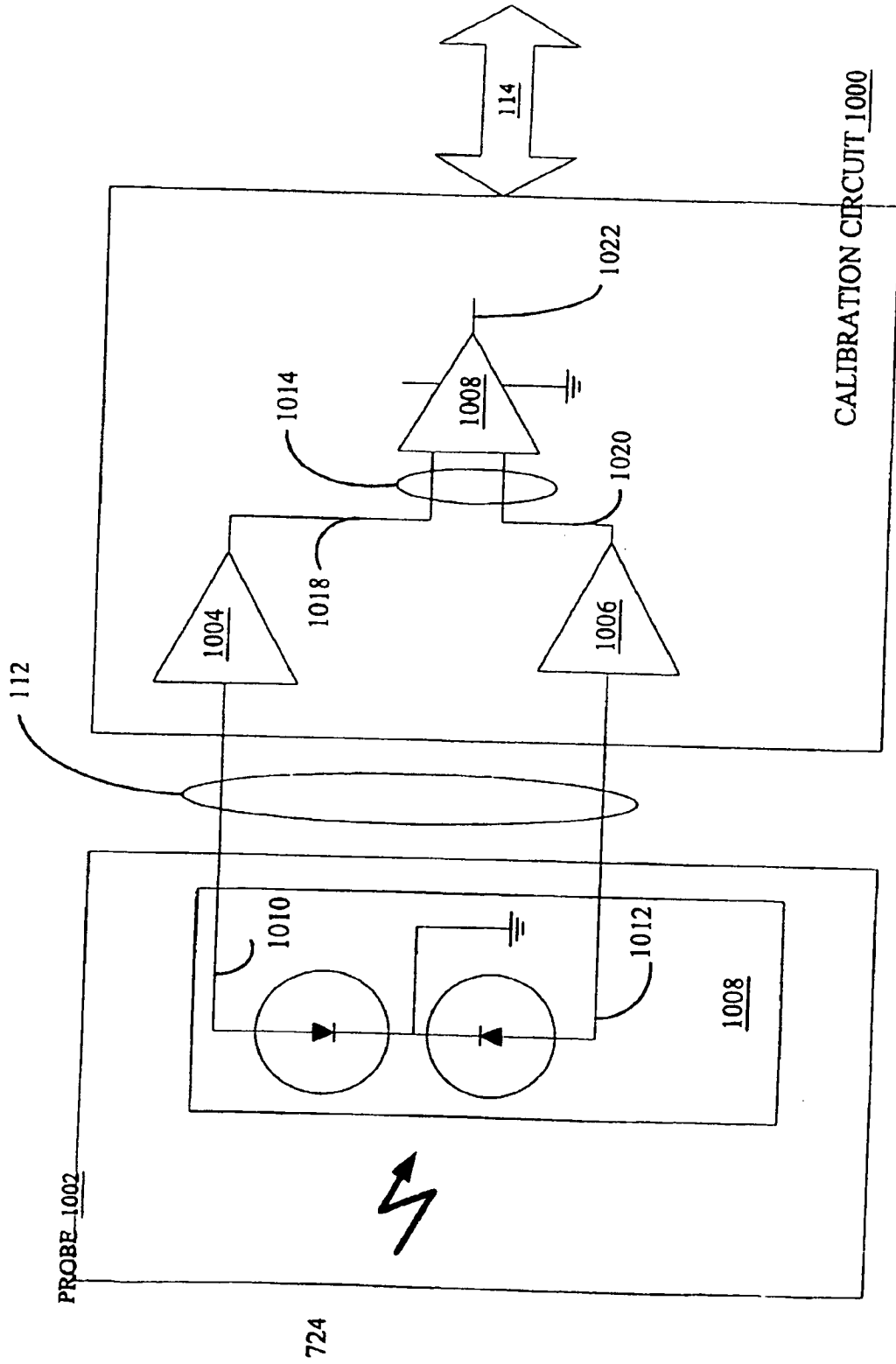

FIG. 10

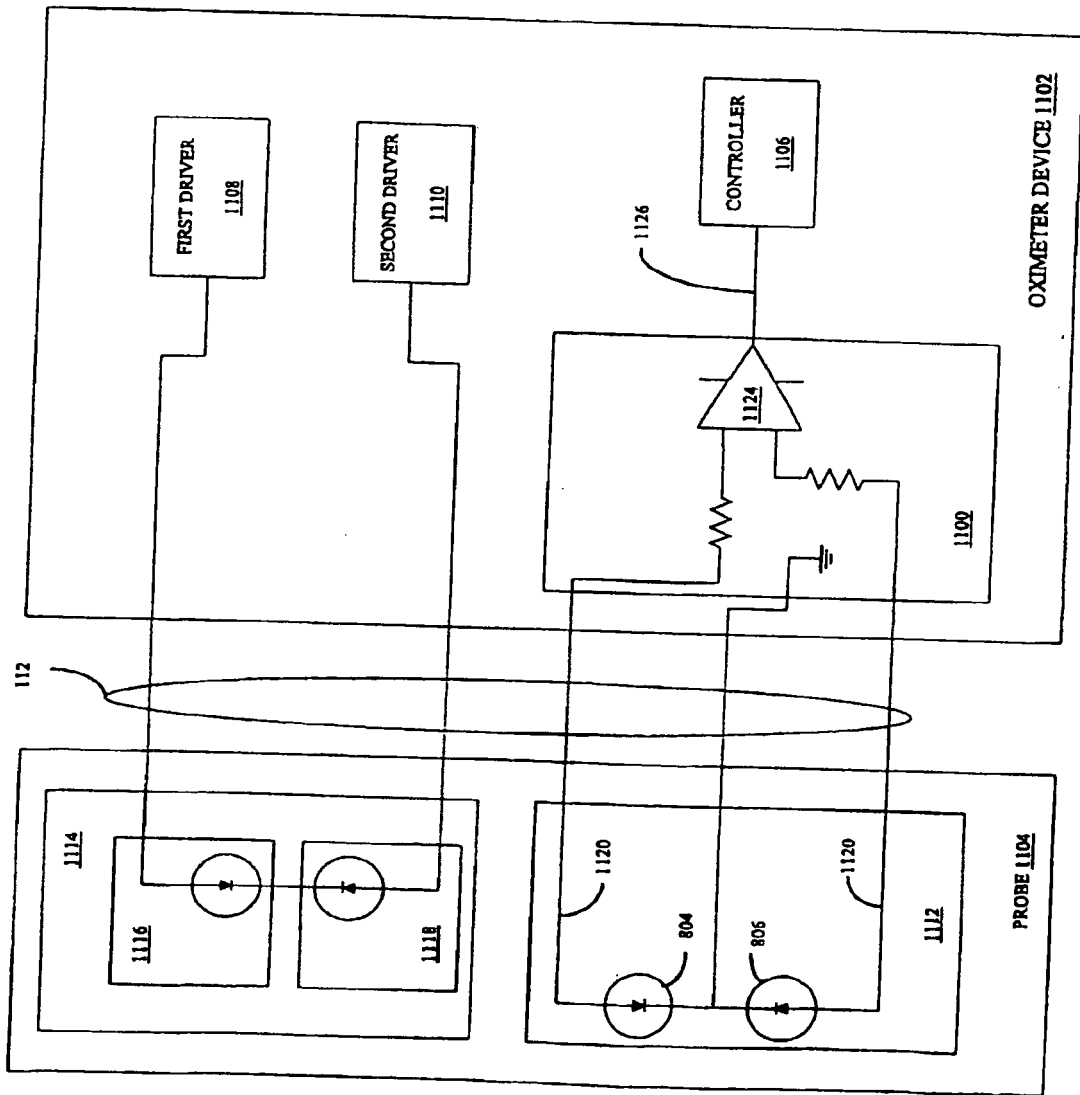

FIG. 11

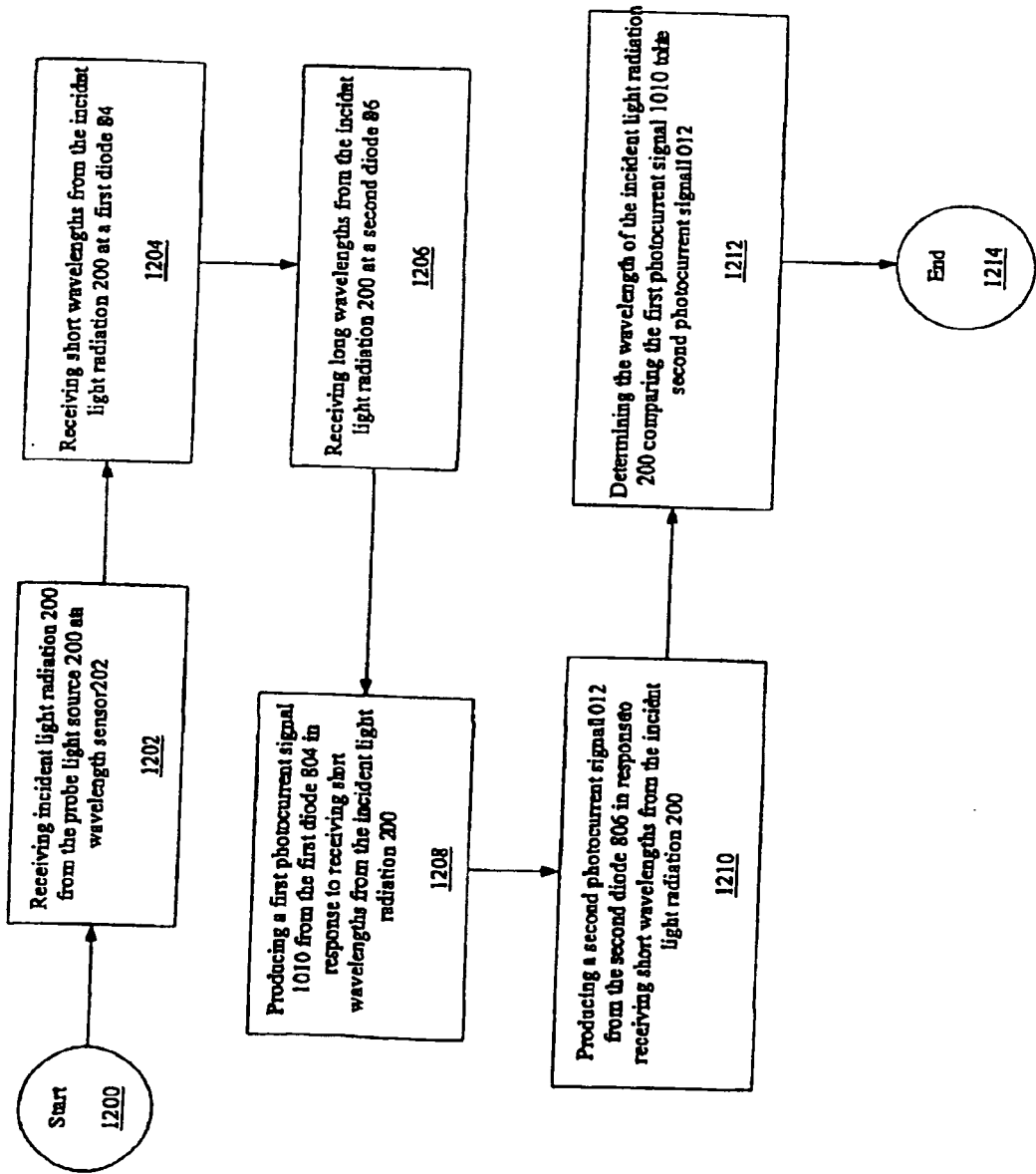

FIG. 12

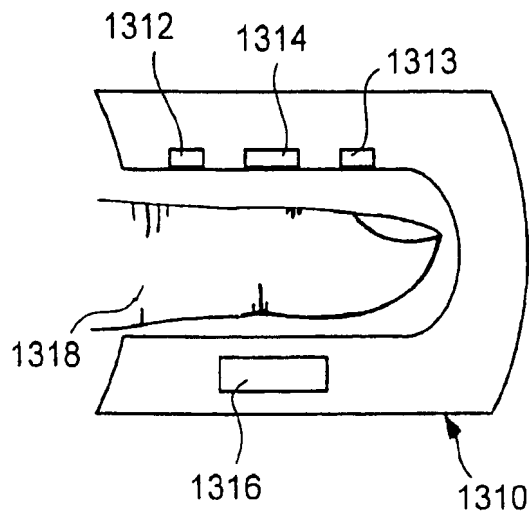

Fig. 13

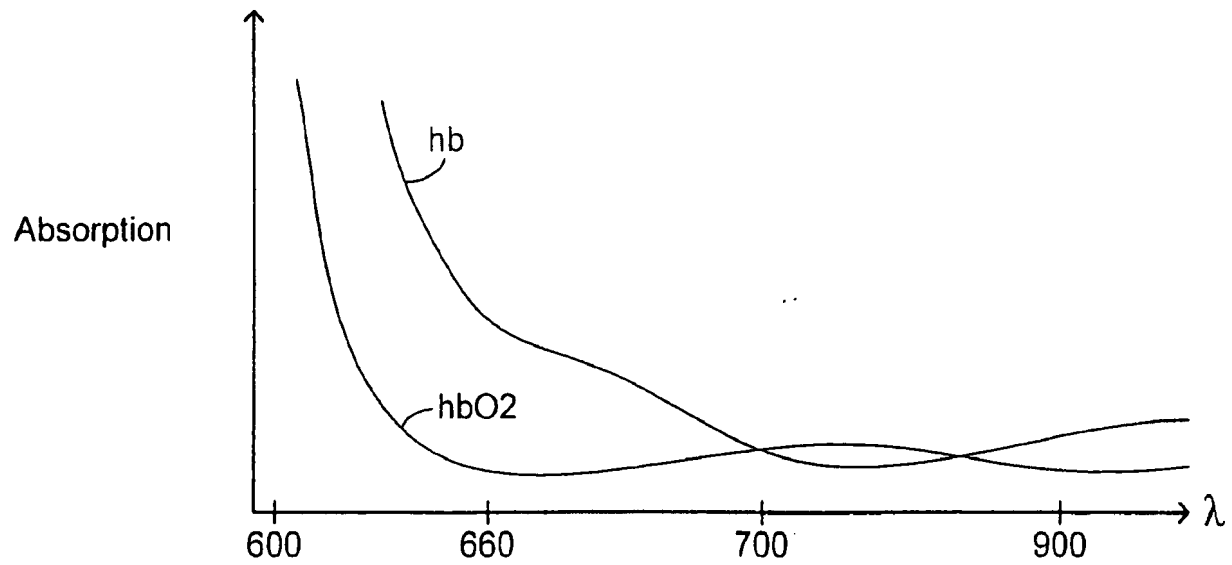

Fig. 14

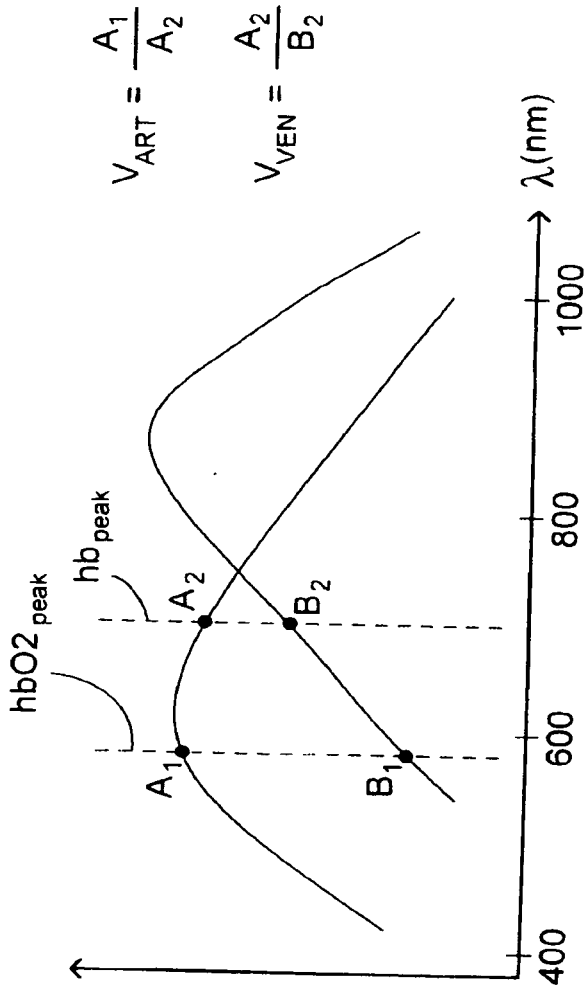

Fig. 15

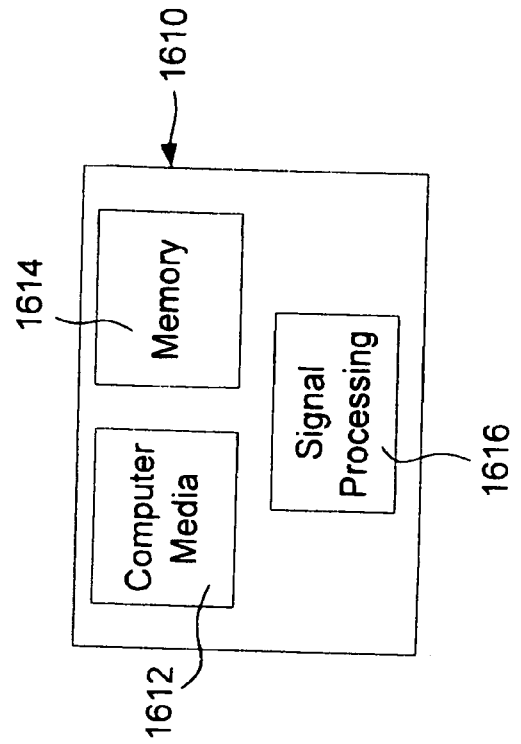

Fig. 16

