



- (51) **International Patent Classification:**
B05B 1/24 (2006.01)
- (21) **International Application Number:**
PCT/NZ2013/000206
- (22) **International Filing Date:**
14 November 2013 (14.11.2013)
- (25) **Filing Language:** English
- (26) **Publication Language:** English
- (30) **Priority Data:**
603629 15 November 2012 (15.11.2012) NZ
- (71) **Applicant:** POLYGONE LIMITED [NZ/NZ]; 52 Esplanade, Sumner, Christchurch 8081 (NZ).
- (72) **Inventors:** IRWIN, Aaron Melville; 52 Esplanade, Sumner, Christchurch 8081 (NZ). IRWIN, Tracie Marie; 52 Esplanade, Sumner, Christchurch 8081 (NZ). MAKURU, John Ngatae; 12 Woodend Road, Woodend, Christchurch, 7610 (NZ).
- (74) **Agents:** PAIRMAN IP et al.; P.O Box 33252, Christchurch 8244 (NZ).
- (81) **Designated States** (*unless otherwise indicated, for every kind of national protection available*): AE, AG, AL, AM, AO, AT, AU, AZ, BA, BB, BG, BH, BN, BR, BW, BY,

BZ, CA, CH, CL, CN, CO, CR, CU, CZ, DE, DK, DM, DO, DZ, EC, EE, EG, ES, FI, GB, GD, GE, GH, GM, GT, HN, HR, HU, ID, IL, IN, IR, IS, JP, KE, KG, KN, KP, KR, KZ, LA, LC, LK, LR, LS, LT, LU, LY, MA, MD, ME, MG, MK, MN, MW, MX, MY, MZ, NA, NG, NI, NO, NZ, OM, PA, PE, PG, PH, PL, PT, QA, RO, RS, RU, RW, SA, SC, SD, SE, SG, SK, SL, SM, ST, SV, SY, TH, TJ, TM, TN, TR, TT, TZ, UA, UG, US, UZ, VC, VN, ZA, ZM, ZW.

- (84) **Designated States** (*unless otherwise indicated, for every kind of regional protection available*): ARIPO (BW, GH, GM, KE, LR, LS, MW, MZ, NA, RW, SD, SL, SZ, TZ, UG, ZM, ZW), Eurasian (AM, AZ, BY, KG, KZ, RU, TJ, TM), European (AL, AT, BE, BG, CH, CY, CZ, DE, DK, EE, ES, FI, FR, GB, GR, HR, HU, IE, IS, IT, LT, LU, LV, MC, MK, MT, NL, NO, PL, PT, RO, RS, SE, SI, SK, SM, TR), OAPI (BF, BJ, CF, CG, CI, CM, GA, GN, GQ, GW, KM, ML, MR, NE, SN, TD, TG).

Declarations under Rule 4.17:

- *as to applicant's entitlement to apply for and be granted a patent (Rule 4.17(ii))*

Published:

- *without international search report and to be republished upon receipt of that report (Rule 48.2(g))*

(54) **Title:** HOT OIL SPRAYER

Figure 1

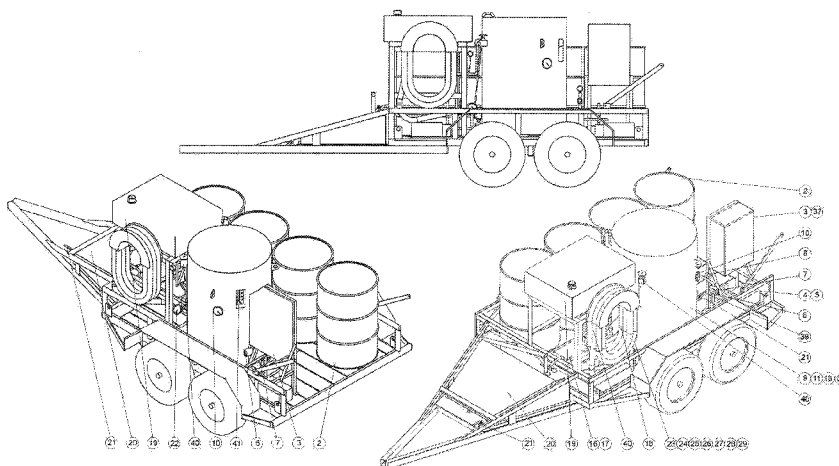

(57) **Abstract:** The invention relates to a device that reduces the volume of polystyrene. The apparatus described comprises a heating means to heat a sample of oil to a temperature below the boiling point of the oil and a means to direct the heated oil on a sample of waste polystyrene. The oil acts on the polystyrene to reduce the aerated form of the polystyrene to a more non aerated form which is smaller in volume and which is acceptable for dumping at a landfill site. The apparatus may be attached to a moveable vehicle for ease of transportation. The invention also relates to a method of reducing the volume of a sample of polystyrene to a more manageable form.



Hot Oil Sprayer

Field of the Invention

The invention relates to a method of reducing the amount of polystyrene which is destined for landfill. In particular the invention relates to a method of reducing
5 polystyrene to a form that is able to be disposed of in landfill. The invention also relates to an apparatus for reducing the amount of polystyrene that is committed to landfill.

Background to the Invention

In February 2011, a large earthquake struck Christchurch in New Zealand. Due to
10 the strength of this earthquake, many commercial and private buildings had to be demolished. Many of the buildings which had to be demolished were constructed using polystyrene as a form of insulation and cladding.

Polystyrene cannot be taken to landfill. Therefore demolition of buildings had to be halted until such time as an appropriate disposal method was identified.

15 It has been estimated that in the demolition required in Christchurch alone, enough polystyrene was present in the buildings requiring demolition to fill several large rugby stadiums when laid flat from end to end and ground to roof level.

The inability to dispose of the polystyrene is of major concern.

20 In addition, demolition companies are now stock piling polystyrene in commercial premises throughout the region as the cost to dump this product is making the work cost prohibitive.

The issues being that the product does not decompose / break down and is toxic in its aerated form.

25 Currently it is being dumped into a restricted landfill at Cape Valley. The cost of dumping this product is \$1,900.00 per tonne and the tonne includes whatever it is attached to, for example, concrete.

This has increased the cost of demolitions significantly and has slowed the progress of the rebuild.

Object of the Invention

It is therefore an object of the invention to provide an apparatus and a method for
5 the safe disposal into landfill of demolition material that contains polystyrene or to
at least provide the public with a useful choice.

Summary of the Invention

The invention was developed from an idea of breaking the polystyrene down from
its aerated form to reduce the cost of demolition and speed up the rebuild process.

10 The invention provides an apparatus for reducing the volume of polystyrene
comprising:

a heating means to heat oil to a temperature below the boiling point of the oil;

a means of directing the heated oil from the heating means to a spray means; and

a spray means through which the oil is directed onto a sample of polystyrene.

15 Preferably the spray means includes a spray delivery nozzle.

Preferably the spray means includes a quick release coupling to allow interchange
of spray delivery nozzles.

The spray delivery nozzle may include a spray lance to direct oil in an even
manner onto the polystyrene.

20 The spray means may also include a spear lance which is adapted to be inserted
into concrete slabs that contain polystyrene inside.

The heating means preferably includes a heat exchanger which heats up a thermal
heating fluid which in turn heats the oil.

More preferably the heat exchanger includes two chambers: a first chamber in
25 which the thermal heating fluid is maintained at a constant temperature; and a

second chamber which the oil passes through as it is heated by the thermal heating fluid.

- The apparatus may include a heat pump to recirculate hot thermal fluid from the top of the heat exchanger through a delivery hose and back to the bottom of the
- 5 heat exchanger to reduce the heat loss of the thermal fluid and to prevent it cooling when the spray means is inactive.

The apparatus may be built onto a trailer or the like for ease of movability.

The invention also provides a method of reducing the volume of a sample of polystyrene comprising the steps of:

- 10 heating an oil to a temperature slightly below the boiling point for the oil;
- directing the oil through an oil flow means and towards the sample of polystyrene to be treated; and
- spraying the heated oil onto the polystyrene.

- 15 Preferably the oil is heated to a temperature of between 210-250°C and more preferably between 220-240°C.

Preferably the oil is selected from the group consisting of: corn, canola, groundnut, linseed, olive, safflower, sesame, soybean, sunflower and rapeseed.

- 20 Preferably the oil is crude, refined and bleached or refined bleached and deodorised.

The method may be performed using the apparatus according to the present invention.

- 25 In a further embodiment of the invention the oil sprayer is used as a permanent fixture rather than being transportable. For example and according to a further aspect of the invention there is provided a hot oil sprayer which is a permanent feature of a landfill or the like. In this aspect, the hot oil sprayer may be set up to
- 30 spray over a movable belt type of system, for example a conveyor belt system. The product may be moved along the conveyor belt and pass under a nozzle system

which may comprise a single or a system of nozzles. The nozzles are adapted to spray the oil onto the polystyrene. The oil may then fall down onto a grease trap and may be recycled.

5 The product is environmentally friendly and extremely cost effective when compared to the current disposal system.

The product has been tested and approved for hardfill and landfill disposal. There are no harmful toxins or emissions during the treatment process.

10 The product continues to breakdown long after the process has been completed. It can be used in a concrete crusher to be broken down even further and re used along with crushed concrete for other construction projects.

This invention has gained worldwide interest as the use of polystyrene in packaging has become prolific however the dumping of the product is a cause of great concern and cost.

Brief Description of the Drawings

15 The invention will now be described by way of example only and with reference to the drawings in which:

Figure 1 is an overview drawing of the apparatus when sitting on a movable trailer;

Figure 2 is a diagrammatic representation of the apparatus; and

20 Figure 3 is a more detailed diagrammatic view of the heat exchanger.

Detailed Description of the Invention

As shown in Figure 1, the apparatus comprises the following features:

25 1. Foot valve which prevents any product in the suction hose from pouring back out of the hose when it is removed from the product drum;

2. Product drum which is a container that is used to store the unused product. The product drum may be secured to a trailer or the like for ease of moving the apparatus.
3. Electrical cabinet and controllers. The electrical cabinet stores the control equipment. Both the product pump and the recirculation heating pump can be operated from the cabinet. The control system uses the temperature reading from the PT100 probe to turn the electrical elements on and off. If the PT100 fails at any time, an over temperature snap disc switch located on the side of the heat exchanger will shut down the heating system. The temperature of the heating fluid can be adjusted on the control unit; however in use the maximum temperature has been limited to 250°C. The main supply connection is a 5 pin 32 Amp 3 phase connection and there is an auxiliary single phase connection available.
4. Product pump which is used to draw cold product oil from the product drum and pump it through the heat exchanger to the spraying lance;
5. Product pump electric motor which is used to drive the product pump and is controlled via the control panel;
6. Digital; flow totalizer which is battery operated and digitally displays the total amount in litres of product oil that passes through the heat exchanger and out of the spray lance;
7. Pressure release valve which is used to control the product pressure beyond the product pump. The pressure relief valve is set so that it will relieve at 45 psi. Any product that is relieved will be returned to the product drum.
8. Product pressure gauge which indicates the pressure that is within the product line;

9. PT100 temperature probe which is used to measure the temperature of the thermal heating fluid. The reading from the PT100 is used by the control unit to operate the heating elements;
- 5 10. Temperature gauge which gives a mechanical temperature reading of the thermal heating fluid; the thermometer is used to check the calibration of the PT100. Being a mechanical gauge this ensures that temperature readout of the thermal fluid is available at all times;
- 10 11. Snap disc thermostat which is used as a safety shut off for the system. If the PT100 or control system fails, the snap disc will activate at 280°C and shut down the heating system;
12. High temperature needle valve which is used to drain the heat exchanger of the thermal heating fluid. This is only done when the system is off and cold;
- 15 13. Electrical heating elements which are used to heat the thermal heating fluid to operating temperature and then used to maintain the temperature of the thermal heating fluid during the delivery process;
- 20 14. Stainless steel braided Teflon hose which is rated to 260°C (continuous) and is used to separate the pressure gauge from the pipework. Separating the gauge reduces the temperature of the liquid that interacts with the gauge.
15. Thermal fluid pressure gauge which is used to measure the pressure of the thermal heating fluid that is passed through the delivery hose and back into the heat exchanger;
- 25 16. Heating pump electric motor which drives the recirculation heating pump and is controlled via the control panel;
17. Heating pump which recirculates the hot thermal fluid from the top of the heat exchanger through the delivery hose and then back into the bottom of the heat exchanger. Recirculating the thermal fluid through the hose

reduces the heat loss of the product fluid and prevents the product fluid cooling while the spray gun is not operating;

- 5 18. Safety release valve. The system operating pressure is 45 psi. If the product oil pressure becomes greater than the operating pressure then this valve will open, making sure the product pressure never exceeds 60 psi. Excess product will be vented into the stops tank;
19. Header tank which allows all the air in the heat exchanger to be removed and provides additional storage for the thermal heating fluid as it expands with the change in temperature;
- 10 20. Slops tank is a 145 litre stainless steel tank that can be used for collecting any product oil spray when checking the temperature at the spraying nozzle/ Any oil bypassed from the pressure relief valve also ends up in the slops tank;
- 15 21. ½" ball valve: one of the ball valves is used to isolate the heat exchanger from the inlet pipework during maintenance, while the second ball valve is used as a drain for the slops tank;
22. Pipework temperature gauge which is used to measure the temperature of the product exiting the heat exchanger'
- 20 23. ¼" stainless steel braided Teflon hose which is rated to 2600C (continuous) and three lengths of hose are used to transport the product oil to the spray lance, as well as transport the thermal heating fluid to the lance and back to the heat exchanger;
24. 232MB steam Queen hose which is used as an external sleeve to house the three stainless steel braided Teflon hoses up to the spray lance;
- 25 25. Fibre glass insulation tape which is used to further insulate the product hose and is wrapped twice around the 232MB steam queen hose;

26. Canvas hose wrap which provides a protective surface for the fibre glass insulated product hose;
27. Aluminium junction block which provides a junction point for the three Teflon hoses at the spray lance. The thermal fluid is redirected back to the heat exchanger at this point;
28. Digital thermometer which is battery operated and provides a temperature reading of the product just before it enters into the spray lance;
29. ¼" quick release coupling which allows the spray lance to be quickly changed to a spear lance;
30. Trigger gun which provides an easy to operate open close mechanism for the spraying lance;
31. Spraying lance which provides a means of spraying the product oil onto the polystyrene;
32. Spray nozzle which forces the oil into a fan which can be sprayed over the polystyrene;
33. ¼" high temperature needle valve which provides a means of shutting off the oil when the hose is coupled to the spear lance;
34. Spear lance which is used by inserting it into concrete slabs that have a polystyrene core. Spraying the product oil into the space removes the polystyrene around the lance;
35. Spray nozzle. Spray nozzles are fitted along the shaft of the spear lance to provide discernment of the oil over a longer distance to remove all polystyrene inside the concrete slabs;
36. Heat exchanger which is the main body of the hot oil system operation. The heat exchanger has two chambers, one in which a thermal heating fluid is maintained at a constant temperature and a second chamber where the oil passes through to be heated from 0 degrees C up to 255° C. The

thermal heating fluid is heated via the electrical elements and the thermal fluid in turn heats the oil;

37. Electrical master switch which provides a means of electrically isolating the system from any power source;
- 5 38. ½" Mack union which is used to make assembling of the pipework easier and to account for any slight misalignment between pipes;
39. ¼" ball valve which drains the oil from the heat exchanger for servicing;
40. ½" gate valve which isolates the inlet and outlet pipework for the thermal heating fluid heat recirculation pipework during servicing;
- 10 41. Sight glass which is a glass window which allows the operator to monitor the heat transfer fluid;
42. Tandem axle trailer which provides the platform upon which the hot oil system is installed. It provides mobility and allows the entire system to be transported to any potential worksite. The trailer in this case has been
- 15 modified from a standard digger transporter to accommodate the mounting of all the equipment necessary for the system to operate.

Referring now to Figure 2 the following features are shown:

1. A ¼" foot valve;
2. A product drum;
- 20 3. An electrical control cabinet;
4. A ½" product ump;
5. A three phase electrical motor;
6. A digital flow totalizer
7. A pressure relief valve;

8. A pressure gauge;
9. A PT100 temperature probe;
10. A temperature thermometer;
11. A snap disc thermostat;
- 5 12. A ½" high temperature needle valve;
13. An electrical heating element;
14. A ¼" stainless steel braided Teflon hose;
15. A pressure gauge;
16. A single phase electric motor;
- 10 17. A 1" heating pump;
18. A safety relief valve;
19. A 62 litre header tank;
20. A slops tank;
21. A ½" ball valve;
- 15 22. A thermal temperature gauge;
23. A ¼" stainless steel braided Teflon hose;
24. 1" 232MB steam queen hose;
25. 75mm fibre glass insulation tape;
26. Canvas hose wrap;
- 20 27. Junction block;
28. Digital thermometer;

29. ¼" quick release coupling;
30. Trigger gun;
31. Spraying lance;
32. Spray nozzle;
- 5 33. ¼" high temperature needle valve;
34. Spear lance;
35. Spray nozzle;
36. Tube heat exchanger;
37. Master on/off switch;
- 10 38. ½" Mack union (steel);
39. ¼" ball valve;
40. ½" gate valve;
41. Sight glass; and
42. Trailer.
- 15 The heat exchanger is shown in detail in Figure 3 and includes:
- A product flow outlet (A) and a product relief valve (B). Also shown is a header tank (C), containing thermal heating fluid (D). The heating element is shown at (E) with the heat exchange tubes (F). The product flow intake is shown at (G).
- 20 The system is simple to use:
- Check the unit is on level ground;
 - Check the unit is in an area with suitable ventilation;

- Check the level of thermal heating fluid in the header tank. There should be 15-20mm of fluid when the system is cold;
- Place the suction(siphon tube) into the desired product drum;
- Connect the electrical 3 phase connection;
- 5 • Check the lance is stowed in the temperature test pocket and the trigger is of and locked;
- Turn on the master electrical supply switch;
- Turn on the product pump. The pump will circulate through the pressure relief valve back into the product drum until the trigger gun is pulled;
- 10 • Turn on the heat recirculation pump. The pump will circulate thermal heating fluid from the top of the exchanger through the hose and back into the heat exchanger.
- While the spray lance is directed into the temperature test pocket, pull the trigger on the hand lance and spray into the slops tank. Allow cold product to flow through the heat exchanger to ensure there are no air pockets during the initial heating period;
- 15 • Release the hand trigger and lock;
- Turn on the heating control system;
- Allow the system to heat up – constantly monitor the temperature and pressure gauges to ensure the system is operating normally. The thermal heating fluid will expand and the oil level in the header tank will rise. If the fluid starts to come out of the filler breather cap, immediately shut down the heating system;
- 20 • Once the temperature is at the desired working level (about 250°C), while the spray lance is directed into the temperature test pocket, pull the gun
- 25

trigger on the hand lance and spray into the slops tank. The temperature gauge will show the temperature of the sprayed product;

- 5 • Once the temperature indicator shows the oil to be at the desired operating temperature (220-240°C) release the gun trigger and ensuring there is no oil spraying, remove the gun from the test pocket;
- Start spraying – ensure the spray is directed in an outward direction at a minimum distance of safely from the operator;
- To shut down the system, stow the spray lance into the slops tank pocket;
- Turn off the heating system;
- 10 • Turn off the product pump and the heat recirculation pump;
- Record the amount of product used if desired (displayed on the flow meter);
- Turn off the electrical master supply switch;
- Disconnect the electrical connection;
- 15 • Stow the suction/siphon tube and replace the cap in the top of the product drum;
- Disconnect the spraying lance from the hose and stow the lance;
- Allow the system to cool down;
- While cooling it may be necessary to occasionally pull the spray trigger to
20 allow air back into the system as the product cools and contracts.
-

Whilst the invention has been described with reference to the particular embodiment shown in the drawings, it will be appreciated that various modification and improvement may be made to this embodiment without departing from the scope of the invention as set out in this specification.

- 5 For example, the oil sprayer may not be positioned on a trailer type of unit but could be permanent or semi-permanent. The polystyrene to be treated may move on a conveyer belt beneath a spray means and the hot oil sprayed onto the polystyrene as it moves under the spray means.

10 **Industrial Applicability**

- 15 The invention provides an apparatus and method which can be used to reduce the amount of polystyrene waste product being sent to a landfill. The apparatus is designed to spray hot oil onto a sample of waste polystyrene. The pressure and type of oil used enable the polystyrene to be reduced from its aerated form to a form more able to be disposed of in landfill. The method and apparatus thus reduces the amount of waste polystyrene material being dumped in landfill and provides a more environmentally friendly method of disposing of this waste product.

Claims

1. An apparatus for reducing the volume of polystyrene comprising:
a heating means to heat oil to a temperature below the boiling point of the oil;
5 a means of directing the heated oil from the heating means to a spray means; and
a spray means through which the oil is directed onto a sample of polystyrene.
- 10 2. A device according to claim 1 in which the spray means includes a spray delivery nozzle.
3. An apparatus according to claim 2 in which the spray means includes a quick release coupling to allow interchange of spray delivery nozzles.
4. An apparatus according to claim 2 in which the spray delivery nozzle includes a spray lance to direct oil in an even manner onto the polystyrene.
- 15 5. An apparatus according to claim 4 in which the spray means includes a spear lance which is adapted to be inserted into concrete slabs that contain polystyrene inside.
- 20 6. An apparatus according to any one of the preceding claims in which the heating means includes a heat exchanger which heats up a thermal heating fluid which in turn heats the oil.
- 25 7. An apparatus according to any one of the preceding claims in which the heat exchanger comprises two chambers: a first chamber in which the thermal heating fluid is maintained at a constant temperature; and a second chamber which the oil passes through as it is heated by the thermal heating fluid.
8. An apparatus according to any one of the preceding claims which also includes a heat pump to recirculate hot thermal fluid from the top of the

heat exchanger through a delivery hose and back to the bottom of the heat exchanger to reduce the heat loss of the thermal fluid and to prevent it cooling when the spray means is inactive.

- 5
9. An apparatus according to any preceding claim which is built onto a trailer, or the like for ease of mobility from one location to another.
10. A method of reducing the volume of a sample of polystyrene comprising the steps of:
- 10
- heating an oil to a temperature slightly below the boiling point for the oil;
- directing the oil through an oil flow means and towards the sample of polystyrene to be treated; and
- spraying the heated oil onto the polystyrene.
11. A method according to claim 10 in which the oil is heated to a temperature of between 210-250°C and more preferably between 220-240°C.
- 15
12. A method according to claim 10 or claim 11 in which the oil is selected from the group consisting of: corn, canola, groundnut, linseed, olive, safflower, soybean, sunflower and rapeseed.
13. A method according to any one of claims 10-12 in which the oil is crude, refined and bleached or refined bleached and deodorized.

Figure 1

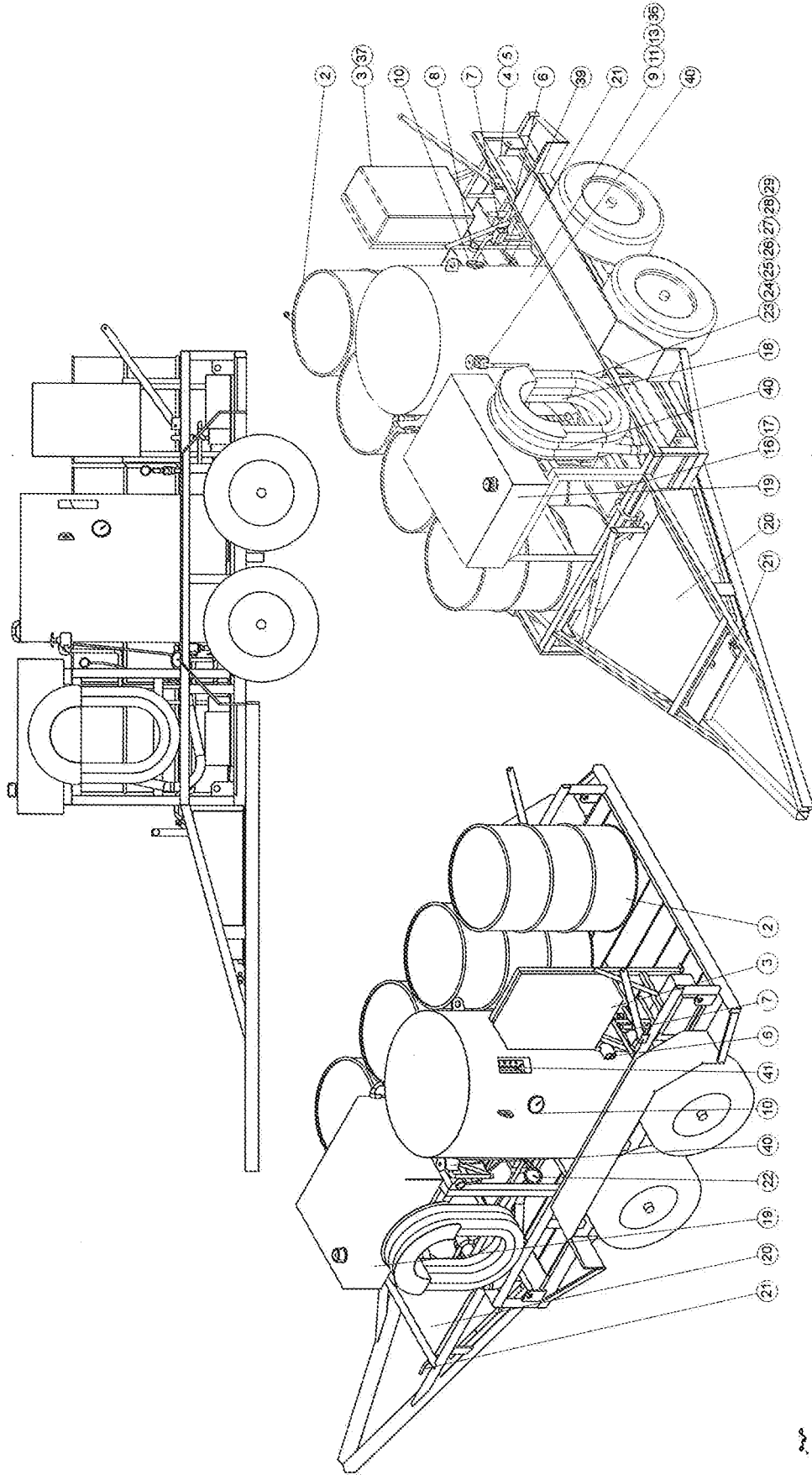

Figure 2

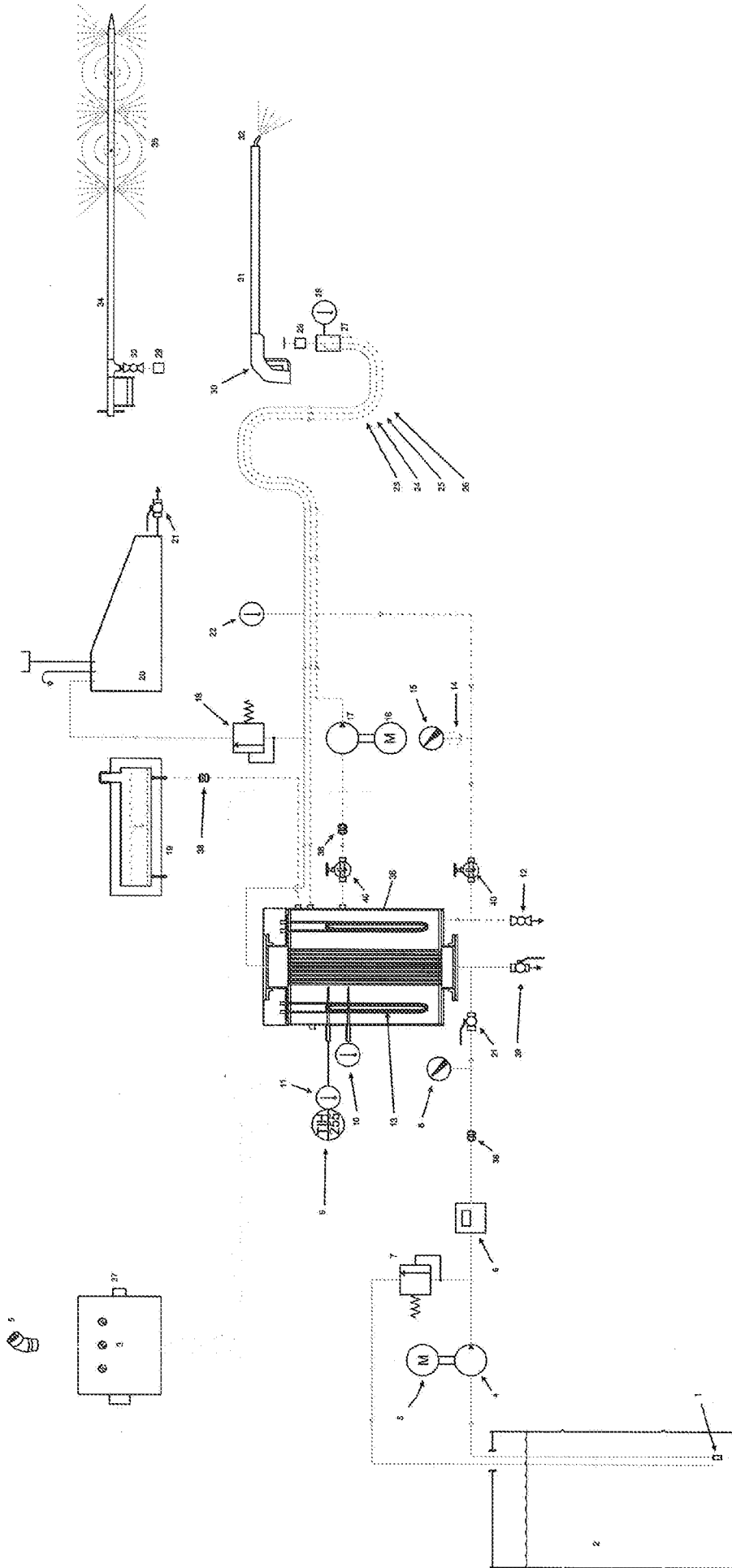

FIGURE 3

