

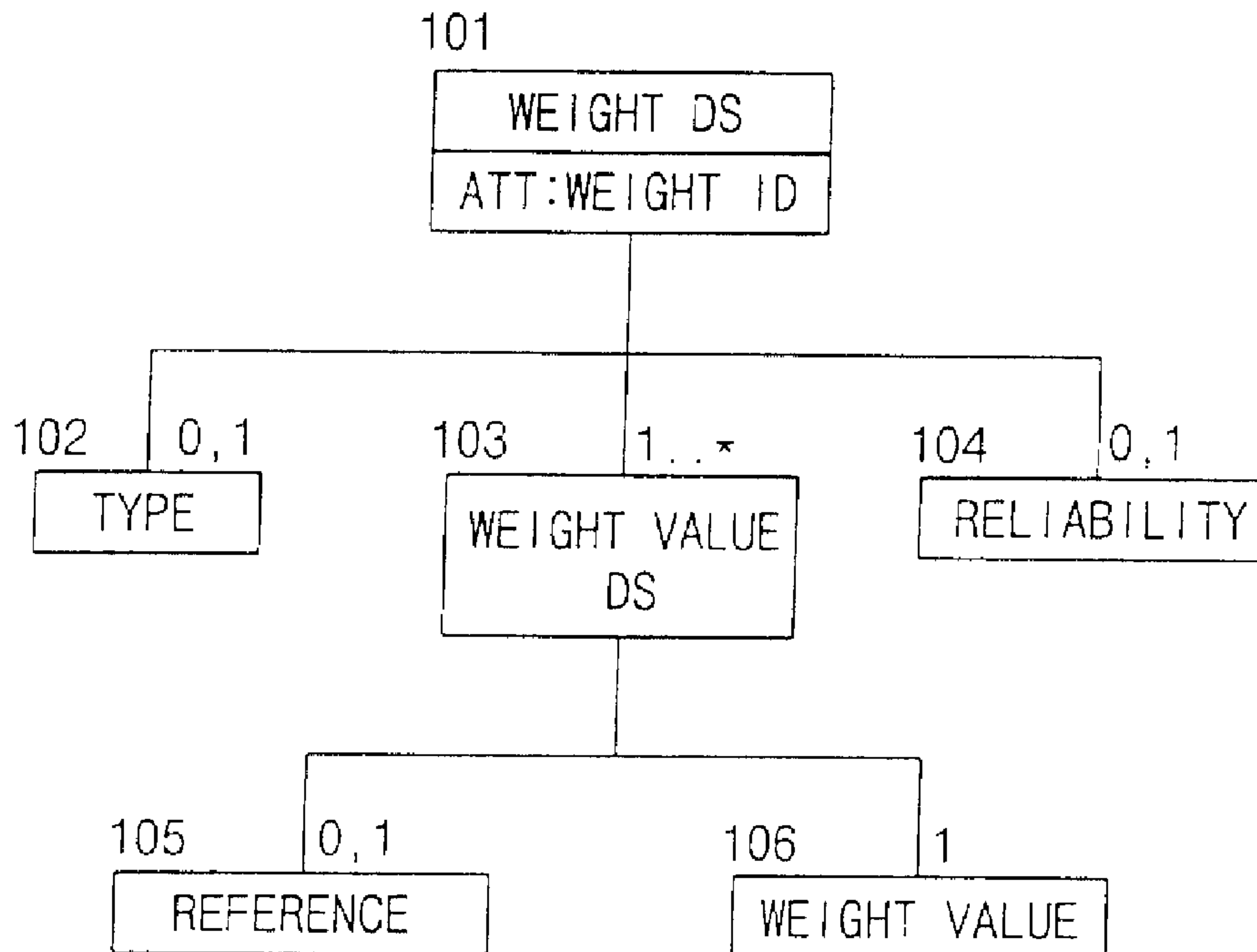

(22) Date de dépôt/Filing Date: 2000/10/16
 (41) Mise à la disp. pub./Open to Public Insp.: 2001/04/19
 (45) Date de délivrance/Issue Date: 2006/04/04
 (30) Priorité/Priority: 1999/10/19 (45202/1999) KR

(51) Cl.Int./Int.Cl. *G06F 17/30* (2006.01)
 (72) Inventeurs/Inventors:
 LEE, JIN SOO, KR;
 SONG, JUNG MIN, KR
 (73) Propriétaire/Owner:
 LG ELECTRONICS INC., KR
 (74) Agent: FETHERSTONHAUGH & CO.

(54) Titre : PLAN DE DESCRIPTION MULTIMEDIA COMPRENANT DES DONNEES DE POIDS ET METHODE D'AFFICHAGE D'ELEMENTS MULTIMEDIA
 (54) Title: MULTIMEDIA DESCRIPTION SCHEME HAVING WEIGHT INFORMATION AND METHOD FOR DISPLAYING MULTIMEDIA



(57) **Abrégé/Abstract:**

The present invention relates to a multimedia indexing using a weight description scheme. More specifically, the present invention relates to a weight description scheme (hereinafter, "weight DS") and a multimedia indexing method using the weight description scheme which is capable of increasing the performance of multimedia indexing and browsing by effectively describing weight information on multimedia items. The present invention provides a method for generating a multimedia description scheme for enabling effective multimedia indexing and browsing by incorporating a weight description scheme consisting of a weight type, weight value, and its reliability, so that each description scheme representing content information of multimedia describes effective weight information.

**MULTIMEDIA DESCRIPTION SCHEME HAVING WEIGHT INFORMATION
AND METHOD OF DISPLAYING MULTIMEDIA**

ABSTRACT OF THE DISCLOSURE

5

The present invention relates to a multimedia indexing using a weight description scheme. More specifically, the present invention relates to a weight description scheme (hereinafter, "weight DS") and a multimedia indexing method using the weight description scheme which is capable of increasing the performance of multimedia indexing and browsing by effectively describing weight information on multimedia items. The present invention provides a method for generating a multimedia description scheme for enabling effective multimedia indexing and browsing by incorporating a weight description scheme consisting of a weight type, weight value, and its reliability, so that each description scheme representing content information of multimedia describes effective weight information.

10

15

MULTIMEDIA DESCRIPTION SCHEME HAVING WEIGHT INFORMATION AND METHOD OF DISPLAYING MULTIMEDIA

BACKGROUND OF THE INVENTION

5

1. Field of the Invention

The present invention relates to a multimedia indexing using a weight description scheme. More specifically, the present invention relates to a weight description scheme (hereinafter, "weight DS") and a multimedia indexing method using the same.

10

2. Description of the Background Art

For content-based image indexing, various feature descriptors of the image, such as a color histogram, partial section colors, etc. are used. However, since a main feature descriptor for identifying an image varies according to a type of the image, various techniques have been provided to adapt weight information on the feature descriptor of the image.

15

As a technique for adapting weight information corresponding to the feature of an image in a content-based image indexing system according to the conventional art, there is a technique for preparing a window to input weight information at a user interface, so that the user sets weight information on a feature descriptor during indexing.

20

However, such a method is problematic in that it is difficult for a general user to set a weight on a feature descriptor corresponding to the image.

25

As another technique for describing weight information for content-based image indexing according to the conventional art, a method for setting weight information on a feature descriptor using user relevance feedback is employed.

In this method, the user firstly performs indexing once in the present state, then marks whether or not an image is similar to which the user searches for in the list according to the result of the indexing, and then

30

provides feedback to a indexing system, thus making the system automatically set or update weight information using the feedback.

This method is advantageous in that the system itself automatically sets weight information on a feature descriptor by using the user's feedback.

5 The above-described techniques according to the conventional art provide examples of a weighting scheme adapted to a technique for a certain type of multimedia, such as an image.

10 However, since demands for content-based indexing and browsing of more complicated multimedia are increasing, there is a need for a weighting scheme for integrated multimedia indexing and browsing in order to meet these demands.

SUMMARY OF THE INVENTION

15 Accordingly, the present invention may enable effective multimedia indexing and browsing by providing an integrated multimedia structure and an efficient weight description scheme.

20 In accordance with one aspect of the invention, there is provided a method of indexing multimedia content, comprising assigning, for each of a plurality of items of multimedia content, a weight type that indicates the type of a weight measure, a weight value for the assigned weight type, and a reliability that indicates a confidence in the correctness that the assigned weight value is accurate and generating an index of the plurality of items of multimedia content based on at least one of the assigned weight type, weight
25 value and reliability.

In one embodiment one object can have a plurality of weight values as its weight type varies.

The weight value may be described in a n-dimensional vector, if the order of weighting targets is previously defined.

30 The weight value may be described as a set of pairs of a reference for a weighting target and a weight value, if the order of weighting values is not previously defined.

In accordance with another aspect of the invention, there is provided a method of providing a multimedia description scheme (DS), comprising describing weight information on segments or segment relations. The method involves incorporating a segment DS and a segment relational graph DS and adding more than one weight DS.

When the segment DS describes a hierarchical segment structure including another child segment DS, one weight DS may describe weight information on all segments included in the hierarchical segment structure, and a plurality of weight DSs can be described in units of child segments of one segment included in the hierarchical segment structure.

When a multimedia content DS has a segment relational graph DS comprising more than one segment relation DS and more than one segment node DS, the segment relational graph DS may describe weight information on segment relations or segment nodes by adding more than one weight DS, and the segment node DS may describe weight information on segments by adding more than one weight DS.

In accordance with another aspect of the invention, there is provided a method of providing a multimedia description scheme (DS), comprising describing weight information on objects, weight information on events, or weight information on event/object relational graphs. The method involves incorporating a plurality of event information, a plurality of object information, and a plurality of event/object relational graph DSs and adding more than one weight DS.

When the event DS or object DS describes a hierarchical object DS or event DS by including another child object DS or event DS, one weight DS included in the content DS may describe weight information on all objects or events described in the hierarchical object DS or event DS.

When the event DS or object DS describes a hierarchical object DS or event DS by including another child object DS or event DS, a plurality of weight DSs can be described in units of child objects (event) of one object (event) included in the hierarchical object DS or event DS.

In accordance with another aspect of the invention, there is provided a method of providing a multimedia description scheme (DS), comprising describing weight information on relations between events and objects or weight information on event nodes or object nodes by incorporating a multimedia event/object relational graph DS and more than one weight DS and describing weight information on events or objects by incorporating an event or object node DS and more than one weight DS.

In accordance with another aspect of the invention, there is provided a method of displaying a multimedia summary using a key frame transition graph using a weight description (DS), multimedia content DS and a segment relational graph DS. The method involves extracting as many key frames as desired by a user, in order of weight information on segments described in the weight DS in the multimedia content DS, extracting only relations including the key frames extracted in the segment relational graph DS and generating a key-frame transition graph using the relations.

In accordance with another aspect of the invention, there is provided a method for displaying a multimedia summary by displaying a key-frame transition graph using a weight description scheme (DS), a multimedia content DS and a segment relational graph DS. The method involves extracting segment relations in order of the level of weight information on segment relations described in the weight DS in the segment relational graph DS until a number of key frames desired by the user is reached and generating a key-frame transition graph using the extracted segment relational graphs.

In accordance with another aspect of the invention, there is provided a method for displaying moving images based on character/relation by indexing moving images based on character/relation using a multimedia content DS and an event/object relational graph, and displaying the same. The method involves arranging characters in the order of weight information on objects described by a weight DS included in the above multimedia content DS, arranging relational transitions between two characters in the order of weight information on the relations between objects described by a weight DS included in the above event/object relational graph DS and arranging key

frames of event segments satisfying the relation between the selected two characters in the order of weight information on segments described by a weight DS included in the DS.

5 The present invention may present a method of providing a weight description scheme for multimedia content, and multimedia indexing method using a weight description scheme (DS) comprising a weight information type that indicates the type of a weight measure of the multimedia content, a weight value for each weight type, and a reliability value that indicates a confidence in correctness that the weight value is accurate.

10 In addition, the present invention presents a method of providing a multimedia DS for enabling effective indexing and browsing, comprising: describing weight information on segments or weight information on segment relations by incorporating a segment DS and a segment relational graph DS, and adding more than one weight DS.

15 In addition, the present invention presents a method of providing a multimedia DS for enabling effective indexing and browsing, comprising: describing weight information on segment relations or weight information on segment nodes in such a manner that a multimedia content DS has a segment relational graph DS comprising of more than one segment relation DS and more than one segment node DS, wherein said segment relation DS further includes more than one weight DS; and describing weight information on segments in such a manner that the segment node DS further includes more than one weight DS.

25 In addition, the present invention presents a method of providing a multimedia DS for enabling effective multimedia indexing and browsing, comprising: describing weight information on objects, weight information on events, or weight information on event/object relational graphs in such a manner that a multimedia content DS includes a plurality of event information, a plurality of object information, and a plurality of event/object relational graph DSs, and said content DS further includes more than one weight DS.

30 In addition, the present invention presents a method of providing a multimedia DS for enabling effective multimedia indexing and browsing,

comprising: describing weight information on relations between events and objects or weight information on event or object nodes in such a manner that a multimedia event/object relational graph DS further includes more than one weight DS; and describing weight information on events or objects in such a manner that an event node DS or object node DS further includes more than one weight DS.

In addition, the present invention provides a method of displaying multimedia which makes it possible to perform a multimedia summary display using a multimedia DS, weight DS, and segment relational graph DS.

In addition, the present invention provides a method of displaying multimedia which makes it possible to display moving images by indexing the same by character and relation using a multimedia DS and content information, weight DS, and event/object relational graph DS.

Additional advantages and features of the invention will become more apparent from the following description.

BRIEF DESCRIPTION OF THE DRAWINGS

The present invention will become better understood with reference to the accompanying drawings, which are given only by way of illustration and thus are not limitative of the present invention, wherein:

Figures 1A and 1B are a schematic diagram and XML code listing respectively, illustrating a commonly used weight description scheme (DS), and the same in an XML format respectively according to a first embodiment of the invention;

Figure 2 is a view illustrating a segment DS;

Figures 3A and 3B are views illustrating examples of a description of weight information on segments in the segment DS of Figure 2;

Figures 4A and 4B are views illustrating a multimedia syntactic DS with a weight DS, wherein Figure 4A illustrates the syntactic DS, and Figure 4B describes the same in an XML format;

Figures 5A and 5B are views illustrating a segment relational graph DS with a weight DS, wherein Figure 5A illustrates the segment relational graph DS, and Figure 5B describes the same in an XML format;

5 Figures 6A and 6B are views illustrating a multimedia semantic DS with a weight DS, wherein Figure 6A illustrates the multimedia semantic DS, and Figure 6B describes the same in an XML format;

Figures 7A and 7B are views illustrating an event/object relational graph DS with a weight DS, wherein Figure 7A illustrates the event/object relational graph DS, and Figure 7B describes the same in an XML format;

10 Figures 8A and 8B are views illustrating a browsing in a key-frame transition graph format using the segment DS and the segment relational graph DS within the multimedia syntactic DS;

Figure 9 is a view illustrating an example of a character/relation-based moving image browser.

15

DETAILED DESCRIPTION OF THE PREFERRED EMBODIMENTS

Figures 1A and 1B illustrate a first embodiment of a weight description scheme (DS) according to in the present invention, wherein Figure 1A illustrates the weight DS, and Figure 1B describes the same in an XML format.

20

The multimedia weight DS of the present embodiments includes a weight type, weight value, and reliability so that each DS representing the information of multimedia content can effectively describe weight information.

25

As-seen from Figure 1A, a weight DS 101 includes a weight type 102, weight value 103, and reliability 104.

The weight type 102 is used to describe the criteria applied for defining a weight value. One object can have a plurality of kinds of weight information as its criteria vary.

30

For example, weight information on feature descriptors used in image indexing can be described by two kinds of weight information simultaneously described with respect to the same object, e.g., one kind includes weight

information generated by learning through the user's feedback, and the other kind includes weight information directly designated by an image generator.

At this time, these two kinds of weight information can be distinguished from each other according to their generation using the weight type 102.

5 For example, the weight type of the former one (weight information generated by learning through the user's feedback) is "relevance feedback", and the latter one (weight information directly designated by the image generator) is "manual".

10 In addition, the reliability 104 shows how reliable the weight value assigned to an object according to the weight type 103 is. In other words, it shows if the current weight information is reliable.

15 For example, if the weight type is "relevance feedback", the reliability can be assigned according to how much feedback is provided, or if the weight type is "manual", a low value or high reliability value can be assigned to indicate whether the person assigning weight information is a naïve user or expert with respect to the corresponding object.

In Figures 1A and 1B, the weight DS 103 includes a plurality of weight value DSs each comprising a reference 105 and a weight value 106.

20 Figure 2 shows an embodiment illustrating a segment DS, and Figures 3A and 3B illustrate examples of a description of weight information on segments in the segment DS of Figure 2. As shown in Figures 3A and 3B, the weight information on segments in the segment DS are described as a series of weight value DS references and weight values respectively referring to the segments.

25 In other words, with respect to each of the segment DSs 201 through 201, weight information is described as a series of weight value DS references and weight values referring to each segment DS. Figure 3A describes weight information of all the segments included in a hierarchical structure, and Figure 3B describes the weight information thereof included in
30 the hierarchical structure in units of segment group by each level.

As an example of the description of the weight information on the segments as a series of weight objects and weight values referring to each

segment as shown in Figure 3 in the segment DSs of Figure 2, segment 0 (seg0) 201 is described as a weight value DS reference (=‘seg0’) and a weight value (=0.6), and other segments are also described as a weight value DS reference and a weight value.

5 However, when the order of a plurality of weight value DS references are previously defined, weight information can be described in an n-dimensional vector consisting of only weight values, but no information on weight value DS references.

10 At this time, since each weight value can be mapped to the corresponding weight value DS reference according to the previously defined order, the weight value DS references can be omitted.

 In addition, when the weight value DS references are not previously defined, weight information can be described as a set of pairs of weight value DS references and their weight values.

15 Figures 4A and 4B are views illustrating an embodiment of a multimedia weight DS including a multimedia syntactic DS with a weight DS. Figure 4A illustrates the syntactic DS, and Figure 4B describes the same in an XML format.

20 The multimedia weight DS of the embodiment shown in Figures 4A and 4B includes a syntactic DS, which is a multimedia content DS associated with a multimedia DS, for multimedia content-based indexing and browsing. When the syntactic DS includes a segment DS representing description schemes of segments and a segment-relation graph DS defining the relation between the segments, the syntactic DS describes weight information on the segments or weight information on the relation between the segments by further including more than one weight DS.

 The syntactic DS 401 includes a weight DS 402, a plurality of segment DSs 403, and a segment-relation graph DS 404.

30 The weight DS 402 describes weight information on the segments or the segment-relation graph.

 The segment DS 403 can be constructed hierarchically as shown in Figure 2. At this time, the weight DS can be described as weight information

of all segments included in the hierarchical structure as shown in Figure 3A, or can be described as weight information thereof included in the hierarchical structure in unit of segment group by each level as shown in Figure 3B.

5 In other words, as the segment DS describes a hierarchical segment description scheme by having another child segment DS, one weight DS included in the syntactic DS can describe weight information of all segments described in the hierarchical segment DS, or each of a plurality of weight DSs can describe weight information of all segments in unit of child segment of one segment included in the hierarchical segment DS.

10 In this example, because there exist three segment groups in the hierarchical structure, the weight information of all segments are described in three weight DSs.

In this way, various forms of weight information can be described using a reference for the target of weighting.

15 Figures 5A and 5B are views illustrating an embodiment of a multimedia DS including segment relational graph DS a weight DS. Figure 5A illustrates a segment relational graph DS, and Figure 5B describes the same in an XML format.

20 The multimedia DS of the embodiment shown in Figures 5A and 5B describes the relation between segments by describing weight information on segment relations or weight information on segment nodes in such a manner that a multimedia content DS has a segment relational graph DS comprising more than one segment relation DS and more than one segment node DS, wherein said segment relation DS further includes more than one weight DS; and describing weight information on segments in such a manner that the
25 segment node DS further includes more than one weight DS.

30 The segment relational graph DS 501 includes more than one segment relation DS 502 and more than one segment node DS 504. The segment relation DS 502 includes more than one segment relation DS or segment node. The segment node DS 504 includes more than one segment, segment node DS, or segment relation DS, and further includes a reference to region 505, corresponding regions 506, segment 507, and reference to segment 508.

Using this DS, a hierarchical segment relational graph can be generated.

Here, the weight DS **503** included in the segment relational graph DS describes weight information on the relations between segments, or weight information on segment nodes, and the weight DS **509** included in the segment node DS **504** describes weight information on segments included in the relational graph.

Figures **6A** and **6B** are views illustrating an embodiment of a multimedia semantic DS with a weight DS, wherein Figure **6A** illustrates the multimedia semantic DS, and Figure **6B** describes the same in an XML format.

The multimedia DS of the embodiment shown in Figures **6A** and **6B** describes weight information on objects, weight information on events, or weight information on event/object relational graphs for enabling effective multimedia indexing and browsing in such a manner that a multimedia content DS includes a semantic DS related with multimedia content, said semantic DS comprising a plurality of event information, a plurality of object information, and a plurality of event/object relational graph DSs, wherein said semantic DS further includes more than one weight DS.

The semantic DS **601** includes a weight DS **602**, a plurality of object DSs **603**, event DS **604**, and event/object relational graph DS **605**.

The weight DS **602** describes weight information on objects, weight information on events, or weight information on event/object relational graphs.

The object DS **603**, event DS **604**, and event/object relational graph DS **605** can be described hierarchically in the same way as in the segment DS and segment relational graph DS. At this time, also, weight information can be described in unit parts of each hierarchical structure or in the entire hierarchical structure using a reference for the target of weighting.

In other words, in the multimedia DS of Figures **6A** and **6B**, as the object (or event) DS describes a hierarchical object (or event) DS by including another child object (or event) DS, one weight DS included in the semantic DS can describe weight information of all objects (or events) described in the

hierarchical object (or event) DS, or each of a plurality of weight DSs can describe weight information thereof in unit of child object (or event) of one object (or event) included in the hierarchical object(or event) structure.

5 **Figures 7A and 7B are views illustrating an embodiment comprising an event/object relational graph DS with a weight DS. Figure 7A illustrates the event/object relational graph DS, and Figure 7B describes the same in an XML format.**

10 **The multimedia DS of the present invention in Figures 7A and 7B describes weight information on event/object relations or event/object nodes in such a manner that an event/object relational graph DS further includes more than one weight DS, and describes weight information on events or objects in such a manner that an event/object node DS further includes more than one weight DS, in order to describe the relation between the objects and the events, when an event/object relation graph DS includes more than one event/object relation DS and more than one event/object node DS, wherein the event/object relation DS includes more than one event/relation graph DS or event/object node, and wherein the event/object node DS includes more than one object, event, event/object node DS, or event/object relation DS.**

15 **The basic DS in Figures 7A and 7B is similar to the segment relational graph DS described in Figures 5A and 5B.**

20 **The event/object relational graph DS 701 includes more than one event/object relation DS 702, weight DS 703, event/object node DS 704, wherein the event/object relation DS 702 includes more than one event/object relation DS or event/object node, and wherein the event/object node DS 704 includes more than one object, event, event/object node DS, or event/object relation DS. The event/object node DS 704 comprises a reference to object DS 705, object DS 706, event 707, reference to event 708, and weight DS 709.**

25 **Here, the weight DS 703 included in the event/object relational graph DS 701 describes weight information on event/object relations or weight information on event/object nodes, and the weight DS 709 included in the event/object node DS 704 describes weight information on events or objects.**

Meanwhile, as described above, when the weight information included in the multimedia content DS having a weight DS includes weight information described with respect to a specific part of the hierarchical structure, or weight information described with respect to one of many items, such as object, event, etc., it is identified by means of a weight value DS reference included in the weight DS whether it is weight information on a certain part, or weight information on a certain item.

Using the above-described multimedia content DS, a method for browsing and indexing multimedia having weight information, and method for displaying multimedia will now be described.

First, when using the multimedia DS and segment relational graph DS including a weight DS, a key-frame transition graph type browsing as a user-dependent key frame-based summarization application will be described.

In displaying a key frame transition graph using the above-described weight DS, multimedia content DS, and segment relational graph DS, the method for displaying a multimedia summary using the multimedia DS of the present invention includes the steps of extracting key frames as much as a user wants in the order of weight information on segments described in the weight DS in the multimedia content DS, extracting only relations including the key frames extracted in the segment relational graph DS, and generating a key-frame transition graph using the same.

In addition, in displaying a key-frame transition graph using the above-described weight DS, multimedia content DS, and segment relational graph DS, the method for displaying a multimedia summary including the multimedia DS of the present invention includes the steps of extracting segment relations in the order of the level of weight information on segment relations described in the weight DS in the segment relational graph DS until the number of key frames that the user wants is reached, and generating a key-frame transition graph using the extracted segment relational graphs.

Hereinafter, the method for displaying a multimedia summary will be described with reference to Figures 8A and 8B.

A segment is defined as a predetermined portion of a moving image on the basis of a time axis. The moving image is comprised of continuous frames. Assuming that the moving image is comprised of 30 frames per second, a segment having a size of two seconds will have 60 continuous frames. Thus, if the time interval of the segment is 0, it means one frame. Therefore, the segment DS may describe one frame.

By this characteristic, a hierarchical key-frame structure can be described using a segment DS in the multimedia content DS, and a key-frame relational graph can be described using a segment relational graph structure. In particular, a key-frame relation means the relation of temporal order between key frames, a temporal transition graph can be described.

In other words, using the segment DS and segment relational graph DS in the multimedia content DS, key-frame transition graph type browsing as shown in Figures 8A and 8B is made possible.

At this time, the user may want to adjust the number of nodes of the key-frame transition graph, because the complexity of the key-frame transition graph can be difficult to understand.

That is, by means of the same DS, a transition graph using five key frames (frame 0 ~ frame 4) as in Figure 8A, or a transition graph using 10 frames (frame 0, frame 0.1, frame 1, frame 1.1, frame 2, frame 2.1, frame 3, frame 3.1, frame 3.2, frame 4) as in Figure 8B can be requested.

When such a request is made, a key-frame transition graph can be generated by means of key frames as desired in order of weight information level, by using the weight DS included in the DS.

In the same way, when the user designates the approximate number of key frames, a key frame transition graph can be generated by extracting relations using as many key frames as the user wants using the weight DS included in the segment relational graph DS in order of weight information level, and using the same.

At this time, since the extraction is done in order of level of weight information on key-frame transition rather than simply key frames, advantageously a key frame transition graph more effectively reflect the

overall flow of content. However, it is disadvantageous in that the number of frames that the user wants cannot be accurately reflected.

5 Next, a character/relation-based moving image browser using the multimedia semantic DS and event/object relational graph DS including a weight DS will be described.

10 In indexing moving images based on character/relation using a multimedia content DS such as the above-mentioned weight DS and event/object relational graph and displaying the same, a method for displaying moving images based on character/relation may be characterized in that: characters are arranged in order of weight information on objects described by a weight DS included in the above multimedia content DS, relational transitions between two characters are arranged in the order of weight information on the relations between objects described by a weight DS included in the above event/object relational graph DS, and key frames of event segments satisfying the relation between the selected two characters are arranged in the order of weight information on segments described by a weight DS included in the DS.

15 The method for displaying moving images based on character/relation will now be described with reference to Figures 9A and 9B.

20 Generally, since the contents of a moving image is displayed based on the relation between main characters, a method for indexing and browsing moving images based on the relation between characters can be usefully utilized.

25 Such a utilization is made possible using objects (characters) and a event/objects relational graph DS included in the multimedia content DS.

A basic user interface of such a browser is illustrated in Figure 9.

30 In Figure 9, a character screen 901 arranges characters appearing in the contents of moving images, and a character/relation screen 902 arranges characters related to the characters selected in the character screen 901 and at the same time describes changes in the relation between the selected two characters.

A main scene screen **903** arranges key frames representing an event segment satisfying the specific relation between these characters.

At this time, the order of arranging the characters arranged in the character screen **901** is set by the weight DS included in the content DS.

5 That is, the characters can be arranged in the order of priority using weight information on the objects.

In addition, the order of displaying the relations between the characters described in the character/relation screen **902** can be determined using the weight DS included in the event/object relational graph DS.

10 Finally, the order of key frames satisfying the selected relation is determined using the weight DS included in the content DS describing weight information on segments.

15 As described above, in a structure for multimedia content-based indexing and browsing, the present invention enables higher-performance indexing and browsing by describing effective weight information on each content DS. In addition, the present invention provides a weight DS corresponding to a complex multimedia content DS in various ways, for thereby preparing a multimedia standard for multimedia indexing and browsing using weight information.

20 As the present invention may be embodied in several forms without departing from the spirit or essential characteristics thereof, it should also be understood that the above-described embodiments are not limited by any of the details of the foregoing description, unless otherwise specified, but rather should be construed broadly within its spirit and scope as defined in the
25 appended claims, and therefore all changes and modifications that fall within the meets and bounds of the claims, or equivalences of such meets and bounds are therefore intended to be embraced by the appended claims.

THE EMBODIMENTS OF THE INVENTION IN WHICH AN EXCLUSIVE PROPERTY OR PRIVILEGE IS CLAIMED ARE DEFINED AS FOLLOWS:

1. A method of indexing multimedia content, comprising:

5

assigning, for each of a plurality of items of multimedia content,

a weight type that indicates the type of a weight measure,

10

a weight value for the assigned weight type, and

a reliability that indicates a confidence in the correctness that the assigned weight value is accurate; and

15

generating an index of the plurality of items of multimedia content based on at least one of the assigned weight type, weight value and reliability.

2. The method of claim 1, wherein one object can have a plurality of weight values as its weight type varies.

20

3. The method of claim 1, wherein the weight value is described in a n-dimensional vector, if the order of weighting targets is previously defined.

25

4. The method of claim 1, wherein the weight value is described as a set of pairs of a reference for weighting target and a weight value, if the order of weighting values is not previously defined.

30

5. A method of providing a multimedia description scheme (DS), comprising:

describing weight information on segments or segment relations,
comprising:

5 incorporating a segment DS and a segment relational graph DS;
and

adding more than one weight DS.

10 6. The method of claim 5, wherein, when the segment DS describes a
hierarchical segment structure including another child segment DS,
one weight DS describes weight information on all segments included
in the hierarchical segment structure, wherein a plurality of weight DSs
can be described in units of child segments of one segment included in
the hierarchical segment structure.

15

20 7. The method of claim 5, wherein when a multimedia content DS has a
segment relational graph DS comprising of more than one segment
relation DS and more than one segment node DS, the segment
relational graph DS describes weight information on segment relations
or segment nodes by adding more than one weight DS, and the
segment node DS describes weight information on segments by adding
more than one weight DS.

25 8. A method of providing a multimedia description scheme (DS),
comprising:

25

describing weight information on objects, weight information on
events, or weight information on event/object relational graphs,
comprising:

30

incorporating a plurality of event information, a plurality of object information, and a plurality of event/object relational graph DSs; and

5 adding more than one weight DS.

9. The method of claim 8, wherein, when the event DS or object DS describes a hierarchical object DS or event DS by including another child object DS or event DS, one weight DS included in the content DS describes weight information on all objects or events described in the hierarchical object DS or event DS.

10. The method of claim 8, wherein, when the event DS or object DS describes a hierarchical object DS or event DS by including another child object DS or event DS, a plurality of weight DSs can be described in unit of child object (event) of one object (event) included in the hierarchical object DS or event DS.

11. A method of providing a multimedia description scheme (DS), comprising:

describing weight information on relations between events and objects or weight information on event nodes or object nodes by incorporating a multimedia event/object relational graph DS and more than one weight DS; and

describing weight information on events or objects by incorporating an event or object node DS and more than one weight DS.

- 12.** A method of displaying a multimedia summary using a key frame transition graph using a weight description (DS), multimedia content DS and a segment relational graph DS, the method comprising:

5 extracting as many key frames as desired by a user, in order of weight information on segments described in the weight DS in the multimedia content DS;

10 extracting only relations including the key frames extracted in the segment relational graph DS; and

 generating a key-frame transition graph using the relations.

- 13.** A method for displaying a multimedia summary by displaying a key-frame transition graph using a weight description scheme (DS), a multimedia content DS and a segment relational graph DS, the method comprising:

15 extracting segment relations in order of the level of weight information on segment relations described in the weight DS in the segment relational graph DS until a number of key frames desired by the user is reached; and

20 generating a key-frame transition graph using the extracted segment relational graphs.

- 14.** A method for displaying moving images based on character/relation by indexing moving images based on character/relation using a multimedia content DS and an event/object relational graph, and displaying the same, the method comprising:

30

arranging characters in the order of weight information on objects described by a weight DS included in the above multimedia content DS;

5 arranging relational transitions between two characters in the order of weight information on the relations between objects described by a weight DS included in the above event/object relational graph DS; and

10 arranging key frames of event segments satisfying the relation between the selected two characters in the order of weight information on segments described by a weight DS included in the DS.

FIG. 1A

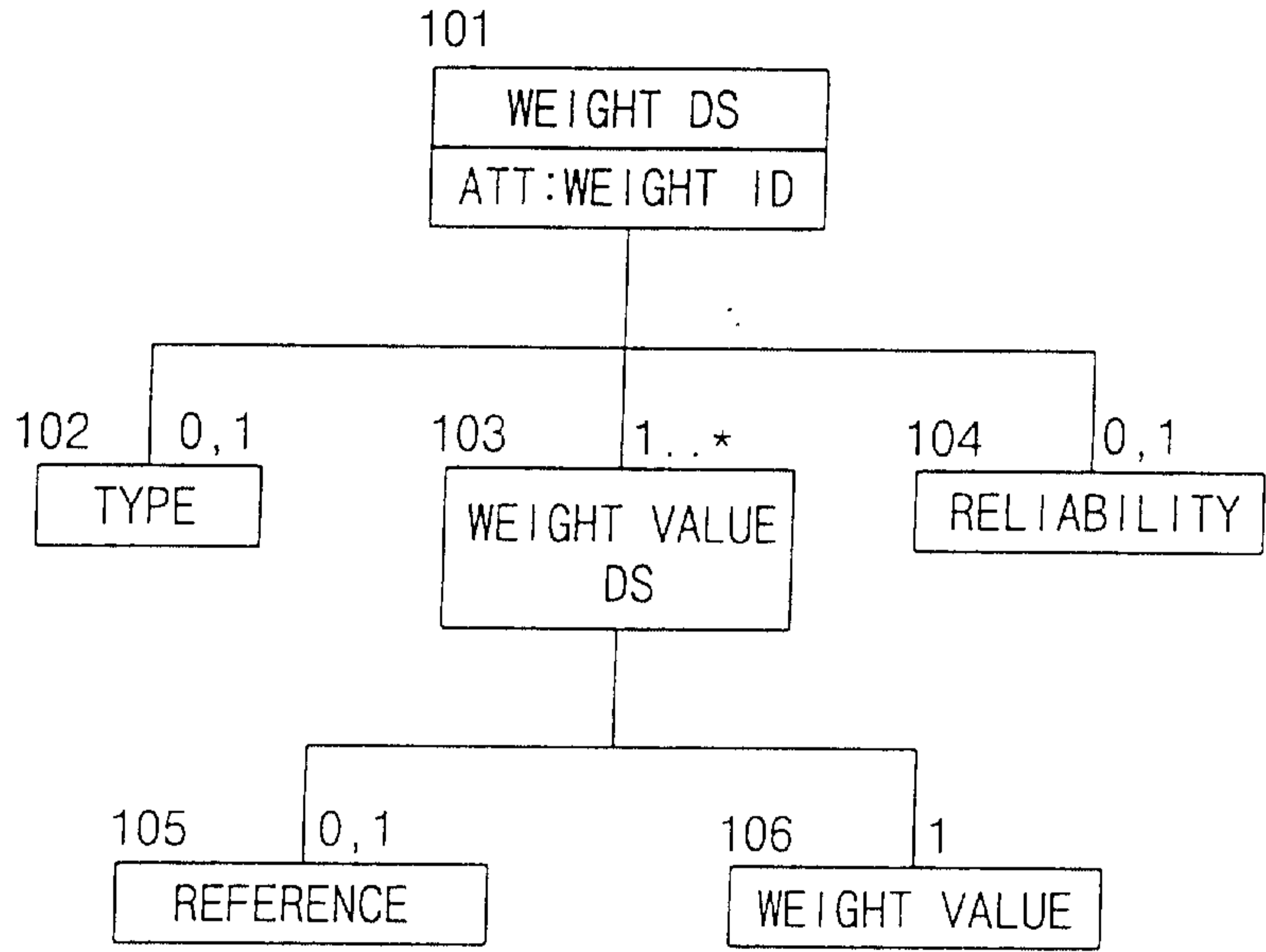

FIG. 1B

```

<!--#####_!>
<!--_!>
<!--_!>
<DescType name="Reference">
  <attrDecl name="idref" required="true">
    <datatypeRef name="IDREF"/> </attrDecl>
  <empty/>
</DescType>
<DSType name="WeightValueDS">
  <attrDecl name="value" required="true"><datatypeRef name="real"/></attrDecl>
  .. <DescTypeRef name="Reference"/>
</DSType>
<DSType name="WeightDS">
  <attrDecl name="ID"><datatypeRef name="ID"/> </attrDecl>
  <attrDecl name="TYPE"><datatypeRef name="string"/> </attrDecl>
  <attrDecl name="reliability"><datatypeRef name="real"/> </attrDecl>
  <DSTypeRef name="WeightValueDS" minOccurs="1" maxOccurs="*" />
</DSType>

```

FIG. 2

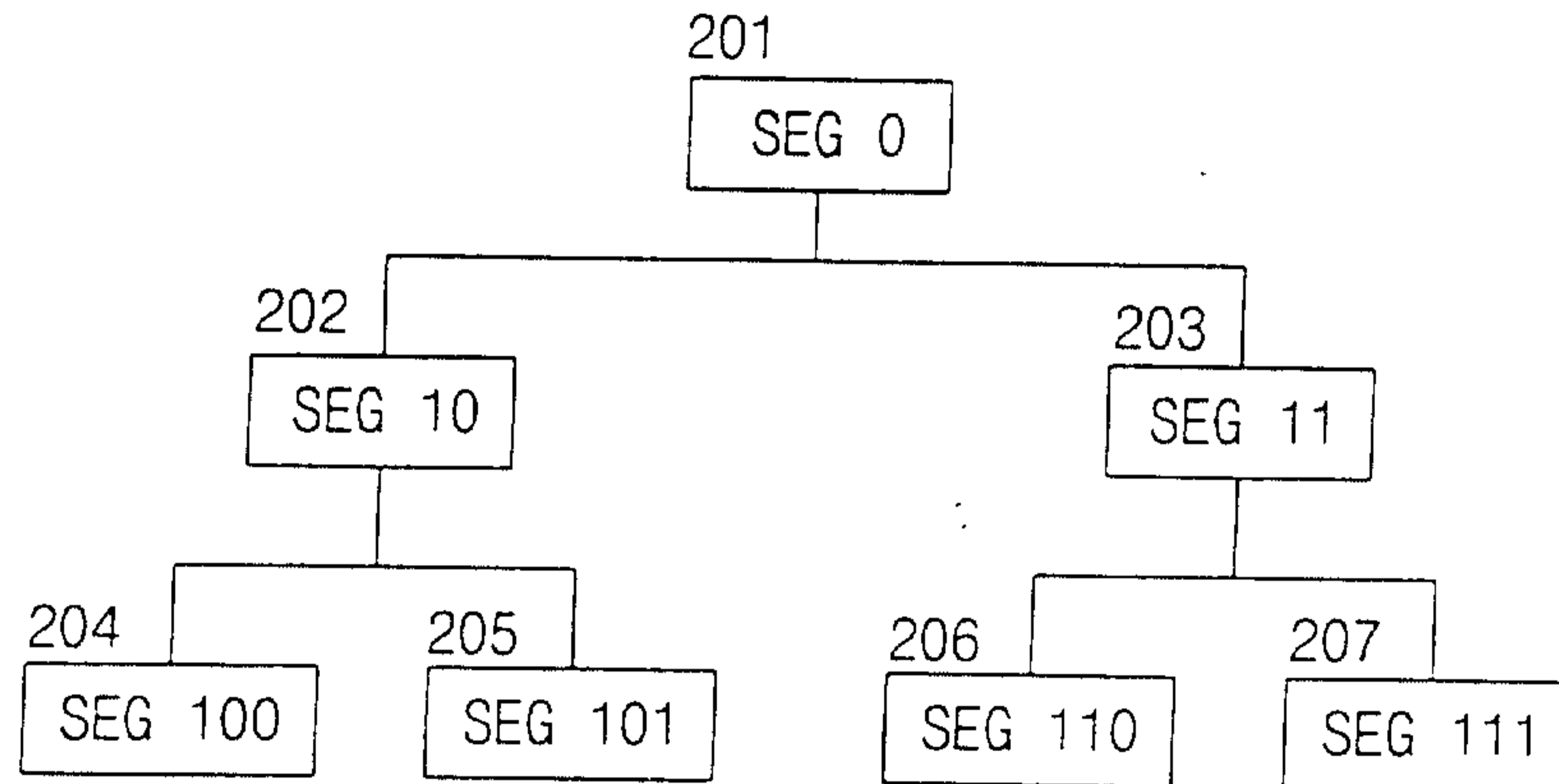

FIG. 3A

```

<SyntacticStructureDS id="#1"href="http://www.temp.com">
  <WeightDS id="segment_weight0" type="manual" reliability="1.0">
    <WeightValueDS Reference="seg0" value="0.6" />
    <WeightValueDS Reference="seg10" value="0.7" />
    <WeightValueDS Reference="seg11" value="0.3" />
    <WeightValueDS Reference="seg100" value="0.8" />
    <WeightValueDS Reference="seg101" value="0.3" />
    <WeightValueDS Reference="seg110" value="0.2" />
    <WeightValueDS Reference="seg111" value="0.5" />
  </WeightDS>
</SyntacticStructureDS>
  
```

FIG. 3B

```

<SyntacticStructureDS id="#1"href="http://www.temp.com">
  <WeightDS id="weight_seg0" type="manual" reliability="1.0">
    <WeightValueDS Reference="seg10" value="0.6" />
    <WeightValueDS Reference="seg11" value="0.4" />
  </WeightDS>
  <WeightDS id="weight_seg10" type="manual" reliability="1.0">
    <WeightValueDS Reference="seg100" value="0.3" />
    <WeightValueDS Reference="seg101" value="0.7" />
  </WeightDS>
  <WeightDS id="weight_seg11" type="manual" reliability="1.0">
    <WeightValueDS Reference="seg110" value="0.3" />
    <WeightValueDS Reference="seg111" value="0.7" />
  </WeightDS>
</SyntacticStructureDS>
  
```

FIG. 4A

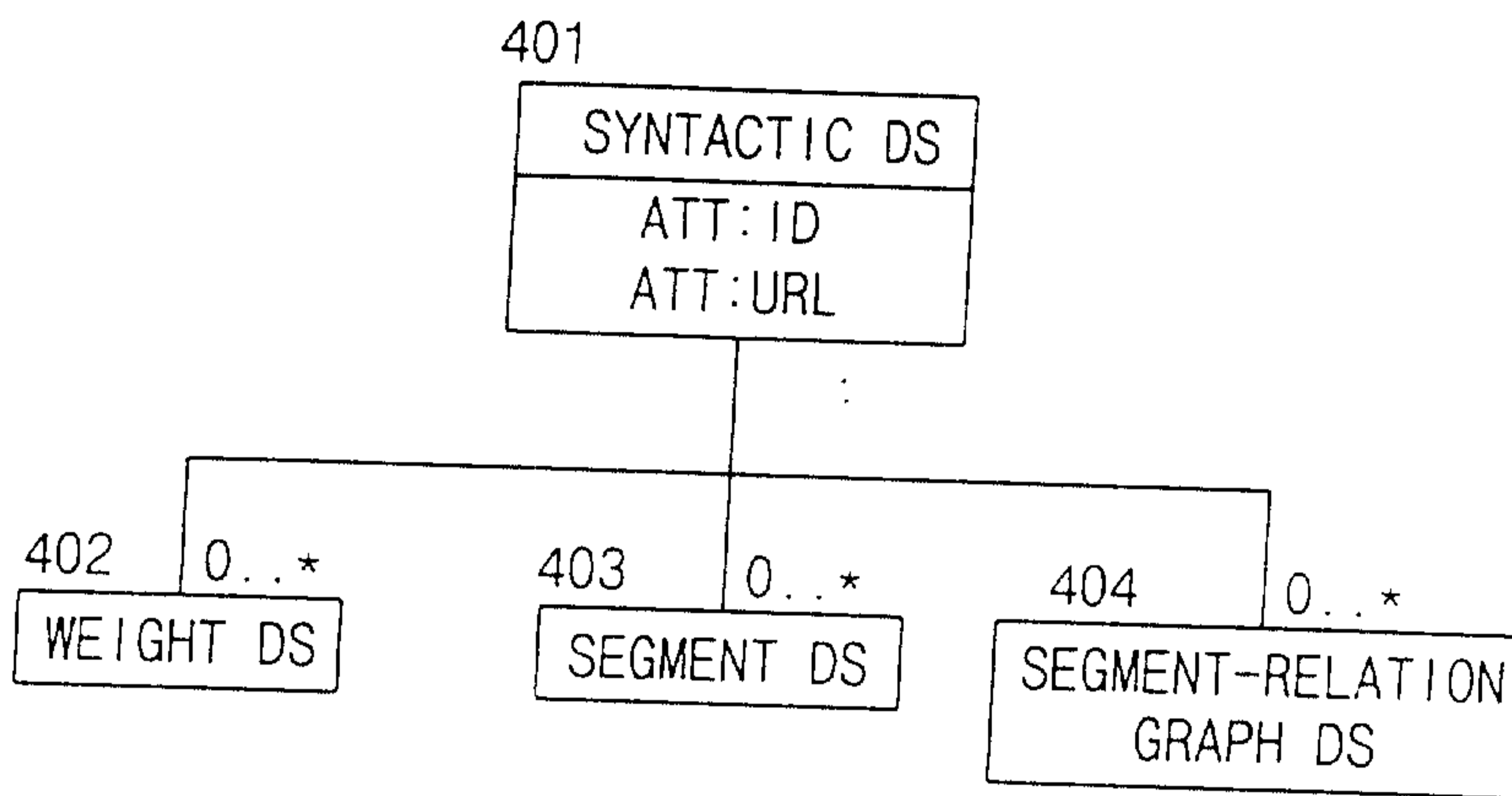

FIG. 4B

```

<!--#####_!>
<!--Definition of SyntacticDS with WeightDS_!>
<!--#####_!>
<DSType name="SyntacticDS"model="refinable">
  <attrDecl name="ID"><datatypeRef name="ID"/> </attrDecl>
  <attrDecl name="href"><datatypeRef name="uri"/> </attrDecl>
  <DSTypeRef name="WeightDS" minOccur="0" maxOccur="*" />
  <DSTypeRef name="SegmentDS" minOccur="0" maxOccur="*" />
  <DSTypeRef name="Segment-Relation-Graph" minOccur="0" maxOccur="*" />
</DSType>
    
```

FIG. 5A

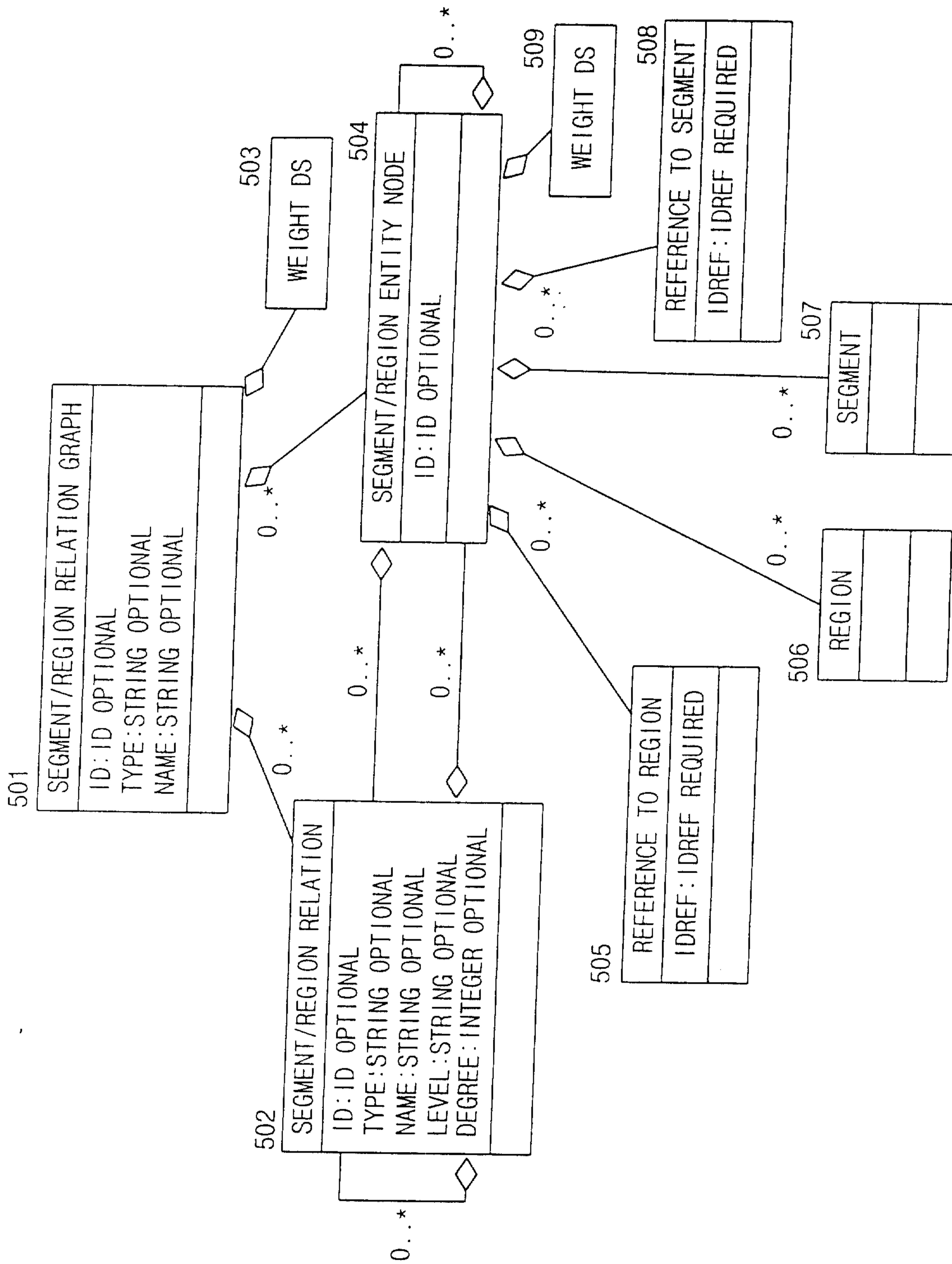

FIG. 5B

```

<!--#####_>
<!--Definition of SegmentRelationGraphDS with WeightDS _>
<!--#####_>
<DSType name="Segment-Entity-Node">
  <subDSOf name="Entity-Node/">
    <DSType name="WeightDS" minOccur="0" maxOccur="*" />
    <sequence minOccur="1" maxOccur="*">
      <choice minOccur="0" maxOccur="*">
        <DescTypeRef name="Reference-to-Segment" />
        <DSTypeRef name="Segment" />
        <DSTypeRef name="Segment-Entity-Node" />
      </choice>
      <DSTypeRef name="Segment-Relation" minOccur="0" maxOccur="*" />
    </sequence>
  </DSType>
  <DSTypeRef name="Segment-Relation">
    <subDSOf name="Relation/">
      <choice minOccur="1" maxOccur="*">
        <DSTypeRef name="Segment-Relation" />
        <DSTypeRef name="Segment-Entity-Node" />
      </choice>
    </DSType>
  <DSTypeRef name="Segment-Relation-Graph">
    <subDSOf name="Relation-Graph/">
      <DSTypeRef name="WeightDS" minOccur="0" maxOccur="*" />
      <choice minOccur="1" maxOccur="*">
        <DSTypeRef name="Segment-Relation" />
        <DSTypeRef name="Segment-Entity-Node" />
      </choice>
    </DSType>
  </DSType>

```

FIG. 6A

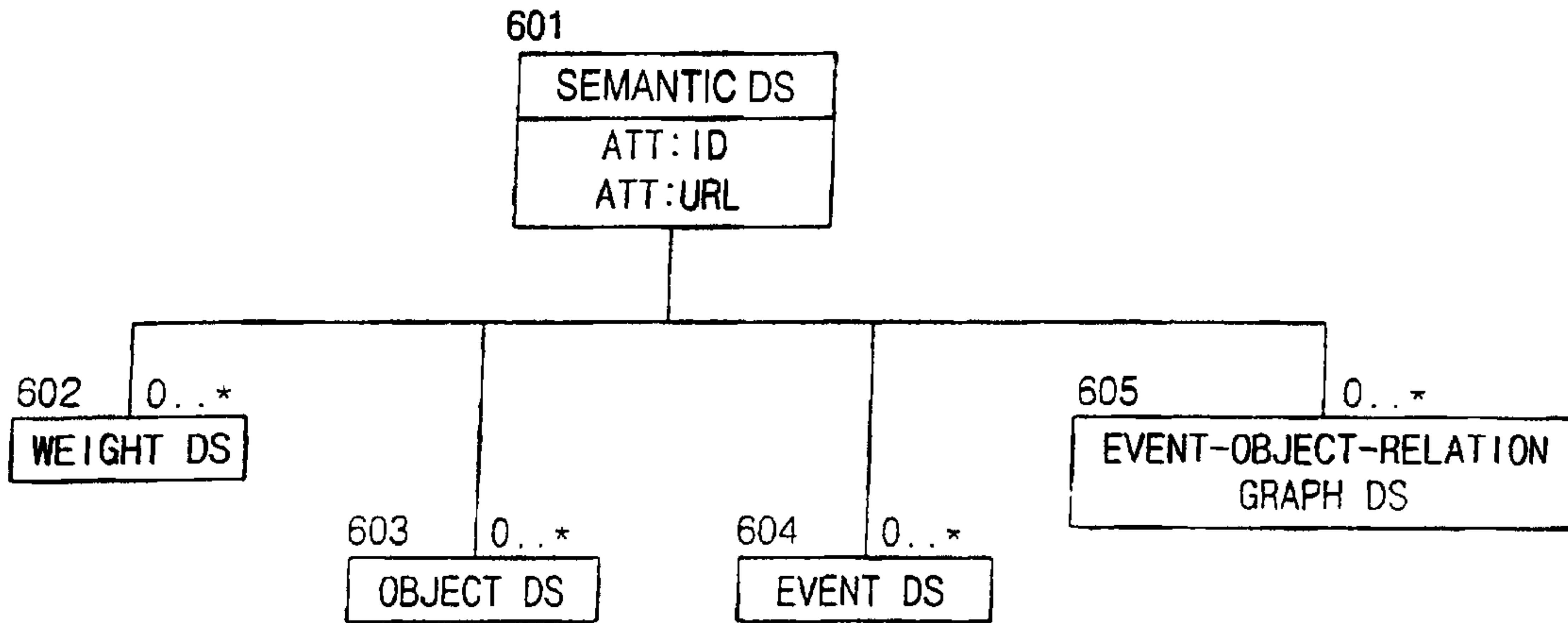

FIG. 6B

```

<!--#####--!>
<!--Definition of Semantic DS with Weight DS--!>
<!--#####--!>
<DSType name="SemanticDS" model="refinable">
  <DSType name="WeightDS" minOccurs="0" maxOccurs="*" />
  <DSType name="EventDS" minOccurs="0" maxOccurs="*" />
  <DSType name="ObjectDS" minOccurs="0" maxOccurs="*" />
  <DSType name="Event/RegionRelationGraphDS" minOccurs="0" maxOccurs="*" />
</DSType>
  
```

FIG. 7A

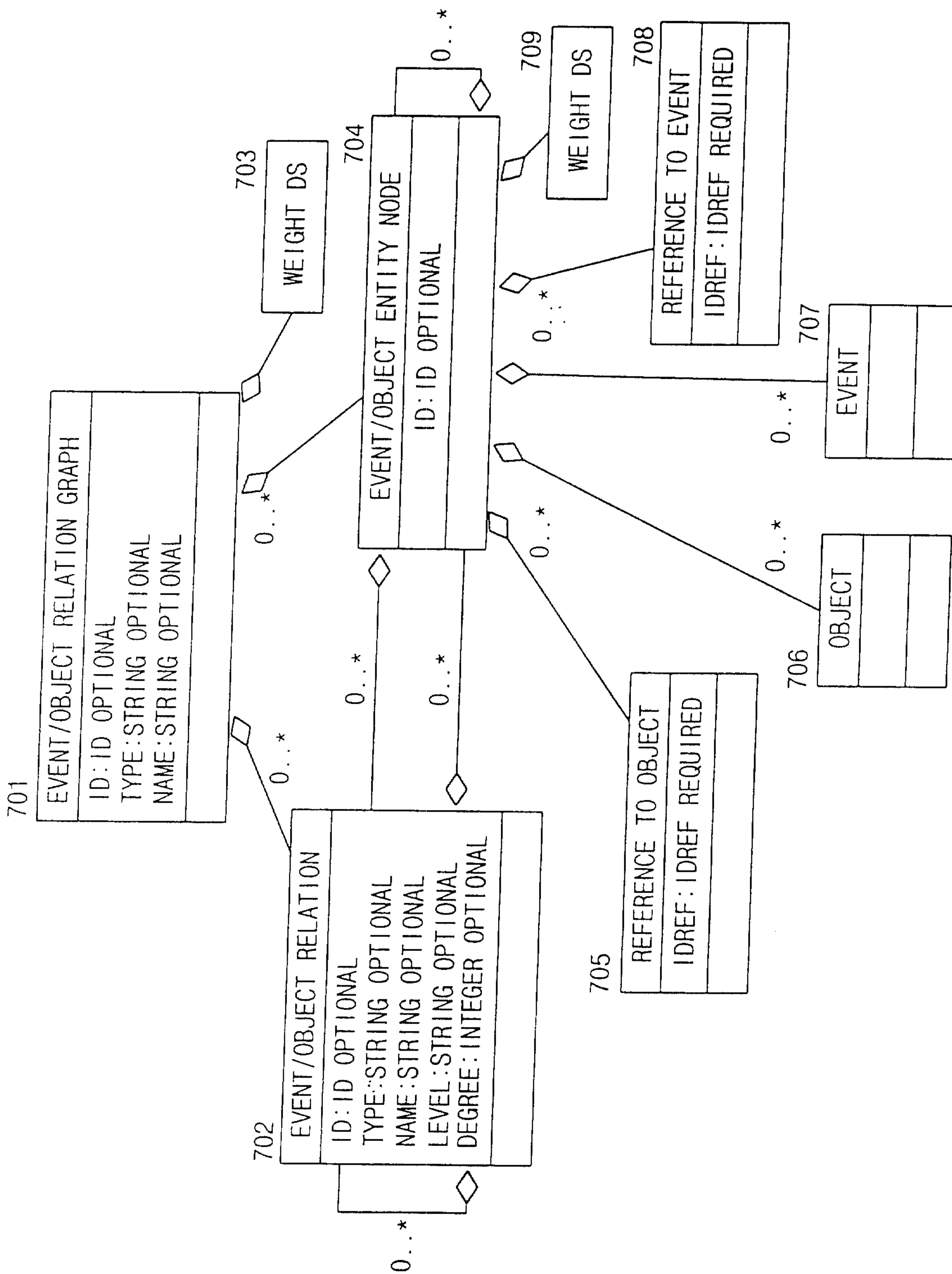

FIG. 7B

```

<!--#####_>
<!--_Definition of EventObjectRelationGraphDS with Weight DS_>
<!--#####_>

<DSType name="Event-Object-Entity-Node">
  <subDSOf name="Entity-Node/">
    <DSType name="WeightDS" minOccur="0" maxOccur="*" />
    <sequence minOccur="1" maxOccur="*">
      <choice minOccur="0" maxOccur="*">
        <DescTypeRef name="Reference-to-Event" />
        <DescTypeRef name="Reference-to-Object" />
        <DSTypeRef name="Event" />
        <DSTypeRef name="Object" />
        <DSTypeRef name="Event-Object-Entity-Node" />
      </choice>
      <DSTypeRef name="Event-Object-Relation" minOccur="0" maxOccur="*" />
    </sequence>
  </DSType>

<DSTypeRef name="Event-Object-Relation">
  <subDSOf name="Relation/">
    <choice minOccur="1" maxOccur="*">
      <DSTypeRef name="Event-Object-Relation" />
      <DSTypeRef name="Event-Object-Entity-Node" />
    </choice>
  </DSType>

<DSTypeRef name="Event-Object-Relation-Graph">
  <subDSOf name="Relation-Graph/">
    <DSTypeRef name="WeightDS" minOccur="0" maxOccur="*" />
    <choice minOccur="1" maxOccur="*">
      <DSTypeRef name="Event-Object-Relation" />
      <DSTypeRef name="Event-Object-Entity-Node" />
    </choice>
  </DSType>

```

FIG. 8A

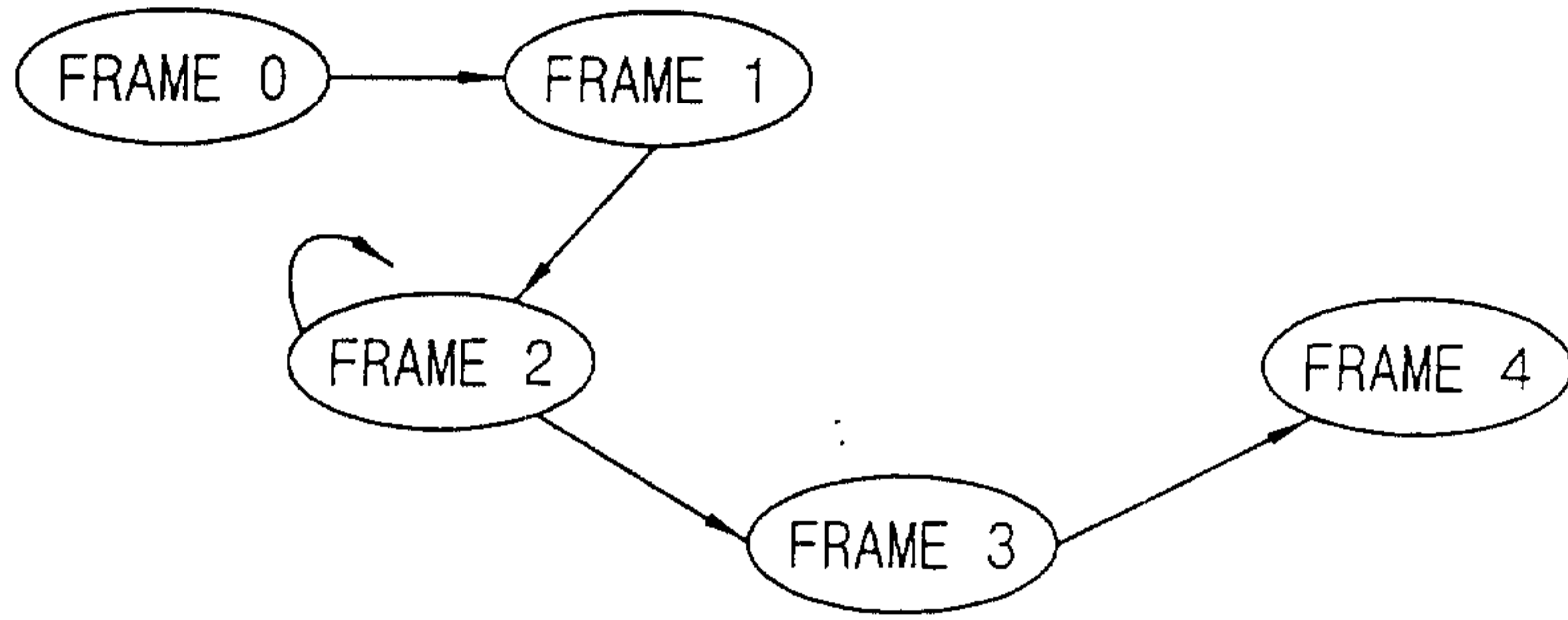

FIG. 8B

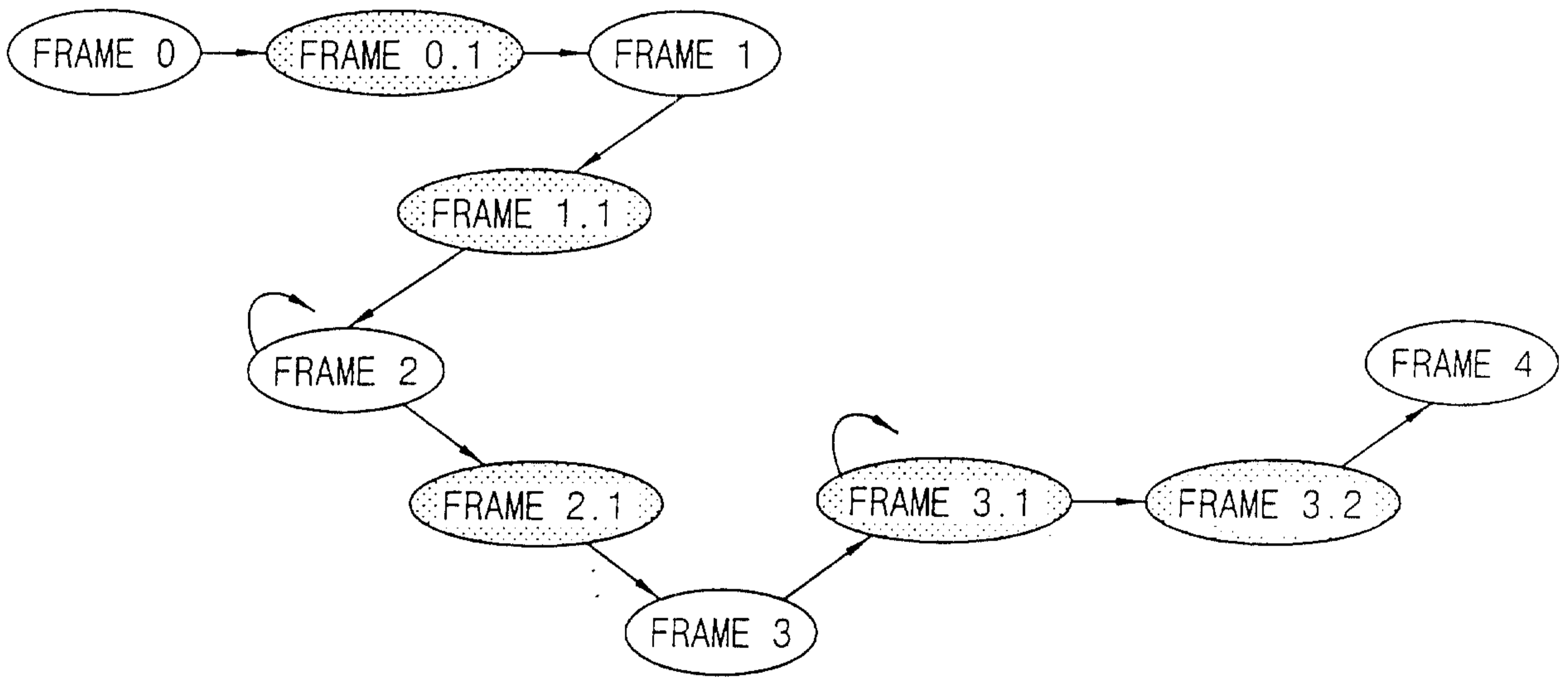

FIG. 9

