



US 20200054073A1

(19) **United States**

(12) **Patent Application Publication**
QIU

(10) **Pub. No.: US 2020/0054073 A1**

(43) **Pub. Date: Feb. 20, 2020**

(54) **ATOMIZER AND ELECTRONIC CIGARETTE**

(52) **U.S. Cl.**

(71) Applicant: **JOYETECH EUROPE HOLDING GMBH**, Zug (CH)

CPC *A24F 47/008* (2013.01); *A24B 15/167* (2016.11)

(72) Inventor: **WEIHUA QIU**, Changzhou City, Jiangsu Province (CN)

(57) **ABSTRACT**

(21) Appl. No.: **16/346,536**

(22) PCT Filed: **Sep. 29, 2017**

(86) PCT No.: **PCT/CN2017/104180**

§ 371 (c)(1),

(2) Date: **Apr. 30, 2019**

(30) **Foreign Application Priority Data**

Oct. 31, 2016 (CN) 201610967447.5

Publication Classification

(51) **Int. Cl.**

A24F 47/00 (2006.01)

An atomizer includes a liquid storage assembly and a top cover assembly. The liquid storage assembly includes a liquid storage tube, a connecting seat fixed at one end of the liquid storage tube, and an operation ring movably disposed on the connecting seat. The operation ring is provided with resisting portions. The top cover assembly includes a top cover detachably connected to the connecting seat. The top cover is provided with teeth corresponding to the resisting portions. When the operation ring is moved to cause the resisting portions and the teeth to be mutually engaged/disengaged, a detachable connection between the top cover and the connecting seat is locked/unlocked. The atomizer is difficult to be disassembled by simple operation, and therefore has a children protection function.

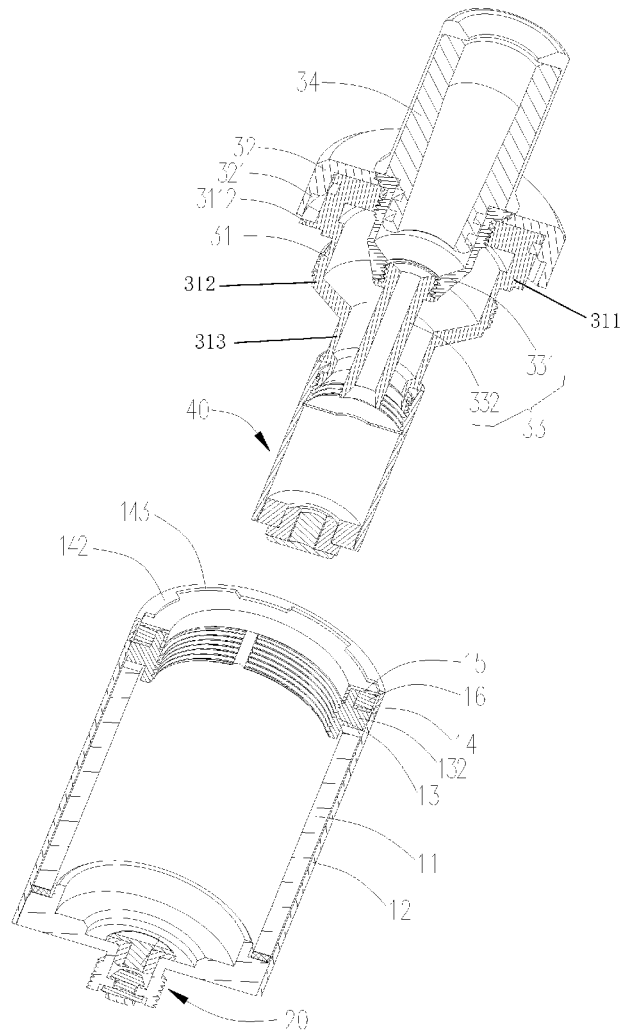

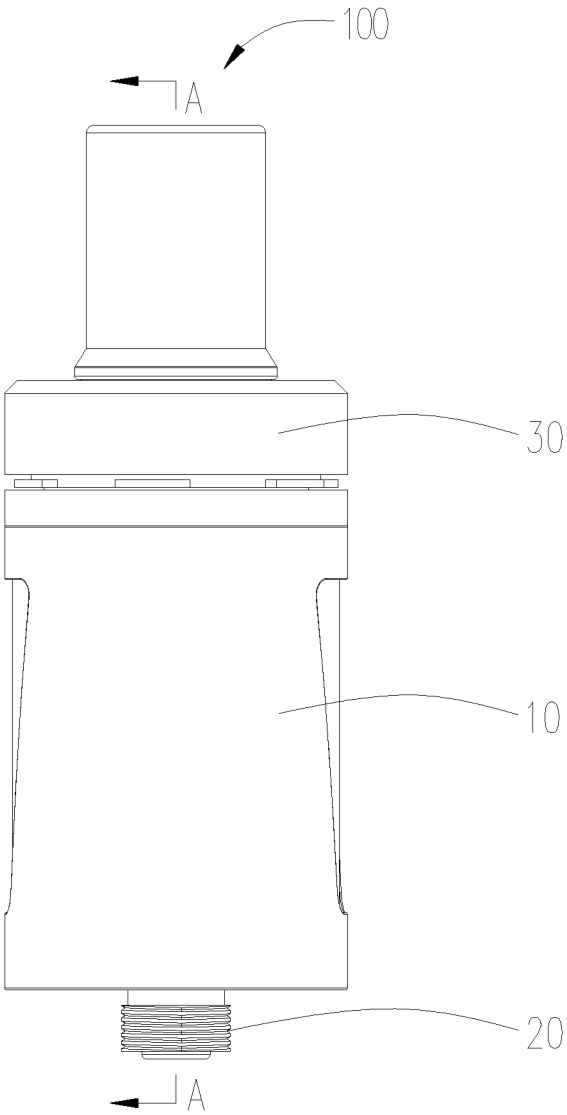

FIG. 1

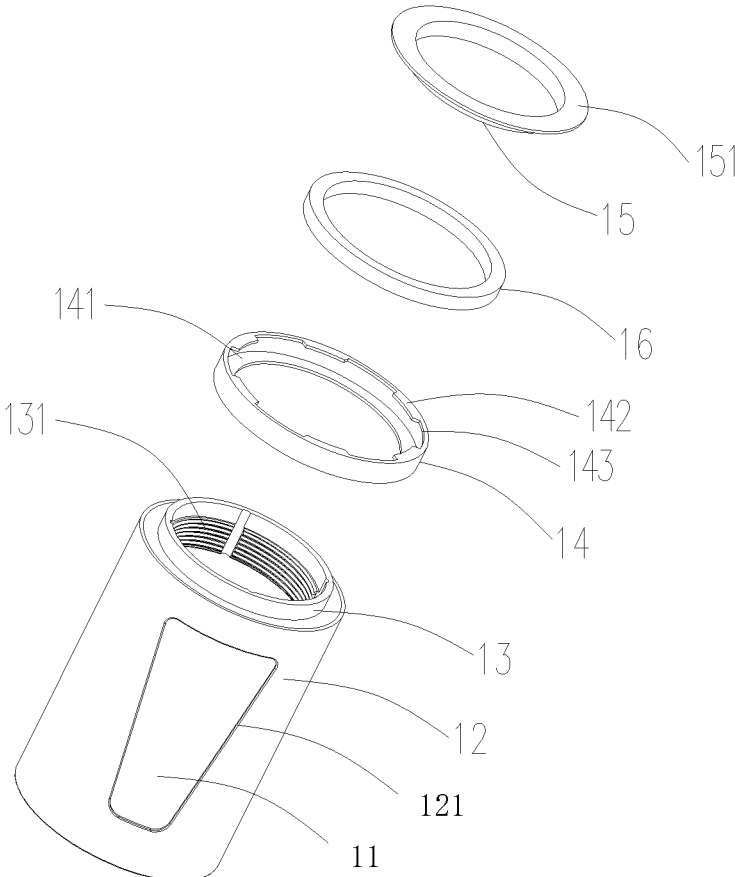

FIG. 2

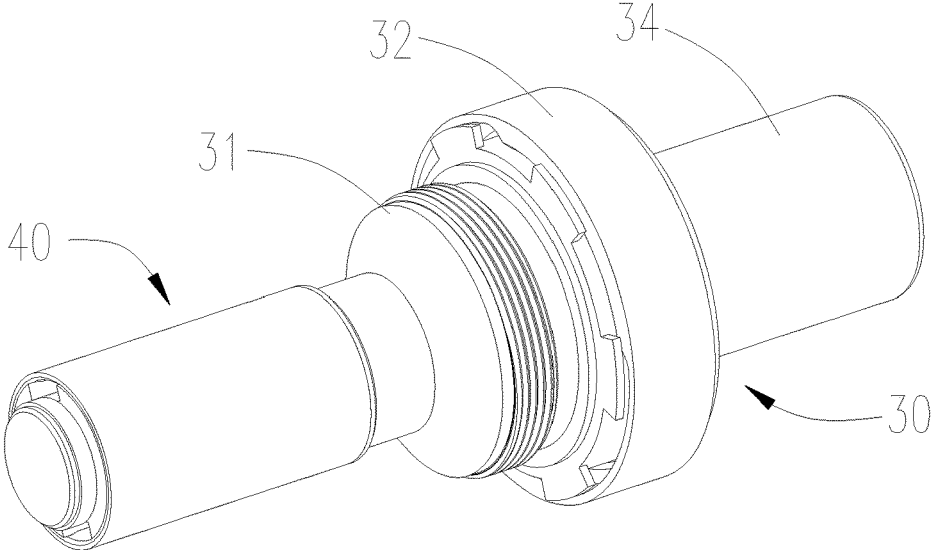

FIG. 3

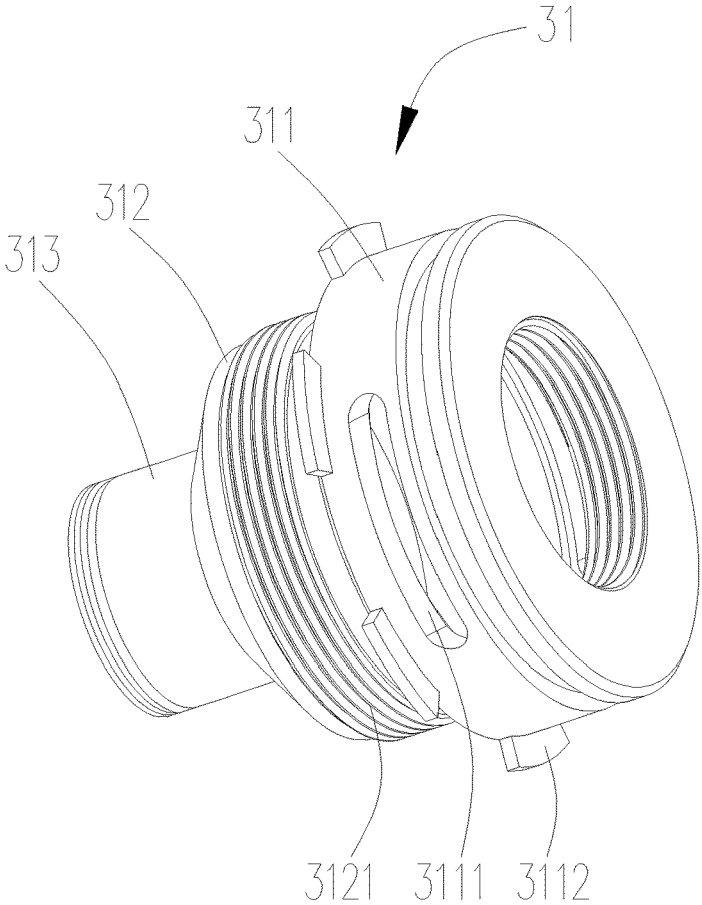

FIG. 4

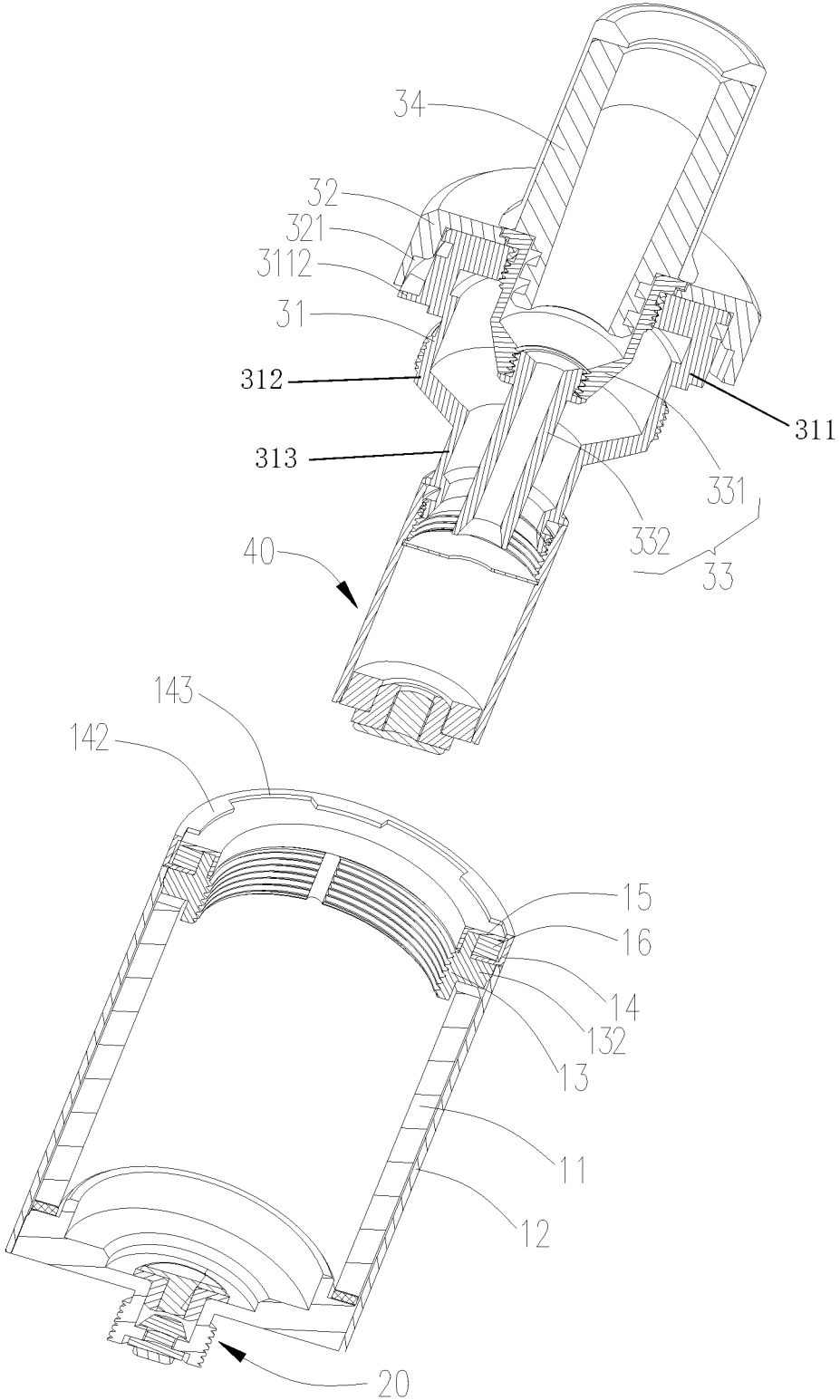

FIG. 5

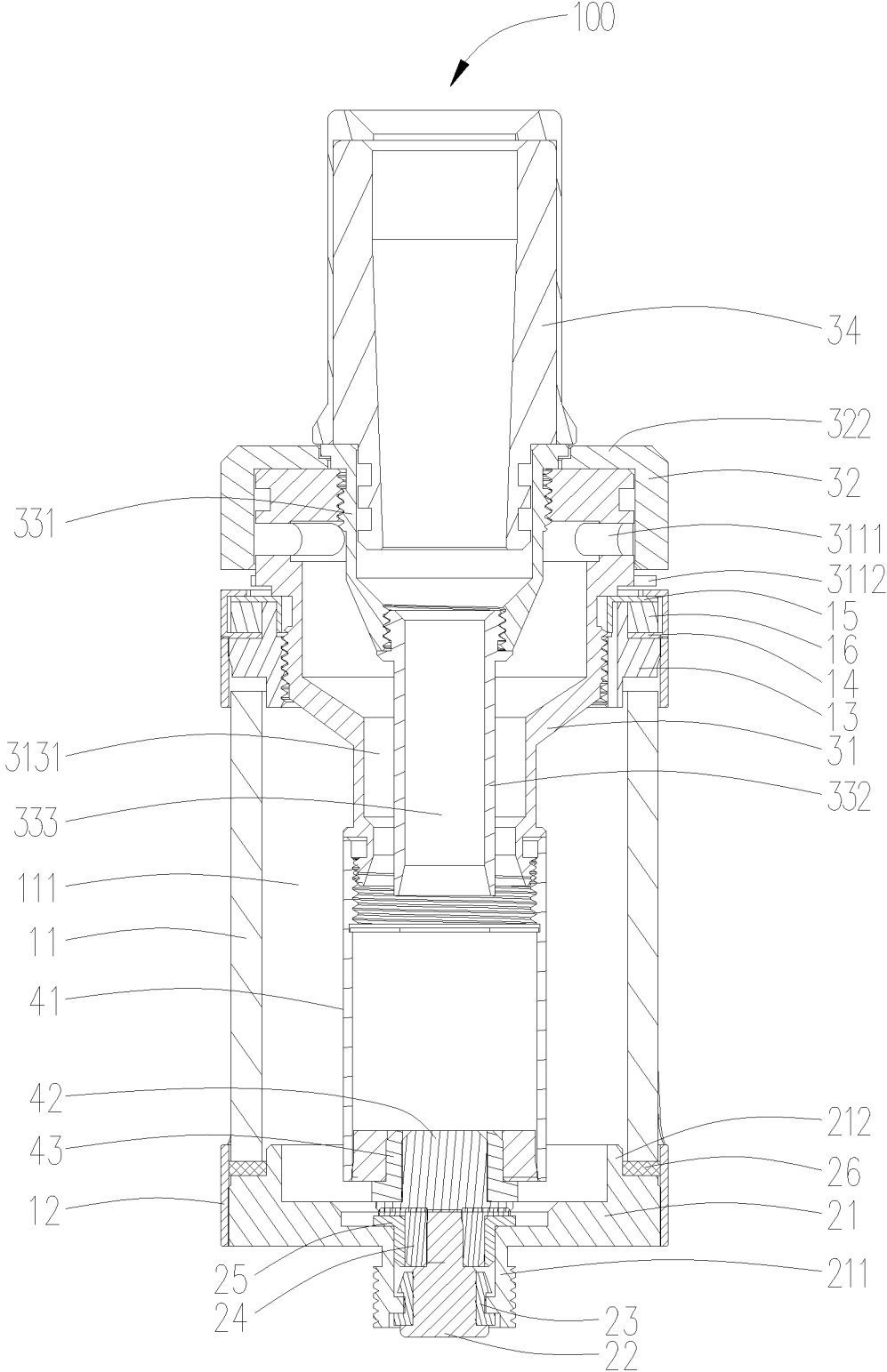

FIG. 6

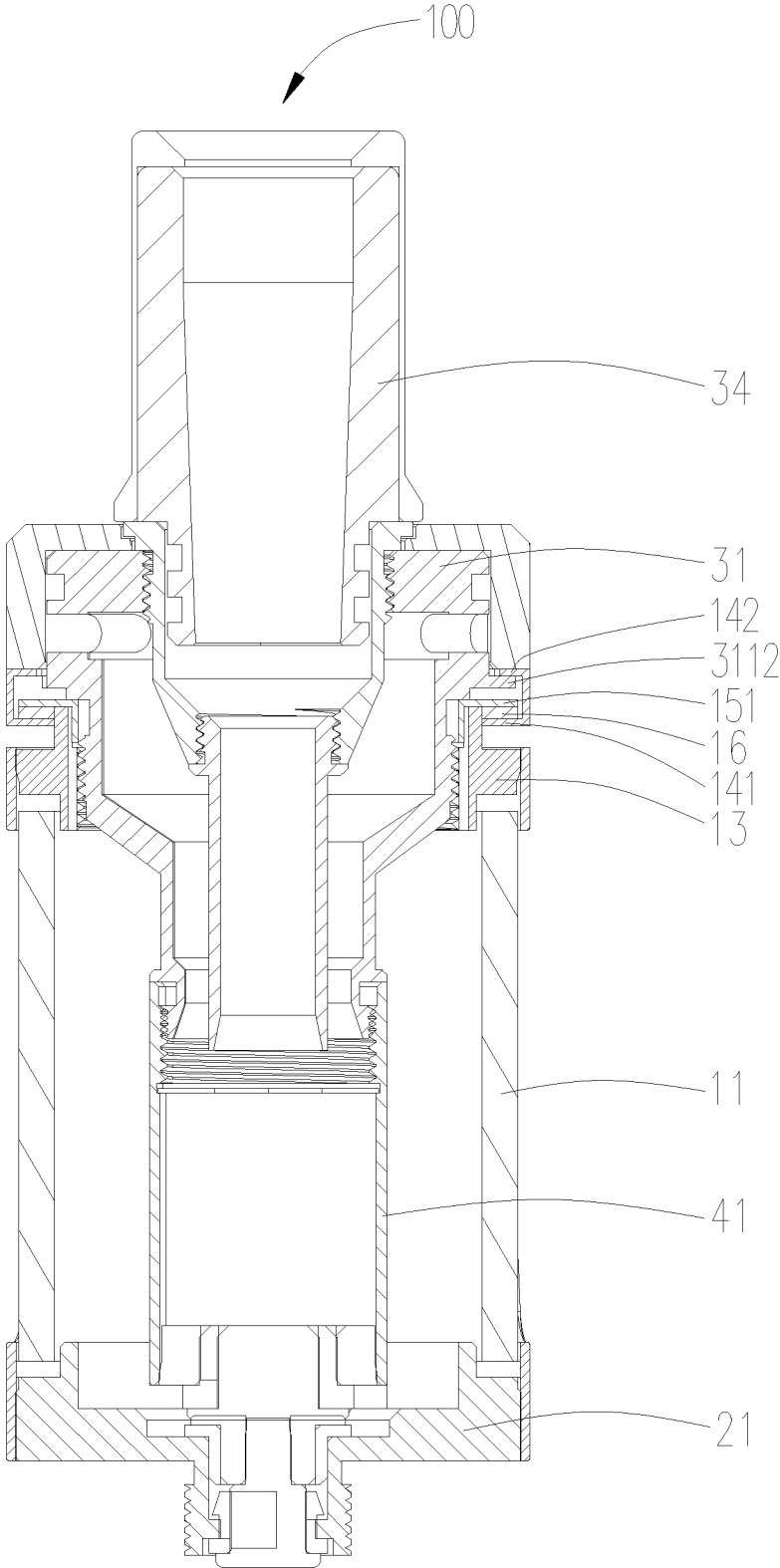

FIG. 7

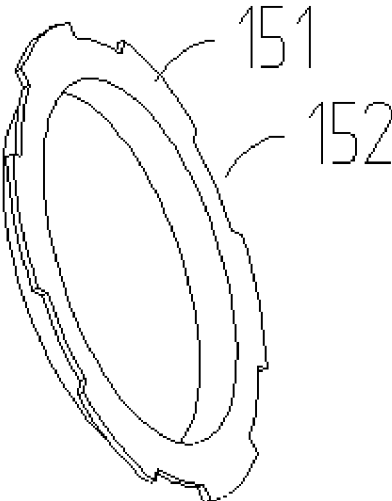

FIG. 8

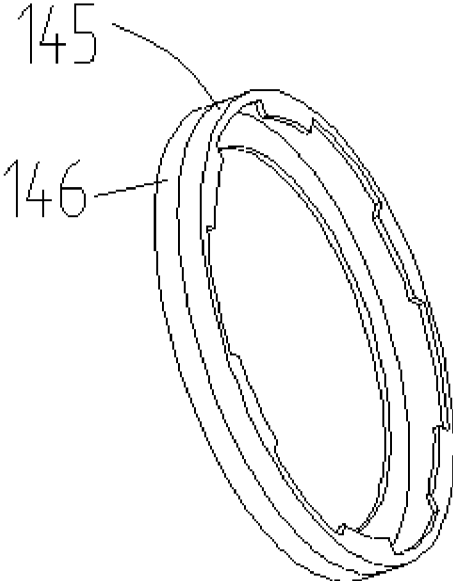

FIG. 9

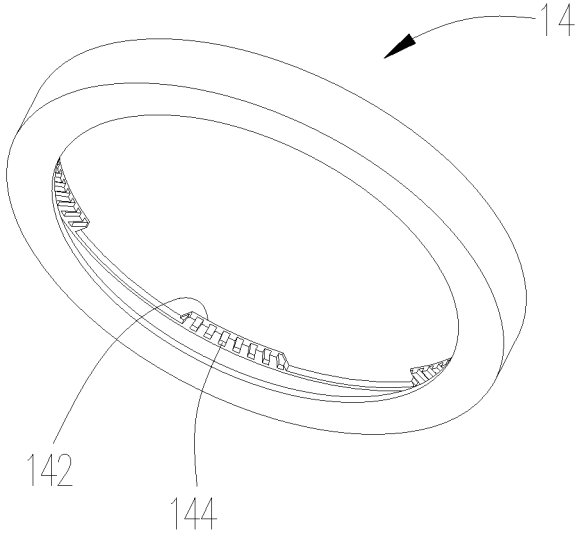

FIG. 10

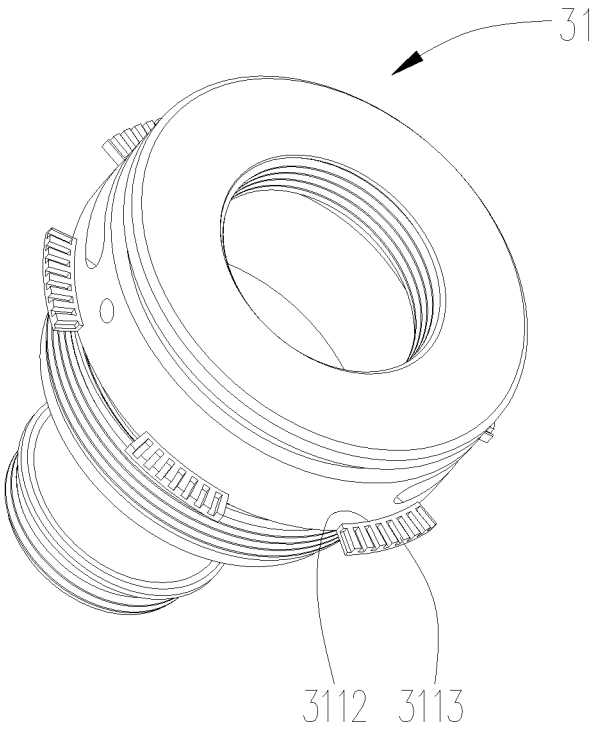

FIG. 11

ATOMIZER AND ELECTRONIC CIGARETTE

TECHNICAL FIELD

[0001] The present disclosure relates to the technical field of electronic cigarettes, and in particular, to an atomizer and an electronic cigarette having the same.

BACKGROUND

[0002] The existing electronic cigarette includes an atomizer and a power supply device, wherein the atomizer is provided with a heating member and a liquid storage assembly for storing cigarette liquid, and the cigarette liquid in the liquid storage assembly is atomized into smoke for the user to inhale when it is heated by the heating member under the electric driving action of the power source device.

[0003] A top cover assembly is disposed above the liquid storage assembly to seal the cigarette liquid. However, the liquid storage assembly and the top cover assembly are mostly detachably connected by a screw connection, a snap connection or a magnetic connection, and the structure is relatively simple. The children can separate the two assemblies by only a single operation such as rotating or drawing, and then may contact or ingest the cigarette liquid, thereby posing a safety hazard to the children, and the safety protection effect is not good.

SUMMARY

[0004] In view of the above, it is necessary to provide an atomizer and an electronic cigarette having the same with child protection function to prevent children from easily opening the atomizer to contact or ingest the cigarette liquid.

[0005] The technical solution adopted by the present disclosure to solve the above problem is: An atomizer includes a liquid storage assembly and a top cover assembly. The liquid storage assembly includes a liquid storage tube, a connecting seat fixed at one end of the liquid storage tube, and an operation ring movably disposed on the connecting seat. The operation ring is provided with resisting portions. The top cover assembly includes a top cover detachably connected to the connecting seat. The top cover is provided with teeth corresponding to the resisting portions. When the operation ring is moved to cause the resisting portions and the teeth to be mutually engaged/disengaged, a detachable connection between the top cover and the connecting seat is locked/unlocked.

[0006] Further, the operation ring is rotatably sleeved on the connecting seat, and the operation ring is capable of sliding along an axial direction of the connecting seat. The resisting portions is formed by extending radially inward along a radial direction of the operation ring from one end of the operation ring near the top cover, grooves are defined in the resisting portions corresponding to the teeth, and the grooves are able to pass through the teeth correspondingly along an axial direction of the operation ring.

[0007] Further, the atomizer further includes a press ring disposed at an upper end of the connecting seat. A lower abutting portion is formed by extending radially inward along the radial direction of the operation ring from one end of the operation ring away from the top cover. An upper abutting portion is formed by extending radially outward along a radial direction of the press ring from one end of the press ring near the top cover. An outer peripheral surface of the connecting seat has a flange extending outward along a

radial direction of the connecting seat. The lower abutting portion is located between a lower surface of the upper abutting portion and an upper surface of the flange.

[0008] Further, an outer surface of the connecting seat defines an annular groove along a circumferential direction of the connecting seat. A lower abutting portion is formed by extending radially inward along the radial direction of the operation ring from one end of the operation ring away from the top cover. The lower abutting portion is located between upper and lower groove walls of the annular groove.

[0009] Further, the operation ring is made of an elastic material. Optionally, the atomizer further includes an elastic member disposed between the operation ring and the press ring. One end of the elastic member elastically abuts against the lower abutting portion, and the other end of the elastic member elastically abuts against the upper abutting portion.

[0010] Further, for the two mutually engaged surfaces between the resisting portions of the operation ring and the teeth of the top cover, one of the surfaces is provided with protrusions, and the other one of the surfaces is provided with recesses matching with the protrusions.

[0011] Further, an internal thread is provided on an inner wall of the connecting seat, and an external thread matching with the internal thread is provided on an outer wall of the top cover below the teeth. Optionally, a locking groove is provided on an inner peripheral surface of the connecting seat, and a clamp matching with the locking groove is provided on an outer peripheral surface of the top cover below the teeth. Optionally, the connecting seat and the portion of the top cover in contact with the connecting seat are each made of a magnetic material.

[0012] Further, the top cover assembly further includes an adjusting member rotatably sleeved on the top cover. At least one air inlet hole is defined in a sidewall of the top cover above the teeth. An air adjusting groove in communication with the external environment is defined in the inner sidewall of the adjusting member corresponds to each air inlet hole. The adjusting member is rotated to cause the air adjusting groove and the corresponding air inlet hole to be communicated with each other or staggered from each other.

[0013] Further, the top cover assembly further includes an air outlet pipe received in the top cover and a mouthpiece connector connected to the air outlet pipe. A space between an inner wall of the top cover and an outer wall of the air outlet pipe forms an air inlet passage communicating with the air inlet hole. An inner space of the air outlet pipe forms an air outlet passage communicating with the mouthpiece connector.

[0014] Another atomizer includes a liquid storage assembly and a top cover assembly. The liquid storage assembly includes a liquid storage tube provided with an opening and an operation ring movably disposed at the opening. The operation ring is provided with resisting portions. The top cover assembly includes a top cover detachably covering the opening. The top cover is provided with teeth corresponding to the resisting portions. When the operation ring is moved to cause the resisting portions and the teeth to be mutually engaged/disengaged, a detachable connection of the top cover is locked/unlocked.

[0015] Further, the liquid storage assembly further includes a connecting seat disposed at the opening. The operation ring is rotatably sleeved on the connecting seat, and the operation ring is capable of sliding along an axial direction of the connecting seat. The resisting portions is

formed by extending radially inward along a radial direction of the operation ring from one end of the operation ring near the top cover, grooves are defined in the resisting portions corresponding to the teeth, and the grooves are able to pass through the teeth correspondingly along an axial direction of the operation ring.

[0016] Further, the atomizer further includes a press ring disposed at an upper end of the connecting seat. A lower abutting portion is formed by extending radially inward along the radial direction of the operation ring from one end of the operation ring away from the top cover. An upper abutting portion is formed by extending radially outward along a radial direction of the press ring from one end of the press ring near the top cover. An outer peripheral surface of the connecting seat has a flange extending outward along a radial direction of the connecting seat. The lower abutting portion is located between a lower surface of the upper abutting portion and an upper surface of the flange.

[0017] Further, an outer surface of the connecting seat defines an annular groove along a circumferential direction of the connecting seat. A lower abutting portion is formed by extending radially inward along the radial direction of the operation ring from one end of the operation ring away from the top cover. The lower abutting portion is located between upper and lower groove walls of the annular groove.

[0018] Further, the operation ring is made of an elastic material.

[0019] Further, the atomizer further includes an elastic member disposed between the operation ring and the press ring. One end of the elastic member elastically abuts against the lower abutting portion, and the other end of the elastic member elastically abuts against the upper abutting portion.

[0020] Further, for the two mutually engaged surfaces between the resisting portions of the operation ring and the teeth of the top cover, one of the surfaces is provided with protrusions, and the other one of the surfaces is provided with recesses matching with the protrusions.

[0021] An electronic cigarette includes the above atomizer.

children from easily opening the atomizer to contact or ingest the cigarette liquid, to achieve a certain child protection function.

BRIEF DESCRIPTION OF THE DRAWINGS

[0023] The present disclosure will now be further described with reference to the accompanying drawings and embodiments.

[0024] FIG. 1 is a schematic structural view of an atomizer according to a first embodiment of the present disclosure;

[0025] FIG. 2 is an exploded view of the liquid storage assembly of the atomizer of FIG. 1;

[0026] FIG. 3 is a perspective view of the top cover assembly and the atomizing assembly of the atomizer of FIG. 1;

[0027] FIG. 4 is a schematic structural view of the top cover of FIG. 3;

[0028] FIG. 5 is an exploded cross-sectional view of the atomizer of FIG. 1;

[0029] FIG. 6 is a cross-sectional view of the atomizer of FIG. 1 taken along line A-A (showing the state in which the operation ring unlocks the top cover);

[0030] FIG. 7 is another cross-sectional view of the atomizer of FIG. 1 (showing the state in which the operation ring locks the top cover);

[0031] FIG. 8 is a schematic structural view of another example of the press ring shown in FIG. 2;

[0032] FIG. 9 is a schematic structural view of another example of the operation ring shown in FIG. 2;

[0033] FIG. 10 is a schematic structural view of an operation ring in an atomizer according to a second embodiment of the present disclosure;

[0034] FIG. 11 is a schematic structural view of a top cover in the atomizer of the second embodiment of the present disclosure.

[0035] The part names and their reference signs in the figures are:

atomizer 100	liquid storage assembly 10	bottom seat assembly 20
top cover assembly 30	atomizing assembly 40	liquid storage tube 11
sleeve 12	connecting seat 13	operation ring 14
press ring 15	elastic member 16	bottom seat 21
first electrode 22	first insulating member 23	electrode sleeve 24
second insulating member 25	sealing member 26	top cover 31
adjusting member 32	air outlet pipe 33	mouthpiece connector 34
atomizing head 41	second electrode 42	third insulating member 43
liquid storage chamber 111	visible window 121	internal thread 131
lower abutting portion 141	resisting portion 142	groove 143
upper abutting portion 151	connecting tube 211	sleeve portion 212
air inlet cap 311	connecting ring 312	air inlet pipe 313
air adjusting groove 321	abutment portion 322	connecting body 331
pipe body 332	air outlet passage 333	air inlet hole 3111
teeth 3112	external thread 3121	air inlet passage 3131
protrusion 144	recess 3113	flange 132
upper ring portion 145	lower ring portion 146	cutout 152

[0022] The beneficial effects of the present disclosure are: For the atomizer or the electronic cigarette of the present disclosure, before disassembly, it is needed to firstly slide the operation ring, and further rotate the operation ring in order to separate the resisting portions of the operation ring from the teeth of the top cover. The disassembly process is relatively complicated, the children are difficult to achieve by a single operation, thereby effectively preventing the

DETAILED DESCRIPTION OF PREFERRED EMBODIMENTS

[0036] The present disclosure will now be described in detail in conjunction with the drawings. These drawings are simplified schematic diagrams illustrating the basic structure of the present disclosure only in a schematic manner, and thus they show only the configuration related to the present disclosure.

First Embodiment

[0037] Referring to FIG. 1 and FIG. 3, the present disclosure provides an atomizer 100 including a liquid storage assembly 10, a bottom seat assembly 20 mounted at the lower end of the liquid storage assembly 10, a top cover assembly 30 detachably connected to the upper end of the liquid storage assembly 10, and an atomizing assembly 40 received in the liquid storage assembly 10.

[0038] Referring to FIG. 2, the liquid storage assembly 10 includes a liquid storage tube 11, a sleeve 12 sleeved outside the liquid storage tube 11, a connecting seat 13 fixedly mounted on the upper end of the liquid storage tube 11, an operation ring 14 rotatably sleeved on the connecting seat 13, a press ring 15 fixedly mounted on the upper end of the connecting seat 13, and an elastic member 16 disposed between the operation ring 14 and the press ring 15. The operation ring 14 is movable along the axial direction of the connecting seat 13.

[0039] Referring also to FIG. 6, the liquid storage tube 11 is a tubular structure having openings at upper and lower ends, and the inner space of the liquid storage tube 11 forms a liquid storage chamber 111 for storing cigarette liquid. The liquid storage tube 11 is made of transparent or translucent material, to observe the amount of the cigarette liquid in the liquid storage chamber 111. In this embodiment, the liquid storage tube 11 is made of glass.

[0040] The sleeve 12 is a tubular structure having openings at upper and lower ends, and the sleeve 12 is made of a hard material to protect the liquid storage tube 11. In this embodiment, the sleeve 12 is made of stainless steel. Further, a visible window 121 is opened on the sidewall of the sleeve 12 for precise liquid injection.

[0041] Referring to FIG. 2 and FIG. 5, the connecting seat 13 has a substantially annular structure. The middle portion of the outer peripheral surface of the connecting seat 13 has a flange 132 extending outward along the radial direction of the connecting seat 13. The lower end of the connecting seat 13 is fixedly connected to the liquid storage tube 11 by interference fit, and the lower surface of the flange 132 abuts against the upper surface of the liquid storage tube 11. The inner wall of the connecting seat 13 is provided with an internal thread 131.

[0042] The operation ring 14 has a substantially annular structure, and the lower end of the operation ring 14 extends inward along the radial direction of the operation ring 14 to form a lower abutting portion 141. The upper end of the operation ring 14 extends inward along the radial direction of the operation ring 14 to form resisting portions 142. A plurality of grooves 143 are defined between the resisting portions 142. It can be understood that there may be only one groove 143.

[0043] The press ring 15 has a substantially annular structure, and the lower end of the press ring 15 is fixedly connected to the inner surface of the connecting seat 13 by interference fit. The upper end of the press ring 15 extends outward along the radial direction of the press ring 15 to form an upper abutting portion 151.

[0044] The elastic member 16 has an annular structure, the lower end of the elastic member 16 elastically abuts against the lower abutting portion 141 of the operation ring 14, and the upper end of the elastic member 16 elastically abuts against the upper abutting portion 151 of the press ring 15. By pushing the operation ring 14 upward, the operation ring 14 compresses the elastic member 16 and slides upward. By

releasing the operation ring 14, the operation ring 14 is reset downward under the elastic force of the elastic member 16.

[0045] In one of the embodiments, the elastic member 16 is a rubber ring made of a rubber material. It can be understood that the elastic member 16 may also be a member with rigidity and elasticity, such as a spring, a thin steel sheet or the like.

[0046] When mounting, the elastic member 16 is firstly mounted on the lower abutting portion 141 of the operation ring 14, and then the operation ring 14 is sleeved outside the connecting seat 13, and the lower abutting portion 141 is supported on the upper surface of the flange 132 of the connecting seat 13. The lower end of the press ring 15 is fitted with the inner surface of the connecting seat 13 by interference, and the upper abutting portion 151 of the press ring 15 is inserted between the elastic member 16 and the resisting portions 142 of the operation ring 14. Thus, the lower surface of the upper abutting portion 151 and the upper surface of the flange 132 of the connecting seat 13 together limit the movement distance of the operation ring 14, and the operation ring 14 can be automatically reset by the elastic member 16.

[0047] It is noted that in order to facilitate the installation of the press ring 15, in one embodiment, please refer to FIG. 8, a plurality of cutouts 152 are defined in the upper abutting portion 151 of the press ring 15 for the resisting portions 142 to pass through. The elastic member 16 is firstly disposed between the resisting portions 142 and the lower abutting portion 141 of the operation ring 14. The cutouts 152 of the press ring 15 pass through the resisting portions 142, and then, the press ring 15 is rotated, so that the cutouts 152 are offset from the resisting portions 142, and the upper abutting portion 151 and the resisting portions 142 abut against with each other, thereby finishing the installation of the operation ring 14, the press ring 15 and the elastic member 16.

[0048] In another embodiment, referring to FIG. 9, the operation ring 14 is divided into an upper ring portion 145 and a lower ring portion 146. When assembling, the upper ring portion 145 and the lower ring portion 146 are firstly separated, and then the press ring 15 and the elastic member 16 are inserted into the upper ring portion 145 sequentially from the lower end of the upper ring portion 145, and thereafter, the upper end of the lower ring portion 146 is fixedly connected to the lower end of the upper ring portion 145, thereby finishing the installation of the operation ring 14, the press ring 15 and the elastic member 16. The manner in which the upper ring portion 145 and the lower ring portion 146 are fixedly connected includes, but is not limited to, ultrasonic welding.

[0049] Referring to FIG. 6, the bottom seat assembly 20 includes a bottom seat 21 fittingly received at the lower end of the sleeve 12, and a first electrode 22, a first insulating member 23, an electrode sleeve 24, a second insulating member 25 and a sealing member 26 which are mounted on the bottom seat 21.

[0050] The bottom seat 21 has a substantially cup-shaped structure, and a connecting tube 211 in communication with the interior of the bottom seat 21 extends downward from the center portion of the bottom surface of the bottom seat 21. The first insulating member 23 and the first electrode 22 are installed in the lower end of the connecting tube 211. The second insulating member 25 and the electrode sleeve 24 are mounted in the upper end of the connecting tube 211. One end of the first electrode 22 is received in the electrode

sleeve 24 and electrically connected to the electrode sleeve 24, and the other end of the first electrode 22 is electrically connected to the power supply device (not shown). The first insulating member 23 is interposed between the connecting tube 211 and the first electrode 22, the second insulating member 25 is interposed between the connecting tube 211 and the electrode sleeve 24 to provide insulation.

[0051] An annular sleeve portion 212 is protruded upwardly from the periphery of the bottom seat 21 along the axial direction of the bottom seat 21, the sealing member 26 is sleeved on the sleeve portion 212, and the bottom of the liquid storage tube 12 abuts against the sealing member 26 to improve the sealing performance and prevent the leakage of the cigarette liquid.

[0052] Referring to FIG. 5, the top cover assembly 30 includes a top cover 31 detachably connected to the connecting seat 13, an adjusting member 32 rotatably sleeved on the upper end of the top cover 31, an air outlet pipe 33 detachably connected to the top cover 31, and a mouthpiece connector 34 detachably connected to the upper end of the air outlet pipe 33.

[0053] Referring further to FIG. 4, the top cover 31 is substantially funnel-shaped. The top cover 31 includes an air inlet cap 311, a connecting ring 312 and an air inlet pipe 313 from top to bottom. The air inlet cap 311, the connecting ring 312 and the air inlet pipe 313 are communicated with each other sequentially.

[0054] The air inlet cap 311 has a substantially cylindrical structure. Two air inlet holes 3111 are oppositely defined in the sidewall of the air inlet cap 311 and communicate with the interior of the air inlet cap 311. A plurality of teeth 3112 corresponding to the grooves 143 extend outward along the radial direction of the air inlet cap 311 from the sidewall of the lower end of the air inlet cap 311. When the operation ring 14 slides upward, the teeth 3112 can pass through the grooves 143. It can be understood that the air inlet hole 3111 may also have only one, or two, or more. It can be understood that the number of the teeth 3112 is equal to the number of the grooves 143.

[0055] The outer wall of the connecting ring 312 is provided with an external thread 3121 which cooperates with the internal thread 131 of the connecting seat 13. The connecting ring 312 is connected to the connecting seat 13 by the engagement of the external thread 3121 and the internal thread 131.

[0056] The adjusting member 32 has a substantially cylindrical structure, and the adjusting member 32 is rotatably sleeved on the air inlet cap 311. The inner sidewall of the adjusting member 32 is provided with two air adjusting grooves 321 corresponding to the air inlet holes 3111. The two air adjusting grooves 321 are oppositely arranged and communicate with the external environment. The upper end of the adjusting member 32 is formed with an abutment portion 322 extending inward along the radial direction of the adjusting member 32. The abutment portion 322 abuts against the upper end surface of the air inlet cap 311 to prevent the adjusting member 32 from coming off.

[0057] In use, the adjusting member 32 is rotated, when the adjusting member 32 is rotated to cause the air adjusting grooves 321 to partially or completely communicate with the air inlet holes 3111, the external air can enter the air inlet holes 3111 via the air adjusting grooves 321; when the adjusting member 32 is rotated to cause the inner sidewall of the adjusting member 32 to seal the air inlet holes 3111, the

external air cannot enter the air inlet holes 3111. It can be understood that by rotating the adjusting member 32, the communication area between the air adjusting grooves 321 and the air inlet holes 3111 can be changed, thereby controlling the amount of intake air.

[0058] The air outlet pipe 33 includes a connecting body 331 and a pipe body 332 detachably connected to the lower end of the connecting body 331. The connecting body 331 has a substantially trumpet-like structure with openings at both ends, and the pipe body 332 has a hollow tubular structure with openings at both ends. In this embodiment, the connecting body 331 and the pipe body 332 are fixedly connected by threads. It can be understood that the connecting body 331 and the pipe body 332 can also be an integral structure, that is, the air outlet pipe 33 is unitary as a whole.

[0059] During installation, the connecting body 331 is fixed to the air inlet cap 311 by screwing, thereby connecting the air outlet pipe 33 to the top cover 31. At this time, the pipe body 332 is received in the air inlet pipe 313. The space between the inner wall of the air inlet pipe 313 and the outer wall of the pipe body 332 forms an air inlet passage 3131 which communicates with the air inlet hole 3111, and the inner space of the pipe body 332 forms an air outlet passage 333.

[0060] The mouthpiece connector 34 is substantially a hollow tubular structure having openings at both ends, and the outer peripheral surface of the lower end of the mouthpiece connector 34 is detachably connected to the inner peripheral surface of the upper end of the connecting body 331 of the air outlet pipe 33 by means of plugging. It can be understood that the mouthpiece connector 34 can also be connected to the air outlet pipe 33 by means of threads, clamps or the like.

[0061] In the embodiment of the present disclosure, the mouthpiece connector 34 can be directly used as a mouthpiece, and the user directly sucks the mouthpiece connector 34 to smoke. It can be understood that a hollow suction member having openings at both ends may also be mounted on the mouthpiece connector 34, and the user sucks the suction member to smoke.

[0062] Referring to FIG. 6, the atomizing assembly 40 includes an atomizing head 41 received in the liquid storage chamber 111, and a second electrode 42 and a third insulating member 43 which are mounted at the lower end of the atomizing head 41.

[0063] The upper end of the atomizing head 41 and the lower end of the air inlet pipe 313 of the top cover 31 are detachably connected by threads, and it can be understood that the connection may be realized by clamps or the like. The inside of the atomizing head 41 is in communication with each of the air inlet passage 3131 and the air outlet passage 333.

[0064] The inside of the atomizing head 41 is provided with a heating member (not shown) and a liquid absorbing member (not shown). The lower end of the second electrode 42 is electrically connected to the electrode sleeve 24, and the upper end of the second electrode 42 is electrically connected to the heating member. The liquid absorbing member is used to absorb the cigarette liquid in the liquid storage chamber 111 through a through hole (not shown) provided on the sidewall of the atomizing head 41 and/or a through hole (not shown) provided on the bottom of the

atomizing head 41, so that the cigarette liquid is heated and atomized by the heating member into smoke for the user to suck.

[0065] Further, the third insulating member 43 is sleeved on the second electrode 42 to provide insulation.

[0066] The use of the atomizer 100 of the present disclosure is described below with reference to the accompanying drawings.

[0067] Referring to FIG. 6 and FIG. 7, the connecting ring 312 is connected to the connecting seat 13 by the engagement of the external thread 3121 and the internal thread 131, whereby the top cover assembly 30 is threadedly connected to the liquid storage assembly 10. When the operation ring 14 is rotated to cause the grooves 143 of the operation ring 14 to align with the teeth 3112 of the top cover 31, the operation ring 14 is pushed toward the top cover assembly 30. After the teeth 3112 pass through the grooves 143, the resisting portions 142 and the teeth 3112 are offset from each other. Thereafter, the operation ring 14 is further rotated to cause the teeth 3112 to partially or completely align with the resisting portions 142 of the operation ring 14. Then, the operation ring 14 is released, and the lower surface of the resisting portions 142 and the upper surface of the teeth 3112 abut against with each other under the restoring action of the elastic member 16. At this time, if the top cover assembly 30 is rotated, the operation ring 14 will rotate together due to the frictional force between the resisting portions 142 and the teeth 3112, thereby preventing the resisting portions 142 from being disengaged from the teeth 3112, and further limiting the upward movement of top cover assembly 30 along the axial direction of the atomizer 100. As a result, the threaded connection between the upper cover assembly 30 and the liquid storage assembly 10 is locked, and the upper cover assembly 30 cannot be easily disassembled from the liquid storage assembly 10.

[0068] When the top cover assembly 30 needs to be disassembled from the liquid storage assembly 10, the operation ring 14 is pushed to slide upward, and the operation ring 14 compresses the elastic member 16 to separate the resisting portions 142 from the teeth 3112. Then, the operation ring 14 is rotated to cause the grooves 143 to align with the teeth 3112, so that the resisting portions 142 and the teeth 3112 are offset from each other. The operation ring 14 slides down and is reset under the elastic force of the elastic member 16. As a result, the locking relationship between the top cover assembly 30 and the liquid storage assembly 10 is removed, thereby enabling the upper cover assembly 30 to be unscrewed and disassembled from the liquid storage assembly 10.

[0069] It can be understood that, in addition to the thread connection between the top cover assembly 30 and the liquid storage assembly 10, other detachable connection manners may also be adopted. For example, a locking groove is provided on the inner peripheral surface of the connecting seat 13, and a clamp is provided on the outer peripheral surface of the connecting ring 312 of the top cover 31, so that the top cover assembly 30 and the liquid storage assembly 10 are detachably connected by clamping; and further for example, the connecting seat 13 and the connecting ring 312 both are made of a magnetic material, the top cover assembly 30 and the liquid storage assembly 10 are detachably connected by magnetic connection.

[0070] It can be understood that the elastic member 16 can be omitted. After the elastic member 16 is omitted, the

restoring of the operation ring 14 needs to be completed by manually sliding the operation ring 14 downward when the grooves 143 are aligned with the teeth 3112. Alternatively, the operation ring 14 may be made of an elastic material, so that after the elastic member 16 is omitted, the operation ring 14 can still be automatically reset by its elastic force.

[0071] It can be understood that the press ring 15 can be omitted. After the press ring 15 is omitted, the operation ring 14 can be movably disposed on the connecting seat 13 by other means. For example, an annular groove is defined in the outer surface of the connecting seat 13 along the circumferential direction of the connecting seat 13, the annular groove has a certain height, and the lower abutting portion 141 is limited between upper and lower groove walls of the annular groove, thereby allowing the operation ring 14 to rotate not only around the central axis of the liquid storage assembly 10, but also to move along the axial direction of the liquid storage assembly 10 within a range defined by the upper and lower groove walls of the annular groove.

[0072] It can be understood that when the operation ring 14 is made of an elastic material, the operation ring 14 is not required to be provided with the grooves 143, and the operation ring 14 is also not required to be rotated. Since the operation ring 14 can be elastically deformed, the upper end of the operation ring 14 with the resisting portions 142 is caused to move until the lower surface of the resisting portions 142 and the upper surface of the teeth 3112 abut against with each other.

[0073] When disassembling, the atomizer 100 provided by the present disclosure needs to firstly slide the operation ring 14 upward and then further rotate the operation ring 14 to separate the resisting portions 142 of the operation ring 14 from the teeth 3112 of the top cover 31. Thereafter, the top cover assembly 30 can be further detached from the liquid storage assembly 10. The disassembly process is relatively complicated, it is difficult for a child to achieve by a single operation, thereby effectively preventing the children from easily opening the atomizer 100 to contact or ingest the cigarette liquid. The present disclosure further provides an electronic cigarette having the above-described atomizer 100. The electronic cigarette has the same technical features as the above-described atomizer 100, and thus has the same technical effects as the above-described atomizer 100.

Second Embodiment

[0074] The atomizer 100 provided in the second embodiment is different from the atomizer 100 in the first embodiment. The main difference of the atomizer 100 in the second embodiment is that, among the lower surface of the resisting portions 142 of the operation ring 14 and the upper surface of the teeth 3112 of the top cover 31, one of the surfaces is provided with protrusions 144, and the other one of the surfaces is provided with recesses 3113 matching with the protrusions 144.

[0075] Referring to FIG. 10 and FIG. 11, in this embodiment, the protrusions 144 are provided on the lower surface of the resisting portions 142, and the recesses 3113 are provided on the upper surface of the teeth 3112. When the resisting portions 142 abut against the teeth 3112, the protrusions 144 are engaged in the recesses 3113, to further prevent the resisting portions 142 from being disengaged from the teeth 3112. Compared with the atomizer 100 of the first embodiment, the connection between the liquid storage assembly 10 and the top cover assembly 30 is more stable.

[0076] It can be understood that the lower surface of the resisting portions 142 and the upper surface of the teeth 3112 can also increase the friction between the two surfaces by providing a knurling or the like, which can also achieve the effect for preventing the resisting portions 142 from being disengaged from the teeth 3112.

[0077] In view of the above-described embodiments of the present disclosure, various changes and modifications can be made by those skilled in the art without departing from the scope of the present disclosure. The technical scope of the present disclosure is not limited to the contents of the specification, and the technical scope thereof should be determined in accordance with the scope of the claims.

1. An atomizer comprising a liquid storage assembly and a top cover assembly, the liquid storage assembly comprising a connecting seat and an operation ring movably disposed on the connecting seat, the operation ring being provided with resisting portions, the top cover assembly comprising a top cover detachably connected to the connecting seat, the top cover being provided with teeth corresponding to the resisting portions, when the operation ring is moved to cause the resisting portions and the teeth to be mutually engaged/disengaged, a detachable connection between the top cover and the connecting seat is locked/unlocked.

2. The atomizer according to claim 1, wherein the operation ring is rotatably sleeved on the connecting seat, and the operation ring is capable of sliding along an axial direction of the connecting seat, the resisting portions is formed by extending radially inward along a radial direction of the operation ring from one end of the operation ring near the top cover, grooves are defined in the resisting portions corresponding to the teeth, the grooves are able to pass through the teeth correspondingly along an axial direction of the operation ring.

3. The atomizer according to claim 2, wherein the atomizer further comprises a press ring disposed at an upper end of the connecting seat, a lower abutting portion is formed by extending radially inward along the radial direction of the operation ring from one end of the operation ring away from the top cover, an upper abutting portion is formed by extending radially outward along a radial direction of the press ring from one end of the press ring near the top cover, an outer peripheral surface of the connecting seat has a flange extending outward along a radial direction of the connecting seat, the lower abutting portion is located between a lower surface of the upper abutting portion and an upper surface of the flange.

4. The atomizer according to claim 2, wherein an outer surface of the connecting seat defines an annular groove along a circumferential direction of the connecting seat, a lower abutting portion is formed by extending radially inward along the radial direction of the operation ring from one end of the operation ring away from the top cover, the lower abutting portion is located between upper and lower groove walls of the annular groove.

5. The atomizer according to claim 3, wherein the operation ring is made of an elastic material, or the atomizer further comprises an elastic member disposed between the operation ring and the press ring, one end of the elastic member elastically abuts against the lower abutting portion, the other end of the elastic member elastically abuts against the upper abutting portion.

6. The atomizer according to claim 1, wherein, for the two mutually engaged surfaces between the resisting portions of the operation ring and the teeth of the top cover, one of the surfaces is provided with protrusions, and the other one of the surfaces is provided with recesses matching with the protrusions.

7. The atomizer according to claim 1, wherein an internal thread is provided on an inner wall of the connecting seat, an external thread matching with the internal thread is provided on an outer wall of the top cover below the teeth, or a locking groove is provided on an inner peripheral surface of the connecting seat, a clamp matching with the locking groove is provided on an outer peripheral surface of the top cover below the teeth, or the connecting seat and the portion of the top cover in contact with the connecting seat are each made of a magnetic material.

8. The atomizer according to claim 7, wherein the top cover assembly further comprises an adjusting member rotatably sleeved on the top cover, at least one air inlet hole is defined in a sidewall of the top cover above the teeth, an air adjusting groove in communication with the external environment is defined in the inner sidewall of the adjusting member corresponds to each air inlet hole, the adjusting member is rotated to cause the air adjusting groove and the corresponding air inlet hole to be communicated with each other or staggered from each other.

9. The atomizer according to claim 8, wherein the top cover assembly further comprises an air outlet pipe received in the top cover and a mouthpiece connector connected to the air outlet pipe, a space between an inner wall of the top cover and an outer wall of the air outlet pipe forms an air inlet passage communicating with the air inlet hole, an inner space of the air outlet pipe forms an air outlet passage communicating with the mouthpiece connector.

10. (canceled)

11. An atomizer comprising a liquid storage assembly and a top cover assembly, the liquid storage assembly comprising a liquid storage tube provided with an opening and an operation ring movably disposed at the opening, the operation ring being provided with resisting portions, the top cover assembly comprising a top cover detachably covering the opening, the top cover being provided with teeth corresponding to the resisting portions, when the operation ring is moved to cause the resisting portions and the teeth to be mutually engaged/disengaged, a detachable connection of the top cover is locked/unlocked.

12. The atomizer according to claim 11, wherein the liquid storage assembly further comprises a connecting seat disposed at the opening, the operation ring is rotatably sleeved on the connecting seat, and the operation ring is capable of sliding along an axial direction of the connecting seat, the resisting portions is formed by extending radially inward along a radial direction of the operation ring from one end of the operation ring near the top cover, grooves are defined in the resisting portions corresponding to the teeth, the grooves are able to pass through the teeth correspondingly along an axial direction of the operation ring.

13. The atomizer according to claim 12, wherein the atomizer further comprises a press ring disposed at an upper end of the connecting seat, a lower abutting portion is formed by extending radially inward along the radial direction of the operation ring from one end of the operation ring away from the top cover, an upper abutting portion is formed by extending radially outward along a radial direction of the

press ring from one end of the press ring near the top cover, an outer peripheral surface of the connecting seat has a flange extending outward along a radial direction of the connecting seat, the lower abutting portion is located between a lower surface of the upper abutting portion and an upper surface of the flange.

14. The atomizer according to claim 12, wherein an outer surface of the connecting seat defines an annular groove along a circumferential direction of the connecting seat, a lower abutting portion is formed by extending radially inward along the radial direction of the operation ring from one end of the operation ring away from the top cover, the lower abutting portion is located between upper and lower groove walls of the annular groove.

15. The atomizer according to claim 11, wherein the operation ring is made of an elastic material.

16. The atomizer according to claim, wherein the atomizer further comprises an elastic member disposed between the operation ring and the press ring, one end of the elastic member elastically abuts against the lower abutting portion, the other end of the elastic member elastically abuts against the upper abutting portion.

17. The atomizer according to claim 11, wherein, for the two mutually engaged surfaces between the resisting portions of the operation ring and the teeth of the top cover, one of the surfaces is provided with protrusions, and the other one of the surfaces is provided with recesses matching with the protrusions.

18. An electronic cigarette comprising an atomizer, the atomizer comprising a liquid storage assembly and a top cover assembly, the liquid storage assembly comprising a liquid storage tube provided with an opening and an operation ring movably disposed at the opening, the operation ring being provided with resisting portions, the top cover assembly comprising a top cover detachably covering the opening, the top cover being provided with teeth corresponding to the resisting portions, when the operation ring is moved to cause

the resisting portions and the teeth to be mutually engaged/disengaged, a detachable connection of the top cover is locked/unlocked.

19. The electronic cigarette according to claim 18, wherein the liquid storage assembly further comprises a connecting seat disposed at the opening, the operation ring is rotatably sleeved on the connecting seat, and the operation ring is capable of sliding along an axial direction of the connecting seat, the resisting portions is formed by extending radially inward along a radial direction of the operation ring from one end of the operation ring near the top cover, grooves are defined in the resisting portions corresponding to the teeth, the grooves are able to pass through the teeth correspondingly along an axial direction of the operation ring.

20. The electronic cigarette according to claim 18, wherein the atomizer further comprises a press ring disposed at an upper end of the connecting seat, a lower abutting portion is formed by extending radially inward along the radial direction of the operation ring from one end of the operation ring away from the top cover, an upper abutting portion is formed by extending radially outward along a radial direction of the press ring from one end of the press ring near the top cover, an outer peripheral surface of the connecting seat has a flange extending outward along a radial direction of the connecting seat, the lower abutting portion is located between a lower surface of the upper abutting portion and an upper surface of the flange.

21. The electronic cigarette according to claim 18, wherein an outer surface of the connecting seat defines an annular groove along a circumferential direction of the connecting seat, a lower abutting portion is formed by extending radially inward along the radial direction of the operation ring from one end of the operation ring away from the top cover, the lower abutting portion is located between upper and lower groove walls of the annular groove.

* * * * *