

May 12, 1964

E. V. CRANE
COMPACTING PRESS

3,132,379

Filed April 12, 1961

5 Sheets-Sheet 1

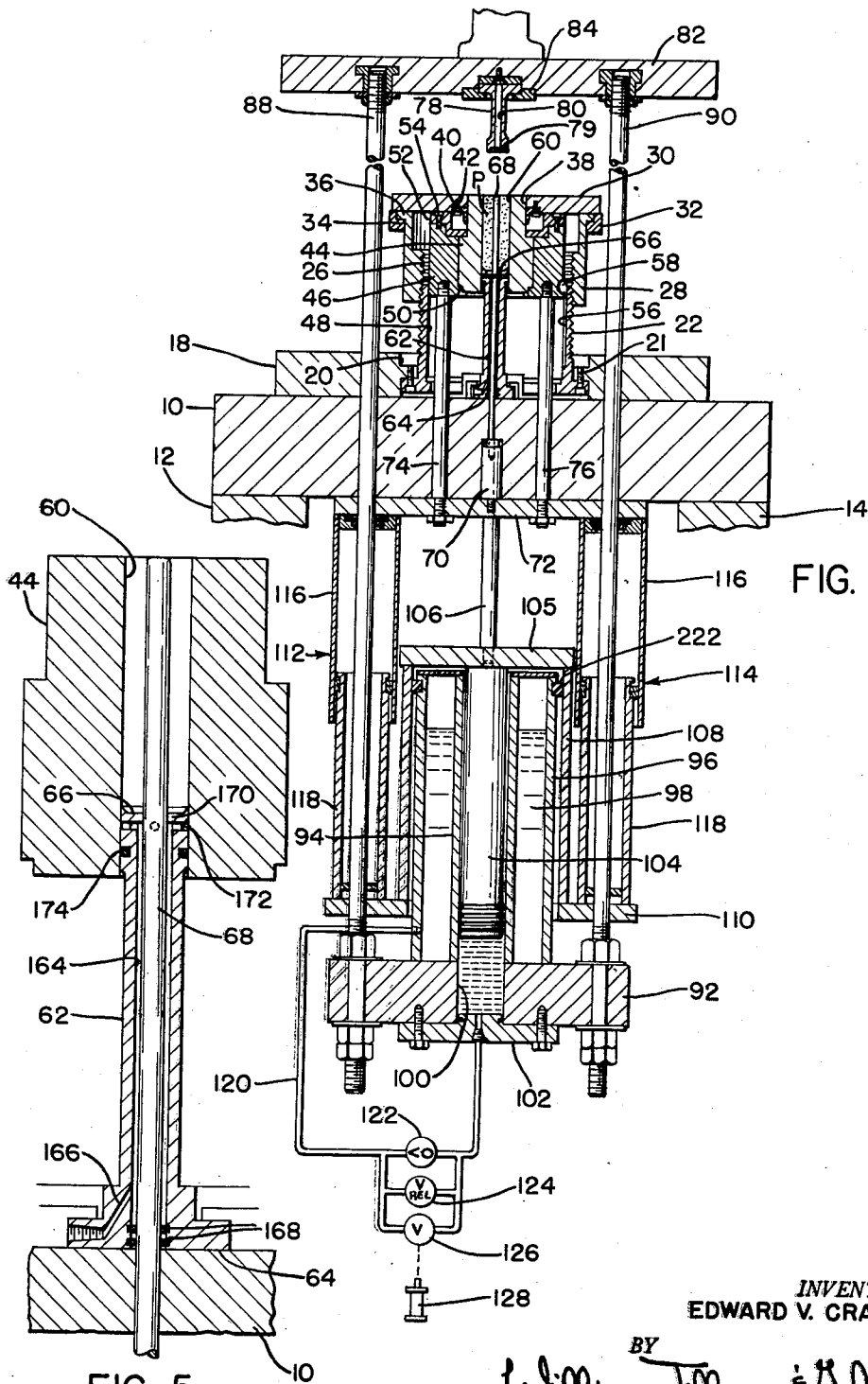

INVENTOR
EDWARD V. CRANE

BY
Williams, Tabor & Schrick
ATTORNEYS

May 12, 1964

E. V. CRANE
COMPACTING PRESS

3,132,379

Filed April 12, 1961

5 Sheets-Sheet 3

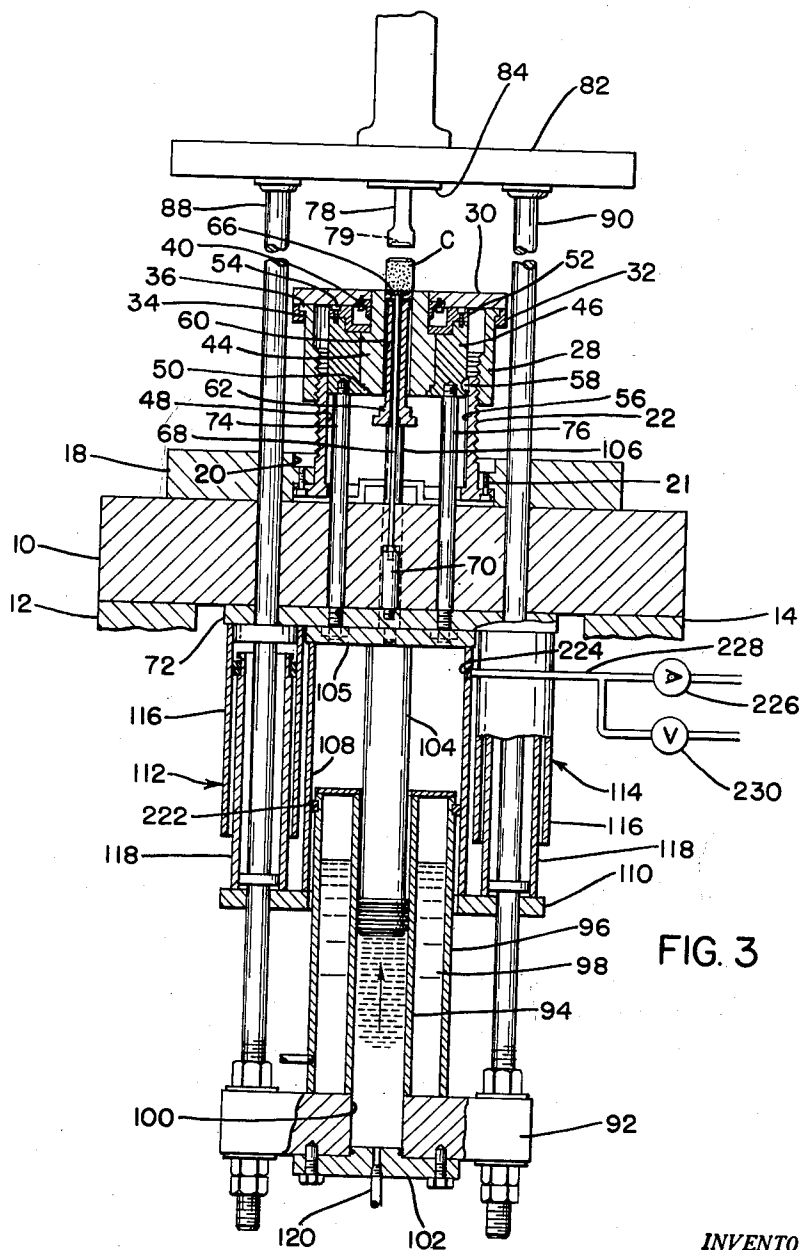

FIG. 3

INVENTOR.
EDWARD V. CRANE

BY
Williams, T. Berry & Schick
ATTORNEYS

May 12, 1964

E. V. CRANE
COMPACTING PRESS

3,132,379

Filed April 12, 1961

5 Sheets-Sheet 4

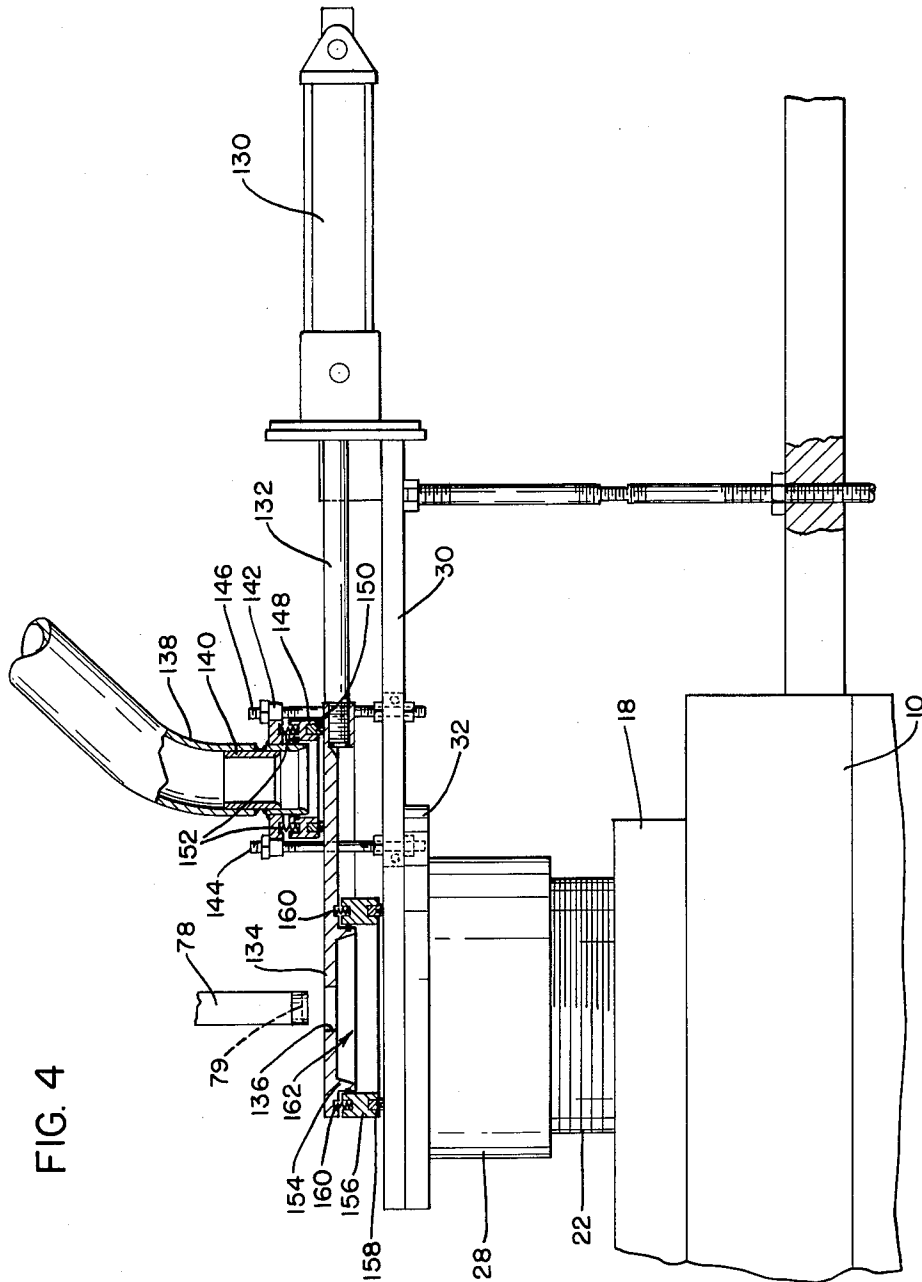

FIG. 4

INVENTOR.
EDWARD V. CRANE

BY
Williams, Tilbury & Sobriets
ATTORNEYS

May 12, 1964

E. V. CRANE
COMPACTING PRESS

3,132,379

Filed April 12, 1961

5 Sheets-Sheet 5

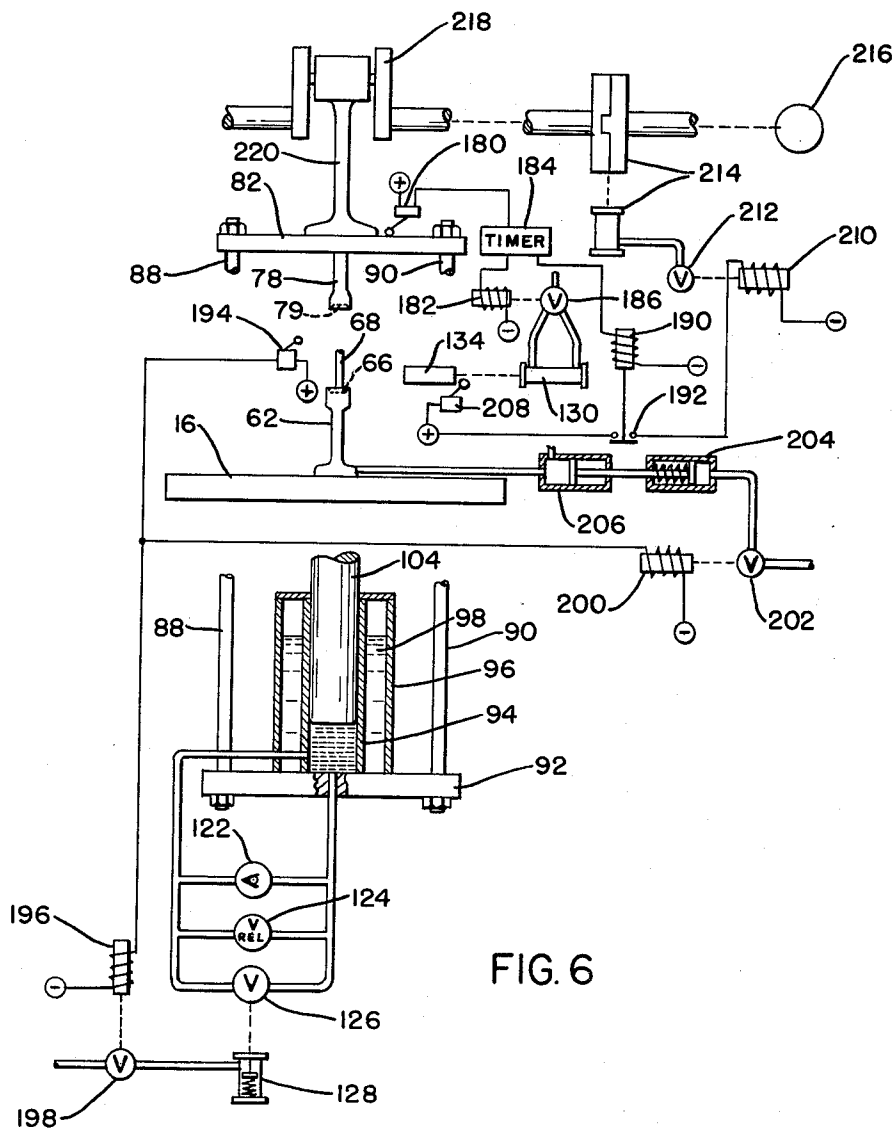

FIG. 6

INVENTOR.
EDWARD V. CRANE

BY
Williams, Tilbury & Lubick
ATTORNEYS

1

3,132,379

COMPACTING PRESS

Edward V. Crane, Canton, Ohio, assignor to
E. W. Bliss Company, Canton, Ohio
Filed Apr. 12, 1961, Ser. No. 102,556
7 Claims. (Cl. 18-16.5)

This invention relates to press apparatus for compacting metal powders and the like, as well as to means for automatically lubricating the compacting punch, die and mandrel for such presses.

As an overall object, the present invention seeks to provide a new and improved compacting press capable of producing an improved product at a higher production rate than previously known presses of this type.

As the name implies, a compacting press of the type described herein is adapted for use in compacting metal powder to produce slugs which are subsequently sintered and employed, for example, as billets in an impact extrusion operation. In order to produce compacts of uniform density as is practical, it is desirable to provide a press having a floating die which moves downwardly at about half the speed of the punch during the compacting operation, the reason being to produce the uniform density desired. In addition, it is necessary to provide means for ejecting the compacted mass out of the die at the completion of the compacting operation. As will be seen, the present invention provides a hydro-pneumatic mechanism for controlling the movements of the die and the ejector mechanism without requiring complicated mechanical movements for accomplishing these functions. At the same time, the hydro-pneumatic mechanism facilitates a higher production rate not easily attainable by the use of a mechanical movement.

Another object of the invention is to provide means for lubricating the die walls and mandrel of a powder compacting press.

In the compacting operation, particularly at high production rates, a large amount of heat is generated which, in the absence of a lubricant, causes the powder to adhere to the die walls and mandrel. In order to successfully compact powder and eject the compacted slug from the die, it has usually been considered necessary to mix the powder with a lubricant to aid in ejection and to produce a more uniform density over the length of the slug. Examples of such lubricants which have been mixed with the powder are zinc stearate, lithium stearate, or stearic acid. The addition of lubricants to the powder, however, presents certain difficulties. Some difficulty is encountered in uniformly mixing the powder with the lubricant while avoiding lumps or local concentrations. In addition, a residue of the lubricant, or its ash inclusions in the final product is a source of local weakness or objectional splitting.

In the present invention, in contrast to previous procedures, the powder to be compacted need not be mixed with a lubricant. Rather, the walls of the die and mandrel are automatically swabbed with a lubricant after each compacting operation, thereby producing the desired lubricating effect while avoiding the undesirable effects produced by mixing a lubricant throughout the powder.

In accordance with one aspect of the invention, a compacting press is provided comprising a vertically reciprocable die which receives powder to be compacted, a punch which is forced into the upper end of the die, and an ejector plunger having its upper end extending into the lower end of the die. During a compacting operation, the lower end of ejector plunger is seated against a supporting member and provides a rigid surface against which powder is compacted. This ejector plunger is connected to a piston which

2

is connected to the punch through connecting rods, the arrangement being such that when the punch moves downwardly, the hydraulic cylinder will move downwardly also; however, the piston and ejector plunger will remain seated against the aforesaid supporting member to provide the necessary surface against which powder is compacted. At the same time, the reciprocable die is connected through telescoping air cylinders to the aforesaid piston whereby the die will float downwardly while compressing air within the telescoping air cylinders. By permitting a fluid to flow through a check valve to the lower end of the aforesaid hydraulic cylinder during the downward stroke of the punch, the fluid will be entrapped within the lower end of the cylinder during the upward stroke to force the piston and ejector plunger upwardly and thereby eject a compacted mass out of the die while the air cylinders return to its original uppermost starting position. The cycle is completed by opening a valve to permit fluid to flow out of the bottom of the hydraulic cylinder while the air cylinders force the aforesaid piston and ejector plunger downwardly while filling the die with a new charge of powder to be compacted.

In accordance with another feature of the invention, the aforesaid ejector plunger is provided with an axially-extending passageway through which a mandrel extends, this mandrel serving to form a core in the compacted slug. By providing radial holes between the passage in the plunger and its outer peripheral surface, and by injecting a lubricant into the passageway in the ejector plunger in timed relationship with the portion of the cycle when the ejector plunger begins its downward stroke to fill the die with a new charge of powder, the lubricant will flow out through the radial holes and be swabbed onto the walls of the die as the plunger moves downwardly. At the same time, the lubricant will be swabbed onto the mandrel, thereby making it unnecessary to mix the powder with a lubricant, a procedure which is undesirable for the reasons pointed out above.

The above and other objects and features of the invention will become apparent from the following detailed description taken in connection with the accompanying drawings which form a part of this specification and, in which:

FIGURE 1 is a cross-sectional view of the compacting tools and hydro-pneumatic means of this invention showing its working parts in the positions they occupy after the die has been filled with powder, but before the punch is brought down into the die to compact the powder therein;

FIGURE 2 is a cross-sectional view similar to that of FIGURE 1, but showing the working parts in the positions they occupy during the compacting stroke of the apparatus;

FIGURE 3 is another cross-sectional view similar to that of FIGURES 1 and 2, but showing the working parts in the positions they occupy when a compacted slug is ejected from the die;

FIGURE 4 is a partially broken-away view of the powder feeding mechanism;

FIGURE 5 is an enlarged view of the ejector plunger, the mandrel and the die of the invention, showing the manner in which a lubricant is swabbed onto the surfaces of the die and mandrel; and,

FIGURE 6 is a schematic illustration of one type of control system which may be used with the compaction apparatus of this invention.

Referring now to FIGURES 1, 2 and 3, and particularly to FIGURE 1, the general organization of the press includes a bolster plate 10 which is supported by bed frame members, not shown, as at 12 and 14. Supported on the bolster plate 10 is the die holder 18. As shown, the die holder 18 is provided with a central aperture 20

which receives an annular or cylindrical member 22 having threads provided on its outer periphery, the member being secured to block 18 by means of bolts 21. Above the cylindrical member 22 is a second cylindrical member or annular nut 28 which supports, on its upper surface, a die table 30. The die table 30 is provided with an annular ring 32 having a flange 34 which is interlocked with a cooperating flange 36 on the upper edge of nut 28, the arrangement being such that the nut 28 may be rotated to raise or lower the die table without rotating the die table itself.

Provided in the die table 30 is a centrally disposed bore 38. Surrounding the lower edge of bore 38 is a bushing 40 which is fastened to the die table 30 as by means of bolts 42. Reciprocally received within the bore 38 and bushing 40 is a die block 44 surrounded by an annular member 46 which is slideable on the inner surface or periphery 48 of the cylindrical member 22. Member 46 is secured to the die block 44 between shoulder 50 and an annular ring 52 which is secured to member 46 by means of bolts 54. Formed on the inner periphery, or wall 48 of the cylindrical member 22, there may be provided a keyway 56 which slidably receives a key 58 located in the annular member 46. The key 58 and the keyway 56 are not, however, required, and may be omitted if desired. With this arrangement, the entire assembly of die block 44, member 46, and the ring 52 may reciprocate within the cylindrical members 22 and 40. As the assembly moves downwardly, for example, the upper reduced diameter portion of the die block 44 will slide on the inner periphery of bore 38 and bushing 40; while the annular member 46 will slide on the inner periphery 48 of cylindrical member 22.

The die block 44 has a centrally disposed bore 60 extending therethrough; and this bore receives, at its lower end, an ejector plunger 62. In its lowermost position, shown in FIGURE 1, the ejector plunger 62 is seated on the bolster plate 10 as at 64 whereby its upper cup shaped end 66 will act as a floor against which powder is compacted. Extending through the ejector plunger 62 is a centrally disposed mandrel 68 which serves to form a core in the compacted slug as will hereinafter be explained. At its lower extremity the mandrel 68 is threaded into a rod 70 which, in turn, is threaded into a horizontally-extending plate or member 72. Secured to the plate 72 are four circumferentially spaced rods, only two of which are shown in FIGURES 1, 2 and 3, and identified by the numerals 74 and 76. These rods contact the lower surface of the annular member 46 of the die assembly whereby the entire die assembly of elements 44, 46 and 52 will reciprocate with the mandrel rod 68 and the plate 72 as a unit.

Disposed above the bore 60 in die block 44 is a punch 78 having an axial bore 80 therein which receives the mandrel rod 68 during a compacting operation. The punch 78 is carried on a punch plate 82 by means of an annular ring 84, substantially as shown. The punch 78 has a cup shaped aperture 79 which is similar to the cup shaped end 66 of the ejector plunger 62. The cup shaped aperture 79 of the punch cooperates with the cup shaped end 66 of the ejector plunger to form a compact or slug C which has beveled upper and lower edges, as shown in FIGURE 3. The beveled edges tend to minimize the effect of, and in some instances may prevent the distortion of the edges of the slug during subsequent handling and treatment of the slug. For example, if the slug were formed with square edges, distortion of the edges during sintering may produce burrs or projections extending from the slug. These edge defects may interfere with the feeding of the slug into an extrusion die.

Threaded into the punch plate 82 and depending downwardly therefrom are a pair of rods 88 and 90 which extend through openings provided in the plate 18, the bolster block 10 and the horizontal plate 72. These rods are connected at their lower extremities to a horizontal

cross member 92 which supports a hydraulic cylinder 94 surrounded by a cylindrical member 96 which forms an annular oil reservoir 98 between the inner periphery of member 96 and the outer periphery of the cylinder 94. Communicating with the cylinder 94 of a bore 100 in cross member 92, the bore being provided at its bottom end with a closure plate 102 which is bolted to the cross member.

Received within the cylinder 94 is a piston member 104 which is connected through a pair of rods 106 to the ejector plunger 62, the arrangement being such that as the piston member 104 moves upwardly, the ejector plunger will be forced upwardly also to eject a compacted mass out of the bore 60. Only one of the rods 106 is shown in FIGURES 1, 2 and 3. One of these rods lies behind the pin 70 while the other rod lies in front of the pin, as will be understood.

Positioned on top of the piston member 104 is a horizontal plate 105. Carried on this plate in depending relationship is a cylindrical skirt 108 which carries, at its lower extremity, an annular ring 110. Between ring 110 and the horizontal plate 72 are a pair of air cylinders 112 and 114, each of which comprises a pair of telescoping parts 116 and 118. The telescoping parts 116 and 118 are sealed such that when member 116 moves downwardly into member 118, for example, the air within the cylinder will be compressed.

A piston ring 222 is located between the inner surface of skirt 108 and the outer periphery of member 96. A port 224 (see FIG. 2) formed in the skirt 108 communicates by means of conduit 228 with a choke 230 and a check valve 226. The check valve 226 is connected to permit the admission of atmospheric air into the space confined between the lower surface of plate 105 and the top of annular cylinder 94 within skirt 108. Piston ring 222 acts as a seal against the passage of air outwardly between the skirt 108 and the outer periphery of member 96, thereby permitting the escape of air from this space to be controlled by the choke 230. In this manner, the dashpot action of the piston ring 222 may be controlled to cushion the downward movement of the ejector.

Connecting the bore 100 and the lower end of cylinder 94 to the bottom of reservoir 98 is a conduit 120 having a check valve 122 therein which permits liquid to flow from the reservoir into the bottom of cylinder 94 while preventing the return of liquid into the reservoir from the cylinder. In shunt with check valve 122 is a pressure relief valve 124 and a controlled valve 126 which is operated by means of an air cylinder 128. When the punch 78, punch plate 80, cross member 92, and cylinder 94 move downwardly to expand the chamber below piston member 104, the check valve 122 will open to permit liquid to flow from reservoir 98 to the bottom of the cylinder. However, on the upward stroke of the punch, the check valve 122 will prevent the return of liquid into the reservoir, meaning that the piston member 104, rods 106, and the ejector plunger 62 will be forced upwardly. Pressure relief valve 124 serves to limit the upward pressure to provide protection in case of a binding action or the like on ejector 62. In order, then, to return the piston member 104 to its position shown in FIGURE 1, the valve 126 must be opened by air cylinder 128 to permit the liquid at the lower end of cylinder 94 to flow back into the reservoir 98.

Referring now to FIGURE 4, the powder feed mechanism of the press is shown, it being understood that this mechanism extends transversely with respect to the press structure as shown in FIGURES 1, 2 and 3. It comprises a pneumatic cylinder 130 which is connected through a piston rod 132 to a feed carriage 134. Formed in the left-hand portion of the feed carriage 134, as shown in FIGURE 4, is a bore 136 adapted to register with a delivery tube 138 which leads to a metal powder storage bin, not shown. The lower end of the feed tube 138 fits over a

5

cylindrical member 140 which is welded or otherwise securely fastened to a bracket 142. The bracket 142, in turn, is supported by means of threaded connector studs 144 and 146 to the die table 30. Below the bracket 142 is an annular member 143 having a seal 150 provided in its lower edge which engages the surface of the feed carriage 134. This member 143 is forced downwardly against the upper surface of the feed carriage by means of springs 152 interposed between the bracket 142 and the member 143, the arrangement being such that sufficient pressure will be exerted on the seal 150 to restrain powder from being spread over the upper surface of the feed carriage 134.

Depending downwardly from the left-hand end of the feed carriage 134, and concentric with the bore 136, is an annular flange 154. Surrounding this flange is a ring member 156 which, like member 143, has in its bottom surface a seal 158 which rides on the upper surface of the die table 30. Interposed between ring member 156 and the feed carriage 134 are coil springs 160 which serve to force the member 156 and the seal 158 into engagement with the die table 30 and restrain powder from being spread over the table.

With the arrangement shown, the cylinder 130 may be actuated to move the feed carriage 134 to the right as shown in FIGURE 4, until bore 136 registers with the bottom of feed tube 138. At this point, the powder in the feed tube 138 will flow into the central cavity 162 formed by flange 154 and ring member 156. Thereafter, the cylinder 130 will be actuated to move the feed table 134 to the left as shown in FIGURE 4 whereby the cavity 162 will be positioned over the bore 60 in die block 44 such that the powder may be drawn into the bore by downward movement of ejector plunger 62 preparatory to a compacting operation.

Referring now to FIGURE 5, the ejector plunger 62 is provided with an axially-extending inner bore 164 through which the mandrel rod 68 extends. As shown, the main portion of the bore 164 has a diameter substantially larger than that of the mandrel rod 68 to provide an annular passageway around the mandrel. This passageway is connected through hole 166 to a flexible hose, not shown, which is adapted to deliver a lubricant to the bore 164. O-rings 168 seal the lower end of the annular passageway to prevent leakage from the bottom of the bore. Clearance between the ejector and the mandrel rod 68 at 170 permits lubricant to be forced up into that area and out through radial holes 172 onto the surface of bore 60 between the ejector plunger and the die. An O-ring 174 prevents the escape of this lubricant to the bottom.

When the ejector plunger 62 is at top stroke, a shot of lubricant is injected through hole 166 into the passageway formed between the wall of bore 164 and mandrel rod 68, thereby forcing the lubricant out through radial holes 172 and onto the peripheral surface of bore 60. At that time, the ejector plunger 62 is forced downwardly by the air cylinders 112 and 114. This downward movement of the plunger wipes lubricant on the walls of both the mandrel rod 68 and the bore 60, and at the same time draws the next charge of powder into the die for compacting. Thus, with this method, it becomes unnecessary to mix a lubricant with the powder before compacting since the lubricant is automatically supplied to the die and mandrel during each compacting cycle.

Referring again to FIGURE 1, the positions of the parts of the press shown are those which they will occupy just before the punch 78 is forced down into the bore 60 to effect a compacting operation. At this point, powder P will have been charged into the bore by the powder feed mechanism shown in FIGURE 4. The punch plate 82 and punch 78 are forced downwardly into bore 60 by means of a conventional crankshaft-type press, not shown. In this process, the rods 88 and 90 as well as the cross member 92 will be forced downwardly also, thereby pulling the cylinder 94 and reservoir 98 along with it. The

6

plate 105, rods 106 and ring 110, however, cannot move downwardly since such downward movement is prevented by the ejector plunger 62 which is seated on bolster plate 10 at 64. As cross member 92 moves downwardly with the cylinder 94, the check valve 122 will open to permit liquid to flow from reservoir 98 into the bottom of the cylinder 94. At the same time, due to the friction between the powdered metal which is being compacted by the punch 78, and the die block 44, as well as mandrel 68, the entire assembly of the die block, the members 46 and 52, and the mandrel 68 will float downwardly with horizontal plate 72 while compressing the air within cylinders 112 and 114. This is shown in FIGURE 2 where it can be seen that the plate 72 as well as the die assembly has moved downwardly. Plate 72 moves downwardly on rods 88 and 90, while the die assembly moves downwardly on the surfaces of bore 38 and flange 40 as well as the inner peripheral surface 48 of cylindrical member 22. At the same time, the members 116 and 118 of each air cylinder 112 and 114 have telescoped to thereby compress the air within the cylinders. Also, the space between the lower end of piston 104 and the plate 102 has increased, and this space is filled with oil flowing through the check valve from reservoir 98.

When punch 78 reaches its lowermost position and begins its upward stroke, the compacting operation will have been completed with the powder being compacted against the upper surface 66 of ejector plunger 62 which did not move downwardly. As the punch 78 and rods 88 and 90 move upwardly, they will carry with them the cross members 92 and the cylinder 94. Since, however, the oil at the bottom of cylinder 94 is now trapped by the check valve 122, the piston 104 must move upwardly also, and this upward movement of the piston carries with it the plate 105, the ring 110 and the rods 106 which are connected to the ejector plunger 62. As the ejector plunger moves upwardly, it will force the compacted mass out of bore 60; and, simultaneously, the upward movement of ring 110 will force the air cylinders 112 and 114 upwardly. In this process, the plate 72 as well as the entire die assembly are also forced upwardly into their original positions which they assumed at the start of the cycle. The pressure relief valve 124 will prevent an excessive buildup of pressure beneath the piston 104 due to any binding or to reaching the stop position of the ejector plunger 62.

The positions of the parts of the press when the ejector plunger reaches its uppermost position are shown in FIGURE 3. At this point, the air cylinders 112 and 114 will be fully telescoped and the air within these cylinders will be at maximum pressure since the piston 104 has been forced upwardly by the column of oil in cylinder 94 beneath the piston. At this point, the compacted slug C will have been ejected out of bore 60. Thereafter, the cylinder 130 shown in FIGURE 4 is pressurized to move the feed carriage 134 over the bore 60, thereby pushing the previously compacted slug C off of the die table 30 and positioning the cavity 162 over the bore 60. After the cavity 162 is positioned over the bore, the valve 126 is opened by air cylinder 128 to permit oil to flow from the bottom of cylinder 94 back into reservoir 98, thereby permitting the air cylinders 112 and 114 to force the piston 104 and the ejector plunger 62 downwardly until its lower surface seats against the bolster plate 10 at 64. Just before the ejector plunger 62 moves downwardly, a lubricant is injected into bore 164 and is forced through radial passages 172 onto the peripheral surface of bore 60 as well as onto the surface of mandrel rod 68. Thus, as the ejector plunger 62 moves downwardly, a lubricant such as a solution of zinc stearate in benzene, is swabbed onto the surfaces of these two members. Simultaneously, a new charge of powder is drawn into the bore 60 preparatory to the succeeding compacting operation.

When the ejector plunger 62 reaches its lowermost position, the cylinder 130 will be pressurized to move the

feed carriage 134 out of registry with the bore 60 whereby the punch 78 may be forced downwardly into the bore to start a new cycle of operation. The height of the column of powder charged into bore 60 may be adjusted by turning the large annular nut 28 to raise or lower the die table 30.

Control apparatus for effecting the foregoing functions is shown in FIGURE 6, it being understood that the particular control apparatus disclosed herein is for purposes of illustration only, and that other types of control systems may be employed to effect the same results.

Referring to FIGURE 6, when the punch plate 82 reaches its uppermost position, it will close a limit switch 180 which will energize a solenoid 182 through timer circuitry 184 to open valve 186, thereby pressurizing cylinder 130 to force the feed carriage 134 to the left whereby it will be positioned over the die. At the same time, the timer 184 will energize the solenoid 190 to close contacts 192; however, these contacts will not be closed until after the feed carriage 134 has moved to the left.

When the feed carriage 134 is positioned over the die, it will trip a limit switch 194 which will energize solenoid 196 to open valve 198 whereby air pressure will be admitted to cylinder 128 to open valve 126, thereby permitting oil to flow from the bottom of cylinder 94 to reservoir 98, whereupon the piston 104 and ejector plunger 62 move downwardly to draw a new charge of powder into the die. When the limit switch 194 closes, it also energizes solenoid 200 to open valve 202 whereby air cylinder 204 is pressurized to inject a lubricant into the ejector plunger 62 by means of piston pump 206, this pump being connected to a source of a lubricant, not shown. Thus, as the ejector plunger 62 moves downwardly, a lubricant will be swabbed onto the walls of the die as well as the mandrel 68.

After the die has been filled with a new charge of powder and the die walls and mandrel swabbed with lubricant, the timer 184 will deenergize the solenoid 182 whereby the valve 186 will pressurize the cylinder 130 to move the feed carriage 134 to the right. As carriage 134 moves to the right, limit switch 194 is opened to close valves 198 and 202 whereby the springs provided in cylinders 128 and 204 will force their associated pistons to their original positions. When feed carriage 134 reaches its extreme right position, it will close limit switch 208, and since solenoid 190 is energized and contacts 192 are closed at this time by the timer 184, the solenoid 210 will be energized to open valve 212 and engage a pneumatic clutch 214. The clutch 214, in turn, serves to connect a motor 216 to a crankshaft 218 which is connected to the punch plate 82 through connecting rod 220. The clutch 214 is such that when it engages it will rotate the crankshaft 218 through one complete revolution and stop. In this process, the powder within the die is compacted and at the completion of 360° of revolution of the crankshaft 218, the limit switch 180 is again closed to repeat the cycle.

The present invention thus provides a compacting press in which no complex mechanical movement is required to actuate the die and other moving parts of the device, which has a very high production rate, and which automatically provides for lubrication of the die and mandrel without requiring mixing of a lubricant with the powder and its attendant difficulties.

Although the invention has been shown in connection with a certain specific embodiment, it will be readily apparent to those skilled in the art that various changes in form and arrangement of parts may be made to suit requirements without departing from the spirit and scope of the invention.

I claim:

1. A compacting press for metal powders and the like comprising a vertically reciprocable die having a vertical bore extending therethrough for the reception of a powder

to be compacted, a vertically reciprocable punch adapted to be forced into the upper end of said bore, an ejector plunger having its upper end extending into the lower end of said bore to provide a bottom surface against which powder is compacted, means for limiting downward movement of the ejector plunger beyond a point where its upper end extends into the bore, hydraulic cylinder means for moving said ejector plunger upwardly from said point into the bore at the completion of a compacting operation to force a compacted mass out of the top of the bore, said hydraulic cylinder means having an outer cylinder closed at its bottom and open at its top, means connecting said outer cylinder to said punch whereby it will reciprocate with the punch, a piston member received within the open top end of said outer cylinder and reciprocable therein above a column of substantially non-compressible fluid, means connecting said piston member to the ejector plunger, means for increasing the volume of said column of non-compressible fluid when the punch and outer cylinder move downwardly, means for preventing the volume of said column of non-compressible fluid from decreasing when said punch and outer cylinder move upwardly, and means including telescoping cylinders containing a compressible fluid connecting said piston member to the die.

2. A compacting press for metal powders and the like comprising a vertically reciprocable die having a vertical bore extending therethrough for the reception of a powder to be compacted, a vertically reciprocable crank-driven punch adapted to be forced into the upper end of said bore, an ejector plunger having its upper end extending into the lower end of said bore to provide a bottom surface against which powder is compacted, means for limiting downward movement of the ejector plunger beyond a point where its upper end extends into the bore, hydraulic cylinder means for moving said ejector plunger upwardly from said point into the bore at the completion of a compacting operation to force a compacted mass out of the top of the bore, said hydraulic cylinder means comprising an outer cylinder connected to said punch and reciprocable therewith, a piston member reciprocable within said outer cylinder and connected to said ejector plunger, a liquid reservoir, check valve means connecting the liquid reservoir to the bottom of said outer cylinder whereby liquid will flow from the reservoir to the bottom of the cylinder as the cylinder and punch move downwardly, and pre-pressurized, two-piece, telescoping air cylinder interposed between said piston member and said vertically reciprocable die, whereby said cylinder is compressed during the compacting action of said punch to permit said die to shift downwardly, and said cylinder is expanded to shift said die upwardly when said punch withdraws from said die.

3. A compacting press for metal powders and the like comprising a die having a vertical bore extending therethrough for the reception of a powder to be compacted, a vertically reciprocable punch adapted to be forced into the upper end of said bore, an ejector plunger having its upper end extending into the lower end of said bore to provide a bottom surface against which powder is compacted, means for limiting downward movement of the ejector plunger beyond a point where its upper end extends into the bore, means for cushioning the downward movement of said ejector, hydraulic cylinder means for moving said ejector plunger upwardly from said point into the bore at the completion of a compacting operation to force a compacted mass out of the top of the bore, said hydraulic cylinder means comprising an outer cylinder connected to said punch and reciprocable therewith, a piston member reciprocable within said outer cylinder and connected to said ejector plunger, a liquid reservoir, check valve means connecting said liquid reservoir to the bottom of said outer cylinder whereby liquid will flow from the reservoir into the bottom of the outer cylinder on the downward stroke of said punch and said outer cylinder,

said check valve means serving to prevent liquid from flowing from the lower end of the outer cylinder to said reservoir on the upward stroke of said punch whereby the piston member and ejector plunger will be forced upwardly to eject a compacted mass out of said bore, powder loading means including powder delivery tube means; powder receiving means adapted to be shiftably positioned beneath said powder delivery tube means to receive a charge of powder therefrom; and crank synchronized means to shift said powder receiving means from beneath said powder delivery tube means to pass over and center on said die bore after a compacted mass has been ejected therefrom, and a valve device operable when said powder loading means is over the top of said bore for permitting liquid to flow from the lower end of said outer cylinder to said reservoir, the arrangement being such that when said valve device opens the piston member and ejector plunger will move downwardly to charge said bore with a new supply of powder to be compacted.

4. A compacting press for metal powders and the like comprising a vertically reciprocable die having a vertical bore extending therethrough for the reception of a powder to be compacted, a vertically reciprocable punch adapted to be forced into the upper end of said bore, ejector plunger having its upper end extending into the lower end of said bore to provide a bottom surface against which powder is compacted, means for limiting downward movement of the ejector plunger beyond a point where its upper end extends into the bore, hydraulic cylinder means for moving said ejector plunger upwardly into the bore at the completion of a compacting operation to force a compacted mass out of the top of the bore, said hydraulic cylinder means comprising an outer cylinder connected to said punch and reciprocable therewith, a piston member reciprocable within said outer cylinder and connected to said ejecting plunger, a liquid reservoir, check valve means connecting said liquid reservoir to the bottom of said outer cylinder whereby liquid will flow from the reservoir to the bottom of the cylinder during the downward stroke of said punch and said outer cylinder, said check valve means serving to trap liquid within the lower end of said outer cylinder during the upward stroke of said punch whereby said piston member and the ejector plunger connected thereto will be forced upwardly to eject a compacted mass out of said bore, powder loading means including powder delivery tube means; powder receiving means adapted to be shiftably positioned beneath said powder delivery tube means to receive a charge of powder therefrom; and crank synchronized means to shift said powder receiving means from beneath said powder delivery tube means to pass over and center on said die bore after a compacted mass has been ejected therefrom, a valve device actuatable when said powder loading device has been moved over the top of said bore for

permitting liquid to flow from the bottom of said outer cylinder to said reservoir whereby the piston member and ejector plunger will move downwardly to fill said bore with a new charge of powder to be compacted, and air cylinder means interposed between said piston member and said reciprocable die whereby the die may move downwardly upon the downward stroke of the punch while compressing the air within said air cylinders, said air cylinders serving to return the die to its uppermost position upon the upward stroke of said punch.

5. A compacting press as claimed in claim 1 including means for lubricating the walls of said bore after each compacting cycle comprising an axially-extending passageway in said ejector plunger, radial holes extending between said passageway and the outer peripheral surface of the plunger, and means for forcing a lubricant into said passageway and out through said holes after the plunger has ejected a compacted mass from the bore, the arrangement being such that when the plunger retracts from said one end of the bore preparatory to a succeeding compacting operation it will wipe the lubricant onto the wall of the die bore.

6. A compacting press as claimed in claim 5 wherein said radial holes are provided at the end of the plunger which extends into said other end of the bore.

7. A compacting press as claimed in claim 1 including a mandrel axially slideable within said plunger and extending into said bore, means for lubricating the walls of said bore and said mandrel after each compacting cycle comprising an annular chamber formed in said plunger and surrounding said mandrel, radial holes extending between said annular passageway and the outer peripheral surface of the plunger, and means for forcing a lubricant into said passageway and out through said holes after the plunger has ejected a compacted mass from the bore, the arrangement being such that when the plunger retracts from said one end of the bore preparatory to a succeeding compacting cycle it will wipe the lubricant onto the surfaces of said bore and said mandrel.

References Cited in the file of this patent

UNITED STATES PATENTS

384,872	Simpson	June 19, 1888
523,797	Leonhardt	July 31, 1894
994,349	Updegraff	June 6, 1911
1,339,712	Pauley	May 11, 1920
2,398,227	Hubbert	Apr. 9, 1946
2,449,257	Tucker	Sept. 14, 1948
2,509,783	Richardson	May 30, 1950
2,556,951	Weidner	June 12, 1951
2,651,180	Haller	Sept. 8, 1953
2,810,929	Willi	Oct. 29, 1957
2,825,092	Hatch et al.	Mar. 4, 1958