

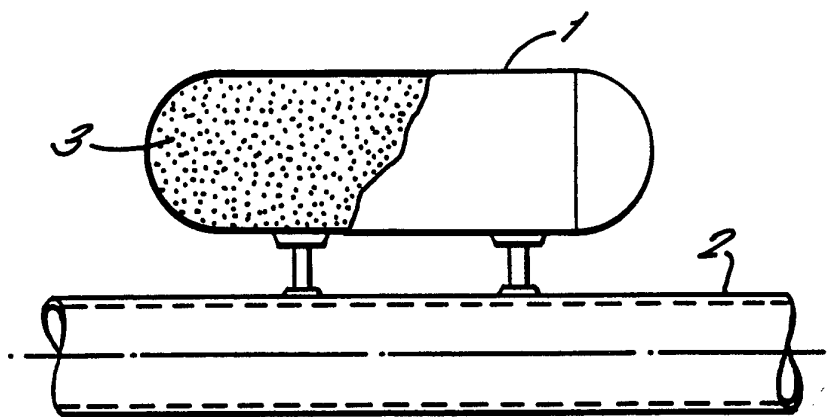

INTERNATIONAL APPLICATION PUBLISHED UNDER THE PATENT COOPERATION TREATY (PCT)

| | | |
|---|-----------|--|
| (51) International Patent Classification ⁵ : F16L 59/14, 11/133, 11/12 | A1 | (11) International Publication Number: WO 94/04865 (43) International Publication Date: 3 March 1994 (03.03.94) |
| (21) International Application Number: PCT/GB93/01693 (22) International Filing Date: 10 August 1993 (10.08.93) (30) Priority data: 9217061.2 12 August 1992 (12.08.92) GB 9217060.4 12 August 1992 (12.08.92) GB 9221020.2 6 October 1992 (06.10.92) GB (71)(72) Applicant and Inventor: CORBISHLEY, Terrence, Jeffrey [GB/GB]; The Downs, 108 Heath Road, Petersfield, Hampshire GU31 4EL (GB). (74) Agent: BOULT WADE TENNANT; 27 Furnival Street, London EC4A 1PQ (GB). | | (81) Designated States: AT, AU, BB, BG, BR, BY, CA, CH, CZ, DE, DK, ES, FI, GB, HU, JP, KP, KR, KZ, LK, LU, MG, MN, MW, NL, NO, NZ, PL, PT, RO, RU, SD, SE, SK, UA, US, VN, European patent (AT, BE, CH, DE, DK, ES, FR, GB, GR, IE, IT, LU, MC, NL, PT, SE), OAPI patent (BF, BJ, CF, CG, CI, CM, GA, GN, ML, MR, NE, SN, TD, TG). Published <i>With international search report.</i> |

(54) Title: IMPROVEMENTS IN MARINE AND SUBMARINE APPARATUS



(57) Abstract

The invention relates to improvements in an apparatus, such as pipelines (2) and associated equipment and to a method of making, insulating, providing buoyancy to, recovering and installing submarine apparatus. The marine or submarine apparatus comprises an impermeable enclosure (1) associated with the apparatus (2), which enclosure is tightly packed with hollow microspheres (3) to a density where, when submerged in use, the internal pressure of the microspheres is greater than or substantially equal to the water pressure on the apparatus.

FOR THE PURPOSES OF INFORMATION ONLY

Codes used to identify States party to the PCT on the front pages of pamphlets publishing international applications under the PCT.

| | | | | | |
|----|--------------------------|----|--|----|--------------------------|
| AT | Austria | FR | France | MR | Mauritania |
| AU | Australia | GA | Gabon | MW | Malawi |
| BB | Barbados | GB | United Kingdom | NE | Niger |
| BE | Belgium | GN | Guinea | NL | Netherlands |
| BF | Burkina Faso | GR | Greece | NO | Norway |
| BG | Bulgaria | HU | Hungary | NZ | New Zealand |
| BJ | Benin | IE | Ireland | PL | Poland |
| BR | Brazil | IT | Italy | PT | Portugal |
| BY | Belarus | JP | Japan | RO | Romania |
| CA | Canada | KP | Democratic People's Republic of Korea | RU | Russian Federation |
| CF | Central African Republic | KR | Republic of Korea | SD | Sudan |
| CG | Congo | KZ | Kazakhstan | SE | Sweden |
| CH | Switzerland | LI | Liechtenstein | SI | Slovenia |
| CI | Côte d'Ivoire | LK | Sri Lanka | SK | Slovak Republic |
| CM | Cameroon | LU | Luxembourg | SN | Senegal |
| CN | China | LV | Latvia | TD | Chad |
| CS | Czechoslovakia | MC | Monaco | TG | Togo |
| CZ | Czech Republic | MG | Madagascar | UA | Ukraine |
| DE | Germany | ML | Mali | US | United States of America |
| DK | Denmark | MN | Mongolia | UZ | Uzbekistan |
| ES | Spain | | | VN | Viet Nam |
| FI | Finland | | | | |

IMPROVEMENTS IN MARINE AND SUBMARINE APPARATUS

The invention relates to improvements in marine and submarine apparatus, such as pipelines and associated equipment, and to a method of making, insulating, providing buoyancy to, recovering and installing submarine apparatus.

With the growth of the offshore oil and gas industry, it has been necessary to install prefabricated pipelines between offshore oil and gas fields and onshore processing facilities and between different offshore locations. These may be for processing purposes or for loading the oil or gas into shuttle tankers from offshore loading buoys.

To meet the need to install pipelines with a high degree of reliability, it is possible to use barges and vessels with several aligned welding, inspection and coating stations that can fabricate a pipeline from a large number of short lengths of coated pipe, typically 10 metres long. The welded joints of the pipeline have then to be inspected and coated before the pipeline is lowered to the sea bed down a long curved stinger or ramp. As an alternative, suitable for pipelines of a smaller diameter, the pipeline will be supplied in long lengths which are found on a large reel housed on a vessel. The pipeline is unreel from the vessel, straightened to remove the curvature created by the reeling process, and then lowered directly into the sea and down to the sea bed.

A further alternative is to fabricate, at a suitable shore site, a bundled assembly formed of a pipeline or group of pipelines housed within a large diameter outer steel pipeline, known as a carrier pipe. The void space within the carrier pipe and around the pipelines housed

within it is sealed to prevent the ingress of water when towed. For towing from its shore site to its installation site, the fabricated bundle assembly is needed to be provided with buoyancy and preferably having just sufficient submerged unit weight (i.e. it should be negatively buoyant) for the purposes of towing. Towing can be either on-bottom, off-bottom or controlled depth towing.

It is also often necessary to tow and install other equipment, apart from pipelines, such as platforms, manifolds, templates, storage units, valves, well christmas trees and other structures, which also need to be provided with buoyancy to aid their installation. Where apparatus which is only partially submerged is to be installed, positive buoyancy must be provided.

Pipelines and underwater equipment are often needed to be recovered, for example for repair, and positive buoyancy is required to aid recovery.

The buoyancy of a structure is presently achieved by the introduction of a medium, having a specific gravity less than water, typically air or other gas. Other suitable mediums include open or closed cell foams. The gas and foams compress with increasing applied pressure at deeper and deeper depths of water and will correspondingly expand with decreasing applied pressure. Buoyancy may also be provided by more consolidated materials, again with a specific gravity less than water, such as polyurethane which has been blown or foamed with a gas to form a closed cell structure. Polyurethane foams and the like are usually encapsulated in a thin skin of more dense material following application of the buoyant material.

During installation, operation or recovery submarine pipelines and equipment are liable to mechanical damage when they suffer impact, for example from fishing gear such

as trawl boards, beams, anchors or heavy objects dropped overboard from vessels. The protection of pipelines lying on the sea bed is currently achieved by applying a substantial layer of concrete or elastomeric material. For towed bundles of pipes, the carrier pipe presently also provides protection to the individual pipelines housed within it.

In use, pipelines and underwater equipment are often required to maintain certain fluid temperatures, preventing adverse affects such as "hydrate" formation or wax deposition. Thermal insulation of the equipment helps to avoid this and is currently achieved by the application to the external surface of the equipment suitable insulation material. The materials are presently applied by various processes including extrusion, impingement, wrapping and casting.

It is an object of the present invention to provide marine and submarine apparatus, including pipelines and associated equipment, which can be provided with temporary or permanent buoyancy, or the submerged unit weight thereof can be reduced, to aid its installation or recovery, which apparatus may additionally be thermally insulated and protected from mechanical impact damage using the buoyancy providing means.

It is a further object of the present invention to provide a method of installing and recovering marine and submarine apparatus.

According to the invention there is provided marine or submarine apparatus comprising an impermeable enclosure associated with said apparatus, which enclosure is tightly packed with hollow microspheres to a density where, when submerged or partially submerged in use, the internal pressure on the microspheres is greater than or substantially equal to the water pressure on the apparatus.

According to the invention there is also provided a submarine flowline comprising a pipeline, a group of pipelines, or combination of pipeline(s) and associated equipment located within an impermeable enclosure with a space between said enclosure and flowline, which space is filled with tightly packed microspheres to a density where, when submerged in use, the internal pressure on the microspheres is greater than or substantially equal to the external water pressure on the flowline.

The invention also provides a method of installing or recovering marine or submarine apparatus comprising the steps of filling an enclosure associated with said apparatus with tightly packed microspheres to a density where, when submerged in use, the internal pressure on the microspheres is greater than or substantially equal to the water pressure on the apparatus.

It is to be understood that the term "apparatus" refers to individual pieces of equipment, structures or combinations of the aforesaid and the like.

Preferred embodiments of the invention will now be described, by way of example only, with reference to the accompanying drawings, in which:-

Figure 1 is a side elevation of a piece of underwater equipment according to the invention to which is attached a buoyancy enclosure, a part of which has been cut away for ease of reference;

Figure 2 is a side elevation of a cross-section of a piece of underwater equipment according to the invention in which a buoyancy enclosure is provided by a compartment of the equipment;

Figure 3 is a side elevation of a cross-section of of a piece of underwater equipment according to the invention showing a buoyancy enclosure enclosed in a compartment of the equipment.

Figure 4 is a side elevation of a cross-section of a piece of underwater equipment according to the invention surrounded by a buoyancy enclosure;

Figure 4a is an end elevation of a cross-section of Figure 4 taken on the line IV-IV;

Figure 5 is a side elevation of a cross-section of a piece of underwater equipment according to the invention surrounded by a buoyancy enclosure;

Figure 5a is an end elevation of a cross-section of Figure 5 taken on the line V-V;

Figure 6 is a side elevation of a cross-section of a pipeline according to the invention surrounded by a buoyancy enclosure;

Figure 7 is a side elevation of a cross-section of a valve assembly according to the invention surrounded by a buoyancy enclosure;

Figure 8 shows a side elevation of a partial cross-section of a pipeline according to the invention surrounded by a buoyancy enclosure;

Figure 9 is an end elevation of a cross-section of Figure 8 taken on the line IX-IX;

Figure 10 shows a side elevation of a partial cross-section of a pipeline according to the invention surrounded by a buoyancy enclosure;

Figure 11 is an end elevation of a cross-section of Figure 8 taken on the line XI-XI;

Figure 12 is a side elevation of a cross-section of a pipeline according to the invention showing a thermal strain resisting bulkhead;

Figure 13 is a side elevation of a cross-section of a pipeline according to the invention showing a field joint; and

Figure 14 is a side elevation of a cross-section of a buoyancy enclosure being filled with microspheres.

Referring to Figure 1, there is shown an item of underwater equipment (2), such as a piece of pipeline, to which is attached an impermeable enclosure (1) containing tightly packed hollow ceramic microspheres (3) and sealed to prevent the ingress of water. The enclosure may be made of an elastomeric material, such as rubber or a rubber fabric composition, or a more rigid material such as steel. A wide range of materials are suitable for the construction of the enclosure (1). Suitable elastomeric materials such as polyethylene, polyurethane, polyvinylchloride, polyolefines, glass reinforced resins, SBR or EPDM. The construction and thickness of the enclosure (1) should be such as to avoid tearing and may incorporate one or more layers of reinforcing material or a wound wire or textile chord. Reinforcing ribs or slats may be incorporated to stiffen the enclosure (1). The void space within the enclosure (1) surrounding the microspheres (3) may be filled with a vacuum or a gas or liquid such as air or water. The enclosure (1) can be attached to the structure (2) and filled prior to its installation in the water.

The structure (2) can be made positively buoyant or of reduced submerged unit weight, by adjusting the volume of the microspheres (3) in the enclosure (1) or by adding a liquid to fill the surrounding voids. The structure can then be towed to its installation site by an appropriate towing method for installation.

The ceramic microspheres (3) are preferably alumina silicate and have a preferred particle specific gravity of approximately 0.7. The microspheres have a bulk specific density less than that of water and which is preferably in the range of 0.37 to 0.8 g/cc when tightly packed with air contained in the void spaces between the microspheres (3). The preferred bulk specific density is in the range of 0.42 to 0.49 g/cc. The microspheres have a diameter in the region of 5 to 1000 microns, the actual particle size being selected according to the use of the invention.

The microspheres (3) are tightly packed to a density where, when submerged in use, the internal pressure on the microspheres is greater than or substantially equal to the water pressure on the structure (2). It is to be understood that where the structure is only partially submerged, the water pressure referred to is on the submerged part. The microspheres (3) entrained with gas or air in the enclosure (1), which is effectively impermeable to the surrounding water or air, thus prevent the compression and collapse of the enclosure (1) when subjected to external hydrostatic pressure from the surrounding water. The microspheres (3) themselves have a collapsing pressure beyond that to which they would be subjected by the surrounding water during installation.

It should be understood that the term "tightly packed" is used to mean that when the microspheres (3) are compressed, they exert pressure on the surrounding enclosure (1). If the compressive force is removed, the

microspheres (3) stay compacted and continue to exert pressure on the enclosure (1). It is believed that there is an internal pressure or stress exerted on the microspheres (3). After a certain pressure or compacted density is obtained, the microspheres (3) tend to act more like a solid and cease to flow. When compacted to behave like a solid, the microspheres (3) are capable of carrying the shear transmitting stress. It is in this way that the microspheres (3) assist in forming a compliant structure which is able to resist external pressure and to carry externally applied forces and moments. This feature is more relevant in the embodiments described below, where the enclosure (1) partially or completely surrounds the structure (2).

Although the microspheres are tightly packed when the structure is submerged in use, they may not be so tightly packed before submergence. This will obviously depend on the circumstances of use of the invention. However, once the apparatus or structure is submerged, the microspheres become tightly packed.

The voids between the microspheres (3) can be filled with a fluid, such as water, rather than air, in which case the buoyancy provided remains constant, irrespective of increases or decreases of externally applied pressure due to changes in water depth.

In an alternative embodiment of the invention illustrated in Figure 2, the buoyant enclosure (1) is provided by a compartment (4) which is a part of the structure (2) itself. Alternatively, as shown in Figure 3, the buoyant enclosure (1) can be located within a compartment (4) of the structure (2).

Referring now to Figures 4, 4a, 5 and 5a, the enclosure (1) is preferably shaped so as to partially or

completely surround the structure (2). The resultant structure is a compliant structure to which the packed microspheres (3) provide not only buoyancy, but also structural strength and protect the structure (2) from damage. The tightly packed microspheres (3) have the effect of increasing the collapse pressure of the enclosure (1) against, in particular, cylindrical collapse. The microspheres (3) when tightly packed into the enclosure (1) "grip", through friction, the structure (2) and thus hold it in position within the enclosure (1). This is particularly important where the structure (2) could be subjected to bending. Where the structure (2) is subjected to bending, the resulting shear stress is transferred across the enclosure (1) to the structure (2), and vice versa, helping to reduce or eliminate damage and buckling of the structure (2) inside. The buckling limit due to bending is increased by the use of the tightly packed microspheres (3) which thus maintain a uniform cross-section (particularly of the enclosure (1)) to a greater bending moment.

Water pressure will also serve to increase structural strength by causing further compaction of the microspheres (3). The internal surface of the enclosure (1) and the external surface of the structure (2) may also be coated to increase the friction factor.

These embodiments of the invention have a further additional advantage in that the enclosure (1) filled with microspheres (3) provides thermal insulation to the structure (2).

In order to further improve the thermal insulation, the void space around the microspheres (3) can be filled with a resin, polymer or other suitable bond setting material. Such a bonding material may be introduced as a liquid, which then sets to form with the microspheres a

consolidated material. Instead of filling the enclosure (1) first with spheres and then injecting the bond setting material, the mixing of microspheres and bonding liquid may be carried out prior to the filling of the enclosure (1). The resulting solid matrix helps strengthen the structure and also prevents convection around the microspheres and improves the thermal insulation. Alternatively the voids may be filled with fine particle solids, such as dry cement, corrosion inhibitor or talc. This helps to eliminate convection within the enclosure (1) and assists the thermal insulation. If dry cement is used, water can subsequently be added which causes the cement to set and harden. The cement also strengthens the structure and helps to minimise mechanical damage thereto. The internal surface of the enclosure (2) may be grooved, routed, roughened or provided with a friction coating to provide suitable keying for the bonding material or cement to further strengthen the enclosed structure (2). This also helps to increase the tensile and compressive strength of the overall structure, and also the shear strength.

The roughening, grooving, routing and friction coating can also be used in the embodiment of the invention utilising dry microspheres (3) as it helps to prevent movement of the microspheres (3).

In these embodiments of the invention, the material of the enclosure (1) can also be chosen to further improve the achievable thermal insulation. If desired, the structure (2) may also be coated with a thermal insulation material and/or an anti-corrosion material underneath the enclosure (1).

The enclosure (1) can be a simple sleeve, or in the form of, say, an annulus. In the latter example, the inner surface of the annulus can be bonded to the structure (2).

Referring now to Figures 6 and 7 there is shown a structure (2), being a pipeline T piece and a valve assembly respectively, surrounded by an enclosure (1) which is filled with tightly packed microspheres (3). The enclosures (1) are surrounded with an external cover (5) to prevent damage to the enclosure (1).

Obviously although only a single structure (2) is illustrated in the enclosure (1), the invention is equally applicable to a plurality of structures (2) in a single enclosure (1).

When installed, the structure (2) may be required to be joined end to end with a further structure (2a) by a welded connection (7), as shown in Figure 6, or a flanged or other mechanical connection. Each structure (2, 2a), such as two pipelines, is located within a surrounding enclosure (1). The enclosures (1) may either terminate short of each end of the respective structure, or alternatively, as illustrated in Figure 6, may be abutted and adjoined to an adjacent jacket (1a) following the welding of the structures (2, 2a).

End caps (6) may be used which circumferentially surround the structure (2), or an end thereof to create compartments within the enclosure (1). If desired, the end caps (6) may be secured to the structure (2, 2a) by a suitable adhesive and they may also be bonded to the enclosure (1), either by adhesive or by co-curing the enclosure (1) and the end cap (6) to form an integral assembly. Where a bonding material is to be introduced into the microsphere void space, the end caps (6) need only be temporary. The end caps may also feature holes, diaphragms or valves, where necessary, to assist with the filling of the enclosure (1).

The end caps (6) are made of a suitable rubber or plastic materials such as SBR, EPDM, polyethelene, polyvinalchloride, polyurethane, polyolefines or glassed reinforced resins. When the structure (2) is likely to be subjected to a high temperature, it is preferred that a heat resistant material is used for at least the radially inner part of each cap (6). The dimensions and materials from which the enclosure (1), cover (5), end cap (6) are fabricated will be chosen to suit the anticipated structure, operating temperature and other design requirements.

Referring to Figures 8 and 9, there is shown a structure made up of two pipes (2b, 2c) joined end to end by a welded connection (7). Each pipe (2b, 2c) is located within a surrounding elongated enclosure (1), which terminates short of each end of the respective pipe (2b, 2c). The enclosures (1) extend between end caps (6) which circumferentially surround the pipe (2b, 2c) similar to those mentioned above. Within the enclosure (1), the pipe (2b, 2c) is covered with a layer of thermally insulating material (8). The space between the pipe (2b, 2c) or the insulating layer (8) and the enclosure (1) contains tightly packed microspheres (3). To protect the welded region of the pipes (2b, 2c) between the enclosures (1), the region is wrapped with a suitable shrink wrap material (9). This is then be covered by two semi-cylindrical thermal insulation segments (10) which surround the pipe and are held in place by any suitable means such as adhesive or circumferential straps. Multiple cylindrical segments may be used. Alternatively, the welded region may simply be left exposed.

Figures 10 and 11 show a similar arrangement to that shown in Figures 8 and 9, except in that the enclosures (1) surrounding adjacent pipes (2b, 2c) are abutted following

the welding of the pipes (2b, 2c) and the application of a corrosion protective wrap thermal insulation layer (8a) to the welded region.

The enclosure (1) of Figures 8-11 may also have an optional external cover (5) which is either continuous or extends between the end caps (6).

It is also envisaged, as mentioned above, that the invention extends to cover the use of a single enclosure (1) surrounding a plurality of structures or groups of structures. This is particularly applicable where the structures are pipelines.

Where the pipeline is laid from a lay vessel, tension is applied to the pipeline by gripping the outside of the enclosure (1) which compresses the microspheres (3) which carry/transmit the shear force and thus tension to the enclosed pipeline. The pressure from the tension attracts increases the ability of the microspheres to transmit the shear force, but it also has a triaxial effect.

When a structure, such as a submarine pipeline made of a number of section of pipes, is to be installed, it is often necessary to include a number of joints, say every 12 or 24 metres. These may be joints as described above or a combination of the features described previously. In the application described in Figure 8, the shrink wrap (9) and thermal insulating segments (10) may be omitted. Figure 13 illustrates a field joint around a welded connection 7 in which a sheet steel wrap (11) is welded or affixed to the outside of the non-abutting enclosures (1) and the resulting cavity (12) between the pipes (2b, 2c) and sheet steel wrap (11) is filled with microspheres (3), either free filled or in a pre-filled and pre-shaped bag.

A particular problem associated with submarine pipelines is that they are susceptible to upheaval buckling, where compressive forces are induced in the pipeline when it is fully or partly restrained from expanding as the temperature of the pipeline is increased above the temperature at which it is installed. Although a compliant structural strength is provided by the tightly packed microspheres (3) and the weight of the pipeline helps to counteract bulk buckling, the susceptibility of the pipeline to such buckling can be further minimised or eliminated by first tensioning the pipe by the application of a force at each end thereof, surrounding the pipeline with the enclosure (1) and filling the enclosure (1) with the microspheres (3) and/or microspheres (3) and bonding liquid or compound as described above. The tensile force must be applied to a sufficient magnitude and held for a sufficient time to permit the bonding liquid or compound to set and harden and bond to the pipe or group of pipes. When the applied force has been released the pipe will be prevented from contracting, thus locking in tensile stress into the pipe. In an alternative method, the pipe may first be heated to a predetermined temperature which gives rise to thermal expansion, before being surrounded by the enclosure (1) and microspheres (3) with the bonding liquid or compound. The temperature should be maintained for sufficient time to permit the bonding liquid or compound to set and harden and bond the pipe. When the pipe is allowed to cool, the pipe will be prevented from contracting.

When pretensioning structures containing dry microspheres, the microspheres must be compacted to an appropriate pressure first.

Where the pipeline is of a significant length, thermal strain resisting bulkheads should be included, say every 200 metres. These may be as illustrated in Figure

12. Alternatively, the solid steel sleeve may be replaced by a two part sleeve, the parts of which are separated by thermal insulation to minimise the heat loss therefrom.

The microspheres (3) may be introduced into the enclosure (1) in a manner as shown in Figure 14. The microspheres (3) are entrained in a gas, such as air, or a liquid, such as water, which is utilised as a transmission medium and injected with a suitable pipe means (15) into the enclosure (1). In the case of gas, this may be allowed to escape from a vent valve or plurality of vent valves (16) suitably located in the enclosure (1). The vent valves (16) should be designed so as to allow the expulsion of the gas, but not the microspheres (3). In the case of a liquid, such as water, this may be allowed to escape from one or more orifices (17) located in the base of the enclosure (1) or another suitable location. This venting can be used to control the buoyancy of the structure (2).

Although in the embodiments of the invention described previously the enclosure (1) has been filled with the microspheres (3) prior to towing or installation, in certain other embodiments of the invention it is preferable to effect the filling of the enclosure (1) after the structure (2) has been towed to an appropriate installation site and prior to submergence. Alternatively, the structure (2) may first be submerged and then the enclosure (1) filled with the microspheres (3). In some cases the microspheres (3) are just introduced into sections of the enclosure (1) or along the entire length of the structure (2). Obviously the order of towing, filling and submerging will depend on the design of the structure (2), whether it is positively or negatively buoyant without the microspheres (3) and whether the microspheres (3) are required to help to regulate the buoyancy or just to provide the thermal insulation and/or structural strength benefit.

Where the recovery of equipment is required, an enclosure (1) may be attached or inserted into the structure (2) which is then provided with sufficient buoyancy to be raised and towed. It may be necessary, depending on the application of the structure (2) to first separate previously joined pieces of the structure.

It is to be understood that the use of the terms "submarine" and "marine" do not just apply to sea applications. The invention also applies to apparatus which can be used in lakes, estuaries, shore approaches and the like. The submarine pipelines referred to can be water pipelines, fuel supply lines, chemical lines and the like.

CLAIMS:-

1. Marine or submarine apparatus comprising an impermeable enclosure associated with said apparatus, which enclosure is tightly packed with hollow microspheres to a density where, when submerged in use, the internal pressure on the microspheres is greater than or substantially equal to the water pressure on the apparatus.
2. Marine or submarine apparatus as claimed in claim 1 in which the microspheres are of a ceramic material.
3. Marine or submarine apparatus as claimed in claim 1 or claim 2 in which the microspheres have a particle diameter in the range 5 to 1000 microns.
4. Marine or submarine apparatus as claimed in any one of the preceding claims in which the bulk specific density of the microspheres is less than or equal to that of water.
5. Marine or submarine apparatus as claimed in any one of the preceding claims in which the bulk specific density of the packed microspheres lies in the range of 0.37 to 0.8 g/cc.
6. Marine or submarine apparatus as claimed in claim 5 in which the bulk specific density of the packed microspheres is in the range of 0.42 to 0.49 g/cc.
7. Marine or submarine apparatus as claimed in any one of the preceding claims in which voids formed between the microspheres are filled with fine particle solids.
8. Marine or submarine apparatus as claimed in any one of the preceding claims 1 to 6 in which voids formed between the microspheres are filled with a solid matrix.

9. Marine or submarine apparatus as claimed in any one of claims 1 to 6 in which voids formed between the microspheres are filled with a vacuum, gas or liquid.
10. Marine or submarine apparatus as claimed in any one of the preceding claims in which the enclosure is of a rigid or flexible material.
11. Marine or submarine apparatus as claimed in any one of the preceding claims in which the enclosure is of a thermally insulating material.
12. Marine or submarine apparatus as claimed in any one of the preceding claims in which the apparatus is coated with a thermal insulation layer.
13. Marine or submarine apparatus as claimed in any one of the preceding claims in which the enclosure wholly or partially surrounds the apparatus with a space therebetween, which space is filled with the microspheres.
14. Marine or submarine apparatus as claimed in any one of the preceding claims in which the enclosure is attached to an external surface of the apparatus.
15. Marine or submarine apparatus as claimed in any one of claims 1 to 12 in which the enclosure is located within the apparatus.
16. Marine or submarine apparatus as claimed in any one of claims 1 to 12 and 15 in which the enclosure forms a part of the structure of the apparatus.
17. Marine or submarine apparatus as claimed in any one of the preceding claims in which the enclosure is surrounded by an external cover.

18. Marine or submarine apparatus as claimed in any one of the preceding claims in which the enclosure comprises a jacket for surrounding the apparatus and end caps to close one or more ends of the jacket.
19. Marine or submarine apparatus as claimed in any one of the preceding claims further including end caps for creating compartments within the enclosure.
20. A submarine flowline comprising a pipeline, a group of pipelines, or combination of pipeline(s) and associated equipment located within an impermeable enclosure with a space between said enclosure and flowline, which space is filled with tightly packed microspheres to a density where, when submerged in use, the internal pressure on the microspheres is greater than or substantially equal to the external water pressure on the flowline.
21. A submarine flowline as claimed in claim 20 further comprising joints and/or thermal strain resisting bulkheads at intervals along the flowline.
22. A method of installing or recovering marine or submarine apparatus comprising the step of filling an enclosure associated with said apparatus with tightly packed microspheres to a density where, when submerged in use, the internal pressure on the microspheres is greater than or substantially equal to the water pressure on the apparatus.
23. A method as claimed in claim 22 further comprising the step of filling voids formed between the microspheres with fine solid particles.
24. A method as claimed in claim 22 or claim 23 further comprising the step of further filling the enclosure with a liquid.

25. A method as claimed in any one of claims 22 to 24 comprising the step of further filling the enclosure with a fluid which sets or reacts with another material to set to form a solid matrix around the microspheres.
26. A method as claimed in claim 22 in which the microspheres are mixed with a settable material prior to filling the enclosure.
27. A method as claimed in claim 22 further comprising the step of filling voids formed between the microspheres with a gas or evacuating said voids.
28. A method as claimed in any one of claims 22 to 27 further comprising the step of towing the apparatus to or from an offshore location.
29. A method as claimed in any one of claims 22 to 28 further comprising the step of joining separate pieces of apparatus and their enclosures.
30. A method as claimed in any one of claims 22 to 28 further comprising the step of separating joined pieces of apparatus.
31. A method as claimed in any one of claims 22 to 30 further comprising the step of first surrounding the apparatus with the enclosure.
32. A method as claimed in any one of claims 22 to 31 further comprising the step of applying a tensile stress to the apparatus before surrounding the apparatus with the enclosure.
33. A method as claimed in any one of claims 22 to 32 further comprising the step of heating the apparatus before surrounding it with the enclosure.

34. A method as claimed in any one of claims 22 to 33 further comprising the step of venting gas or a liquid from the enclosure to control the buoyancy of the apparatus.

FIG. 1.

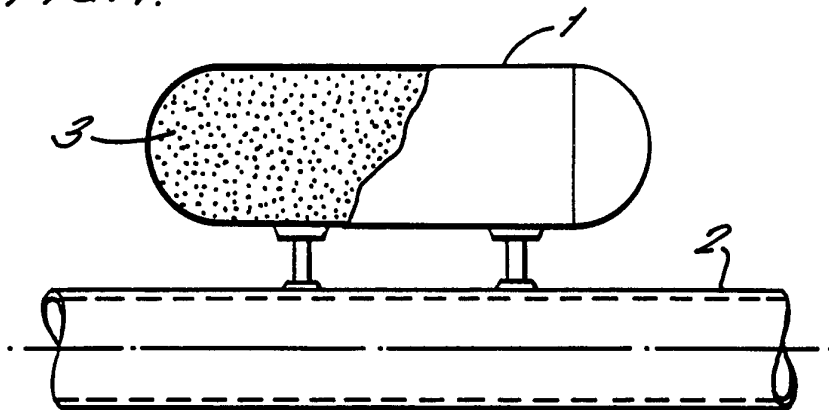

FIG. 2.

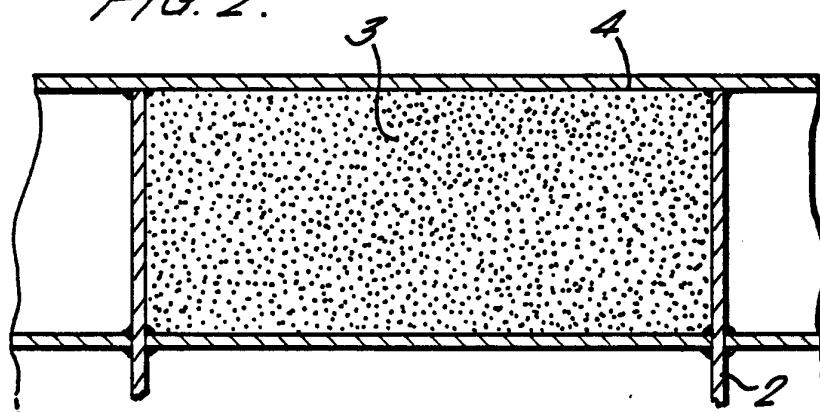

FIG. 3.

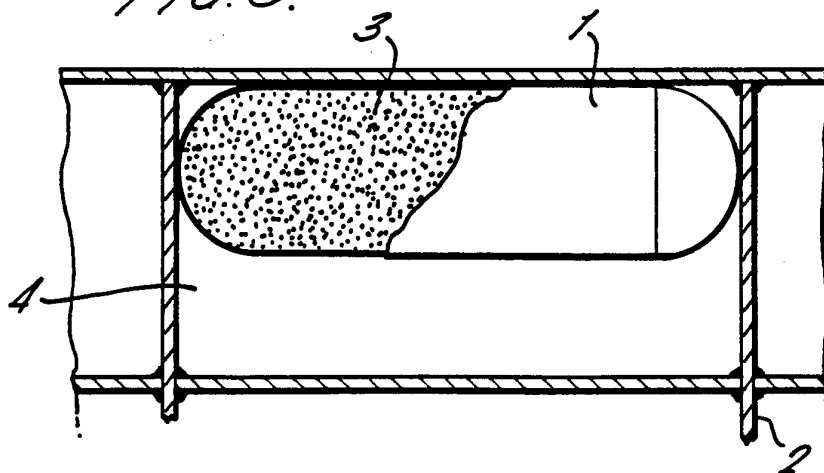

FIG. 4.

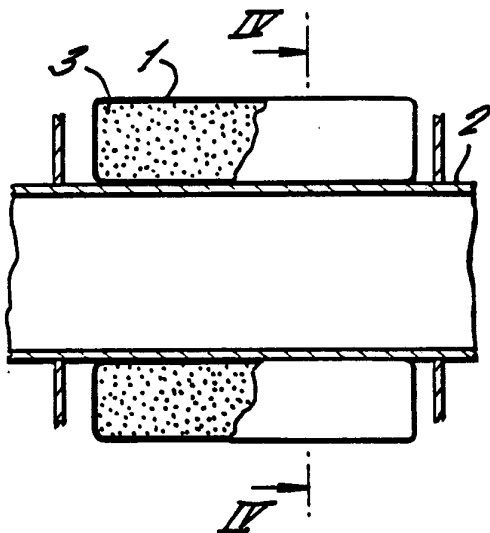

FIG. 4a.

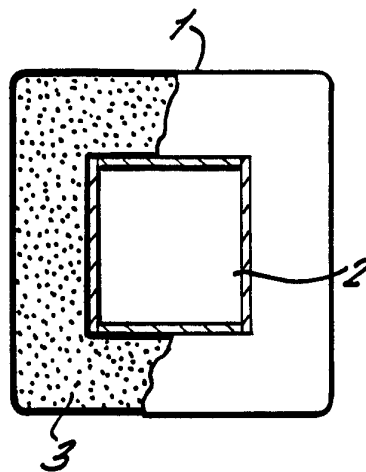

FIG. 5.

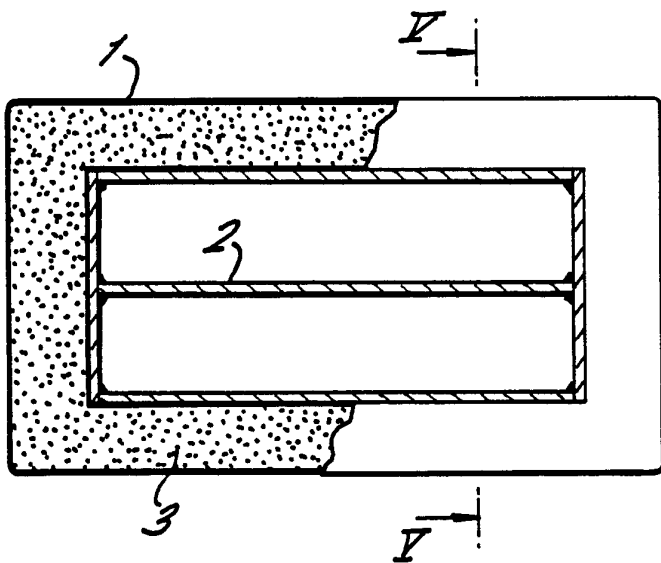

FIG. 5a.

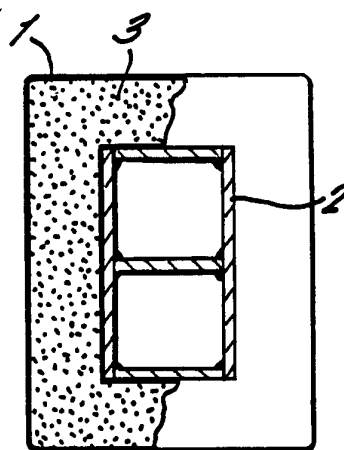

FIG. 6.

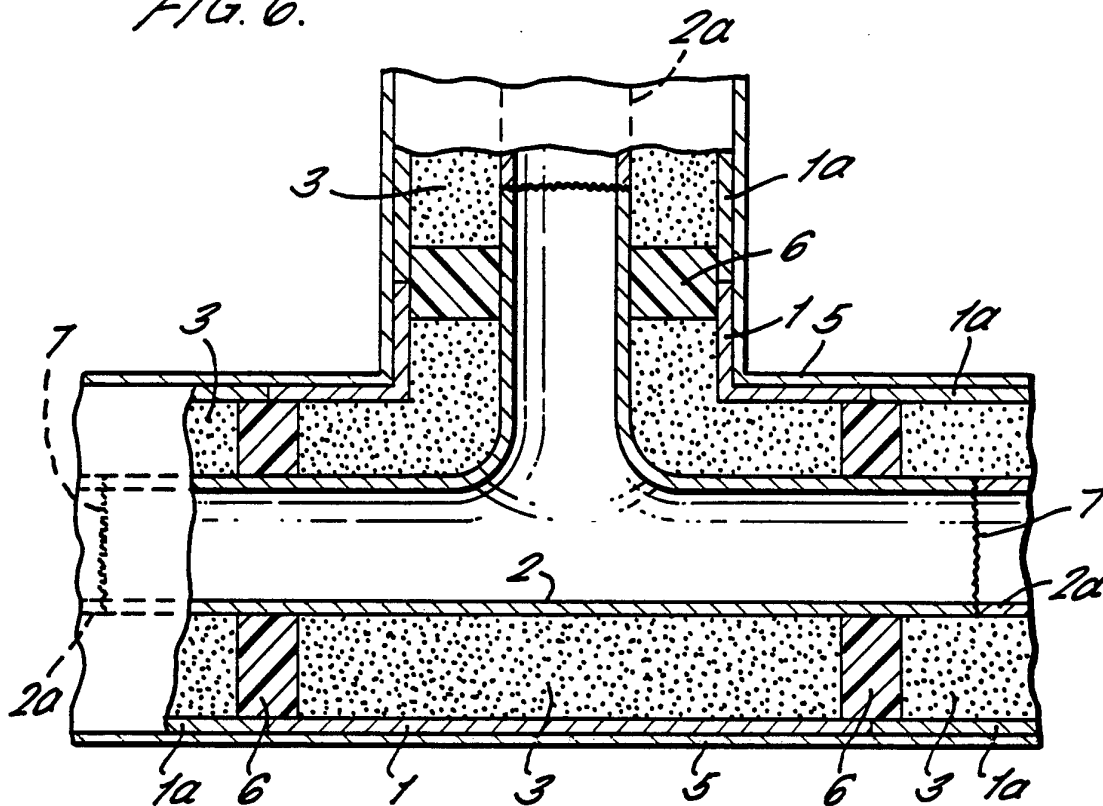

FIG. 7.

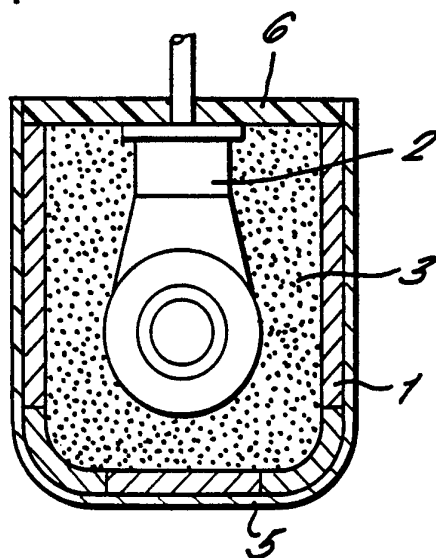

FIG. 8.

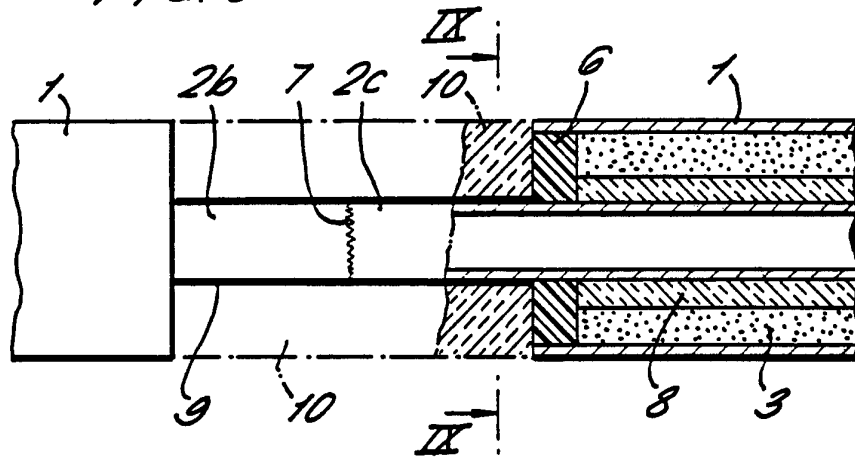

FIG. 9.

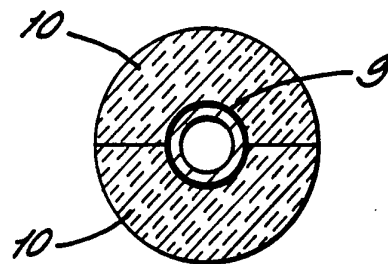

FIG. 10.

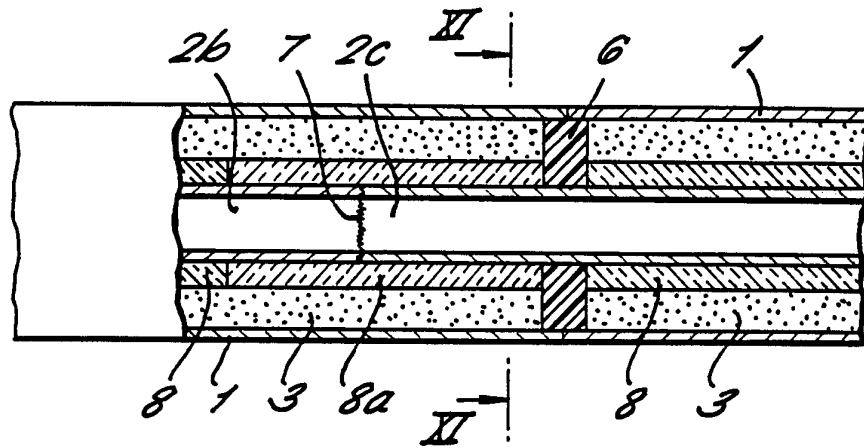

FIG. 11.

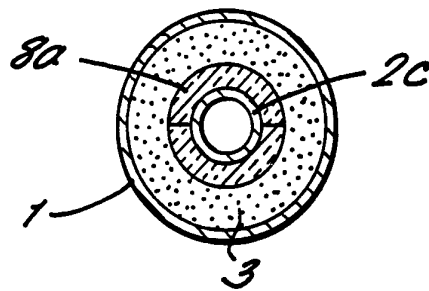

FIG. 12.

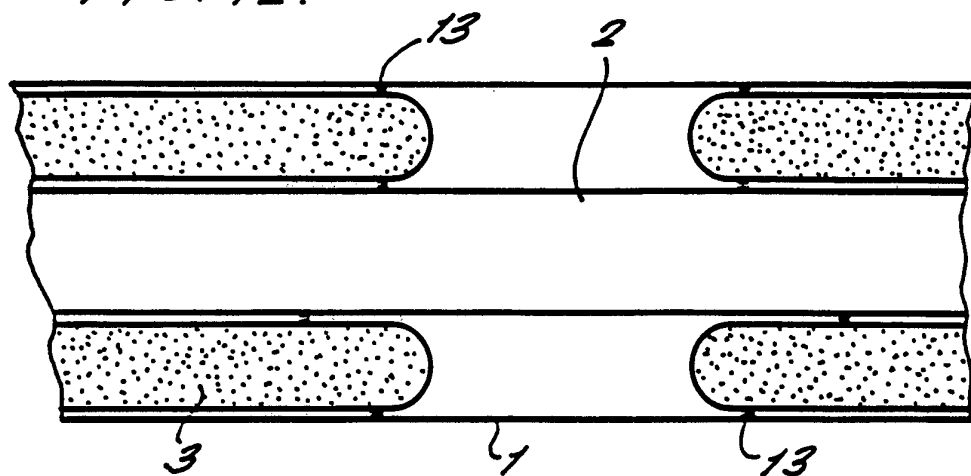

FIG. 13.

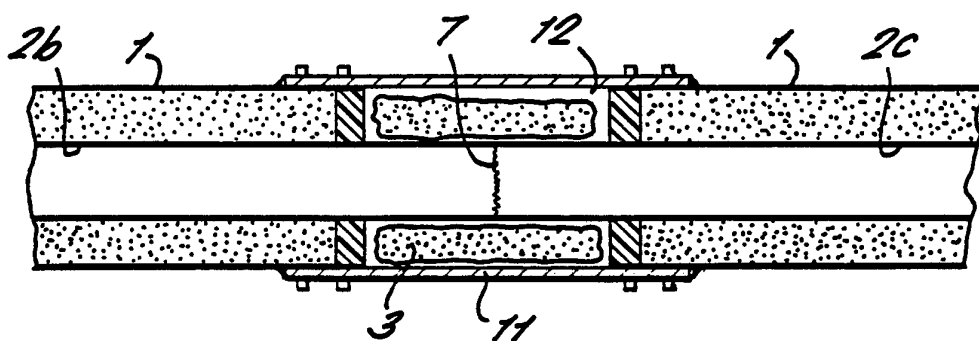
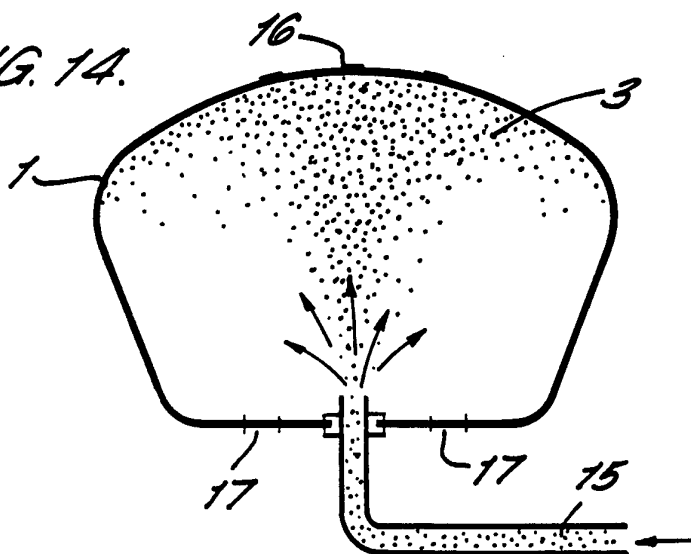

FIG. 14.



INTERNATIONAL SEARCH REPORT

Intern: Application No
PCT/GB 93/01693

| <p>A. CLASSIFICATION OF SUBJECT MATTER IPC 5 F16L59/14 F16L11/133 F16L11/12</p> <p>According to International Patent Classification (IPC) or to both national classification and IPC</p> | | | | | | | | | | | | | | | | | |
|--|--|---|------------|--|-----------------------|---|--|---|---|--------------|------|-----|---------------------------------------|---|---|------------------------|--------------------|
| <p>B. FIELDS SEARCHED</p> <p>Minimum documentation searched (classification system followed by classification symbols) IPC 5 F16L</p> <p>Documentation searched other than minimum documentation to the extent that such documents are included in the fields searched</p> <p>Electronic data base consulted during the international search (name of data base and, where practical, search terms used)</p> | | | | | | | | | | | | | | | | | |
| <p>C. DOCUMENTS CONSIDERED TO BE RELEVANT</p> <table border="1"> <thead> <tr> <th>Category °</th> <th>Citation of document, with indication, where appropriate, of the relevant passages</th> <th>Relevant to claim No.</th> </tr> </thead> <tbody> <tr> <td>X</td> <td>US,A,3 935 632 (MAXON) 3 February 1976</td> <td>1-3, 8, 10-13, 16-19, 22, 25, 28</td> </tr> <tr> <td>A</td> <td>see abstract</td> <td>5, 6</td> </tr> <tr> <td>X,P</td> <td>EP,A,0 521 582 (SHELL) 7 January 1993</td> <td>1, 2, 8-11, 13, 14, 17-20, 22, 24, 25, 27, 28, 31</td> </tr> <tr> <td>A</td> <td>see the whole document</td> <td>4-6, 12, 15, 16</td> </tr> </tbody> </table> | | | Category ° | Citation of document, with indication, where appropriate, of the relevant passages | Relevant to claim No. | X | US,A,3 935 632 (MAXON) 3 February 1976 | 1-3, 8, 10-13, 16-19, 22, 25, 28 | A | see abstract | 5, 6 | X,P | EP,A,0 521 582 (SHELL) 7 January 1993 | 1, 2, 8-11, 13, 14, 17-20, 22, 24, 25, 27, 28, 31 | A | see the whole document | 4-6, 12, 15, 16 |
| Category ° | Citation of document, with indication, where appropriate, of the relevant passages | Relevant to claim No. | | | | | | | | | | | | | | | |
| X | US,A,3 935 632 (MAXON) 3 February 1976 | 1-3, 8, 10-13, 16-19, 22, 25, 28 | | | | | | | | | | | | | | | |
| A | see abstract | 5, 6 | | | | | | | | | | | | | | | |
| X,P | EP,A,0 521 582 (SHELL) 7 January 1993 | 1, 2, 8-11, 13, 14, 17-20, 22, 24, 25, 27, 28, 31 | | | | | | | | | | | | | | | |
| A | see the whole document | 4-6, 12, 15, 16 | | | | | | | | | | | | | | | |
| <p><input checked="" type="checkbox"/> Further documents are listed in the continuation of box C. <input checked="" type="checkbox"/> Patent family members are listed in annex.</p> | | | | | | | | | | | | | | | | | |
| <p>° Special categories of cited documents :</p> <p>"A" document defining the general state of the art which is not considered to be of particular relevance</p> <p>"E" earlier document but published on or after the international filing date</p> <p>"L" document which may throw doubts on priority claim(s) or which is cited to establish the publication date of another citation or other special reason (as specified)</p> <p>"O" document referring to an oral disclosure, use, exhibition or other means</p> <p>"P" document published prior to the international filing date but later than the priority date claimed</p> <p>"T" later document published after the international filing date or priority date and not in conflict with the application but cited to understand the principle or theory underlying the invention</p> <p>"X" document of particular relevance; the claimed invention cannot be considered novel or cannot be considered to involve an inventive step when the document is taken alone</p> <p>"Y" document of particular relevance; the claimed invention cannot be considered to involve an inventive step when the document is combined with one or more other such documents, such combination being obvious to a person skilled in the art.</p> <p>"&" document member of the same patent family</p> | | | | | | | | | | | | | | | | | |
| <p>Date of the actual completion of the international search</p> <p>27 October 1993</p> | | <p>Date of mailing of the international search report</p> <p>01.12.93</p> | | | | | | | | | | | | | | | |
| <p>Name and mailing address of the ISA</p> <p>European Patent Office, P.B. 5818 Patentlaan 2 NL - 2280 HV Rijswijk Tel. (+ 31-70) 340-2040, Tx. 31 651 epo nl, Fax (+ 31-70) 340-3016</p> | | <p>Authorized officer</p> <p>ANGIUS, P</p> | | | | | | | | | | | | | | | |

INTERNATIONAL SEARCH REPORT

Intern al Application No

PCT/GB 93/01693

| C.(Continuation) DOCUMENTS CONSIDERED TO BE RELEVANT | | |
|--|---|--|
| Category ° | Citation of document, with indication, where appropriate, of the relevant passages | Relevant to claim No. |
| X | FR,A,2 598 713 (INSTITUT FRANCAIS DU PETROLE) 20 November 1987 | 1-4,7,8, 10,11, 13,14, 17, 20-23, 25,31 |
| A | see abstract; claims 1-6; figures 1-3 | 5,6,12, 15,16,28 |
| A | --- GB,A,2 106 093 (THE SECRETARY OF STATE FOR DEFENCE) 7 April 1983 see abstract | 1,2,4,5 |
| A | --- US,A,3 407 835 (ROLFES) 29 October 1968 see figures 1-10 ----- | 29 |

INTERNATIONAL SEARCH REPORT

information on patent family members

Interr. al Application No

PCT/GB 93/01693

| Patent document cited in search report | Publication date | Patent family member(s) | Publication date |
|--|------------------|--|--|
| US-A-3935632 | 03-02-76 | CA-A- 1035919 GB-A- 1441208 | 08-08-78 30-06-76 |
| EP-A-0521582 | 07-01-93 | NONE | |
| FR-A-2598713 | 20-11-87 | EP-A,B 0250278 JP-A- 62283139 US-A- 4963420 US-A- 5218016 | 23-12-87 09-12-87 16-10-90 08-06-93 |
| GB-A-2106093 | 07-04-83 | NONE | |
| US-A-3407835 | | NONE | |