



(12) **DEMANDE DE BREVET CANADIEN
CANADIAN PATENT APPLICATION**

(13) **A1**

(86) Date de dépôt PCT/PCT Filing Date: 2019/12/30
 (87) Date publication PCT/PCT Publication Date: 2020/07/09
 (85) Entrée phase nationale/National Entry: 2020/12/10
 (86) N° demande PCT/PCT Application No.: US 2019/068982
 (87) N° publication PCT/PCT Publication No.: 2020/142452
 (30) Priorité/Priority: 2018/12/31 (US62/786,799)

(51) Cl.Int./Int.Cl. *A47C 31/00* (2006.01),
A47C 27/08 (2006.01), *A47C 27/10* (2006.01)
 (71) Demandeur/Applicant:
SLEEP NUMBER CORPORATION, US
 (72) Inventeurs/Inventors:
SAYADI, OMID, US;
SIYAHJANI, FARZAD, US
 (74) Agent: BERESKIN & PARR LLP/S.E.N.C.R.L.,S.R.L.

(54) Titre : DOMOTIQUE A CARACTERISTIQUES D'AMELIORATION DU SOMMEIL
 (54) Title: HOME AUTOMATION WITH FEATURES TO IMPROVE SLEEP

1900 ↘

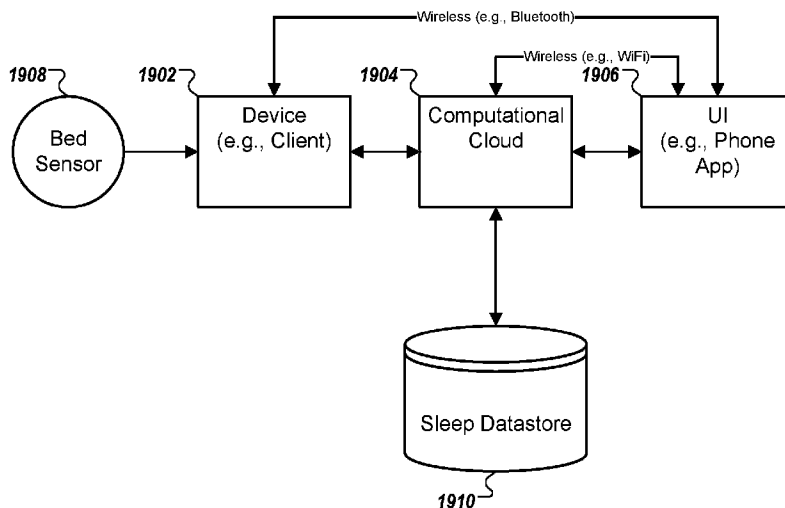

FIG. 19

(57) **Abrégé/Abstract:**

A bed has a mattress. A sensor is configured to sense sleep readings of a user sleeping on the bed. An automation controller is configured to transmit the sleep readings to a cloud service. Hardware hosting the cloud service is configured to compare the sleep readings with trend data in order to generate adjustments to the user's sleep environment.

(12) INTERNATIONAL APPLICATION PUBLISHED UNDER THE PATENT COOPERATION TREATY (PCT)

(19) World Intellectual Property Organization
International Bureau

(43) International Publication Date
09 July 2020 (09.07.2020)



(10) International Publication Number
WO 2020/142452 A1

- (51) **International Patent Classification:**
A47C 31/00 (2006.01) A47C 27/10 (2006.01)
A47C 27/08 (2006.01)
- (21) **International Application Number:**
PCT/US2019/068982
- (22) **International Filing Date:**
30 December 2019 (30.12.2019)
- (25) **Filing Language:** English
- (26) **Publication Language:** English
- (30) **Priority Data:**
62/786,799 31 December 2018 (31.12.2018) US
- (71) **Applicant: SLEEP NUMBER CORPORATION** [US/US]; 1001 Third Avenue South, Minneapolis, Minnesota 55404 (US).
- (72) **Inventors: SAYADI, Omid;** 7024 Via Anacapa, San Jose, California 95139 (US). **SIYAHJANI, Farzad;** 2095 Scott BLVD APT 1, Santa Clara, California 95050 (US).
- (74) **Agent: NELSON, Stuart A.;** Fish & Richardson P.C., P.O. Box 1022, Minneapolis, Minnesota 55440-1022 (US).
- (81) **Designated States** (unless otherwise indicated, for every kind of national protection available): AE, AG, AL, AM, AO, AT, AU, AZ, BA, BB, BG, BH, BN, BR, BW, BY, BZ, CA, CH, CL, CN, CO, CR, CU, CZ, DE, DJ, DK, DM, DO, DZ, EC, EE, EG, ES, FI, GB, GD, GE, GH, GM, GT, HN, HR, HU, ID, IL, IN, IR, IS, JO, JP, KE, KG, KH, KN, KP, KR, KW, KZ, LA, LC, LK, LR, LS, LU, LY, MA, MD, ME, MG, MK, MN, MW, MX, MY, MZ, NA, NG, NI, NO, NZ, OM, PA, PE, PG, PH, PL, PT, QA, RO, RS, RU, RW, SA, SC, SD, SE, SG, SK, SL, SM, ST, SV, SY, TH, TJ, TM, TN, TR, TT, TZ, UA, UG, US, UZ, VC, VN, ZA, ZM, ZW.
- (84) **Designated States** (unless otherwise indicated, for every kind of regional protection available): ARIPO (BW, GH, GM, KE, LR, LS, MW, MZ, NA, RW, SD, SL, ST, SZ, TZ, UG, ZM, ZW), Eurasian (AM, AZ, BY, KG, KZ, RU, TJ, TM), European (AL, AT, BE, BG, CH, CY, CZ, DE, DK, EE, ES, FI, FR, GB, GR, HR, HU, IE, IS, IT, LT, LU, LV, MC, MK, MT, NL, NO, PL, PT, RO, RS, SE, SI, SK, SM,

(54) **Title:** HOME AUTOMATION WITH FEATURES TO IMPROVE SLEEP

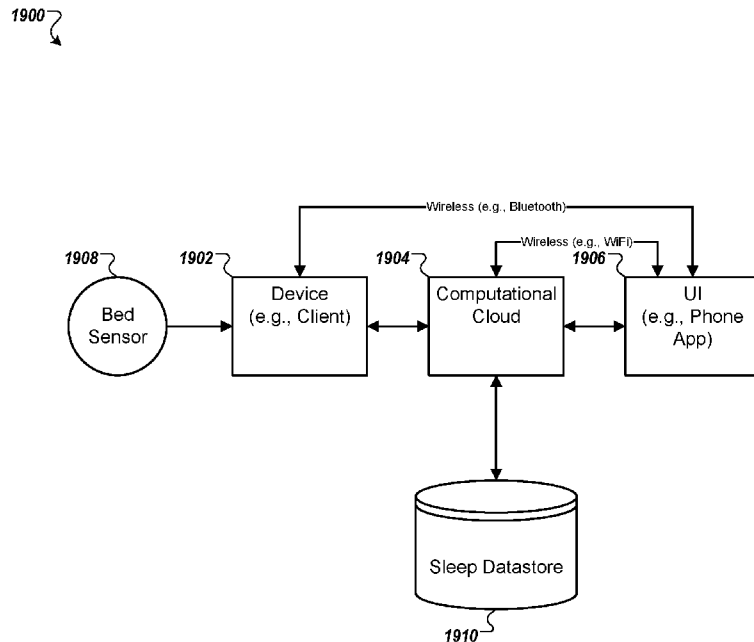

FIG. 19

(57) **Abstract:** A bed has a mattress. A sensor is configured to sense sleep readings of a user sleeping on the bed. An automation controller is configured to transmit the sleep readings to a cloud service. Hardware hosting the cloud service is configured to compare the sleep readings with trend data in order to generate adjustments to the user's sleep environment.



WO 2020/142452 A1

WO 2020/142452 A1 

TR), OAPI (BF, BJ, CF, CG, CI, CM, GA, GN, GQ, GW,
KM, ML, MR, NE, SN, TD, TG).

Declarations under Rule 4.17:

- *as to applicant's entitlement to apply for and be granted a patent (Rule 4.17(ii))*
- *as to the applicant's entitlement to claim the priority of the earlier application (Rule 4.17(iii))*

Published:

- *with international search report (Art. 21(3))*

HOME AUTOMATION WITH FEATURES TO IMPROVE SLEEP

CROSS-REFERENCE TO RELATED APPLICATION

This application claims the benefit of U.S. Provisional Application No. 62/786,799, filed on December 31, 2018, which is incorporated by reference herein in its entirety.

[0001] The present document relates to automation of a consumer device such as an airbed.

BACKGROUND

[0002] In general, a bed is a piece of furniture used as a location to sleep or relax. Many modern beds include a soft mattress on a bed frame. The mattress may include springs, foam material, and/or an air chamber to support the weight of one or more occupants.

SUMMARY

[0003] Technology described in this document advances the state of home automation and sleep devices. For example, personalized, population based, and subpopulation analysis of sleep data can be used to generate personalized automation and recommendations for a user. This can produce technology that provides a user with human-readable information about their sleep with actionable information that is particularly and specifically crafted based on actual interactions the user has with her environment. In addition, automation of the user's environment can be carried out in the same sleep session in which problems are found that could potentially have a negative impact on the user's sleep otherwise.

[0004] Other features, aspects and potential advantages will be apparent from the accompanying description and figures.

DESCRIPTION OF DRAWINGS

[0005] FIG. 1 shows an example air bed system.

- [0006] FIG. 2 is a block diagram of an example of various components of an air bed system.
- [0007] FIG. 3 shows an example environment including a bed in communication with devices located in and around a home.
- [0008] FIGs. 4A and 4B are block diagrams of example data processing systems that can be associated with a bed.
- [0009] FIGs. 5 and 6 are block diagrams of examples of motherboards that can be used in a data processing system that can be associated with a bed.
- [0010] FIG. 7 is a block diagram of an example of a daughterboard that can be used in a data processing system that can be associated with a bed.
- [0011] FIG. 8 is a block diagram of an example of a motherboard with no daughterboard that can be used in a data processing system that can be associated with a bed.
- [0012] FIG. 9 is a block diagram of an example of a sensory array that can be used in a data processing system that can be associated with a bed.
- [0013] FIG. 10 is a block diagram of an example of a control array that can be used in a data processing system that can be associated with a bed.
- [0014] FIG. 11 is a block diagram of an example of a computing device that can be used in a data processing system that can be associated with a bed.
- [0015] FIGs. 12-16 are block diagrams of example cloud services that can be used in a data processing system that can be associated with a bed.
- [0016] FIG. 17 is a block diagram of an example of using a data processing system that can be associated with a bed to automate peripherals around the bed.
- [0017] FIG. 18 is a schematic diagram that shows an example of a computing device and a mobile computing device.
- [0018] FIG. 19 is block diagram of an example system for home automation.
- [0019] FIG. 20 is a block diagram of an example system for home automation.
- [0020] FIG. 21 is a flowchart of an example process for processing data.
- [0021] FIG. 22 is a block diagram of an example process for processing data.
- [0022] FIG. 23 is a block diagram of an example process for processing data.

- [0023] FIG. 24 is a flowchart of an example process for receiving and sending data.
- [0024] FIG. 25 is a flowchart of an example process for receiving and sending data.
- [0025] FIG. 26 is a flowchart of an example process for home automation.
- [0026] FIG. 27 is a flowchart of an example process for home automation.
- [0027] FIG. 28 is a flowchart of an example process for control of a graphic user interface.
- [0028] FIG. 29 is an example of a graphical user interface.
- [0029] Like reference symbols in the various drawings indicate like elements.

DETAILED DESCRIPTION

[0030] This document describes technology related to sleep monitoring. An individual person's sleep can be enhanced with text-based suggestions and automated actuations that are shown via machine-learning to lead either a population or an individual to have more, better sleep

[0031] Example Airbed Hardware

[0032] FIG. 1 shows an example air bed system 100 that includes a bed 112. The bed 112 includes at least one air chamber 114 surrounded by a resilient border 116 and encapsulated by bed ticking 118. The resilient border 116 can comprise any suitable material, such as foam.

[0033] As illustrated in FIG. 1, the bed 112 can be a two chamber design having first and second fluid chambers, such as a first air chamber 114A and a second air chamber 114B. In alternative embodiments, the bed 112 can include chambers for use with fluids other than air that are suitable for the application. In some embodiments, such as single beds or kids' beds, the bed 112 can include a single air chamber 114A or 114B or multiple air chambers 114A and 114B. First and second air chambers 114A and 114B can be in fluid communication with a pump 120. The pump 120 can be in electrical communication with a remote control 122 via control box 124. The control box 124 can include a wired or wireless communications interface for communicating with one or more devices, including the remote control 122. The control box 124 can be configured

to operate the pump 120 to cause increases and decreases in the fluid pressure of the first and second air chambers 114A and 114B based upon commands input by a user using the remote control 122. In some implementations, the control box 124 is integrated into a housing of the pump 120.

[0034] The remote control 122 can include a display 126, an output selecting mechanism 128, a pressure increase button 129, and a pressure decrease button 130. The output selecting mechanism 128 can allow the user to switch air flow generated by the pump 120 between the first and second air chambers 114A and 114B, thus enabling control of multiple air chambers with a single remote control 122 and a single pump 120. For example, the output selecting mechanism 128 can be a physical control (e.g., switch or button) or an input control displayed on display 126. Alternatively, separate remote control units can be provided for each air chamber and can each include the ability to control multiple air chambers. Pressure increase and decrease buttons 129 and 130 can allow a user to increase or decrease the pressure, respectively, in the air chamber selected with the output selecting mechanism 128. Adjusting the pressure within the selected air chamber can cause a corresponding adjustment to the firmness of the respective air chamber. In some embodiments, the remote control 122 can be omitted or modified as appropriate for an application. For example, in some embodiments the bed 112 can be controlled by a computer, tablet, smart phone, or other device in wired or wireless communication with the bed 112.

[0035] FIG. 2 is a block diagram of an example of various components of an air bed system. For example, these components can be used in the example air bed system 100. As shown in FIG. 2, the control box 124 can include a power supply 134, a processor 136, a memory 137, a switching mechanism 138, and an analog to digital (A/D) converter 140. The switching mechanism 138 can be, for example, a relay or a solid state switch. In some implementations, the switching mechanism 138 can be located in the pump 120 rather than the control box 124.

[0036] The pump 120 and the remote control 122 are in two-way communication with the control box 124. The pump 120 includes a motor 142, a pump manifold 143, a relief valve 144, a first control valve 145A, a second control valve 145B, and a pressure transducer 146. The pump 120 is fluidly connected with the first air chamber 114A and

the second air chamber 114B via a first tube 148A and a second tube 148B, respectively. The first and second control valves 145A and 145B can be controlled by switching mechanism 138, and are operable to regulate the flow of fluid between the pump 120 and first and second air chambers 114A and 114B, respectively.

[0037] In some implementations, the pump 120 and the control box 124 can be provided and packaged as a single unit. In some alternative implementations, the pump 120 and the control box 124 can be provided as physically separate units. In some implementations, the control box 124, the pump 120, or both are integrated within or otherwise contained within a bed frame or bed support structure that supports the bed 112. In some implementations, the control box 124, the pump 120, or both are located outside of a bed frame or bed support structure (as shown in the example in FIG. 1).

[0038] The example air bed system 100 depicted in FIG. 2 includes the two air chambers 114A and 114B and the single pump 120. However, other implementations can include an air bed system having two or more air chambers and one or more pumps incorporated into the air bed system to control the air chambers. For example, a separate pump can be associated with each air chamber of the air bed system or a pump can be associated with multiple chambers of the air bed system. Separate pumps can allow each air chamber to be inflated or deflated independently and simultaneously. Furthermore, additional pressure transducers can also be incorporated into the air bed system such that, for example, a separate pressure transducer can be associated with each air chamber.

[0039] In use, the processor 136 can, for example, send a decrease pressure command to one of air chambers 114A or 114B, and the switching mechanism 138 can be used to convert the low voltage command signals sent by the processor 136 to higher operating voltages sufficient to operate the relief valve 144 of the pump 120 and open the control valve 145A or 145B. Opening the relief valve 144 can allow air to escape from the air chamber 114A or 114B through the respective air tube 148A or 148B. During deflation, the pressure transducer 146 can send pressure readings to the processor 136 via the A/D converter 140. The A/D converter 140 can receive analog information from pressure transducer 146 and can convert the analog information to digital information useable by the processor 136. The processor 136 can send the digital signal to the remote

control 122 to update the display 126 in order to convey the pressure information to the user.

[0040] As another example, the processor 136 can send an increase pressure command. The pump motor 142 can be energized in response to the increase pressure command and send air to the designated one of the air chambers 114A or 114B through the air tube 148A or 148B via electronically operating the corresponding valve 145A or 145B. While air is being delivered to the designated air chamber 114A or 114B in order to increase the firmness of the chamber, the pressure transducer 146 can sense pressure within the pump manifold 143. Again, the pressure transducer 146 can send pressure readings to the processor 136 via the A/D converter 140. The processor 136 can use the information received from the A/D converter 140 to determine the difference between the actual pressure in air chamber 114A or 114B and the desired pressure. The processor 136 can send the digital signal to the remote control 122 to update display 126 in order to convey the pressure information to the user.

[0041] Generally speaking, during an inflation or deflation process, the pressure sensed within the pump manifold 143 can provide an approximation of the pressure within the respective air chamber that is in fluid communication with the pump manifold 143. An example method of obtaining a pump manifold pressure reading that is substantially equivalent to the actual pressure within an air chamber includes turning off pump 120, allowing the pressure within the air chamber 114A or 114B and the pump manifold 143 to equalize, and then sensing the pressure within the pump manifold 143 with the pressure transducer 146. Thus, providing a sufficient amount of time to allow the pressures within the pump manifold 143 and chamber 114A or 114B to equalize can result in pressure readings that are accurate approximations of the actual pressure within air chamber 114A or 114B. In some implementations, the pressure of the air chambers 114A and/or 114B can be continuously monitored using multiple pressure sensors (not shown).

[0042] In some implementations, information collected by the pressure transducer 146 can be analyzed to determine various states of a person lying on the bed 112. For example, the processor 136 can use information collected by the pressure transducer 146 to determine a heart rate or a respiration rate for a person lying in the bed 112. For

example, a user can be lying on a side of the bed 112 that includes the chamber 114A. The pressure transducer 146 can monitor fluctuations in pressure of the chamber 114A and this information can be used to determine the user's heart rate and/or respiration rate. As another example, additional processing can be performed using the collected data to determine a sleep state of the person (e.g., awake, light sleep, deep sleep). For example, the processor 136 can determine when a person falls asleep and, while asleep, the various sleep states of the person.

[0043] Additional information associated with a user of the air bed system 100 that can be determined using information collected by the pressure transducer 146 includes motion of the user, presence of the user on a surface of the bed 112, weight of the user, heart arrhythmia of the user, and apnea. Taking user presence detection for example, the pressure transducer 146 can be used to detect the user's presence on the bed 112, e.g., via a gross pressure change determination and/or via one or more of a respiration rate signal, heart rate signal, and/or other biometric signals. For example, a simple pressure detection process can identify an increase in pressure as an indication that the user is present on the bed 112. As another example, the processor 136 can determine that the user is present on the bed 112 if the detected pressure increases above a specified threshold (so as to indicate that a person or other object above a certain weight is positioned on the bed 112). As yet another example, the processor 136 can identify an increase in pressure in combination with detected slight, rhythmic fluctuations in pressure as corresponding to the user being present on the bed 112. The presence of rhythmic fluctuations can be identified as being caused by respiration or heart rhythm (or both) of the user. The detection of respiration or a heartbeat can distinguish between the user being present on the bed and another object (e.g., a suit case) being placed upon the bed.

[0044] In some implementations, fluctuations in pressure can be measured at the pump 120. For example, one or more pressure sensors can be located within one or more internal cavities of the pump 120 to detect fluctuations in pressure within the pump 120. The fluctuations in pressure detected at the pump 120 can indicate fluctuations in pressure in one or both of the chambers 114A and 114B. One or more sensors located at the pump 120 can be in fluid communication with the one or both of the chambers 114A and 114B, and the sensors can be operative to determine pressure within the chambers

114A and 114B. The control box 124 can be configured to determine at least one vital sign (e.g., heart rate, respiratory rate) based on the pressure within the chamber 114A or the chamber 114B.

[0045] In some implementations, the control box 124 can analyze a pressure signal detected by one or more pressure sensors to determine a heart rate, respiration rate, and/or other vital signs of a user lying or sitting on the chamber 114A or the chamber 114B. More specifically, when a user lies on the bed 112 positioned over the chamber 114A, each of the user's heart beats, breaths, and other movements can create a force on the bed 112 that is transmitted to the chamber 114A. As a result of the force input to the chamber 114A from the user's movement, a wave can propagate through the chamber 114A and into the pump 120. A pressure sensor located at the pump 120 can detect the wave, and thus the pressure signal output by the sensor can indicate a heart rate, respiratory rate, or other information regarding the user.

[0046] With regard to sleep state, air bed system 100 can determine a user's sleep state by using various biometric signals such as heart rate, respiration, and/or movement of the user. While the user is sleeping, the processor 136 can receive one or more of the user's biometric signals (e.g., heart rate, respiration, and motion) and determine the user's present sleep state based on the received biometric signals. In some implementations, signals indicating fluctuations in pressure in one or both of the chambers 114A and 114B can be amplified and/or filtered to allow for more precise detection of heart rate and respiratory rate.

[0047] The control box 124 can perform a pattern recognition algorithm or other calculation based on the amplified and filtered pressure signal to determine the user's heart rate and respiratory rate. For example, the algorithm or calculation can be based on assumptions that a heart rate portion of the signal has a frequency in the range of 0.5-4.0 Hz and that a respiration rate portion of the signal has a frequency in the range of less than 1 Hz. The control box 124 can also be configured to determine other characteristics of a user based on the received pressure signal, such as blood pressure, tossing and turning movements, rolling movements, limb movements, weight, the presence or lack of presence of a user, and/or the identity of the user. Techniques for monitoring a user's sleep using heart rate information, respiration rate information, and other user

information are disclosed in U.S. Patent Application Publication No. 20100170043 to Steven J. Young et al., titled "APPARATUS FOR MONITORING VITAL SIGNS," the entire contents of which is incorporated herein by reference.

[0048] For example, the pressure transducer 146 can be used to monitor the air pressure in the chambers 114A and 114B of the bed 112. If the user on the bed 112 is not moving, the air pressure changes in the air chamber 114A or 114B can be relatively minimal, and can be attributable to respiration and/or heartbeat. When the user on the bed 112 is moving, however, the air pressure in the mattress can fluctuate by a much larger amount. Thus, the pressure signals generated by the pressure transducer 146 and received by the processor 136 can be filtered and indicated as corresponding to motion, heartbeat, or respiration.

[0049] In some implementations, rather than performing the data analysis in the control box 124 with the processor 136, a digital signal processor (DSP) can be provided to analyze the data collected by the pressure transducer 146. Alternatively, the data collected by the pressure transducer 146 could be sent to a cloud-based computing system for remote analysis.

[0050] In some implementations, the example air bed system 100 further includes a temperature controller configured to increase, decrease, or maintain the temperature of a bed, for example for the comfort of the user. For example, a pad can be placed on top of or be part of the bed 112, or can be placed on top of or be part of one or both of the chambers 114A and 114B. Air can be pushed through the pad and vented to cool off a user of the bed. Conversely, the pad can include a heating element that can be used to keep the user warm. In some implementations, the temperature controller can receive temperature readings from the pad. In some implementations, separate pads are used for the different sides of the bed 112 (e.g., corresponding to the locations of the chambers 114A and 114B) to provide for differing temperature control for the different sides of the bed.

[0051] In some implementations, the user of the air bed system 100 can use an input device, such as the remote control 122, to input a desired temperature for the surface of the bed 112 (or for a portion of the surface of the bed 112). The desired temperature can be encapsulated in a command data structure that includes the desired

temperature as well as identifies the temperature controller as the desired component to be controlled. The command data structure can then be transmitted via Bluetooth or another suitable communication protocol to the processor 136. In various examples, the command data structure is encrypted before being transmitted. The temperature controller can then configure its elements to increase or decrease the temperature of the pad depending on the temperature input into remote control 122 by the user.

[0052] In some implementations, data can be transmitted from a component back to the processor 136 or to one or more display devices, such as the display 126. For example, the current temperature as determined by a sensor element of temperature controller, the pressure of the bed, the current position of the foundation or other information can be transmitted to control box 124. The control box 124 can then transmit the received information to remote control 122 where it can be displayed to the user (e.g., on the display 126).

[0053] In some implementations, the example air bed system 100 further includes an adjustable foundation and an articulation controller configured to adjust the position of a bed (e.g., the bed 112) by adjusting the adjustable foundation that supports the bed. For example, the articulation controller can adjust the bed 112 from a flat position to a position in which a head portion of a mattress of the bed is inclined upward (e.g., to facilitate a user sitting up in bed and/or watching television). In some implementations, the bed 112 includes multiple separately articulable sections. For example, portions of the bed corresponding to the locations of the chambers 114A and 114B can be articulated independently from each other, to allow one person positioned on the bed 112 surface to rest in a first position (e.g., a flat position) while a second person rests in a second position (e.g., an reclining position with the head raised at an angle from the waist). In some implementations, separate positions can be set for two different beds (e.g., two twin beds placed next to each other). The foundation of the bed 112 can include more than one zone that can be independently adjusted. The articulation controller can also be configured to provide different levels of massage to one or more users on the bed 112.

[0054] Example of a Bed in a Bedroom Environment

[0055] FIG. 3 shows an example environment 300 including a bed 302 in communication with devices located in and around a home. In the example shown, the

bed 302 includes pump 304 for controlling air pressure within two air chambers 306a and 306b (as described above with respect to the air chambers 114A-114B). The pump 304 additionally includes circuitry for controlling inflation and deflation functionality performed by the pump 304. The circuitry is further programmed to detect fluctuations in air pressure of the air chambers 306a-b and used the detected fluctuations in air pressure to identify bed presence of a user 308, sleep state of the user 308, movement of the user 308, and biometric signals of the user 308 such as heart rate and respiration rate. In the example shown, the pump 304 is located within a support structure of the bed 302 and the control circuitry 334 for controlling the pump 304 is integrated with the pump 304. In some implementations, the control circuitry 334 is physically separate from the pump 304 and is in wireless or wired communication with the pump 304. In some implementations, the pump 304 and/or control circuitry 334 are located outside of the bed 302. In some implementations, various control functions can be performed by systems located in different physical locations. For example, circuitry for controlling actions of the pump 304 can be located within a pump casing of the pump 304 while control circuitry 334 for performing other functions associated with the bed 302 can be located in another portion of the bed 302, or external to the bed 302. As another example, control circuitry 334 located within the pump 304 can communicate with control circuitry 334 at a remote location through a LAN or WAN (e.g., the internet). As yet another example, the control circuitry 334 can be included in the control box 124 of FIGs. 1 and 2.

[0056] In some implementations, one or more devices other than, or in addition to, the pump 304 and control circuitry 334 can be utilized to identify user bed presence, sleep state, movement, and biometric signals. For example, the bed 302 can include a second pump in addition to the pump 304, with each of the two pumps connected to a respective one of the air chambers 306a-b. For example, the pump 304 can be in fluid communication with the air chamber 306b to control inflation and deflation of the air chamber 306b as well as detect user signals for a user located over the air chamber 306b such as bed presence, sleep state, movement, and biometric signals while the second pump is in fluid communication with the air chamber 306a to control inflation and deflation of the air chamber 306a as well as detect user signals for a user located over the air chamber 306a.

[0057] As another example, the bed 302 can include one or more pressure sensitive pads or surface portions that are operable to detect movement, including user presence, user motion, respiration, and heart rate. For example, a first pressure sensitive pad can be incorporated into a surface of the bed 302 over a left portion of the bed 302, where a first user would normally be located during sleep, and a second pressure sensitive pad can be incorporated into the surface of the bed 302 over a right portion of the bed 302, where a second user would normally be located during sleep. The movement detected by the one or more pressure sensitive pads or surface portions can be used by control circuitry 334 to identify user sleep state, bed presence, or biometric signals.

[0058] In some implementations, information detected by the bed (e.g., motion information) is processed by control circuitry 334 (e.g., control circuitry 334 integrated with the pump 304) and provided to one or more user devices such as a user device 310 for presentation to the user 308 or to other users. In the example depicted in FIG. 3, the user device 310 is a tablet device; however, in some implementations, the user device 310 can be a personal computer, a smart phone, a smart television (e.g., a television 312), or other user device capable of wired or wireless communication with the control circuitry 334. The user device 310 can be in communication with control circuitry 334 of the bed 302 through a network or through direct point-to-point communication. For example, the control circuitry 334 can be connected to a LAN (e.g., through a Wi-Fi router) and communicate with the user device 310 through the LAN. As another example, the control circuitry 334 and the user device 310 can both connect to the Internet and communicate through the Internet. For example, the control circuitry 334 can connect to the Internet through a WiFi router and the user device 310 can connect to the Internet through communication with a cellular communication system. As another example, the control circuitry 334 can communicate directly with the user device 310 through a wireless communication protocol such as Bluetooth. As yet another example, the control circuitry 334 can communicate with the user device 310 through a wireless communication protocol such as ZigBee, Z-Wave, infrared, or another wireless communication protocol suitable for the application. As another example, the control circuitry 334 can communicate with the user device 310 through a wired connection such

as, for example, a USB connector, serial/RS232, or another wired connection suitable for the application.

[0059] The user device 310 can display a variety of information and statistics related to sleep, or user 308's interaction with the bed 302. For example, a user interface displayed by the user device 310 can present information including amount of sleep for the user 308 over a period of time (e.g., a single evening, a week, a month, etc.) amount of deep sleep, ratio of deep sleep to restless sleep, time lapse between the user 308 getting into bed and the user 308 falling asleep, total amount of time spent in the bed 302 for a given period of time, heart rate for the user 308 over a period of time, respiration rate for the user 308 over a period of time, or other information related to user interaction with the bed 302 by the user 308 or one or more other users of the bed 302. In some implementations, information for multiple users can be presented on the user device 310, for example information for a first user positioned over the air chamber 306a can be presented along with information for a second user positioned over the air chamber 306b. In some implementations, the information presented on the user device 310 can vary according to the age of the user 308. For example, the information presented on the user device 310 can evolve with the age of the user 308 such that different information is presented on the user device 310 as the user 308 ages as a child or an adult.

[0060] The user device 310 can also be used as an interface for the control circuitry 334 of the bed 302 to allow the user 308 to enter information. The information entered by the user 308 can be used by the control circuitry 334 to provide better information to the user or to various control signals for controlling functions of the bed 302 or other devices. For example, the user can enter information such as weight, height, and age and the control circuitry 334 can use this information to provide the user 308 with a comparison of the user's tracked sleep information to sleep information of other people having similar weights, heights, and/or ages as the user 308. As another example, the user 308 can use the user device 310 as an interface for controlling air pressure of the air chambers 306a and 306b, for controlling various recline or incline positions of the bed 302, for controlling temperature of one or more surface temperature control devices of the bed 302, or for allowing the control circuitry 334 to generate control signals for other devices (as described in greater detail below).

[0061] In some implementations, control circuitry 334 of the bed 302 (e.g., control circuitry 334 integrated into the pump 304) can communicate with other first, second, or third party devices or systems in addition to or instead of the user device 310. For example, the control circuitry 334 can communicate with the television 312, a lighting system 314, a thermostat 316, a security system 318, or other house hold devices such as an oven 322, a coffee maker 324, a lamp 326, and a nightlight 328. Other examples of devices and/or systems that the control circuitry 334 can communicate with include a system for controlling window blinds 330, one or more devices for detecting or controlling the states of one or more doors 332 (such as detecting if a door is open, detecting if a door is locked, or automatically locking a door), and a system for controlling a garage door 320 (e.g., control circuitry 334 integrated with a garage door opener for identifying an open or closed state of the garage door 320 and for causing the garage door opener to open or close the garage door 320). Communications between the control circuitry 334 of the bed 302 and other devices can occur through a network (e.g., a LAN or the Internet) or as point-to-point communication (e.g., using Bluetooth, radio communication, or a wired connection). In some implementations, control circuitry 334 of different beds 302 can communicate with different sets of devices. For example, a kid bed may not communicate with and/or control the same devices as an adult bed. In some embodiments, the bed 302 can evolve with the age of the user such that the control circuitry 334 of the bed 302 communicates with different devices as a function of age of the user.

[0062] The control circuitry 334 can receive information and inputs from other devices/systems and use the received information and inputs to control actions of the bed 302 or other devices. For example, the control circuitry 334 can receive information from the thermostat 316 indicating a current environmental temperature for a house or room in which the bed 302 is located. The control circuitry 334 can use the received information (along with other information) to determine if a temperature of all or a portion of the surface of the bed 302 should be raised or lowered. The control circuitry 334 can then cause a heating or cooling mechanism of the bed 302 to raise or lower the temperature of the surface of the bed 302. For example, the user 308 can indicate a desired sleeping temperature of 74 degrees while a second user of the bed 302 indicates a

desired sleeping temperature of 72 degrees. The thermostat 316 can indicate to the control circuitry 334 that the current temperature of the bedroom is 72 degrees. The control circuitry 334 can identify that the user 308 has indicated a desired sleeping temperature of 74 degrees, and send control signals to a heating pad located on the user 308's side of the bed to raise the temperature of the portion of the surface of the bed 302 where the user 308 is located to raise the temperature of the user 308's sleeping surface to the desired temperature.

[0063] The control circuitry 334 can also generate control signals controlling other devices and propagate the control signals to the other devices. In some implementations, the control signals are generated based on information collected by the control circuitry 334, including information related to user interaction with the bed 302 by the user 308 and/or one or more other users. In some implementations, information collected from one or more other devices other than the bed 302 are used when generating the control signals. For example, information relating to environmental occurrences (e.g., environmental temperature, environmental noise level, and environmental light level), time of day, time of year, day of the week, or other information can be used when generating control signals for various devices in communication with the control circuitry 334 of the bed 302. For example, information on the time of day can be combined with information relating to movement and bed presence of the user 308 to generate control signals for the lighting system 314. In some implementations, rather than or in addition to providing control signals for one or more other devices, the control circuitry 334 can provide collected information (e.g., information related to user movement, bed presence, sleep state, or biometric signals for the user 308) to one or more other devices to allow the one or more other devices to utilize the collected information when generating control signals. For example, control circuitry 334 of the bed 302 can provide information relating to user interactions with the bed 302 by the user 308 to a central controller (not shown) that can use the provided information to generate control signals for various devices, including the bed 302.

[0064] Still referring to FIG. 3, the control circuitry 334 of the bed 302 can generate control signals for controlling actions of other devices, and transmit the control signals to the other devices in response to information collected by the control circuitry

334, including bed presence of the user 308, sleep state of the user 308, and other factors. For example, control circuitry 334 integrated with the pump 304 can detect a feature of a mattress of the bed 302, such as an increase in pressure in the air chamber 306b, and use this detected increase in air pressure to determine that the user 308 is present on the bed 302. In some implementations, the control circuitry 334 can identify a heart rate or respiratory rate for the user 308 to identify that the increase in pressure is due to a person sitting, laying, or otherwise resting on the bed 302 rather than an inanimate object (such as a suitcase) having been placed on the bed 302. In some implementations, the information indicating user bed presence is combined with other information to identify a current or future likely state for the user 308. For example, a detected user bed presence at 11:00am can indicate that the user is sitting on the bed (e.g., to tie her shoes, or to read a book) and does not intend to go to sleep, while a detected user bed presence at 10:00pm can indicate that the user 308 is in bed for the evening and is intending to fall asleep soon. As another example, if the control circuitry 334 detects that the user 308 has left the bed 302 at 6:30am (e.g., indicating that the user 308 has woken up for the day), and then later detects user bed presence of the user 308 at 7:30am, the control circuitry 334 can use this information that the newly detected user bed presence is likely temporary (e.g., while the user 308 ties her shoes before heading to work) rather than an indication that the user 308 is intending to stay on the bed 302 for an extended period.

[0065] In some implementations, the control circuitry 334 is able to use collected information (including information related to user interaction with the bed 302 by the user 308, as well as environmental information, time information, and input received from the user) to identify use patterns for the user 308. For example, the control circuitry 334 can use information indicating bed presence and sleep states for the user 308 collected over a period of time to identify a sleep pattern for the user. For example, the control circuitry 334 can identify that the user 308 generally goes to bed between 9:30pm and 10:00pm, generally falls asleep between 10:00pm and 11:00pm, and generally wakes up between 6:30am and 6:45am based on information indicating user presence and biometrics for the user 308 collected over a week. The control circuitry 334 can use identified patterns for a user to better process and identify user interactions with the bed 302 by the user 308.

[0066] For example, given the above example user bed presence, sleep, and wake patterns for the user 308, if the user 308 is detected as being on the bed at 3:00pm, the control circuitry 334 can determine that the user's presence on the bed is only temporary, and use this determination to generate different control signals than would be generated if the control circuitry 334 determined that the user 308 was in bed for the evening. As another example, if the control circuitry 334 detects that the user 308 has gotten out of bed at 3:00am, the control circuitry 334 can use identified patterns for the user 308 to determine that the user has only gotten up temporarily (for example, to use the rest room, or get a glass of water) and is not up for the day. By contrast, if the control circuitry 334 identifies that the user 308 has gotten out of the bed 302 at 6:40am, the control circuitry 334 can determine that the user is up for the day and generate a different set of control signals than those that would be generated if it were determined that the user 308 were only getting out of bed temporarily (as would be the case when the user 308 gets out of the bed 302 at 3:00am). For other users 308, getting out of the bed 302 at 3:00am can be the normal wake-up time, which the control circuitry 334 can learn and respond to accordingly.

[0067] As described above, the control circuitry 334 for the bed 302 can generate control signals for control functions of various other devices. The control signals can be generated, at least in part, based on detected interactions by the user 308 with the bed 302, as well as other information including time, date, temperature, etc. For example, the control circuitry 334 can communicate with the television 312, receive information from the television 312, and generate control signals for controlling functions of the television 312. For example, the control circuitry 334 can receive an indication from the television 312 that the television 312 is currently on. If the television 312 is located in a different room from the bed 302, the control circuitry 334 can generate a control signal to turn the television 312 off upon making a determination that the user 308 has gone to bed for the evening. For example, if bed presence of the user 308 on the bed 302 is detected during a particular time range (e.g., between 8:00pm and 7:00am) and persists for longer than a threshold period of time (e.g., 10 minutes) the control circuitry 334 can use this information to determine that the user 308 is in bed for the evening. If the television 312 is on (as indicated by communications received by the control circuitry 334 of the bed

302 from the television 312) the control circuitry 334 can generate a control signal to turn the television 312 off. The control signals can then be transmitted to the television (e.g., through a directed communication link between the television 312 and the control circuitry 334 or through a network). As another example, rather than turning off the television 312 in response to detection of user bed presence, the control circuitry 334 can generate a control signal that causes the volume of the television 312 to be lowered by a pre-specified amount.

[0068] As another example, upon detecting that the user 308 has left the bed 302 during a specified time range (e.g., between 6:00am and 8:00am) the control circuitry 334 can generate control signals to cause the television 312 to turn on and tune to a pre-specified channel (e.g., the user 308 has indicated a preference for watching the morning news upon getting out of bed in the morning). The control circuitry 334 can generate the control signal and transmit the signal to the television 312 to cause the television 312 to turn on and tune to the desired station (which could be stored at the control circuitry 334, the television 312, or another location). As another example, upon detecting that the user 308 has gotten up for the day, the control circuitry 334 can generate and transmit control signals to cause the television 312 to turn on and begin playing a previously recorded program from a digital video recorder (DVR) in communication with the television 312.

[0069] As another example, if the television 312 is in the same room as the bed 302, the control circuitry 334 does not cause the television 312 to turn off in response to detection of user bed presence. Rather, the control circuitry 334 can generate and transmit control signals to cause the television 312 to turn off in response to determining that the user 308 is asleep. For example, the control circuitry 334 can monitor biometric signals of the user 308 (e.g., motion, heart rate, respiration rate) to determine that the user 308 has fallen asleep. Upon detecting that the user 308 is sleeping, the control circuitry 334 generates and transmits a control signal to turn the television 312 off. As another example, the control circuitry 334 can generate the control signal to turn off the television 312 after a threshold period of time after the user 308 has fallen asleep (e.g., 10 minutes after the user has fallen asleep). As another example, the control circuitry 334 generates control signals to lower the volume of the television 312 after determining that the user 308 is asleep. As yet another example, the control circuitry 334 generates and transmits a

control signal to cause the television to gradually lower in volume over a period of time and then turn off in response to determining that the user 308 is asleep.

[0070] In some implementations, the control circuitry 334 can similarly interact with other media devices, such as computers, tablets, smart phones, stereo systems, etc. For example, upon detecting that the user 308 is asleep, the control circuitry 334 can generate and transmit a control signal to the user device 310 to cause the user device 310 to turn off, or turn down the volume on a video or audio file being played by the user device 310.

[0071] The control circuitry 334 can additionally communicate with the lighting system 314, receive information from the lighting system 314, and generate control signals for controlling functions of the lighting system 314. For example, upon detecting user bed presence on the bed 302 during a certain time frame (e.g., between 8:00pm and 7:00am) that lasts for longer than a threshold period of time (e.g., 10 minutes) the control circuitry 334 of the bed 302 can determine that the user 308 is in bed for the evening. In response to this determination, the control circuitry 334 can generate control signals to cause lights in one or more rooms other than the room in which the bed 302 is located to switch off. The control signals can then be transmitted to the lighting system 314 and executed by the lighting system 314 to cause the lights in the indicated rooms to shut off. For example, the control circuitry 334 can generate and transmit control signals to turn off lights in all common rooms, but not in other bedrooms. As another example, the control signals generated by the control circuitry 334 can indicate that lights in all rooms other than the room in which the bed 302 is located are to be turned off, while one or more lights located outside of the house containing the bed 302 are to be turned on, in response to determining that the user 308 is in bed for the evening. Additionally, the control circuitry 334 can generate and transmit control signals to cause the nightlight 328 to turn on in response to determining user 308 bed presence or whether the user 308 is asleep. As another example, the control circuitry 334 can generate first control signals for turning off a first set of lights (e.g., lights in common rooms) in response to detecting user bed presence, and second control signals for turning off a second set of lights (e.g., lights in the room in which the bed 302 is located) in response to detecting that the user 308 is asleep.

[0072] In some implementations, in response to determining that the user 308 is in bed for the evening, the control circuitry 334 of the bed 302 can generate control signals to cause the lighting system 314 to implement a sunset lighting scheme in the room in which the bed 302 is located. A sunset lighting scheme can include, for example, dimming the lights (either gradually over time, or all at once) in combination with changing the color of the light in the bedroom environment, such as adding an amber hue to the lighting in the bedroom. The sunset lighting scheme can help to put the user 308 to sleep when the control circuitry 334 has determined that the user 308 is in bed for the evening.

[0073] The control circuitry 334 can also be configured to implement a sunrise lighting scheme when the user 308 wakes up in the morning. The control circuitry 334 can determine that the user 308 is awake for the day, for example, by detecting that the user 308 has gotten off of the bed 302 (i.e., is no longer present on the bed 302) during a specified time frame (e.g., between 6:00am and 8:00am). As another example, the control circuitry 334 can monitor movement, heart rate, respiratory rate, or other biometric signals of the user 308 to determine that the user 308 is awake even though the user 308 has not gotten out of bed. If the control circuitry 334 detects that the user is awake during a specified time frame, the control circuitry 334 can determine that the user 308 is awake for the day. The specified time frame can be, for example, based on previously recorded user bed presence information collected over a period of time (e.g., two weeks) that indicates that the user 308 usually wakes up for the day between 6:30am and 7:30am. In response to the control circuitry 334 determining that the user 308 is awake, the control circuitry 334 can generate control signals to cause the lighting system 314 to implement the sunrise lighting scheme in the bedroom in which the bed 302 is located. The sunrise lighting scheme can include, for example, turning on lights (e.g., the lamp 326, or other lights in the bedroom). The sunrise lighting scheme can further include gradually increasing the level of light in the room where the bed 302 is located (or in one or more other rooms). The sunrise lighting scheme can also include only turning on lights of specified colors. For example, the sunrise lighting scheme can include lighting the bedroom with blue light to gently assist the user 308 in waking up and becoming active.

[0074] In some implementations, the control circuitry 334 can generate different control signals for controlling actions of one or more components, such as the lighting system 314, depending on a time of day that user interactions with the bed 302 are detected. For example, the control circuitry 334 can use historical user interaction information for interactions between the user 308 and the bed 302 to determine that the user 308 usually falls asleep between 10:00pm and 11:00pm and usually wakes up between 6:30am and 7:30am on weekdays. The control circuitry 334 can use this information to generate a first set of control signals for controlling the lighting system 314 if the user 308 is detected as getting out of bed at 3:00am and to generate a second set of control signals for controlling the lighting system 314 if the user 308 is detected as getting out of bed after 6:30am. For example, if the user 308 gets out of bed prior to 6:30am, the control circuitry 334 can turn on lights that guide the user 308's route to a restroom. As another example, if the user 308 gets out of bed prior to 6:30am, the control circuitry 334 can turn on lights that guide the user 308's route to the kitchen (which can include, for example, turning on the nightlight 328, turning on under bed lighting, or turning on the lamp 326).

[0075] As another example, if the user 308 gets out of bed after 6:30am, the control circuitry 334 can generate control signals to cause the lighting system 314 to initiate a sunrise lighting scheme, or to turn on one or more lights in the bedroom and/or other rooms. In some implementations, if the user 308 is detected as getting out of bed prior to a specified morning rise time for the user 308, the control circuitry 334 causes the lighting system 314 to turn on lights that are dimmer than lights that are turned on by the lighting system 314 if the user 308 is detected as getting out of bed after the specified morning rise time. Causing the lighting system 314 to only turn on dim lights when the user 308 gets out of bed during the night (i.e., prior to normal rise time for the user 308) can prevent other occupants of the house from being woken by the lights while still allowing the user 308 to see in order to reach the restroom, kitchen, or another destination within the house.

[0076] The historical user interaction information for interactions between the user 308 and the bed 302 can be used to identify user sleep and awake time frames. For example, user bed presence times and sleep times can be determined for a set period of

time (e.g., two weeks, a month, etc.). The control circuitry 334 can then identify a typical time range or time frame in which the user 308 goes to bed, a typical time frame for when the user 308 falls asleep, and a typical time frame for when the user 308 wakes up (and in some cases, different time frames for when the user 308 wakes up and when the user 308 actually gets out of bed). In some implementations, buffer time can be added to these time frames. For example, if the user is identified as typically going to bed between 10:00pm and 10:30pm, a buffer of a half hour in each direction can be added to the time frame such that any detection of the user getting onto the bed between 9:30pm and 11:00pm is interpreted as the user 308 going to bed for the evening. As another example, detection of bed presence of the user 308 starting from a half hour before the earliest typical time that the user 308 goes to bed extending until the typical wake up time (e.g., 6:30 am) for the user can be interpreted as the user going to bed for the evening. For example, if the user typically goes to bed between 10:00pm and 10:30pm, if the user's bed presence is sensed at 12:30am one night, that can be interpreted as the user getting into bed for the evening even though this is outside of the user's typical time frame for going to bed because it has occurred prior to the user's normal wake up time. In some implementations, different time frames are identified for different times of the year (e.g., earlier bed time during winter vs. summer) or at different times of the week (e.g., user wakes up earlier on weekdays than on weekends).

[0077] The control circuitry 334 can distinguish between the user 308 going to bed for an extended period (such as for the night) as opposed to being present on the bed 302 for a shorter period (such as for a nap) by sensing duration of presence of the user 308. In some examples, the control circuitry 334 can distinguish between the user 308 going to bed for an extended period (such as for the night) as opposed to going to bed for a shorter period (such as for a nap) by sensing duration of sleep of the user 308. For example, the control circuitry 334 can set a time threshold whereby if the user 308 is sensed on the bed 302 for longer than the threshold, the user 308 is considered to have gone to bed for the night. In some examples, the threshold can be about 2 hours, whereby if the user 308 is sensed on the bed 302 for greater than 2 hours, the control circuitry 334 registers that as an extended sleep event. In other examples, the threshold can be greater than or less than two hours.

[0078] The control circuitry 334 can detect repeated extended sleep events to determine a typical bed time range of the user 308 automatically, without requiring the user 308 to enter a bed time range. This can allow the control circuitry 334 to accurately estimate when the user 308 is likely to go to bed for an extended sleep event, regardless of whether the user 308 typically goes to bed using a traditional sleep schedule or a non-traditional sleep schedule. The control circuitry 334 can then use knowledge of the bed time range of the user 308 to control one or more components (including components of the bed 302 and/or non-bed peripherals) differently based on sensing bed presence during the bed time range or outside of the bed time range.

[0079] In some examples, the control circuitry 334 can automatically determine the bed time range of the user 308 without requiring user inputs. In some examples, the control circuitry 334 can determine the bed time range of the user 308 automatically and in combination with user inputs. In some examples, the control circuitry 334 can set the bed time range directly according to user inputs. In some examples, the control circuitry 334 can associate different bed times with different days of the week. In each of these examples, the control circuitry 334 can control one or more components (such as the lighting system 314, the thermostat 316, the security system 318, the oven 322, the coffee maker 324, the lamp 326, and the nightlight 328), as a function of sensed bed presence and the bed time range.

[0080] The control circuitry 334 can additionally communicate with the thermostat 316, receive information from the thermostat 316, and generate control signals for controlling functions of the thermostat 316. For example, the user 308 can indicate user preferences for different temperatures at different times, depending on the sleep state or bed presence of the user 308. For example, the user 308 may prefer an environmental temperature of 72 degrees when out of bed, 70 degrees when in bed but awake, and 68 degrees when sleeping. The control circuitry 334 of the bed 302 can detect bed presence of the user 308 in the evening and determine that the user 308 is in bed for the night. In response to this determination, the control circuitry 334 can generate control signals to cause the thermostat to change the temperature to 70 degrees. The control circuitry 334 can then transmit the control signals to the thermostat 316. Upon detecting that the user 308 is in bed during the bed time range or asleep, the control circuitry 334 can generate

and transmit control signals to cause the thermostat 316 to change the temperature to 68. The next morning, upon determining that the user is awake for the day (e.g., the user 308 gets out of bed after 6:30am) the control circuitry 334 can generate and transmit control circuitry 334 to cause the thermostat to change the temperature to 72 degrees.

[0081] In some implementations, the control circuitry 334 can similarly generate control signals to cause one or more heating or cooling elements on the surface of the bed 302 to change temperature at various times, either in response to user interaction with the bed 302 or at various pre-programmed times. For example, the control circuitry 334 can activate a heating element to raise the temperature of one side of the surface of the bed 302 to 73 degrees when it is detected that the user 308 has fallen asleep. As another example, upon determining that the user 308 is up for the day, the control circuitry 334 can turn off a heating or cooling element. As yet another example, the user 308 can pre-program various times at which the temperature at the surface of the bed should be raised or lowered. For example, the user can program the bed 302 to raise the surface temperature to 76 degrees at 10:00pm, and lower the surface temperature to 68 degrees at 11:30pm.

[0082] In some implementations, in response to detecting user bed presence of the user 308 and/or that the user 308 is asleep, the control circuitry 334 can cause the thermostat 316 to change the temperature in different rooms to different values. For example, in response to determining that the user 308 is in bed for the evening, the control circuitry 334 can generate and transmit control signals to cause the thermostat 316 to set the temperature in one or more bedrooms of the house to 72 degrees and set the temperature in other rooms to 67 degrees.

[0083] The control circuitry 334 can also receive temperature information from the thermostat 316 and use this temperature information to control functions of the bed 302 or other devices. For example, as discussed above, the control circuitry 334 can adjust temperatures of heating elements included in the bed 302 in response to temperature information received from the thermostat 316.

[0084] In some implementations, the control circuitry 334 can generate and transmit control signals for controlling other temperature control systems. For example, in response to determining that the user 308 is awake for the day, the control circuitry 334

can generate and transmit control signals for causing floor heating elements to activate. For example, the control circuitry 334 can cause a floor heating system for a master bedroom to turn on in response to determining that the user 308 is awake for the day.

[0085] The control circuitry 334 can additionally communicate with the security system 318, receive information from the security system 318, and generate control signals for controlling functions of the security system 318. For example, in response to detecting that the user 308 is in bed for the evening, the control circuitry 334 can generate control signals to cause the security system to engage or disengage security functions. The control circuitry 334 can then transmit the control signals to the security system 318 to cause the security system 318 to engage. As another example, the control circuitry 334 can generate and transmit control signals to cause the security system 318 to disable in response to determining that the user 308 is awake for the day (e.g., user 308 is no longer present on the bed 302 after 6:00am). In some implementations, the control circuitry 334 can generate and transmit a first set of control signals to cause the security system 318 to engage a first set of security features in response to detecting user bed presence of the user 308, and can generate and transmit a second set of control signals to cause the security system 318 to engage a second set of security features in response to detecting that the user 308 has fallen asleep.

[0086] In some implementations, the control circuitry 334 can receive alerts from the security system 318 (and/or a cloud service associated with the security system 318) and indicate the alert to the user 308. For example, the control circuitry 334 can detect that the user 308 is in bed for the evening and in response, generate and transmit control signals to cause the security system 318 to engage or disengage. The security system can then detect a security breach (e.g., someone has opened the door 332 without entering the security code, or someone has opened a window when the security system 318 is engaged). The security system 318 can communicate the security breach to the control circuitry 334 of the bed 302. In response to receiving the communication from the security system 318, the control circuitry 334 can generate control signals to alert the user 308 to the security breach. For example, the control circuitry 334 can cause the bed 302 to vibrate. As another example, the control circuitry 334 can cause portions of the bed 302 to articulate (e.g., cause the head section to raise or lower) in order to wake the user

308 and alert the user to the security breach. As another example, the control circuitry 334 can generate and transmit control signals to cause the lamp 326 to flash on and off at regular intervals to alert the user 308 to the security breach. As another example, the control circuitry 334 can alert the user 308 of one bed 302 regarding a security breach in a bedroom of another bed, such as an open window in a kid's bedroom. As another example, the control circuitry 334 can send an alert to a garage door controller (e.g., to close and lock the door). As another example, the control circuitry 334 can send an alert for the security to be disengaged.

[0087] The control circuitry 334 can additionally generate and transmit control signals for controlling the garage door 320 and receive information indicating a state of the garage door 320 (i.e., open or closed). For example, in response to determining that the user 308 is in bed for the evening, the control circuitry 334 can generate and transmit a request to a garage door opener or another device capable of sensing if the garage door 320 is open. The control circuitry 334 can request information on the current state of the garage door 320. If the control circuitry 334 receives a response (e.g., from the garage door opener) indicating that the garage door 320 is open, the control circuitry 334 can either notify the user 308 that the garage door is open, or generate a control signal to cause the garage door opener to close the garage door 320. For example, the control circuitry 334 can send a message to the user device 310 indicating that the garage door is open. As another example, the control circuitry 334 can cause the bed 302 to vibrate. As yet another example, the control circuitry 334 can generate and transmit a control signal to cause the lighting system 314 to cause one or more lights in the bedroom to flash to alert the user 308 to check the user device 310 for an alert (in this example, an alert regarding the garage door 320 being open). Alternatively, or additionally, the control circuitry 334 can generate and transmit control signals to cause the garage door opener to close the garage door 320 in response to identifying that the user 308 is in bed for the evening and that the garage door 320 is open. In some implementations, control signals can vary depend on the age of the user 308.

[0088] The control circuitry 334 can similarly send and receive communications for controlling or receiving state information associated with the door 332 or the oven 322. For example, upon detecting that the user 308 is in bed for the evening, the control

circuitry 334 can generate and transmit a request to a device or system for detecting a state of the door 332. Information returned in response to the request can indicate various states for the door 332 such as open, closed but unlocked, or closed and locked. If the door 332 is open or closed but unlocked, the control circuitry 334 can alert the user 308 to the state of the door, such as in a manner described above with reference to the garage door 320. Alternatively, or in addition to alerting the user 308, the control circuitry 334 can generate and transmit control signals to cause the door 332 to lock, or to close and lock. If the door 332 is closed and locked, the control circuitry 334 can determine that no further action is needed.

[0089] Similarly, upon detecting that the user 308 is in bed for the evening, the control circuitry 334 can generate and transmit a request to the oven 322 to request a state of the oven 322 (e.g., on or off). If the oven 322 is on, the control circuitry 334 can alert the user 308 and/or generate and transmit control signals to cause the oven 322 to turn off. If the oven is already off, the control circuitry 334 can determine that no further action is necessary. In some implementations, different alerts can be generated for different events. For example, the control circuitry 334 can cause the lamp 326 (or one or more other lights, via the lighting system 314) to flash in a first pattern if the security system 318 has detected a breach, flash in a second pattern if garage door 320 is on, flash in a third pattern if the door 332 is open, flash in a fourth pattern if the oven 322 is on, and flash in a fifth pattern if another bed has detected that a user of that bed has gotten up (e.g., that a child of the user 308 has gotten out of bed in the middle of the night as sensed by a sensor in the bed 302 of the child). Other examples of alerts that can be processed by the control circuitry 334 of the bed 302 and communicated to the user include a smoke detector detecting smoke (and communicating this detection of smoke to the control circuitry 334), a carbon monoxide tester detecting carbon monoxide, a heater malfunctioning, or an alert from any other device capable of communicating with the control circuitry 334 and detecting an occurrence that should be brought to the user 308's attention.

[0090] The control circuitry 334 can also communicate with a system or device for controlling a state of the window blinds 330. For example, in response to determining that the user 308 is in bed for the evening, the control circuitry 334 can generate and

transmit control signals to cause the window blinds 330 to close. As another example, in response to determining that the user 308 is up for the day (e.g., user has gotten out of bed after 6:30am) the control circuitry 334 can generate and transmit control signals to cause the window blinds 330 to open. By contrast, if the user 308 gets out of bed prior to a normal rise time for the user 308, the control circuitry 334 can determine that the user 308 is not awake for the day and does not generate control signals for causing the window blinds 330 to open. As yet another example, the control circuitry 334 can generate and transmit control signals that cause a first set of blinds to close in response to detecting user bed presence of the user 308 and a second set of blinds to close in response to detecting that the user 308 is asleep.

[0091] The control circuitry 334 can generate and transmit control signals for controlling functions of other household devices in response to detecting user interactions with the bed 302. For example, in response to determining that the user 308 is awake for the day, the control circuitry 334 can generate and transmit control signals to the coffee maker 324 to cause the coffee maker 324 to begin brewing coffee. As another example, the control circuitry 334 can generate and transmit control signals to the oven 322 to cause the oven to begin preheating (for users that like fresh baked bread in the morning). As another example, the control circuitry 334 can use information indicating that the user 308 is awake for the day along with information indicating that the time of year is currently winter and/or that the outside temperature is below a threshold value to generate and transmit control signals to cause a car engine block heater to turn on.

[0092] As another example, the control circuitry 334 can generate and transmit control signals to cause one or more devices to enter a sleep mode in response to detecting user bed presence of the user 308, or in response to detecting that the user 308 is asleep. For example, the control circuitry 334 can generate control signals to cause a mobile phone of the user 308 to switch into sleep mode. The control circuitry 334 can then transmit the control signals to the mobile phone. Later, upon determining that the user 308 is up for the day, the control circuitry 334 can generate and transmit control signals to cause the mobile phone to switch out of sleep mode.

[0093] In some implementations, the control circuitry 334 can communicate with one or more noise control devices. For example, upon determining that the user 308 is in

bed for the evening, or that the user 308 is asleep, the control circuitry 334 can generate and transmit control signals to cause one or more noise cancelation devices to activate. The noise cancelation devices can, for example, be included as part of the bed 302 or located in the bedroom with the bed 302. As another example, upon determining that the user 308 is in bed for the evening or that the user 308 is asleep, the control circuitry 334 can generate and transmit control signals to turn the volume on, off, up, or down, for one or more sound generating devices, such as a stereo system radio, computer, tablet, etc.

[0094] Additionally, functions of the bed 302 are controlled by the control circuitry 334 in response to user interactions with the bed 302. For example, the bed 302 can include an adjustable foundation and an articulation controller configured to adjust the position of one or more portions of the bed 302 by adjusting the adjustable foundation that supports the bed. For example, the articulation controller can adjust the bed 302 from a flat position to a position in which a head portion of a mattress of the bed 302 is inclined upward (e.g., to facilitate a user sitting up in bed and/or watching television). In some implementations, the bed 302 includes multiple separately articulable sections. For example, portions of the bed corresponding to the locations of the air chambers 306a and 306b can be articulated independently from each other, to allow one person positioned on the bed 302 surface to rest in a first position (e.g., a flat position) while a second person rests in a second position (e.g., a reclining position with the head raised at an angle from the waist). In some implementations, separate positions can be set for two different beds (e.g., two twin beds placed next to each other). The foundation of the bed 302 can include more than one zone that can be independently adjusted. The articulation controller can also be configured to provide different levels of massage to one or more users on the bed 302 or to cause the bed to vibrate to communicate alerts to the user 308 as described above.

[0095] The control circuitry 334 can adjust positions (e.g., incline and decline positions for the user 308 and/or an additional user of the bed 302) in response to user interactions with the bed 302. For example, the control circuitry 334 can cause the articulation controller to adjust the bed 302 to a first recline position for the user 308 in response to sensing user bed presence for the user 308. The control circuitry 334 can cause the articulation controller to adjust the bed 302 to a second recline position (e.g., a

less reclined, or flat position) in response to determining that the user 308 is asleep. As another example, the control circuitry 334 can receive a communication from the television 312 indicating that the user 308 has turned off the television 312, and in response the control circuitry 334 can cause the articulation controller to adjust the position of the bed 302 to a preferred user sleeping position (e.g., due to the user turning off the television 312 while the user 308 is in bed indicating that the user 308 wishes to go to sleep).

[0096] In some implementations, the control circuitry 334 can control the articulation controller so as to wake up one user of the bed 302 without waking another user of the bed 302. For example, the user 308 and a second user of the bed 302 can each set distinct wakeup times (e.g., 6:30am and 7:15am respectively). When the wakeup time for the user 308 is reached, the control circuitry 334 can cause the articulation controller to vibrate or change the position of only a side of the bed on which the user 308 is located to wake the user 308 without disturbing the second user. When the wakeup time for the second user is reached, the control circuitry 334 can cause the articulation controller to vibrate or change the position of only the side of the bed on which the second user is located. Alternatively, when the second wakeup time occurs, the control circuitry 334 can utilize other methods (such as audio alarms, or turning on the lights) to wake the second user since the user 308 is already awake and therefore will not be disturbed when the control circuitry 334 attempts to wake the second user.

[0097] Still referring to FIG. 3, the control circuitry 334 for the bed 302 can utilize information for interactions with the bed 302 by multiple users to generate control signals for controlling functions of various other devices. For example, the control circuitry 334 can wait to generate control signals for, for example, engaging the security system 318, or instructing the lighting system 314 to turn off lights in various rooms until both the user 308 and a second user are detected as being present on the bed 302. As another example, the control circuitry 334 can generate a first set of control signals to cause the lighting system 314 to turn off a first set of lights upon detecting bed presence of the user 308 and generate a second set of control signals for turning off a second set of lights in response to detecting bed presence of a second user. As another example, the control circuitry 334 can wait until it has been determined that both the user 308 and a

second user are awake for the day before generating control signals to open the window blinds 330. As yet another example, in response to determining that the user 308 has left the bed and is awake for the day, but that a second user is still sleeping, the control circuitry 334 can generate and transmit a first set of control signals to cause the coffee maker 324 to begin brewing coffee, to cause the security system 318 to deactivate, to turn on the lamp 326, to turn off the nightlight 328, to cause the thermostat 316 to raise the temperature in one or more rooms to 72 degrees, and to open blinds (e.g., the window blinds 330) in rooms other than the bedroom in which the bed 302 is located. Later, in response to detecting that the second user is no longer present on the bed (or that the second user is awake) the control circuitry 334 can generate and transmit a second set of control signals to, for example, cause the lighting system 314 to turn on one or more lights in the bedroom, to cause window blinds in the bedroom to open, and to turn on the television 312 to a pre-specified channel.

[0098] Examples of Data Processing Systems Associated with a Bed

[0099] Described here are examples of systems and components that can be used for data processing tasks that are, for example, associated with a bed. In some cases, multiple examples of a particular component or group of components are presented.

Some of these examples are redundant and/or mutually exclusive alternatives.

Connections between components are shown as examples to illustrate possible network configurations for allowing communication between components. Different formats of connections can be used as technically needed or desired. The connections generally indicate a logical connection that can be created with any technologically feasible format. For example, a network on a motherboard can be created with a printed circuit board, wireless data connections, and/or other types of network connections. Some logical connections are not shown for clarity. For example, connections with power supplies and/or computer readable memory may not be shown for clarity sake, as many or all elements of a particular component may need to be connected to the power supplies and/or computer readable memory.

[00100] FIG. 4A is a block diagram of an example of a data processing system 400 that can be associated with a bed system, including those described above with respect to FIGS. 1-3. This system 400 includes a pump motherboard 402 and a pump

daughterboard 404. The system 400 includes a sensor array 406 that can include one or more sensors configured to sense physical phenomenon of the environment and/or bed, and to report such sensing back to the pump motherboard 402 for, for example, analysis. The system 400 also includes a controller array 408 that can include one or more controllers configured to control logic-controlled devices of the bed and/or environment. The pump motherboard 400 can be in communication with one or more computing devices 414 and one or more cloud services 410 over local networks, the Internet 412, or otherwise as is technically appropriate. Each of these components will be described in more detail, some with multiple example configurations, below.

[00101] In this example, a pump motherboard 402 and a pump daughterboard 404 are communicably coupled. They can be conceptually described as a center or hub of the system 400, with the other components conceptually described as spokes of the system 400. In some configurations, this can mean that each of the spoke components communicates primarily or exclusively with the pump motherboard 402. For example, a sensor of the sensor array may not be configured to, or may not be able to, communicate directly with a corresponding controller. Instead, each spoke component can communicate with the motherboard 402. The sensor of the sensor array 406 can report a sensor reading to the motherboard 402, and the motherboard 402 can determine that, in response, a controller of the controller array 408 should adjust some parameters of a logic controlled device or otherwise modify a state of one or more peripheral devices. In one case, if the temperature of the bed is determined to be too hot, the pump motherboard 402 can determine that a temperature controller should cool the bed.

[00102] One advantage of a hub-and-spoke network configuration, sometimes also referred to as a star-shaped network, is a reduction in network traffic compared to, for example, a mesh network with dynamic routing. If a particular sensor generates a large, continuous stream of traffic, that traffic may only be transmitted over one spoke of the network to the motherboard 402. The motherboard 402 can, for example, marshal that data and condense it to a smaller data format for retransmission for storage in a cloud service 410. Additionally or alternatively, the motherboard 402 can generate a single, small, command message to be sent down a different spoke of the network in response to the large stream. For example, if the large stream of data is a pressure reading that is

transmitted from the sensor array 406 a few times a second, the motherboard 402 can respond with a single command message to the controller array to increase the pressure in an air chamber. In this case, the single command message can be orders of magnitude smaller than the stream of pressure readings.

[00103] As another advantage, a hub-and-spoke network configuration can allow for an extensible network that can accommodate components being added, removed, failing, etc. This can allow, for example, more, fewer, or different sensors in the sensor array 406, controllers in the controller array 408, computing devices 414, and/or cloud services 410. For example, if a particular sensor fails or is deprecated by a newer version of the sensor, the system 400 can be configured such that only the motherboard 402 needs to be updated about the replacement sensor. This can allow, for example, product differentiation where the same motherboard 402 can support an entry level product with fewer sensors and controllers, a higher value product with more sensors and controllers, and customer personalization where a customer can add their own selected components to the system 400.

[00104] Additionally, a line of air bed products can use the system 400 with different components. In an application in which every air bed in the product line includes both a central logic unit and a pump, the motherboard 402 (and optionally the daughterboard 404) can be designed to fit within a single, universal housing. Then, for each upgrade of the product in the product line, additional sensors, controllers, cloud services, etc., can be added. Design, manufacturing, and testing time can be reduced by designing all products in a product line from this base, compared to a product line in which each product has a bespoke logic control system.

[00105] Each of the components discussed above can be realized in a wide variety of technologies and configurations. Below, some examples of each component will be further discussed. In some alternatives, two or more of the components of the system 400 can be realized in a single alternative component; some components can be realized in multiple, separate components; and/or some functionality can be provided by different components.

[00106] FIG. 4B is a block diagram showing some communication paths of the data processing system 400. As previously described, the motherboard 402 and the pump

daughterboard 404 may act as a hub for peripheral devices and cloud services of the system 400. In cases in which the pump daughterboard 404 communicates with cloud services or other components, communications from the pump daughterboard 404 may be routed through the pump motherboard 402. This may allow, for example, the bed to have only a single connection with the internet 412. The computing device 414 may also have a connection to the internet 412, possibly through the same gateway used by the bed and/or possibly through a different gateway (e.g., a cell service provider).

[00107] Previously, a number of cloud services 410 were described. As shown in FIG. 4B, some cloud services, such as cloud services 410d and 410e, may be configured such that the pump motherboard 402 can communicate with the cloud service directly – that is the motherboard 402 may communicate with a cloud service 410 without having to use another cloud service 410 as an intermediary. Additionally or alternatively, some cloud services 410, for example cloud service 410f, may only be reachable by the pump motherboard 402 through an intermediary cloud service, for example cloud service 410e. While not shown here, some cloud services 410 may be reachable either directly or indirectly by the pump motherboard 402.

[00108] Additionally, some or all of the cloud services 410 may be configured to communicate with other cloud services. This communication may include the transfer of data and/or remote function calls according to any technologically appropriate format. For example, one cloud service 410 may request a copy for another cloud service's 410 data, for example, for purposes of backup, coordination, migration, or for performance of calculations or data mining. In another example, many cloud services 410 may contain data that is indexed according to specific users tracked by the user account cloud 410c and/or the bed data cloud 410a. These cloud services 410 may communicate with the user account cloud 410c and/or the bed data cloud 410a when accessing data specific to a particular user or bed.

[00109] FIG. 5 is a block diagram of an example of a motherboard 402 that can be used in a data processing system that can be associated with a bed system, including those described above with respect to FIGS. 1-3. In this example, compared to other examples described below, this motherboard 402 consists of relatively fewer parts and can be limited to provide a relatively limited feature set.

[00110] The motherboard includes a power supply 500, a processor 502, and computer memory 512. In general, the power supply includes hardware used to receive electrical power from an outside source and supply it to components of the motherboard 402. The power supply can include, for example, a battery pack and/or wall outlet adapter, an AC to DC converter, a DC to AC converter, a power conditioner, a capacitor bank, and/or one or more interfaces for providing power in the current type, voltage, etc., needed by other components of the motherboard 402.

[00111] The processor 502 is generally a device for receiving input, performing logical determinations, and providing output. The processor 502 can be a central processing unit, a microprocessor, general purpose logic circuitry, application-specific integrated circuitry, a combination of these, and/or other hardware for performing the functionality needed.

[00112] The memory 512 is generally one or more devices for storing data. The memory 512 can include long term stable data storage (e.g., on a hard disk), short term unstable (e.g., on Random Access Memory) or any other technologically appropriate configuration.

[00113] The motherboard 402 includes a pump controller 504 and a pump motor 506. The pump controller 504 can receive commands from the processor 502 and, in response, control the function of the pump motor 506. For example, the pump controller 504 can receive, from the processor 502, a command to increase the pressure of an air chamber by 0.3 pounds per square inch (PSI). The pump controller 504, in response, engages a valve so that the pump motor 506 is configured to pump air into the selected air chamber, and can engage the pump motor 506 for a length of time that corresponds to 0.3 PSI or until a sensor indicates that pressure has been increased by 0.3 PSI. In an alternative configuration, the message can specify that the chamber should be inflated to a target PSI, and the pump controller 504 can engage the pump motor 506 until the target PSI is reached.

[00114] A valve solenoid 508 can control which air chamber a pump is connected to. In some cases, the solenoid 508 can be controlled by the processor 502 directly. In some cases, the solenoid 508 can be controlled by the pump controller 504.

[00115] A remote interface 510 of the motherboard 402 can allow the motherboard 402 to communicate with other components of a data processing system. For example, the motherboard 402 can be able to communicate with one or more daughterboards, with peripheral sensors, and/or with peripheral controllers through the remote interface 510. The remote interface 510 can provide any technologically appropriate communication interface, including but not limited to multiple communication interfaces such as WiFi, Bluetooth, and copper wired networks.

[00116] FIG. 6 is a block diagram of an example of a motherboard 402 that can be used in a data processing system that can be associated with a bed system, including those described above with respect to FIGS. 1-3. Compared to the motherboard 402 described with reference to FIG. 5, the motherboard in FIG. 6 can contain more components and provide more functionality in some applications.

[00117] In addition to the power supply 500, processor 502, pump controller 504, pump motor 506, and valve solenoid 508, this motherboard 402 is shown with a valve controller 600, a pressure sensor 602, a universal serial bus (USB) stack 604, a WiFi radio 606, a Bluetooth Low Energy (BLE) radio 608, a ZigBee radio 610, a Bluetooth radio 612 and a computer memory 512.

[00118] Similar to the way that the pump controller 504 converts commands from the processor 502 into control signals for the pump motor 506, the valve controller 600 can convert commands from the processor 502 into control signals for the valve solenoid 508. In one example, the processor 502 can issue a command to the valve controller 600 to connect the pump to a particular air chamber out of the group of air chambers in an air bed. The valve controller 600 can control the position of the valve solenoid 508 so that the pump is connected to the indicated air chamber.

[00119] The pressure sensor 602 can read pressure readings from one or more air chambers of the air bed. The pressure sensor 602 can also preform digital sensor conditioning.

[00120] The motherboard 402 can include a suite of network interfaces, including but not limited to those shown here. These network interfaces can allow the motherboard to communicate over a wired or wireless network with any number of devices, including

but not limited to peripheral sensors, peripheral controllers, computing devices, and devices and services connected to the Internet 412.

[00121] FIG 7 is a block diagram of an example of a daughterboard 404 that can be used in a data processing system that can be associated with a bed system, including those described above with respect to FIGS. 1-3. In some configurations, one or more daughterboards 404 can be connected to the motherboard 402. Some daughterboards 404 can be designed to offload particular and/or compartmentalized tasks from the motherboard 402. This can be advantageous, for example, if the particular tasks are computationally intensive, proprietary, or subject to future revisions. For example, the daughterboard 404 can be used to calculate a particular sleep data metric. This metric can be computationally intensive, and calculating the sleep metric on the daughterboard 404 can free up the resources of the motherboard 402 while the metric is being calculated. Additionally and/or alternatively, the sleep metric can be subject to future revisions. To update the system 400 with the new sleep metric, it is possible that only the daughterboard 404 that calculates that metric need be replaced. In this case, the same motherboard 402 and other components can be used, saving the need to perform unit testing of additional components instead of just the daughterboard 404.

[00122] The daughterboard 404 is shown with a power supply 700, a processor 702, computer readable memory 704, a pressure sensor 706, and a WiFi radio 708. The processor can use the pressure sensor 706 to gather information about the pressure of the air chamber or chambers of an air bed. From this data, the processor 702 can perform an algorithm to calculate a sleep metric. In some examples, the sleep metric can be calculated from only the pressure of air chambers. In other examples, the sleep metric can be calculated from one or more other sensors. In an example in which different data is needed, the processor 702 can receive that data from an appropriate sensor or sensors. These sensors can be internal to the daughterboard 404, accessible via the WiFi radio 708, or otherwise in communication with the processor 702. Once the sleep metric is calculated, the processor 702 can report that sleep metric to, for example, the motherboard 402.

[00123] FIG 8 is a block diagram of an example of a motherboard 800 with no daughterboard that can be used in a data processing system that can be associated with a

bed system, including those described above with respect to FIGS. 1-3. In this example, the motherboard 800 can perform most, all, or more of the features described with reference to the motherboard 402 in FIG. 6 and the daughterboard 404 in FIG. 7.

[00124] FIG. 9 is a block diagram of an example of a sensory array 406 that can be used in a data processing system that can be associated with a bed system, including those described above with respect to FIGS. 1-3. In general, the sensor array 406 is a conceptual grouping of some or all the peripheral sensors that communicate with the motherboard 402 but are not native to the motherboard 402.

[00125] The peripheral sensors of the sensor array 406 can communicate with the motherboard 402 through one or more of the network interfaces of the motherboard, including but not limited to the USB stack 1112, a WiFi radio 606, a Bluetooth Low Energy (BLE) radio 608, a ZigBee radio 610, and a Bluetooth radio 612, as is appropriate for the configuration of the particular sensor. For example, a sensor that outputs a reading over a USB cable can communicate through the USB stack 1112.

[00126] Some of the peripheral sensors 900 of the sensor array 406 can be bed mounted 900. These sensors can be, for example, embedded into the structure of a bed and sold with the bed, or later affixed to the structure of the bed. Other peripheral sensors 902 and 904 can be in communication with the motherboard 402, but optionally not mounted to the bed. In some cases, some or all of the bed mounted sensors 900 and/or peripheral sensors 902 and 904 can share networking hardware, including a conduit that contains wires from each sensor, a multi-wire cable or plug that, when affixed to the motherboard 402, connect all of the associated sensors with the motherboard 402. In some embodiments, one, some, or all of sensors 902, 904, 906, 908, and 910 can sense one or more features of a mattress, such as pressure, temperature, light, sound, and/or one or more other features of the mattress. In some embodiments, one, some, or all of sensors 902, 904, 906, 908, and 910 can sense one or more features external to the mattress. In some embodiments, pressure sensor 902 can sense pressure of the mattress while some or all of sensors 902, 904, 906, 908, and 910 can sense one or more features of the mattress and/or external to the mattress.

[00127] FIG. 10 is a block diagram of an example of a controller array 408 that can be used in a data processing system that can be associated with a bed system, including

those described above with respect to FIGS. 1-3. In general, the controller array 408 is a conceptual grouping of some or all peripheral controllers that communicate with the motherboard 402 but are not native to the motherboard 402.

[00128] The peripheral controllers of the controller array 408 can communicate with the motherboard 402 through one or more of the network interfaces of the motherboard, including but not limited to the USB stack 1112, a WiFi radio 1114, a Bluetooth Low Energy (BLE) radio 1116, a ZigBee radio 610, and a Bluetooth radio 612, as is appropriate for the configuration of the particular sensor. For example, a controller that receives a command over a USB cable can communicate through the USB stack 1112.

[00129] Some of the controllers of the controller array 408 can be bed mounted 1000, including but not limited to a temperature controller 1006, a light controller 1008, and/or a speaker controller 1010. These controllers can be, for example, embedded into the structure of a bed and sold with the bed, or later affixed to the structure of the bed. Other peripheral controllers 1002 and 1004 can be in communication with the motherboard 402, but optionally not mounted to the bed. In some cases, some or all of the bed mounted controllers 1000 and/or peripheral controllers 1002 and 1004 can share networking hardware, including a conduit that contains wires for each controller, a multi-wire cable or plug that, when affixed to the motherboard 402, connects all of the associated controllers with the motherboard 402.

[00130] FIG. 11 is a block diagram of an example of a computing device 414 that can be used in a data processing system that can be associated with a bed system, including those described above with respect to FIGS. 1-3. The computing device 414 can include, for example, computing devices used by a user of a bed. Example computing devices 414 include, but are not limited to, mobile computing devices (e.g., mobile phones, tablet computers, laptops) and desktop computers.

[00131] The computing device 414 includes a power supply 1100, a processor 1102, and computer readable memory 1104. User input and output can be transmitted by, for example, speakers 1106, a touchscreen 1108, or other not shown components such as a pointing device or keyboard. The computing device 414 can run one or more applications 1110. These applications can include, for example, application to allow the

user to interact with the system 400. These applications can allow a user to view information about the bed (e.g., sensor readings, sleep metrics), or configure the behavior of the system 400 (e.g., set a desired firmness to the bed, set desired behavior for peripheral devices). In some cases, the computing device 414 can be used in addition to, or to replace, the remote control 122 described previously.

[00132] FIG. 12 is a block diagram of an example bed data cloud service 410a that can be used in a data processing system that can be associated with a bed system, including those described above with respect to FIGS. 1-3. In this example, the bed data cloud service 410a is configured to collect sensor data and sleep data from a particular bed, and to match the sensor and sleep data with one or more users that use the bed when the sensor and sleep data was generated.

[00133] The bed data cloud service 410a is shown with a network interface 1200, a communication manager 1202, server hardware 1204, and server system software 1206. In addition, the bed data cloud service 410a is shown with a user identification module 1208, a device management 1210 module, a sensor data module 1212, and an advanced sleep data module 1214.

[00134] The network interface 1200 generally includes hardware and low level software used to allow one or more hardware devices to communicate over networks. For example the network interface 1200 can include network cards, routers, modems, and other hardware needed to allow the components of the bed data cloud service 410a to communicate with each other and other destinations over, for example, the Internet 412. The communication manger 1202 generally comprises hardware and software that operate above the network interface 1200. This includes software to initiate, maintain, and tear down network communications used by the bed data cloud service 410a. This includes, for example, TCP/IP, SSL or TLS, Torrent, and other communication sessions over local or wide area networks. The communication manger 1202 can also provide load balancing and other services to other elements of the bed data cloud service 410a.

[00135] The server hardware 1204 generally includes the physical processing devices used to instantiate and maintain bed data cloud service 410a. This hardware includes, but is not limited to processors (e.g., central processing units, ASICs, graphical processors), and computer readable memory (e.g., random access memory, stable hard

disks, tape backup). One or more servers can be configured into clusters, multi-computer, or datacenters that can be geographically separate or connected.

[00136] The server system software 1206 generally includes software that runs on the server hardware 1204 to provide operating environments to applications and services. The server system software 1206 can include operating systems running on real servers, virtual machines instantiated on real servers to create many virtual servers, server level operations such as data migration, redundancy, and backup.

[00137] The user identification 1208 can include, or reference, data related to users of beds with associated data processing systems. For example, the users can include customers, owners, or other users registered with the bed data cloud service 410a or another service. Each user can have, for example, a unique identifier, user credentials, contact information, billing information, demographic information, or any other technologically appropriate information.

[00138] The device manager 1210 can include, or reference, data related to beds or other products associated with data processing systems. For example, the beds can include products sold or registered with a system associated with the bed data cloud service 410a. Each bed can have, for example, a unique identifier, model and/or serial number, sales information, geographic information, delivery information, a listing of associated sensors and control peripherals, etc. Additionally, an index or indexes stored by the bed data cloud service 410a can identify users that are associated with beds. For example, this index can record sales of a bed to a user, users that sleep in a bed, etc.

[00139] The sensor data 1212 can record raw or condensed sensor data recorded by beds with associated data processing systems. For example, a bed's data processing system can have a temperature sensor, pressure sensor, and light sensor. Readings from these sensors, either in raw form or in a format generated from the raw data (e.g. sleep metrics) of the sensors, can be communicated by the bed's data processing system to the bed data cloud service 410a for storage in the sensor data 1212. Additionally, an index or indexes stored by the bed data cloud service 410a can identify users and/or beds that are associated with the sensor data 1212.

[00140] The bed data cloud service 410a can use any of its available data to generate advanced sleep data 1214. In general, the advanced sleep data 1214 includes

sleep metrics and other data generated from sensor readings. Some of these calculations can be performed in the bed data cloud service 410a instead of locally on the bed's data processing system, for example, because the calculations are computationally complex or require a large amount of memory space or processor power that is not available on the bed's data processing system. This can help allow a bed system to operate with a relatively simple controller and still be part of a system that performs relatively complex tasks and computations.

[00141] FIG. 13 is a block diagram of an example sleep data cloud service 410b that can be used in a data processing system that can be associated with a bed system, including those described above with respect to FIGS. 1-3. In this example, the sleep data cloud service 410b is configured to record data related to users' sleep experience.

[00142] The sleep data cloud service 410b is shown with a network interface 1300, a communication manager 1302, server hardware 1304, and server system software 1306. In addition, the sleep data cloud service 410b is shown with a user identification module 1308, a pressure sensor manager 1310, a pressure based sleep data module 1312, a raw pressure sensor data module 1314, and a non-pressure sleep data module 1316.

[00143] The pressure sensor manager 1310 can include, or reference, data related to the configuration and operation of pressure sensors in beds. For example, this data can include an identifier of the types of sensors in a particular bed, their settings and calibration data, etc.

[00144] The pressure based sleep data 1312 can use raw pressure sensor data 1314 to calculate sleep metrics specifically tied to pressure sensor data. For example, user presence, movements, weight change, heart rate, and breathing rate can all be determined from raw pressure sensor data 1314. Additionally, an index or indexes stored by the sleep data cloud service 410b can identify users that are associated with pressure sensors, raw pressure sensor data, and/or pressure based sleep data.

[00145] The non-pressure sleep data 1316 can use other sources of data to calculate sleep metrics. For example, user entered preferences, light sensor readings, and sound sensor readings can all be used to track sleep data. Additionally, an index or indexes stored by the sleep data cloud service 410b can identify users that are associated with other sensors and/or non-pressure sleep data 1316.

[00146] FIG. 14 is a block diagram of an example user account cloud service 410c that can be used in a data processing system that can be associated with a bed system, including those described above with respect to FIGS. 1-3. In this example, the user account cloud service 410c is configured to record a list of users and to identify other data related to those users.

[00147] The user account cloud service 410c is shown with a network interface 1400, a communication manager 1402, server hardware 1404, and server system software 1406. In addition, the user account cloud service 410c is shown with a user identification module 1408, a purchase history module 1410, an engagement module 1412, and an application usage history module 1414.

[00148] The user identification module 1408 can include, or reference, data related to users of beds with associated data processing systems. For example, the users can include customers, owners, or other users registered with the user account cloud service 410a or another service. Each user can have, for example, a unique identifier, and user credentials, demographic information, or any other technologically appropriate information.

[00149] The purchase history module 1410 can include, or reference, data related to purchases by users. For example, the purchase data can include a sale's contact information, billing information, and salesperson information. Additionally, an index or indexes stored by the user account cloud service 410c can identify users that are associated with a purchase.

[00150] The engagement 1412 can track user interactions with the manufacturer, vendor, and/or manager of the bed and or cloud services. This engagement data can include communications (e.g., emails, service calls), data from sales (e.g., sales receipts, configuration logs), and social network interactions.

[00151] The usage history module 1414 can contain data about user interactions with one or more applications and/or remote controls of a bed. For example, a monitoring and configuration application can be distributed to run on, for example, computing devices 412. This application can log and report user interactions for storage in the application usage history module 1414. Additionally, an index or indexes stored by

the user account cloud service 410c can identify users that are associated with each log entry.

[00152] FIG. 15 is a block diagram of an example point of sale cloud service 1500 that can be used in a data processing system that can be associated with a bed system, including those described above with respect to FIGS. 1-3. In this example, the point of sale cloud service 1500 is configured to record data related to users' purchases.

[00153] The point of sale cloud service 1500 is shown with a network interface 1502, a communication manager 1504, server hardware 1506, and server system software 1508. In addition, the point of sale cloud service 1500 is shown with a user identification module 1510, a purchase history module 1512, and a setup module 1514.

[00154] The purchase history module 1512 can include, or reference, data related to purchases made by users identified in the user identification module 1510. The purchase information can include, for example, data of a sale, price, and location of sale, delivery address, and configuration options selected by the users at the time of sale. These configuration options can include selections made by the user about how they wish their newly purchased beds to be setup and can include, for example, expected sleep schedule, a listing of peripheral sensors and controllers that they have or will install, etc.

[00155] The bed setup module 1514 can include, or reference, data related to installations of beds that users' purchase. The bed setup data can include, for example, the date and address to which a bed is delivered, the person that accepts delivery, the configuration that is applied to the bed upon delivery, the name or names of the person or people who will sleep on the bed, which side of the bed each person will use, etc.

[00156] Data recorded in the point of sale cloud service 1500 can be referenced by a user's bed system at later dates to control functionality of the bed system and/or to send control signals to peripheral components according to data recorded in the point of sale cloud service 1500. This can allow a salesperson to collect information from the user at the point of sale that later facilitates automation of the bed system. In some examples, some or all aspects of the bed system can be automated with little or no user-entered data required after the point of sale. In other examples, data recorded in the point of sale cloud service 1500 can be used in connection with a variety of additional data gathered from user-entered data.

[00157] FIG. 16 is a block diagram of an example environment cloud service 1600 that can be used in a data processing system that can be associated with a bed system, including those described above with respect to FIGS. 1-3. In this example, the environment cloud service 1600 is configured to record data related to users' home environment.

[00158] The environment cloud service 1600 is shown with a network interface 1602, a communication manager 1604, server hardware 1606, and server system software 1608. In addition, the environment cloud service 1600 is shown with a user identification module 1610, an environmental sensor module 1612, and an environmental factors module 1614.

[00159] The environmental sensors module 1612 can include a listing of sensors that users' in the user identification module 1610 have installed in their bed. These sensors include any sensors that can detect environmental variables – light sensors, noise sensors, vibration sensors, thermostats, etc. Additionally, the environmental sensors module 1612 can store historical readings or reports from those sensors.

[00160] The environmental factors module 1614 can include reports generated based on data in the environmental sensors module 1612. For example, for a user with a light sensor with data in the environment sensors module 1612, the environmental factors module 1614 can hold a report indicating the frequency and duration of instances of increased lighting when the user is asleep.

[00161] In the examples discussed here, each cloud service 410 is shown with some of the same components. In various configurations, these same components can be partially or wholly shared between services, or they can be separate. In some configurations, each service can have separate copies of some or all of the components that are the same or different in some ways. Additionally, these components are only supplied as illustrative examples. In other examples each cloud service can have different number, types, and styles of components that are technically possible.

[00162] FIG. 17 is a block diagram of an example of using a data processing system that can be associated with a bed (such as a bed of the bed systems described herein) to automate peripherals around the bed. Shown here is a behavior analysis module 1700 that runs on the pump motherboard 402. For example, the behavior

analysis module 1700 can be one or more software components stored on the computer memory 512 and executed by the processor 502. In general, the behavior analysis module 1700 can collect data from a wide variety of sources (e.g., sensors, non-sensor local sources, cloud data services) and use a behavioral algorithm 1702 to generate one or more actions to be taken (e.g., commands to send to peripheral controllers, data to send to cloud services). This can be useful, for example, in tracking user behavior and automating devices in communication with the user's bed.

[00163] The behavior analysis module 1700 can collect data from any technologically appropriate source, for example, to gather data about features of a bed, the bed's environment, and/or the bed's users. Some such sources include any of the sensors of the sensor array 406. For example, this data can provide the behavior analysis module 1700 with information about the current state of the environment around the bed. For example, the behavior analysis module 1700 can access readings from the pressure sensor 902 to determine the pressure of an air chamber in the bed. From this reading, and potentially other data, user presence in the bed can be determined. In another example, the behavior analysis module can access a light sensor 908 to detect the amount of light in the bed's environment.

[00164] Similarly, the behavior analysis module 1700 can access data from cloud services. For example, the behavior analysis module 1700 can access the bed cloud service 410a to access historical sensor data 1212 and/or advanced sleep data 1214. Other cloud services 410, including those not previously described can be accessed by the behavior analysis module 1700. For example, the behavior analysis module 1700 can access a weather reporting service, a 3rd party data provider (e.g., traffic and news data, emergency broadcast data, user travel data), and/or a clock and calendar service.

[00165] Similarly, the behavior analysis module 1700 can access data from non-sensor sources 1704. For example, the behavior analysis module 1700 can access a local clock and calendar service (e.g., a component of the motherboard 402 or of the processor 502).

[00166] The behavior analysis module 1700 can aggregate and prepare this data for use by one or more behavioral algorithms 1702. The behavioral algorithms 1702 can be used to learn a user's behavior and/or to perform some action based on the state of the

accessed data and/or the predicted user behavior. For example, the behavior algorithm 1702 can use available data (e.g., pressure sensor, non-sensor data, clock and calendar data) to create a model of when a user goes to bed every night. Later, the same or a different behavioral algorithm 1702 can be used to determine if an increase in air chamber pressure is likely to indicate a user going to bed and, if so, send some data to a third-party cloud service 410 and/or engage a device such as a pump controller 504, foundation actuators 1706, temperature controller 1008, under-bed lighting 1010, a peripheral controller 1002, or a peripheral controller 1004, to name a few.

[00167] In the example shown, the behavioral analysis module 1700 and the behavioral algorithm 1702 are shown as components of the motherboard 402. However, other configurations are possible. For example, the same or a similar behavioral analysis module and/or behavior algorithm can be run in one or more cloud services, and the resulting output can be sent to the motherboard 402, a controller in the controller array 408, or to any other technologically appropriate recipient.

[00168] FIG. 18 shows an example of a computing device 1800 and an example of a mobile computing device that can be used to implement the techniques described here. The computing device 1800 is intended to represent various forms of digital computers, such as laptops, desktops, workstations, personal digital assistants, servers, blade servers, mainframes, and other appropriate computers. The mobile computing device is intended to represent various forms of mobile devices, such as personal digital assistants, cellular telephones, smart-phones, and other similar computing devices. The components shown here, their connections and relationships, and their functions, are meant to be exemplary only, and are not meant to limit implementations of the inventions described and/or claimed in this document.

[00169] The computing device 1800 includes a processor 1802, a memory 1804, a storage device 1806, a high-speed interface 1808 connecting to the memory 1804 and multiple high-speed expansion ports 1810, and a low-speed interface 1812 connecting to a low-speed expansion port 1814 and the storage device 1806. Each of the processor 1802, the memory 1804, the storage device 1806, the high-speed interface 1808, the high-speed expansion ports 1810, and the low-speed interface 1812, are interconnected using various busses, and can be mounted on a common motherboard or in other manners as

appropriate. The processor 1802 can process instructions for execution within the computing device 1800, including instructions stored in the memory 1804 or on the storage device 1806 to display graphical information for a GUI on an external input/output device, such as a display 1816 coupled to the high-speed interface 1808. In other implementations, multiple processors and/or multiple buses can be used, as appropriate, along with multiple memories and types of memory. Also, multiple computing devices can be connected, with each device providing portions of the necessary operations (e.g., as a server bank, a group of blade servers, or a multi-processor system).

[00170] The memory 1804 stores information within the computing device 1800. In some implementations, the memory 1804 is a volatile memory unit or units. In some implementations, the memory 1804 is a non-volatile memory unit or units. The memory 1804 can also be another form of computer-readable medium, such as a magnetic or optical disk.

[00171] The storage device 1806 is capable of providing mass storage for the computing device 1800. In some implementations, the storage device 1806 can be or contain a computer-readable medium, such as a floppy disk device, a hard disk device, an optical disk device, or a tape device, a flash memory or other similar solid state memory device, or an array of devices, including devices in a storage area network or other configurations. A computer program product can be tangibly embodied in an information carrier. The computer program product can also contain instructions that, when executed, perform one or more methods, such as those described above. The computer program product can also be tangibly embodied in a computer- or machine-readable medium, such as the memory 1804, the storage device 1806, or memory on the processor 1802.

[00172] The high-speed interface 1808 manages bandwidth-intensive operations for the computing device 1800, while the low-speed interface 1812 manages lower bandwidth-intensive operations. Such allocation of functions is exemplary only. In some implementations, the high-speed interface 1808 is coupled to the memory 1804, the display 1816 (e.g., through a graphics processor or accelerator), and to the high-speed expansion ports 1810, which can accept various expansion cards (not shown). In the implementation, the low-speed interface 1812 is coupled to the storage device 1806 and

the low-speed expansion port 1814. The low-speed expansion port 1814, which can include various communication ports (e.g., USB, Bluetooth, Ethernet, wireless Ethernet) can be coupled to one or more input/output devices, such as a keyboard, a pointing device, a scanner, or a networking device such as a switch or router, e.g., through a network adapter.

[00173] The computing device 1800 can be implemented in a number of different forms, as shown in the figure. For example, it can be implemented as a standard server 1820, or multiple times in a group of such servers. In addition, it can be implemented in a personal computer such as a laptop computer 1822. It can also be implemented as part of a rack server system 1824. Alternatively, components from the computing device 1800 can be combined with other components in a mobile device (not shown), such as a mobile computing device 1850. Each of such devices can contain one or more of the computing device 1800 and the mobile computing device 1850, and an entire system can be made up of multiple computing devices communicating with each other.

[00174] The mobile computing device 1850 includes a processor 1852, a memory 1864, an input/output device such as a display 1854, a communication interface 1866, and a transceiver 1868, among other components. The mobile computing device 1850 can also be provided with a storage device, such as a micro-drive or other device, to provide additional storage. Each of the processor 1852, the memory 1864, the display 1854, the communication interface 1866, and the transceiver 1868, are interconnected using various buses, and several of the components can be mounted on a common motherboard or in other manners as appropriate.

[00175] The processor 1852 can execute instructions within the mobile computing device 1850, including instructions stored in the memory 1864. The processor 1852 can be implemented as a chipset of chips that include separate and multiple analog and digital processors. The processor 1852 can provide, for example, for coordination of the other components of the mobile computing device 1850, such as control of user interfaces, applications run by the mobile computing device 1850, and wireless communication by the mobile computing device 1850.

[00176] The processor 1852 can communicate with a user through a control interface 1858 and a display interface 1856 coupled to the display 1854. The display

1854 can be, for example, a TFT (Thin-Film-Transistor Liquid Crystal Display) display or an OLED (Organic Light Emitting Diode) display, or other appropriate display technology. The display interface 1856 can comprise appropriate circuitry for driving the display 1854 to present graphical and other information to a user. The control interface 1858 can receive commands from a user and convert them for submission to the processor 1852. In addition, an external interface 1862 can provide communication with the processor 1852, so as to enable near area communication of the mobile computing device 1850 with other devices. The external interface 1862 can provide, for example, for wired communication in some implementations, or for wireless communication in other implementations, and multiple interfaces can also be used.

[00177] The memory 1864 stores information within the mobile computing device 1850. The memory 1864 can be implemented as one or more of a computer-readable medium or media, a volatile memory unit or units, or a non-volatile memory unit or units. An expansion memory 1874 can also be provided and connected to the mobile computing device 1850 through an expansion interface 1872, which can include, for example, a SIMM (Single In Line Memory Module) card interface. The expansion memory 1874 can provide extra storage space for the mobile computing device 1850, or can also store applications or other information for the mobile computing device 1850. Specifically, the expansion memory 1874 can include instructions to carry out or supplement the processes described above, and can include secure information also. Thus, for example, the expansion memory 1874 can be provide as a security module for the mobile computing device 1850, and can be programmed with instructions that permit secure use of the mobile computing device 1850. In addition, secure applications can be provided via the SIMM cards, along with additional information, such as placing identifying information on the SIMM card in a non-hackable manner.

[00178] The memory can include, for example, flash memory and/or NVRAM memory (non-volatile random access memory), as discussed below. In some implementations, a computer program product is tangibly embodied in an information carrier. The computer program product contains instructions that, when executed, perform one or more methods, such as those described above. The computer program product can be a computer- or machine-readable medium, such as the memory 1864, the

expansion memory 1874, or memory on the processor 1852. In some implementations, the computer program product can be received in a propagated signal, for example, over the transceiver 1868 or the external interface 1862.

[00179] The mobile computing device 1850 can communicate wirelessly through the communication interface 1866, which can include digital signal processing circuitry where necessary. The communication interface 1866 can provide for communications under various modes or protocols, such as GSM voice calls (Global System for Mobile communications), SMS (Short Message Service), EMS (Enhanced Messaging Service), or MMS messaging (Multimedia Messaging Service), CDMA (code division multiple access), TDMA (time division multiple access), PDC (Personal Digital Cellular), WCDMA (Wideband Code Division Multiple Access), CDMA2000, or GPRS (General Packet Radio Service), among others. Such communication can occur, for example, through the transceiver 1868 using a radio-frequency. In addition, short-range communication can occur, such as using a Bluetooth, WiFi, or other such transceiver (not shown). In addition, a GPS (Global Positioning System) receiver module 1870 can provide additional navigation- and location-related wireless data to the mobile computing device 1850, which can be used as appropriate by applications running on the mobile computing device 1850.

[00180] The mobile computing device 1850 can also communicate audibly using an audio codec 1860, which can receive spoken information from a user and convert it to usable digital information. The audio codec 1860 can likewise generate audible sound for a user, such as through a speaker, e.g., in a handset of the mobile computing device 1850. Such sound can include sound from voice telephone calls, can include recorded sound (e.g., voice messages, music files, etc.) and can also include sound generated by applications operating on the mobile computing device 1850.

[00181] The mobile computing device 1850 can be implemented in a number of different forms, as shown in the figure. For example, it can be implemented as a cellular telephone 1880. It can also be implemented as part of a smart-phone 1882, personal digital assistant, or other similar mobile device.

[00182] Various implementations of the systems and techniques described here can be realized in digital electronic circuitry, integrated circuitry, specially designed ASICs

(application specific integrated circuits), computer hardware, firmware, software, and/or combinations thereof. These various implementations can include implementation in one or more computer programs that are executable and/or interpretable on a programmable system including at least one programmable processor, which can be special or general purpose, coupled to receive data and instructions from, and to transmit data and instructions to, a storage system, at least one input device, and at least one output device.

[00183] These computer programs (also known as programs, software, software applications or code) include machine instructions for a programmable processor, and can be implemented in a high-level procedural and/or object-oriented programming language, and/or in assembly/machine language. As used herein, the terms machine-readable medium and computer-readable medium refer to any computer program product, apparatus and/or device (e.g., magnetic discs, optical disks, memory, Programmable Logic Devices (PLDs)) used to provide machine instructions and/or data to a programmable processor, including a machine-readable medium that receives machine instructions as a machine-readable signal. The term machine-readable signal refers to any signal used to provide machine instructions and/or data to a programmable processor.

[00184] To provide for interaction with a user, the systems and techniques described here can be implemented on a computer having a display device (e.g., a CRT (cathode ray tube) or LCD (liquid crystal display) monitor) for displaying information to the user and a keyboard and a pointing device (e.g., a mouse or a trackball) by which the user can provide input to the computer. Other kinds of devices can be used to provide for interaction with a user as well; for example, feedback provided to the user can be any form of sensory feedback (e.g., visual feedback, auditory feedback, or tactile feedback); and input from the user can be received in any form, including acoustic, speech, or tactile input.

[00185] The systems and techniques described here can be implemented in a computing system that includes a backend component (e.g., as a data server), or that includes a middleware component (e.g., an application server), or that includes a frontend component (e.g., a client computer having a graphical user interface or a Web browser through which a user can interact with an implementation of the systems and techniques described here), or any combination of such backend, middleware, or frontend

components. The components of the system can be interconnected by any form or medium of digital data communication (e.g., a communication network). Examples of communication networks include a local area network (LAN), a wide area network (WAN), and the Internet.

[00186] The computing system can include clients and servers. A client and server are generally remote from each other and typically interact through a communication network. The relationship of client and server arises by virtue of computer programs running on the respective computers and having a client-server relationship to each other.

[00187] FIG. 19 is block diagram of an example system 1900 for home automation. The system 1900 includes a device 1902, a computational cloud 1904, a user interface (UI) 1906, a bed sensor 1908, and a sleep datastore 1910.

[00188] The device 1902 can include a controller of a bed or home automation such as a hub, computer, or dedicated controller. Some dedicated controllers are voice-activated, allowing the user to issue voice commands and receive audio feedback. The device 1902 can receive output signals from the bed sensor 1908, generate from the output signals, information about presence (e.g., pressure variations) in a bed, and can process the generated information to identify sleep parameters of a sleeper or sleepers in the bed.

[00189] The sleep parameters can include all, any, or a combination of the following: bed state (e.g., in bed or out of bed,) biometric values (physical motion, cardiac action like heart rate and variability, respiration action like respiration rate,) sleep stage (e.g., N1, N2, REM, falling asleep, in deep sleep,) sleepers position (e.g., on side, on back, curled,) sleep onset (e.g., time to fall asleep.) The client processing can include any, all, or some of the following features: a digital filter such as a band-pass filter, a time series analysis element, a model-based element, a source separation element such as an independent component analysis (ICA,) a wavelet transform, a spectral analysis element, a detrending analysis element, a pattern-matching element, a threshold-based analysis element, a linear or non-linear interpolation element to compute a surrogate index, and/or a machine learning element.

[00190] The computational cloud 1904 can include computing resources that provide one or more services to other elements of the system 1900. The computational

cloud 1904 can receive input, settings, commands, configurations, and/or status from network-connected devices such as a mobile-phone application, desktop application, or cloud-based application. The cloud 1904 can send inputs, settings, commands, configurations, and/or status received from devices to the client device 1902. The cloud 1904 can receive presence information (e.g., pressure) from the client device 1902 and process the generated information to identify, e.g., pressure trends or real time event related to the bed. The computational cloud 1904 can send the trends and events to the sleep database 1910 and can communicate with devices and applications to send or receive information, summaries, scores, events, notifications, charts, images, reports, commands, and decisions.

[00191] The cloud 1904 can include artificial intelligence (AI) features that are configured to access the other elements of the system and to identify patterns, links, correlations, causations, and/or associations between data, to calculate quantitative values (e.g., sleep score or health score) or to generate qualitative sleep insight messages, to derive trends, to build personalized and population level models, and to make inferences from the data. The interfaces can include, but are not limited to: i) identifying sleep factors that negatively impact sleep quality such as sleep interruptions (for example, frequent bed exits or long out of bed times in the middle of the sleep), excessive motion and restlessness, longer than usual time to fall asleep, not getting enough restful sleep, and increased sleep debt; ii) detecting if a user has difficulty falling asleep or difficulty staying asleep; iii) detecting biometrics and sleep health factor changes such as changes in sleep stages, heart rate, heart rate variability, breathing rate and motion; iv) detecting out-of-the-norm changes in sleep or health parameters with respect to the past history of the sleeper, v) detecting sleep and health disorders such as snoring, apnea, movement disorders, heart rate disorders, pain, stress, and teeth grinding; v) providing insights about sleeper's sleep and health (personalized tier), comparison against similar demographics such as sleepers of the same age, sex, and weight (comparable tier), and insights regarding geographic data such as sleepers from the same city, state, or country (population tier;) vi) accessing user data (alarms and calendar) to adjust wake up alarms based on optimal sleep duration and optimal sleep stages; vii) recommending sleep enhancement tips such as optimal time to go to bed, optimal position to start sleeping and

optimal sleep duration; and/or viii) recommending optimal bed and bedroom environment parameters such as optimal mattress firmness (adjusted using Sleep Number setting), optimal bed temperature and optimal bedroom temperature. Using the results of this AI analysis, the device 1902 can be configured to make automated changes to bed or bedroom features in order to enhance sleep.

[00192] The artificial intelligence component can combine inference and analytics to use the above inferences along with the sleepers' historic data in order to generate intelligent personalized sleep enhancement recommendations. This can include, but is not limited to messages such as i) "You slept x percent better than your monthly average. You had a restful night's sleep. Having a consistent routine helps regulate your body's clock and will further improve your sleep," ii) "Your sleep score was lower than your weekly average because you didn't get enough restful sleep. You need at least 7 hours of sleep for a restorative body and brain recovery," iii) "Your sleep was disrupted throughout the night. Try to minimize sleep interruptions for your body to have the opportunity to progress through the sleep stages to get the full restoration," iv) "We noticed that it took you longer to fall asleep, and you didn't get enough sleep. Try to have a consistent sleep routine and at least 7 hours of restful sleep for a restorative body and brain recovery," v) "You have been consistently sleeping less than your goal during the past month. We recommend adjusting your sleep goal and adhering to a consistent 7 or more hours sleep," vi) "We noticed that on weekdays, you always wake up at 6 am. In order to get a better night's sleep, adjust your routine so you can get in bed by 10 pm," vii) "We noticed that in winter, your sleep is less restful. Try reducing your bed's firmness setting for a more comfortable and restorative sleep," and/or viii) "You are sleeping better than other female sleepers of your age in California. We have adjusted your bed temperature during sleep last night so you can maximize your deep, REM and restful sleep."

[00193] The artificial intelligence component can use one or more classifiers or one or more regressors or a combination of both. The system can be configured to save the trained classifier, regressor and inference models in the cloud for future access. The classifiers can be unsupervised or supervised. For the unsupervised approach, clustering can be used to draw inferences from the input data without labels. Clustering can use any of the databases in the database unit and may include any, all, or a combination of the

following learning algorithms: K-means, mixture models, hierarchical clustering, self organizing maps, and hidden markov models. For the supervised approach, the classifier or regressor can use any of the databases in the database unit and may include any, all, or a combination of the following models: support vector machine, artificial neural network, decision tree and regression model. Supervised classification and regression can be organized into involve two major tasks - including training and testing.

[00194] Training can include i) obtaining a large set of pre-classified data, or annotating a large set of data; ii) generating one or more features; iii) combining or reducing the features; iii) processing the features; and/or iv) training the classifier or the regressor. Testing can include testing the model with subsets of the pre-classified data

[00195] The artificial intelligence component can be further configured to receive inputs from the UI 1906 and provide interactive personalized insights in order to guide the user through sleep enhancement options. For example, the user interface unit can display an option (such a slider bar) to change the value of one or more sleep parameters (such as sleep duration, time went to bed, or time took to fall asleep). The user can change the value of the one or more parameters, and the artificial intelligence component will determine the impact of the changed parameter on the sleep or health quality of the sleeper, and can provide an updated quantitative value (such as a sleep score or health score) or an updated message to reflect the impact of the change on sleep or health of the individual user.

[00196] The UI 1906 can be incorporated into a device such as a mobile phone, a computer, an automation hub, or any other technologically-appropriate device. The UI 1906 can operate in different modes such as an in-range communication mode (for example, via Bluetooth) and an out-of-range communication mode (for example, via Wifi network) for communicating inputs, settings, commands, configurations, or status to the client device 1902 and/or the computational cloud 1904, and for showing sleep information gathered or generated during sleep.

[00197] Sleep information can include a quantitative score (e.g., a health score or sleep quality score presented on a numeric scale or as a color,) one or more values of sleep and/or biometric parameters (e.g., sleep duration, motion, restful sleep duration, average heart rate, average breathing rate,) one or more sleep and/or health insights (e.g.,

sleep tips,) charts and graphs displaying sleep and health information from sleep time, and/or notifications.

[00198] The bed sensor 1908 can include a pressure transducer, a sensor pad, or another technologically appropriate device configured to sense user's body during sleep. For example, a pressure transducer can measure pressure variations during sleep from an air chamber of a mattress. The bed sensor 1908 can additionally include acoustic sensors and temperature sensors integrated within the bed system. For simplicity, the following descriptions will discuss only pressure, but other signals are used in similar fashion.

[00199] A sleep datastore 1910 can receive and store sleep information related to a sleeper of a bed.

[00200] Variations and expansions of the system 1900 are possible. FIG. 20 is a block diagram of an example system 2000 for home automation. The system 2000 includes the elements 1902-1910, as well as other datastores 2012 and 2014, other sensors 2016, and user-set information 2018.

[00201] The other datastores 2012 and 2014 can store and make available other data used by the system 2016.

[00202] The other sensors 2016 can communicate with the UI 1906 through one or more application program interfaces (APIs) that serve as an integration layer to request, access, retrieve, store, or modify data related to the other sensors 2016. Data transmitted through the APIs can include, but is not limited to user-data such as alarms, calendar events, personal medical history, and medication information. The data can also include, but is not limited to data sensed about the user and environment such as temperature readings, humidity, air-quality, exercise, steps, calories consumed or burned, weight, sound, light, user interactions with a device like a phone, health related data (from medical devices or non-medical devices) such as CPAPs, PPGs, SP02s, blood pressures, or blood sugars. The data can also include, but is not limited to, geographic data such as weather, lunar phase, humidity, heat index, wind, earthquake activity, and disease epidemics.

[00203] User-set information 2018 can include information set by a user in an application. This can include calendar information, alarms set to wake up the user, etc.

[00204] FIG. 21 is a flowchart of an example process 2100 for processing data. The process 2100 can be performed using, for example, the systems 1900 or 2000 and will be described using elements of these systems.

[00205] In the process 2100, the device 1902 sense 2102 data from the bed sensors 1908, can receive 2104 input from the UI 1906, can receive 2106 data from the cloud 1904, and can receive 2106 data from the other sensors 2016 or other peripheral devices.

[00206] With this data, the device 1902 can process this data to generate data that is sent 2112 to the cloud 1904 and/or sent 2114 to the UI 1906. The data transmissions may use network links of any technologically appropriate type including, but not limited to, Bluetooth, WiFi, copper wire, and fiber-optic media.

[00207] The processing 2110 can include any, all or a combination of the following: i) a digital filter such as a band-pass filter, ii) a time series analysis method, iii) a model-based method, iv) a source separation operation such as the independent component analysis (ICA), v) a wavelet transform, a spectral operation, vi) a detrending operation, vii) a pattern matching operation, viii) a threshold based operation, ix) a linear or nonlinear interpolation operation to compute a surrogate index, and/or x) a machine learning operation. Client actions taken by the device 1902 in response to the process 2100 can include adjustments to the adjustable features of the bed system or the bedroom environment.

[00208] FIG. 22 is a block diagram of an example process 2200 for processing data. The process 2200 can be performed by a cloud such as the cloud 1904, accessing the sleep datastore 1910 and an AI datastore 2202 that contains data related to AI operations of the cloud 1904. In the process 2200, the cloud receives 2204 data from the device 1902 and receive 2206 data from the UI 1906. The cloud also retrieves 2208 data and models from the datastores 1910 and 2202 for use in cloud processing 2210. The cloud processing 2210 can include identify patterns, links, correlation, causation and association between the data, calculate quantitative value (such as a sleep score or health score) or qualitative sleep insight message or tips, derive trends, build personalized and population learning models, and make inferences.

[00209] The cloud can prepare 2212 to store the data generated in the processing 2210 and the datastores 2202 and 1910 can store any of the data needed. In addition, the

cloud can prepare 2214 and transmit 2216 data to the devices 1902 and transmit 2218 data to the UI 1906.

[00210] FIG. 23 is a block diagram of an example process 2300 for processing data. The process 2300 can be performed by a cloud such as the cloud 1904, accessing the sleep datastore 1910, the AI datastore 2202, and another datastore 2012. In the process 2300, the cloud receives 2204 data from the device 1902, receive 2206 data from the UI 1906, and receives 2320 data from one or more API sources. The cloud also retrieves 2208 data and models from the datastores 1910, 2202, and 2012 for use in cloud processing 2210. The cloud processing 2210 can include identify patterns, links, correlation, causation and association between the data, calculate quantitative value (such as a sleep score or health score) or qualitative sleep insight message or tips, derive trends, build personalized and population learning models, and make inferences.

[00211] The cloud can prepare 2212 to store the data generated in the processing 2210 and the datastores 2202 and 1910 can store any of the data needed. In addition, the cloud can prepare 2214 and transmit 2216 data to the devices 1902 and transmit 2218 data to the UI 1906.

[00212] FIG. 24 is a flowchart of an example process 2400 for receiving and sending data. The process 2400 can be performed by, for example, a UI device such as the UI 1906. The UI can operate both in in-range and out-of-range modes, for sending/receiving inputs, settings, commands, configurations or status from WiFi devices to/from the cloud 1904 and/or device 1902 an operate to display sleep information from one or more sleep sessions.

[00213] Sleep information can be a quantitative score (such as a sleep score or a health score), one or more values of sleep and biometric parameters (such as sleep duration, motion, restful sleep duration, average heart rate, average breathing rate, etc.), one or more sleep and health insights (such as sleep tips), charts and graphs displaying the sleep and health information during sleep, and notifications.

[00214] The process 2400 includes receiving 2402 data from the device 1902 and receiving 2404 data from the cloud 1904. The UI displays 2406 information (e.g., number, graphs, colored indicators) and controls (e.g., buttons, sliders, input-boxes) and sends 2408 data to the device 1902 and sends 2410 data to the cloud 2410.

[00215] FIG. 25 is a flowchart of an example process 2500 for receiving and sending data. The process 2500 can be performed by, for example, a UI device such as the UI 1906. The UI can operate both in in-range and out-of-range modes, for sending/receiving inputs, settings, commands, configurations or status from WiFi devices to/from the cloud 1904 and/or device 1902 and operate to display sleep information from one or more sleep sessions.

[00216] Sleep information can be a quantitative score (such as a sleep score or a health score), one or more values of sleep and biometric parameters (such as sleep duration, motion, restful sleep duration, average heart rate, average breathing rate, etc.), one or more sleep and health insights (such as sleep tips), charts and graphs displaying the sleep and health information during sleep, and notifications.

[00217] The process 2400 includes receiving 2402 data from the device 1902, receiving 2404 data from the cloud 1904, and receiving 2512 data from the APIs. The UI displays 2406 information (e.g., number, graphs, colored indicators) and controls (e.g., buttons, sliders, input-boxes) and sends 2408 data to the device 1902 and sends 2410 data to the cloud 2410.

[00218] Communication from 2512 the APIs can include messages to request, access, retrieve, store, or modify data other than what is provided by the bed system. The messages can also send the data received from the API to the cloud unit. This data includes i) user data such as alarms, calendar events, personal medical history, medications, ii) sensory data such as temperature readings, humidity, air quality, exercise, steps, calories, weight, sound, light, user interaction with phone, and health related data such as CPAP, PPG, SPO2, blood pressure and blood sugar; iii) geographical data stores such as weather, lunar phase, humidity, heat index, wind, earthquake, and disease epidemics, etc.

[00219] FIG. 26 is a flowchart of an example process 2600 for home automation. The process can be performed by, for example, elements of the systems 1900 and/or the system 2000. In the process 2600, selected data sent from the client is processed and is written to the sleep database. Also in the process 2600, the data in the sleep database is retrieved and used in the AI processing component to learn individualized trends and make inferences including comparison of real-time data against trend data to identify

correlations, causations, associations and out-of-the-norm patterns. The inference output is then used to (i) make adjustments to the adjustable features of the bed system if the sleeper is in bed (i.e. personalized sleep enhancement) or (ii) to provide individualized recommendations and insights if the sleeper is out of bed.

[00220] Data is received 2602 from a client device. For example, a client device can access data from one or more sensors to identify parameters of the user while the user sleeps. These parameters may include measures of the user directly (e.g., movement, biological activity) or of the environment the user is in (e.g., bed firmness, ambient temperature, temperature of the bed.)

[00221] Data is processed 2604 for analysis. For example, a strict subset of all available data may be identified and used for analysis, while other data is not used for analysis. Data that is identified may include data that was previously identified as useful for determining sleep quality or providing insights or automated behavior that is designed to improve the user's sleep. These determinations include, but are not limited to, the result of machine learning processes performed for the user or on population and subpopulation studies.

[00222] Data is processed 2606. For example, aggregate values can be made from larger data sets of raw values, biometric or other values can be extracted from signal analysis of one or more sets of raw values, etc. In general, the sets raw values may be larger than the processed data, allowing for a more advantageously efficient process that can be performed with existing hardware. Further, processing can extract signal from noise in sets of raw data. For example, cardiac action can be extracted from raw pressure readings of a bed, and beats-per-minute can be extracted from the data of cardiac action.

[00223] Data is written 2608 to a sleep datastore. For example, the processed data can be written to a sleep datastore for use later in the process 2600.

[00224] Individual trends are received learned 2610 from received 2609 data from the sleep datastore. For example, trends that are unique to a single user (e.g., no matter what bed the user sleeps on, and not co-mingled with other user's data) may be analyzed with AI operations in order to identify trends that are individually learned. For example, a user with a particularly low body temperature (e.g., due to undergoing adaptive thermogenesis due to healthy weight loss or just normal biological variation) would have

a very different set of trends than the population of all users, all users of the same weight, etc. Similarly, a user with a particularly high body temperature (e.g., due to a metabolic response to a particularly taxing workout every night before bed or due to taking a cold shower before bed or just normal biological variation) would also have a very different set of trends than the population of all users, all users of the same weight, etc. Learning 2610 individualized trends allows the process 2600 to provide useful data for these users as well as those users more typical of the population at large or similar sub-populations.

[00225] Real-time data is compared 2612 with trend data 2612. For example, actual data measured for a current sleep session is compared with trend information learned 2610 for the user, the user's subpopulation, and/or the population at large. A goodness-of-fit between the real-time data and the trend data may be found, and the goodness-of-fit can be used as a measure of how close or how far away from an ideal sleep environment and experience the user is receiving in the current sleep session.

[00226] If the sleeper is not in bed 2614, the user can be provided 2620 with personalized recommendations and/or insights. For example, one or more parameters contributing to a poor goodness-of-fit can be identified, and insight related to that parameter can be provided. This may be direct advice where the user is suggested to change a parameter directly, such as "your bedroom has been bright, be sure to turn off the lights when you go to bed." This may be indirect advice, where the user is suggested to change a parameter indirectly through a change to another aspect of their sleep, such as "You have been restless recently. Why don't you try sleeping on your back tonight to see if that helps you relax more and move around less."

[00227] If the sleeper is in bed 2614, a time to make adjustments to the user's bed and/or environment is determined 2616. For example, a user may be benefited by a reduction in bed firmness, but to avoid waking the user when they are only lightly asleep, it may be determined 2614 that the pressure of the bed should be changed when REM sleep is entered. These times determined may be based on clock times (e.g., 11:45 PM,) sleep events (e.g., entering a sleep stage) or event based (e.g., when a loud noise is detected, play a white-noise to reduce the impact of the loud nose.)

[00228] An adjustment is made 2618. For example, a bed controller can send one or more instructions to one or more components or peripheral devices at the determined time to cause the adjustment identified.

[00229] FIG. 27 is a flowchart of an example process 2700 for home automation. The process can be performed by, for example, elements of the systems 1900 and/or the system 2000. In the process 2000, sleep data and automation commands are used to provide personalized enhancements. For clarity, this process is being described with reference to a particular set of components. However, other system or systems can be used to perform the same or a similar process.

[00230] In the process 2700, data sent from the client will be processed and saved to the sleep database. Data from other sensors other than the bed system (temperature readings, humidity, air quality, exercise, steps, calories, weight, sound, light, user interaction with phone, and health related data such as CPAP, PPG, SPO2, blood pressure and blood sugar) and data from other databases other than sleep and AI databases (weather, lunar phase, humidity, heat index, wind, earthquake, and disease epidemics) can be used to enhance real-time client data. For example, if the temperature data points to settings for times when no one is in the house, then the real-time bed state client data is forced to be “out-of-bed”. In another example, when the weather database shows an extreme increase in the temperature, the real-time client data can be post-processed with updated thresholds, parameters, settings or patterns to provide a more accurate analysis of the pressure readings from the client.

[00231] The data in the sleep database can be retrieved and together with the enhanced client data be used in the AI processing component to learn individualized trends and make inferences including comparison of real-time data against trend data to identify correlations, causations, associations and out-of-the-norm patterns. The inference output is then used to (i) make adjustments to the adjustable features of the bed system if the sleeper is in bed (i.e. personalized sleep enhancement) or (ii) to provide individualized recommendations and insights if the sleeper is out of bed. Examples include: i) identifying sleep factors that negatively impact sleep quality such as sleep interruptions (for example, frequent bed exits or long out of bed times in the middle of the sleep), excessive motion and restlessness, longer than usual time to fall asleep, not

getting enough restful sleep, and increased sleep debt; ii) detecting if someone has difficulty falling asleep or difficulty staying asleep; iii) detecting biometrics and sleep health factor changes such as changes in sleep stages, heart rate, heart rate variability, breathing rate and motion; iv) detecting out-of-the-norm changes in sleep or health parameters with respect to the past history of the sleeper; v) detecting sleep and health disorders such as snoring, apnea, movement disorders, heart rate disorders, pain, stress, and teeth grinding, etc.

[00232] In the process 2700, AI processing 2610 and 2612 can include data received 2722 and 2724 from other datastores. This data can include any sort of technically appropriate data that might influence a user's sleep experience such as weather, geographical, or scheduling data. Data can be enhanced 2726 to tie sleep data with non-sleep data. For example, timestamps on sleep data and non-sleep data may be normalized so that cotemporaneous data may have the same time-stamps, allowing the AI to more robustly identify trends in the data.

[00233] Correlations in sleep data and non-sleep data may be identified 2728. For example, as opposed to more sophisticated – and often resource intensive – processing, comparatively simple correlations may be identified. For example, for a large percentage of the population, noises above a particular threshold (e.g., a very loud bang of 135 decibels) awakens almost any user. In less extreme examples, a simple correlation may exist between temperatures within normal-room temperature and sleep quality.

[00234] Using client data, sleep data, and user-set data, the process 2700 can determine 2730 if an adjustment to the user-set data would be beneficial. For example, if a user has been getting less sleep or less-restful sleep, a change to an early morning meeting scheduled in their calendar or an early alarm may be beneficially changed.

[00235] If the user is not yet in bed 2614, a suggestion can be made to the user. For example, a message such as “Your first meeting is not until 10:00 AM, would you like your alarm moved back 30 minutes to help you catch up on sleep?” can be given to the user, optionally with an interface element (a button) to make the change suggested.

[00236] If the user is already in bed 2614, the process 2700 can perform different actions depending on if the user has given permissions for automatic adjustment to user-set data. If the user has not provided permission 2616, the process 2700 can make

adjustments 2618 to the user's sleep environment. If the user has provided permission 2616, the process can adjust the user-set data 2736 (optionally with additional adjustments to the sleep environment.) For example, since the user would already be asleep and not able to act on the suggestion to move the alarm back 30 minutes, and if the user has given explicitly permission to adjust the alarm, the process 2700 can adjust 2736 the user's alarm. In other situations, user-data that can be adjusted includes meetings scheduled in a calendar, ordering of items in a to-do list, etc.

[00237] FIG. 28 is a flowchart of an example process 2800 for control of a graphic user interface. The process 2800 can be used to provide interactive personalized insights to a user based on data generated about a user's sleep. The user interface unit can be configured to get changes to the value of one or more sleep parameters from the user (for example, by displaying a slider bar to change the value of one or more sleep parameters). The UI unit can then send the acquired values (i.e. user changes) to the cloud unit so that the AI component can determine the impact of the changed parameter on the sleep or health quality of the sleeper. The AI component will then provide an updated quantitative value (such as a sleep score or health score) or an updated message to reflect the impact of the change on sleep or health of the individual user. This will get sent back to the UI unit and the display will be updated with the updated information.

[00238] Information is displayed 2802. For example, a night's sleep quality score is provided to a user via a GUI, along with a list of factors that influenced the score. The factors each have associated a GUI control element (e.g., a slider, an entry in a drop-down list) by which the user can enter data. By default, the actual values for each of these factors is shown. As will be shown, manipulation of the control element causes data for a new, hypothetical sleep session to be shown along with the hypothetical sleep metric or metrics for that hypothetical sleep session.

[00239] User change is received 2804. For example, to understand the influence of heat on her sleep, a user may adjust the interface element for the heat parameter from the actual reading of 68F to 72F.

[00240] User changes are sent to the cloud 2806 and user changes are received at the cloud 2808. For example, the new parameters for the hypothetical night (in this case

the same as the real night except the heat value) are sent to the cloud where they are parsed and ready for use.

[00241] AI processing is performed 2810. For example, the hypothetical parameters are processed using the same AI processing that is used to generate sleep metrics for real sleep sessions. In addition, the corresponding real sleep parameters may be sent and processed, so that relative information may be tracked. Example relative information may take the form of “improvement of 3%” or “better.”

[00242] Updated information is sent 2812. For example, the new sleep metric for the hypothetical night and/or the relative information may be displayed to the user in a graphical user interface, such as that shown in FIG. 29.

WHAT IS CLAIMED IS:

1. A system comprising:
 - a bed having a mattress;
 - a sensor configured to sense sleep readings of a user sleeping on the bed;
 - an automation controller configured to transmit the sleep readings to a cloud service;
 - hardware hosting the cloud service configured to compare the sleep readings with trend data in order to generate adjustments to the user's sleep environment.
2. The system of claim 1, wherein:
 - the cloud service is further configured to transmit the adjustments to the automation controller.
3. The system of claim 2, wherein:
 - the automation controller is further configured to, responsive to receiving the adjustments, determine if the user is in the bed.
4. The system of claim 3, wherein:
 - after determining that the user is not in the bed, provide information to the user via a GUI based on the adjustments.
5. The system of claim 3 wherein:
 - after determining that the user is in the bed, cause an automation to influence the user's sleep environment according to the adjustments.
6. The system of claim 3, wherein:
 - after determining that the user is in the bed, cause a change to user-data according to the adjustments.
7. Method performed by the system of one of the claims 1-6.

8. Computer-readable media containing instructions to cause machines to perform the method of claim 7.
9. A system comprising:
 - a bed having a mattress;
 - a sensor configured to sense sleep readings of a user sleeping on the bed;
 - an automation controller configured to:
 - transmit the sleep readings to a cloud service; and
 - receive, from the cloud service, instructions to modify the user's sleep environment; and
 - hardware hosting the cloud service configured to:
 - compare the sleep readings with personalized trend data generated from historical sensing of the user's sleep in order to generate adjustments to the user's sleep environment that are personalized for the user.
10. The system of claim 9, wherein the sensor configured to sense sleep readings of a user sleeping on the bed is integral to the bed, and wherein the system further comprises:
 - an interface device configured to display a user interface (UI) configured to receive data input from a user;
 - a datastore storing historic user sleep data; and
 - a peripheral sensor that is not integral to the bed and that is configured to sense an element of the user's sleep environment as peripheral data.
11. The system of claim 10, wherein the hardware hosting the cloud service is further configured to:
 - incorporate the data input, the historical user sleep data, and the peripheral data in the generation of adjustments.
12. The system of claim 10, wherein the automation controller is one of the group consisting of a bed-controller, a pump-controller, and a voice-activated home-automation controller.

13. The system of claim 10, wherein the adjustments include machine-readable instructions for one of the group consisting of the bed and a peripheral device.
14. The system of claim 10, wherein the adjustment include human-readable suggestions to the user.
15. A system comprising:
 - a bed having a mattress;
 - a sensor configured to sense sleep readings of a user sleeping on the bed;
 - an automation controller configured to:
 - transmit the sleep readings to a cloud service;
 - receive, from the cloud service, instructions to deliver human-readable suggestions to the user that include personalized recommendations generated as a function of the sleep readings of the user; and
 - cause the human-readable suggestions that include personalized recommendations to be delivered to the user.



1/30

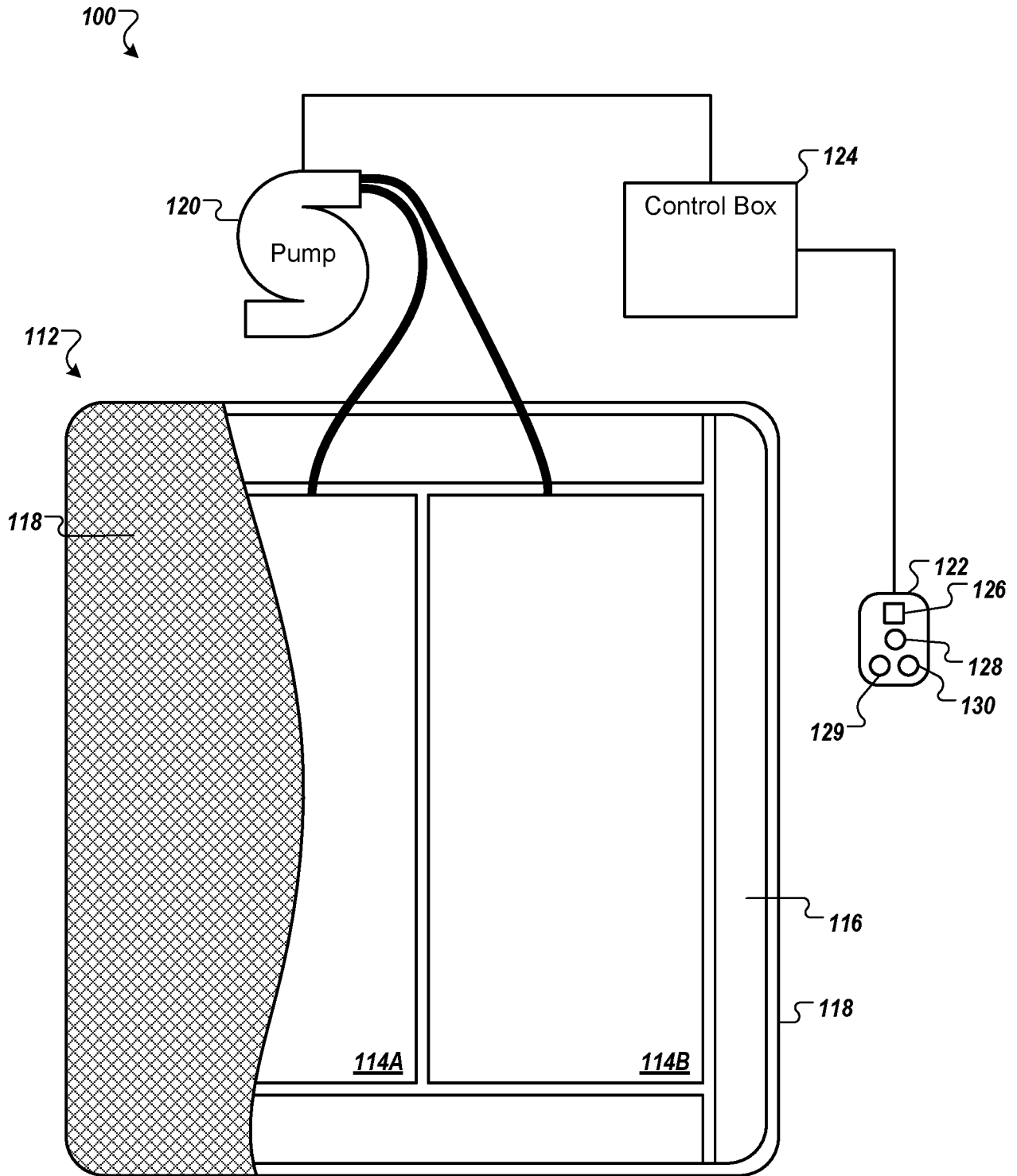

FIG. 1



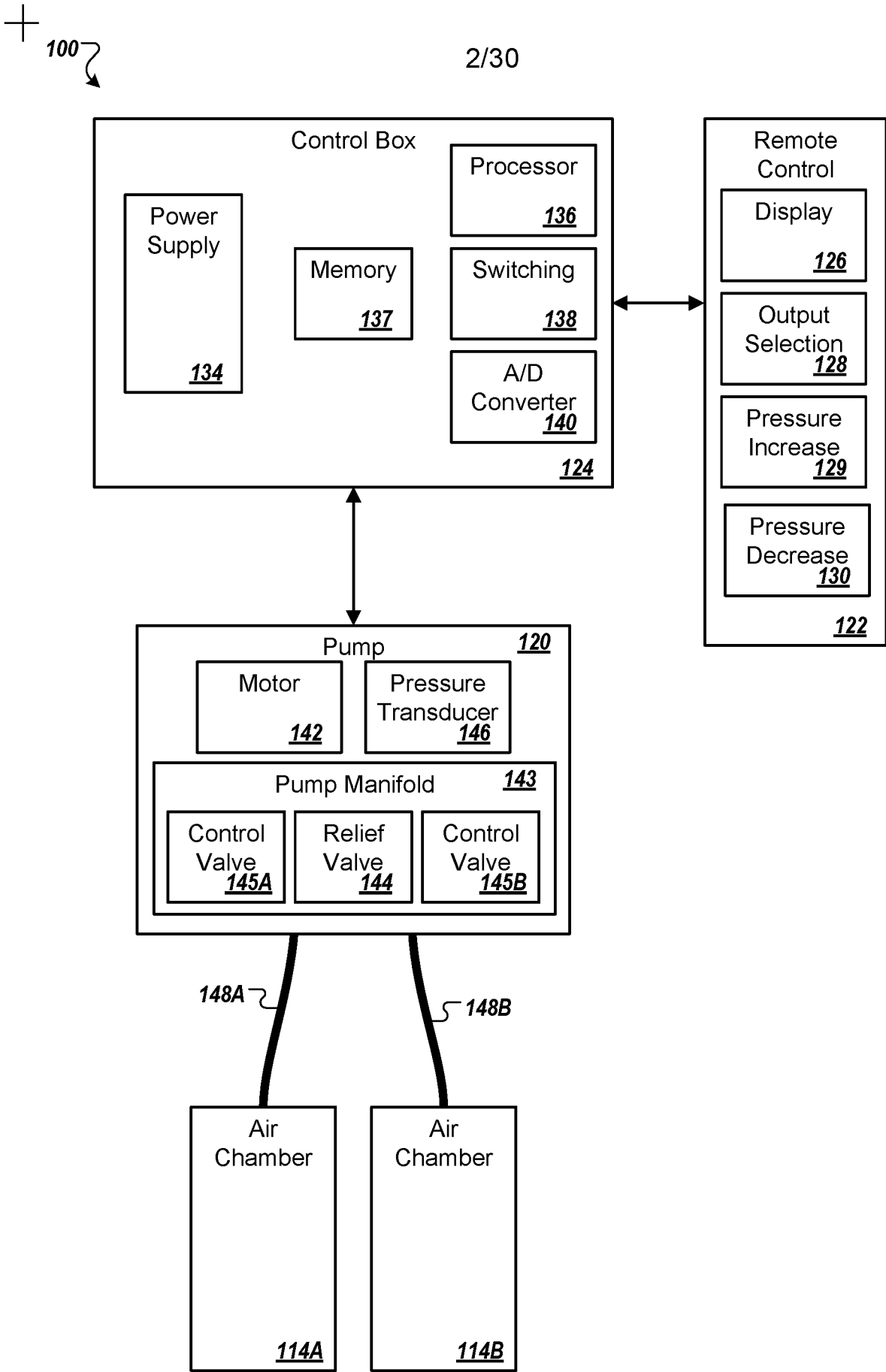

FIG. 2

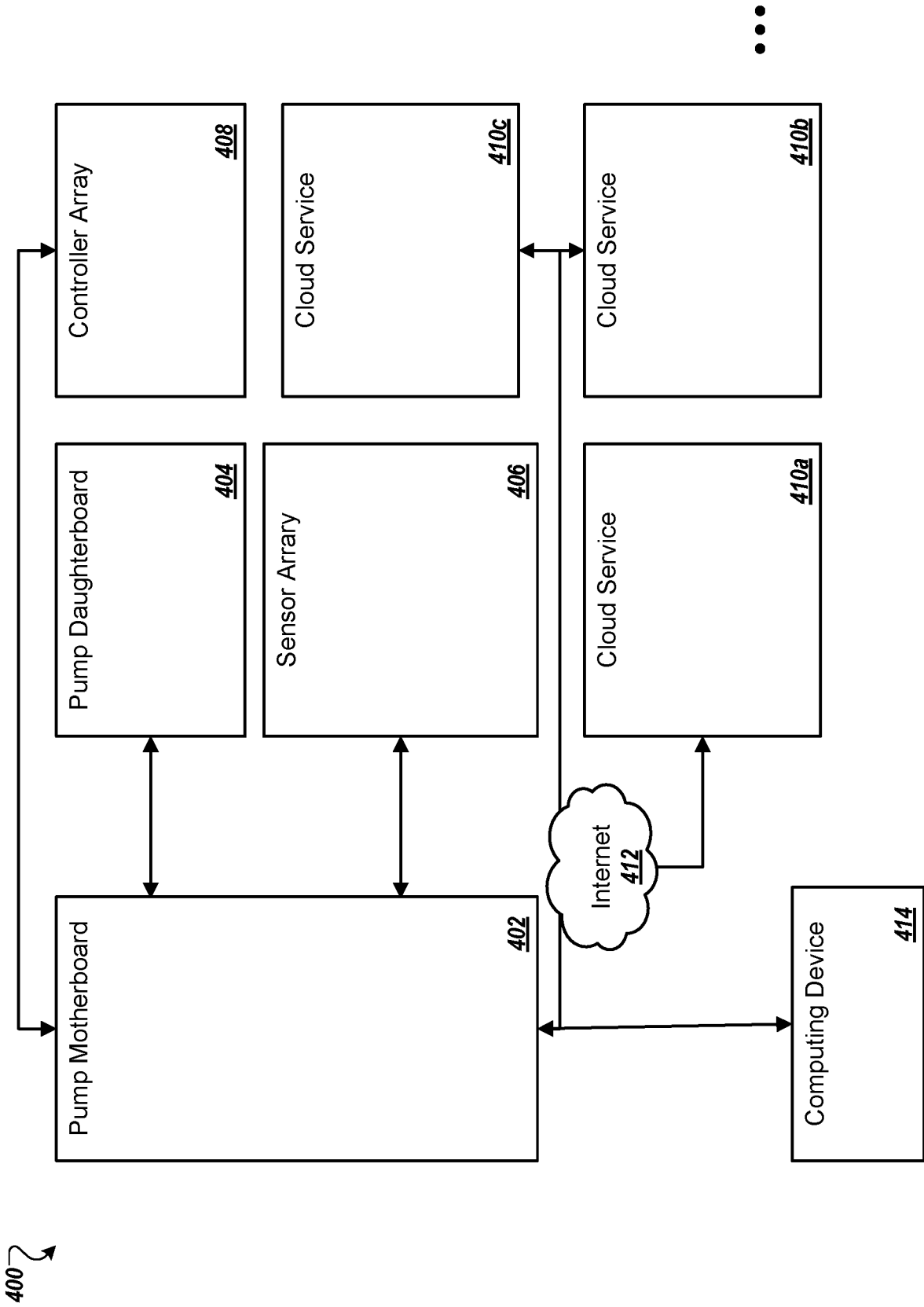

FIG. 4A





5/30

400 ↷

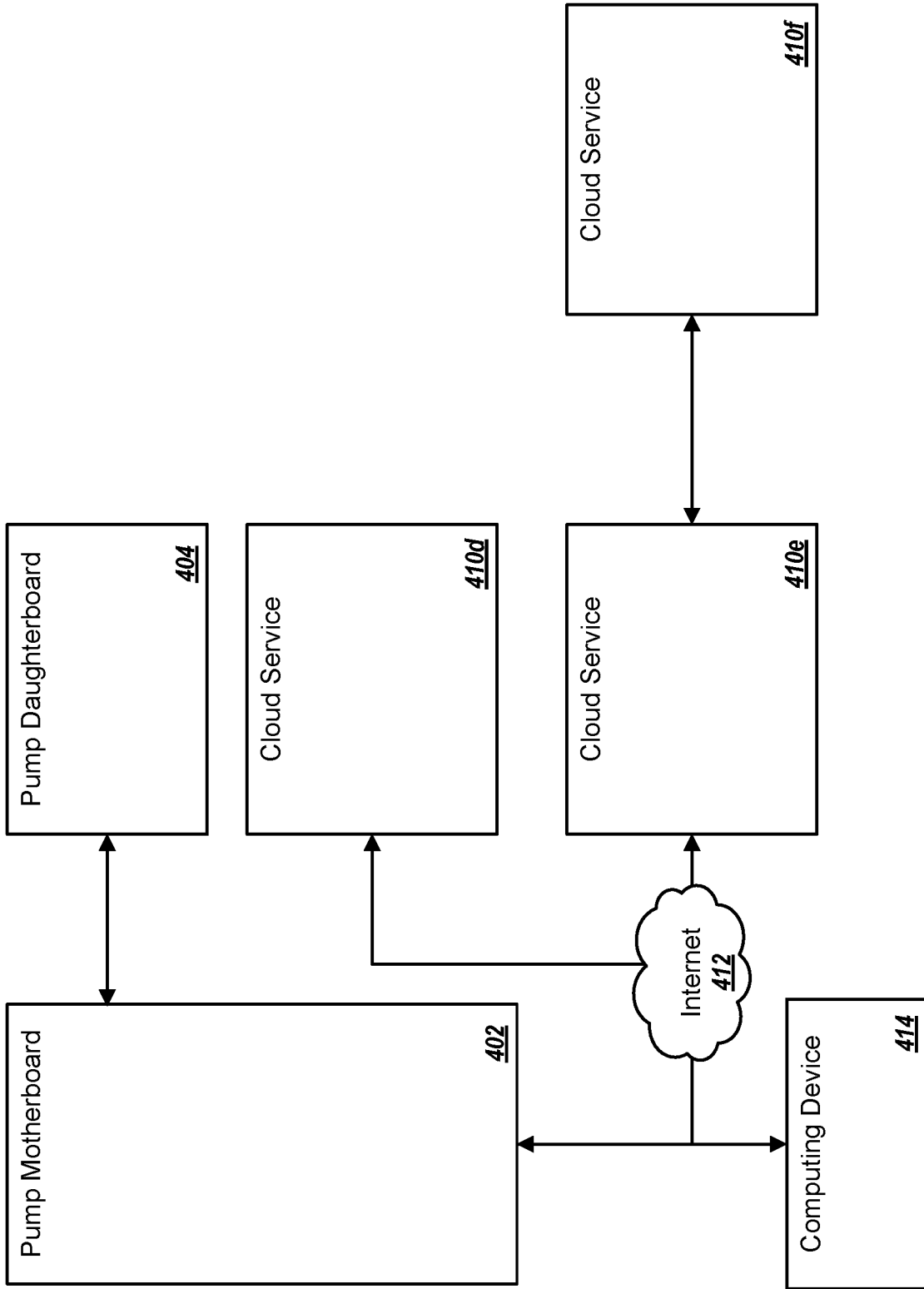
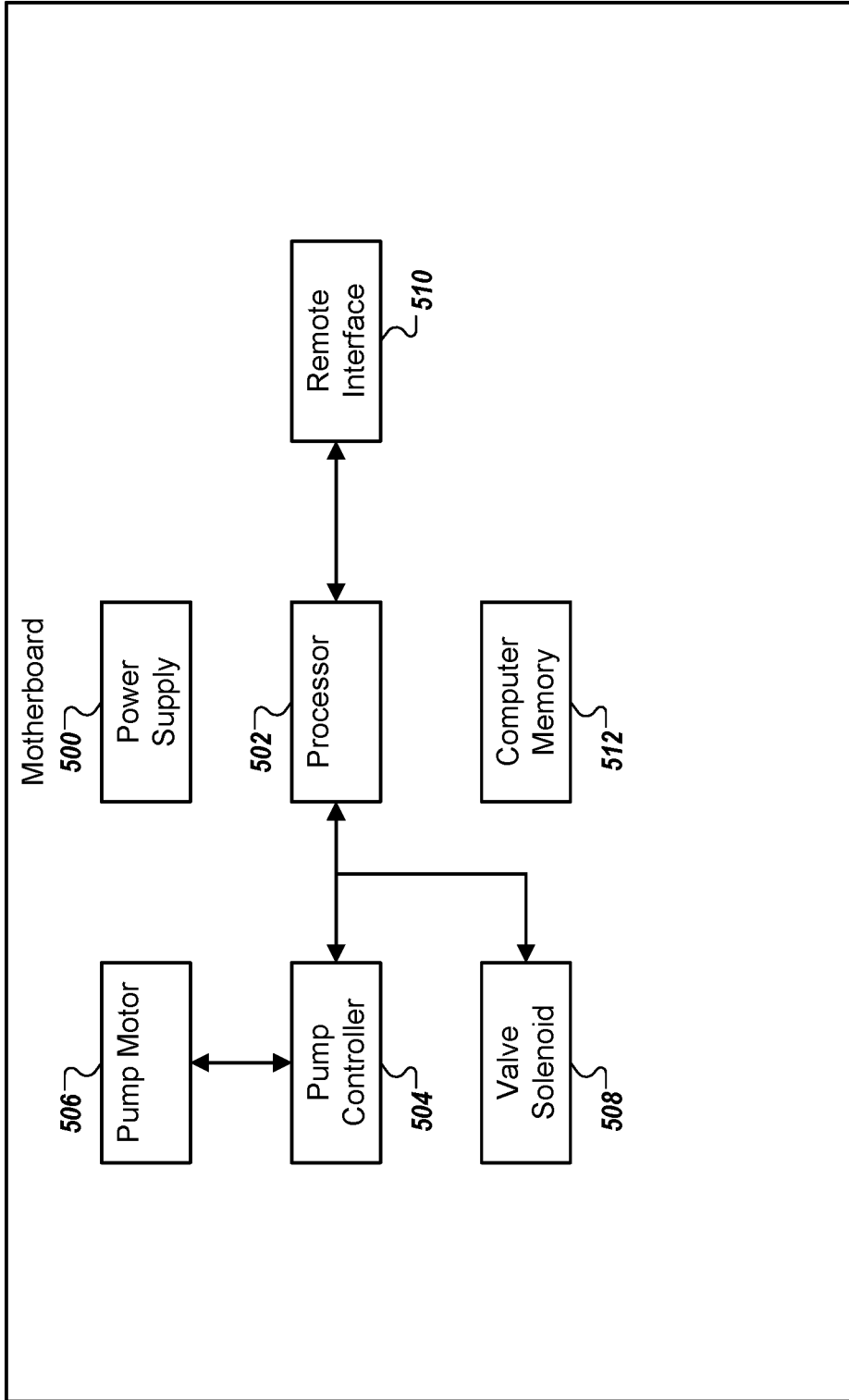

FIG. 4B





402 ↗

FIG. 5



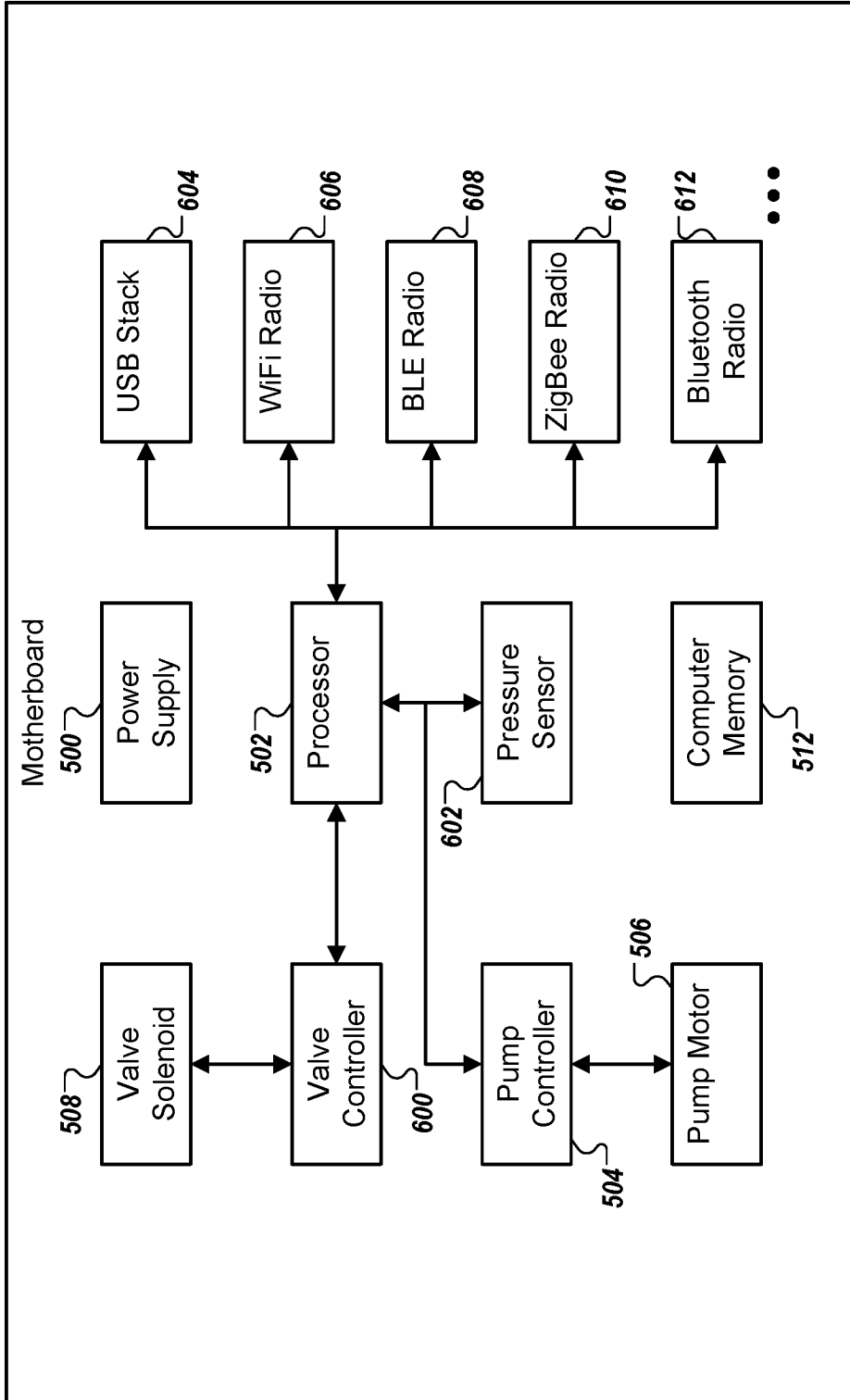
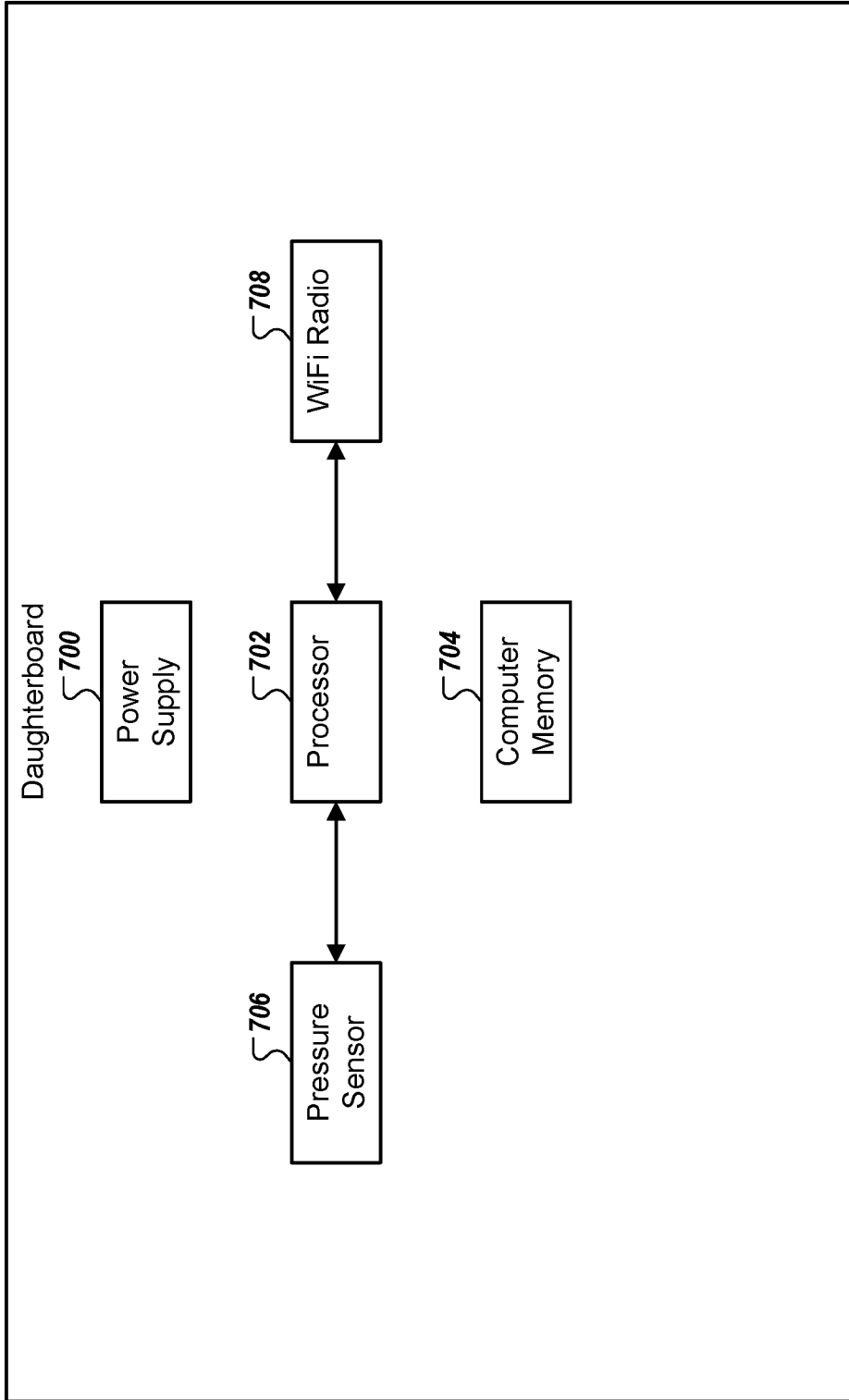

FIG. 6

402 ↗

+



404 ↷

FIG. 7



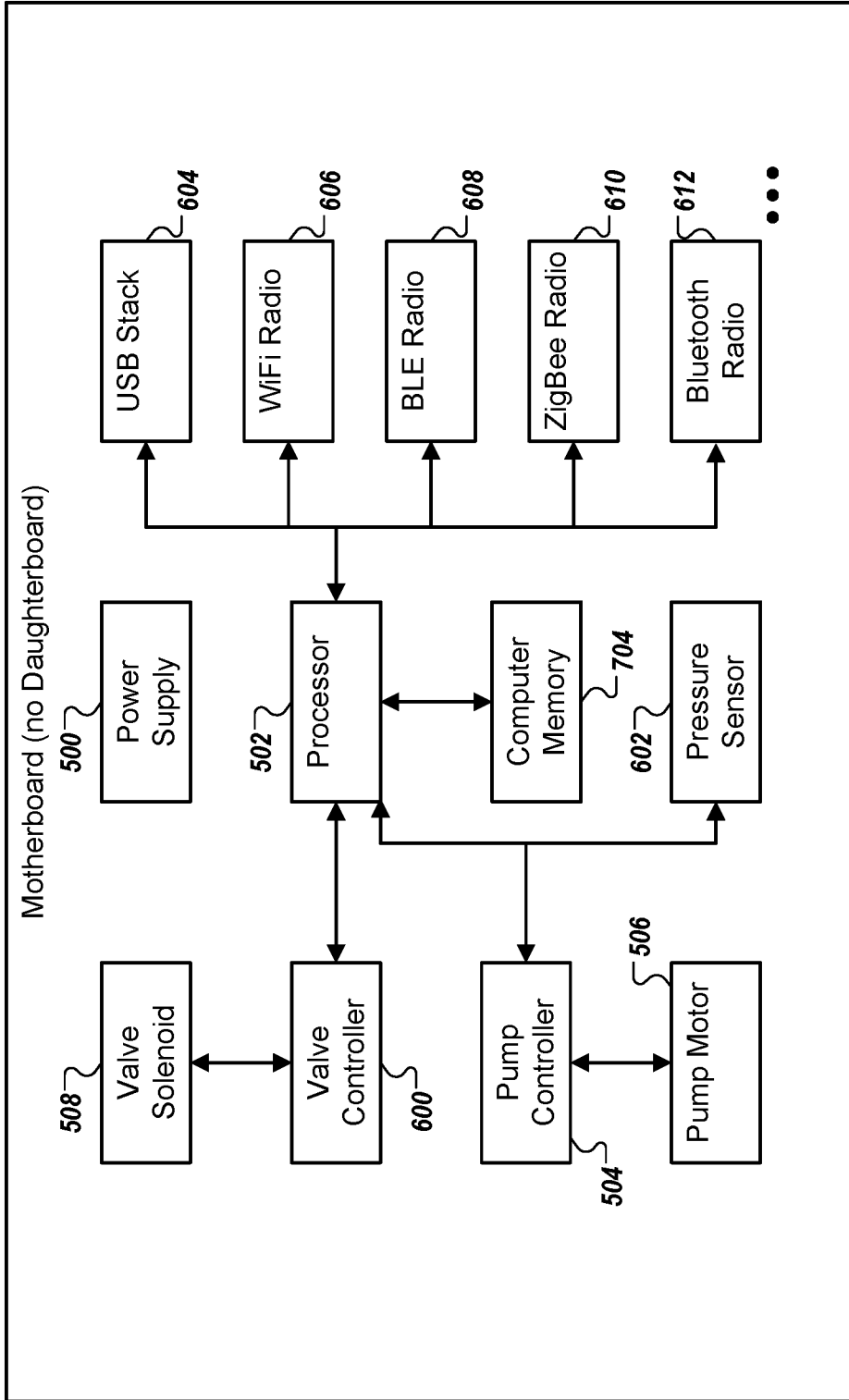

FIG. 8

800 ↗



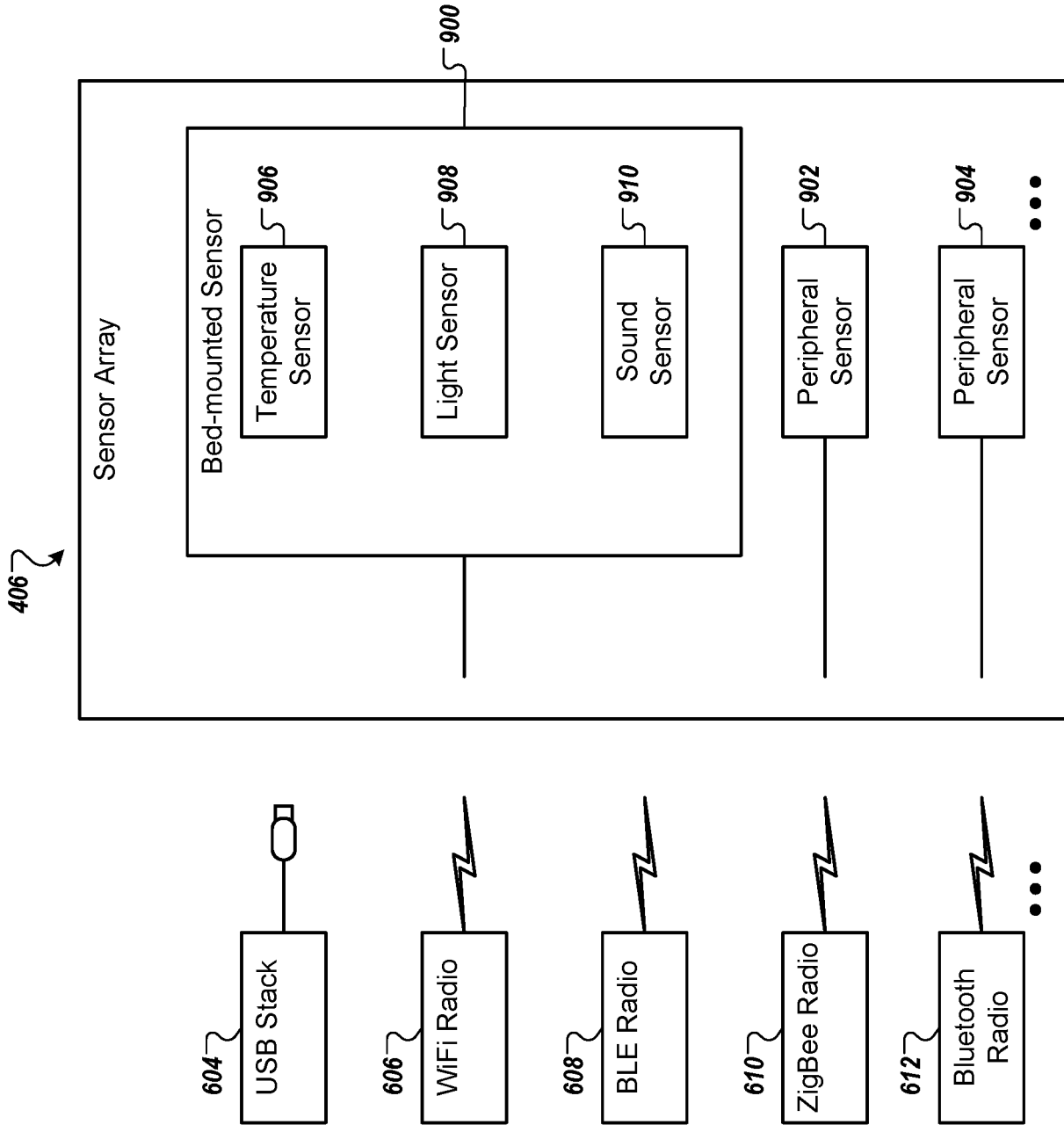

FIG. 9



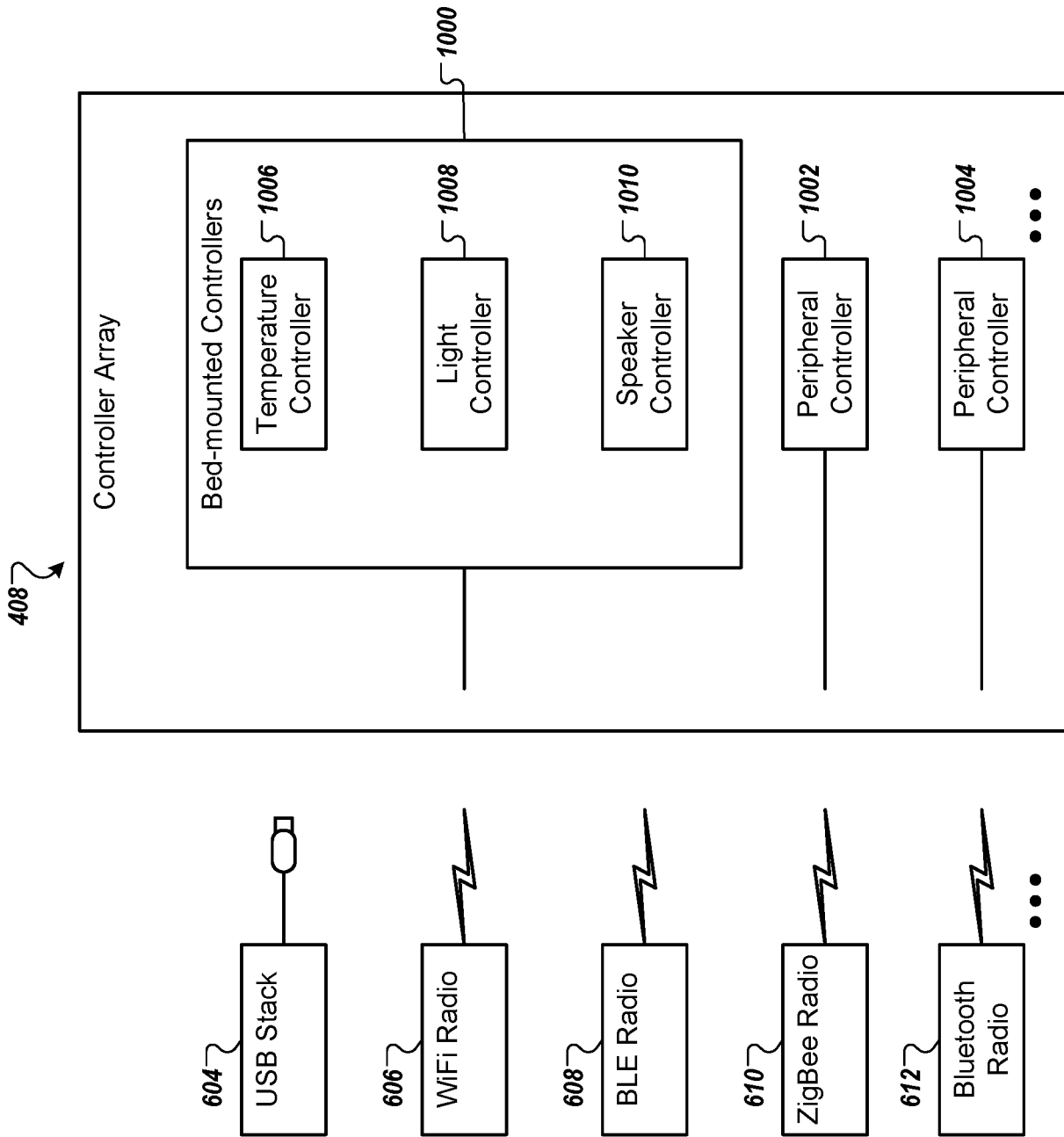

FIG. 10



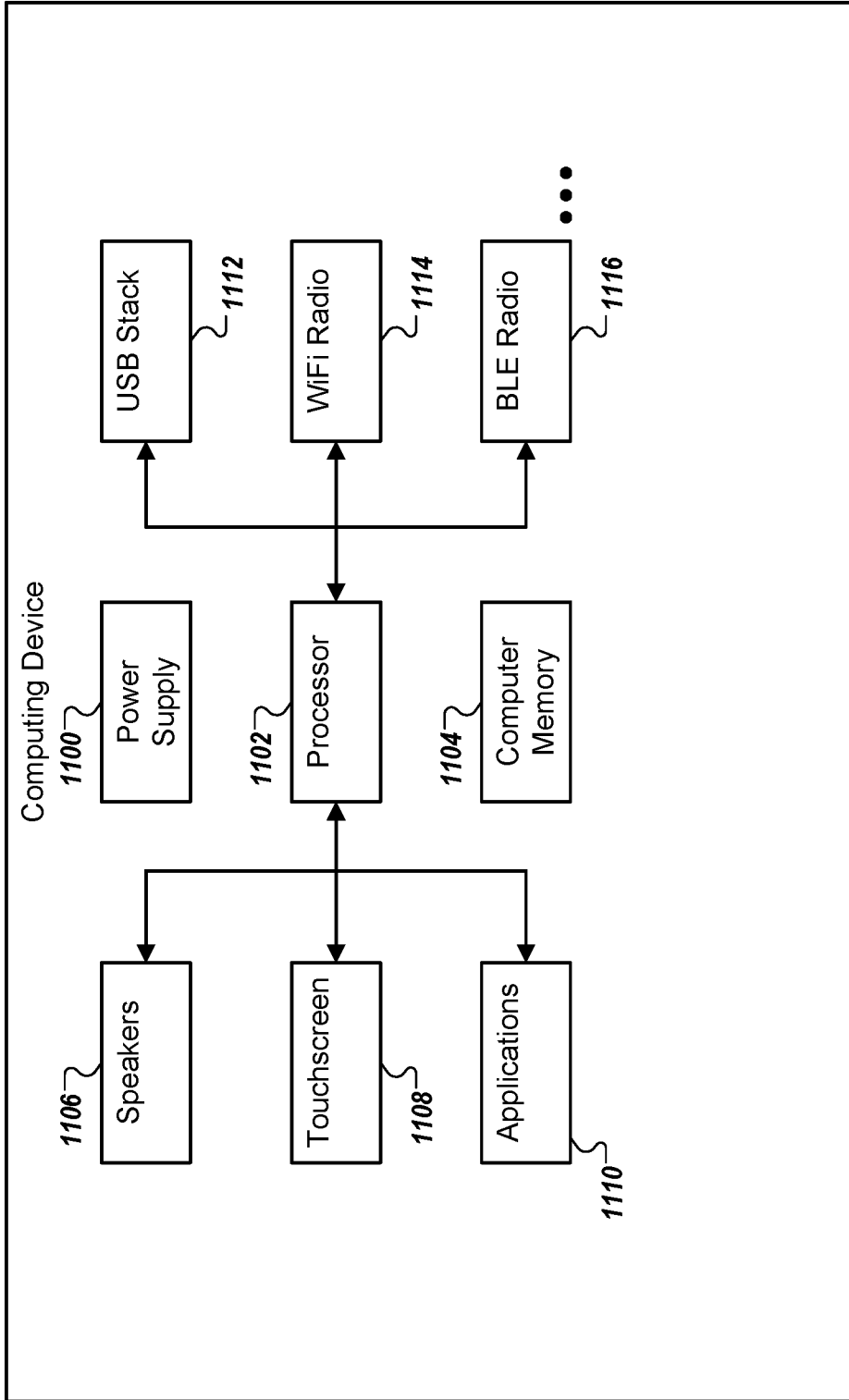

FIG. 11





410a ↷

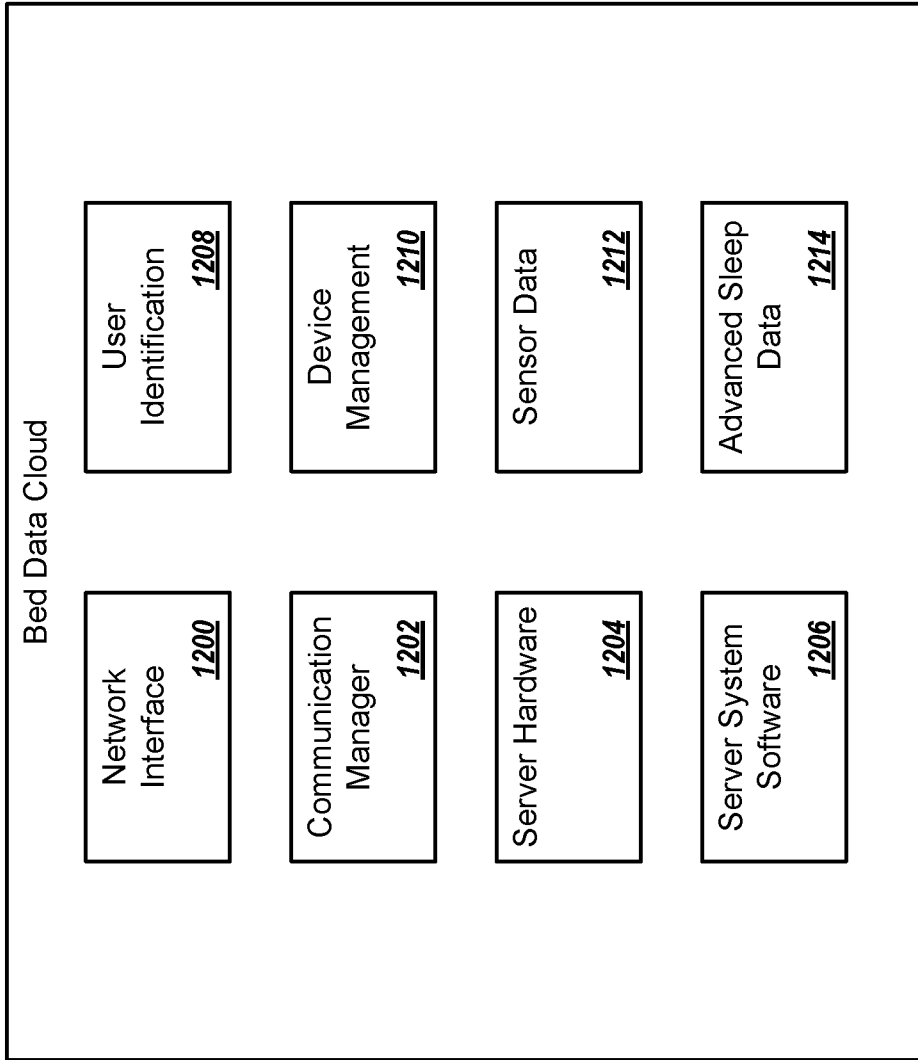
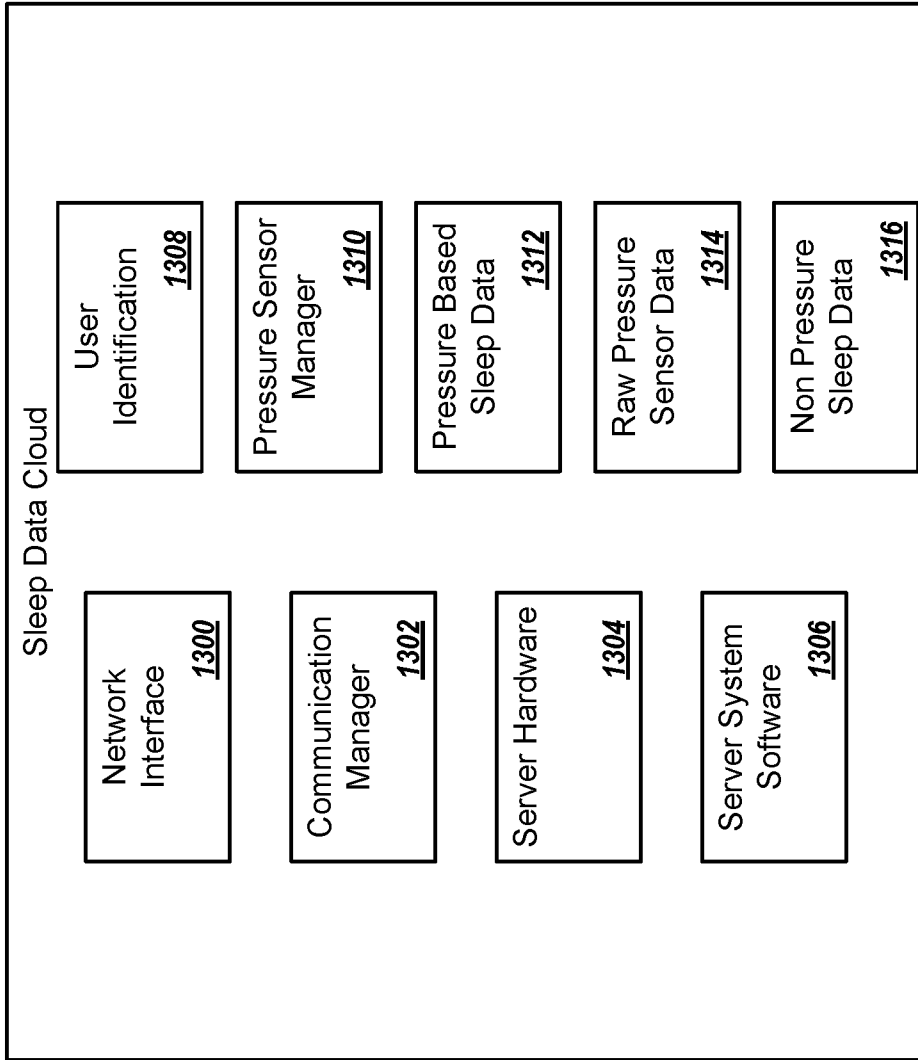

FIG. 12





410b ↷

FIG. 13



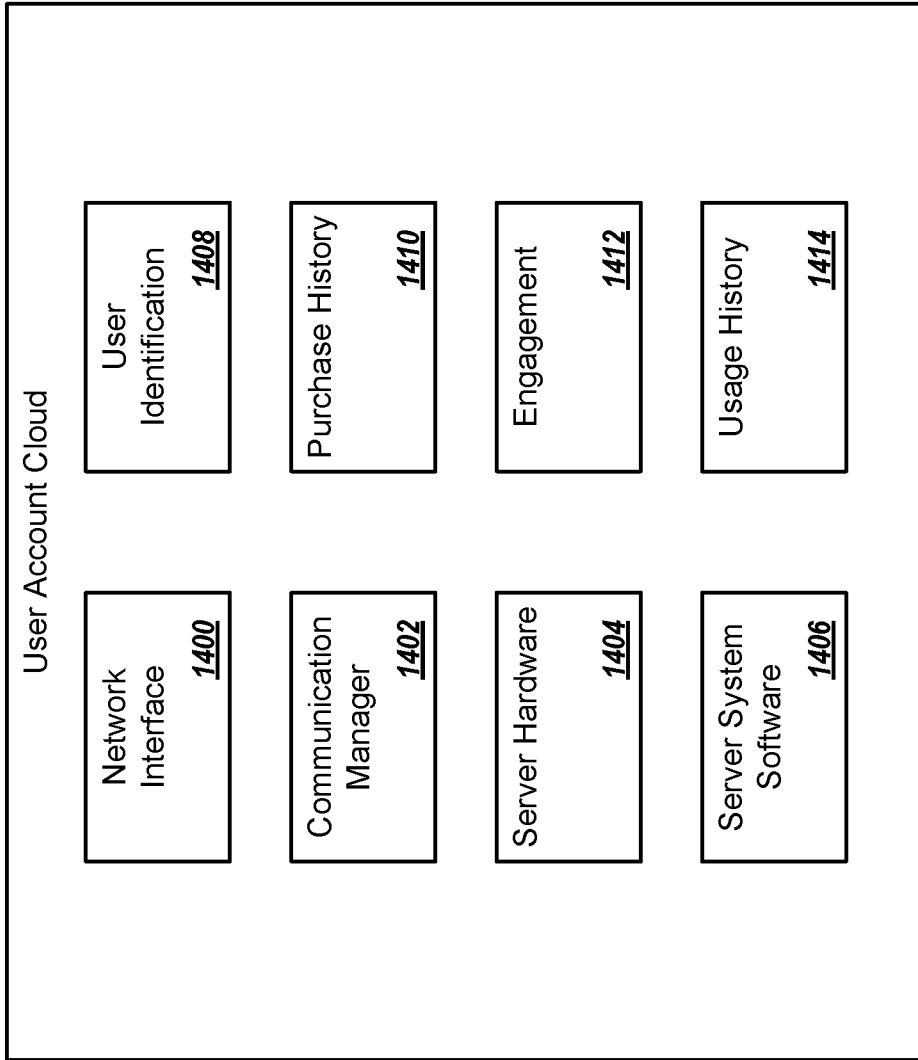

410c ↷

FIG. 14





1500 ↷

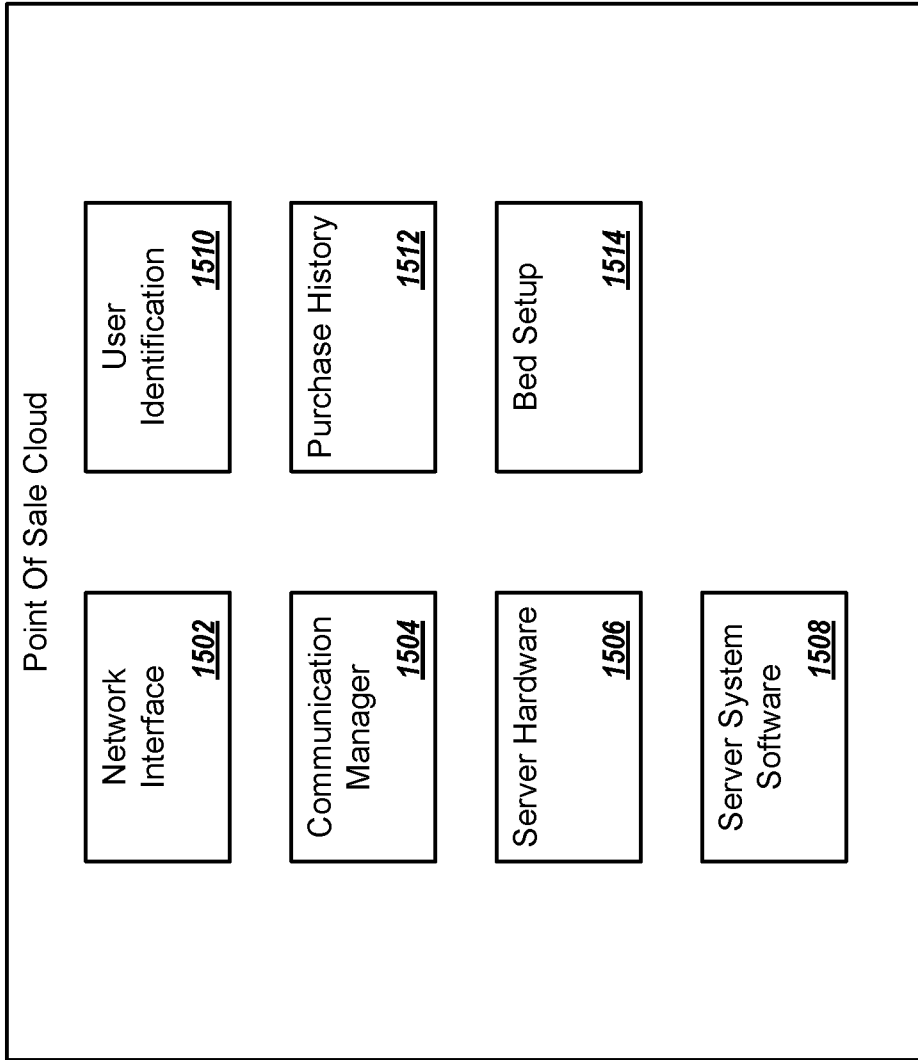

FIG. 15





1600 ↷

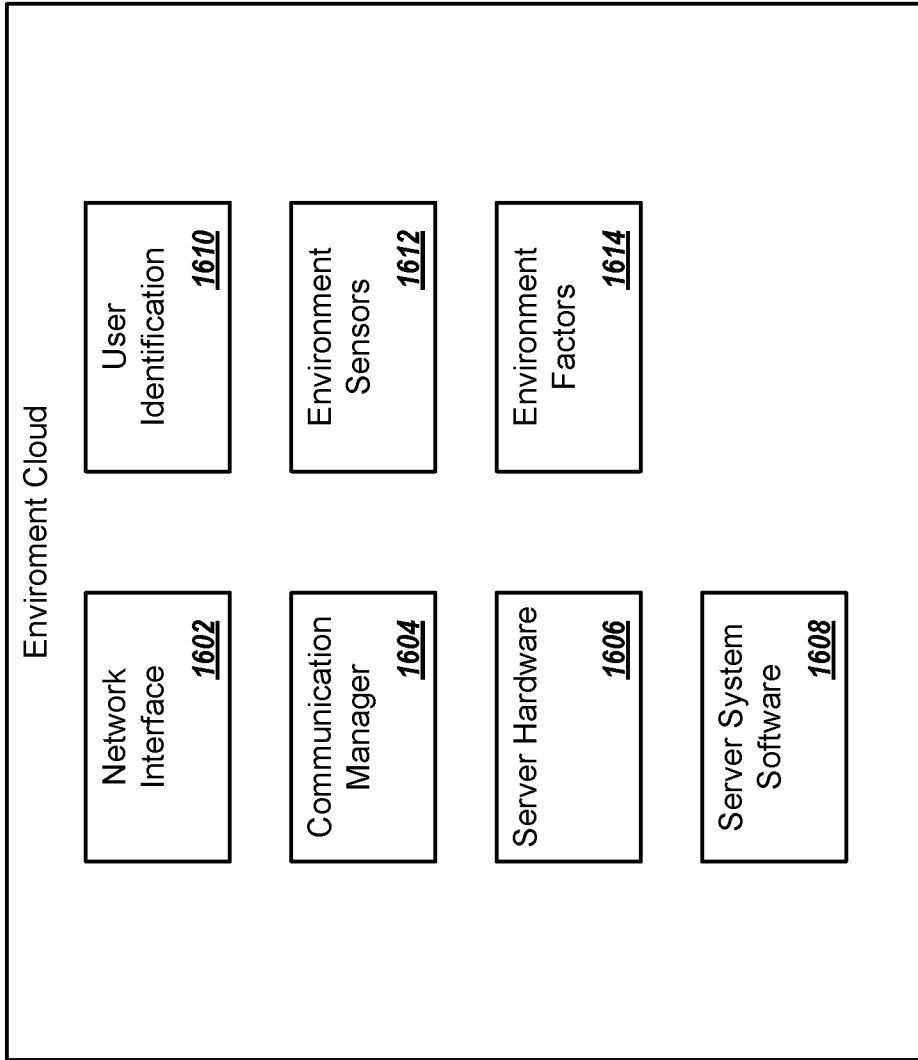

FIG. 16



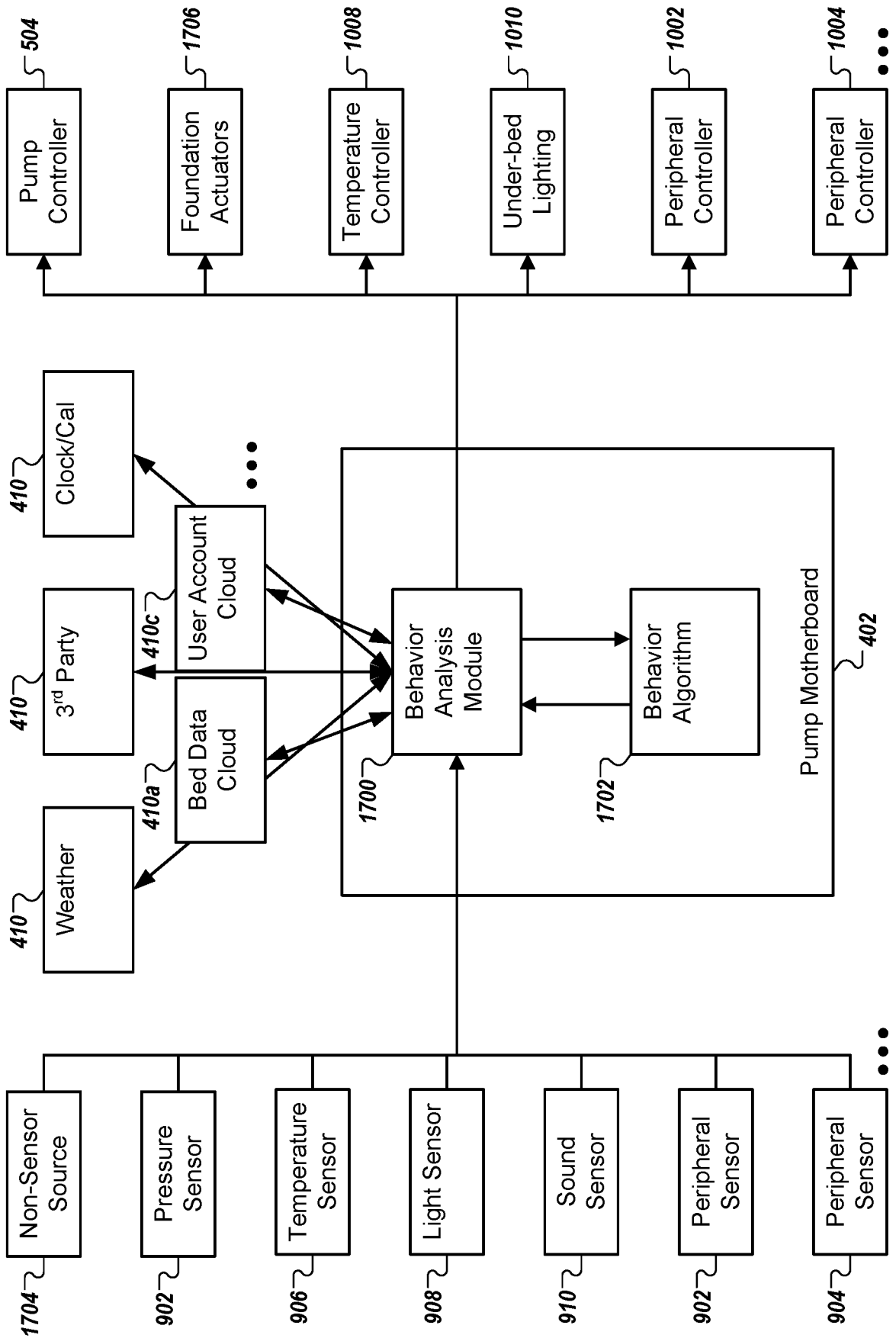

FIG. 17



1900 ↗

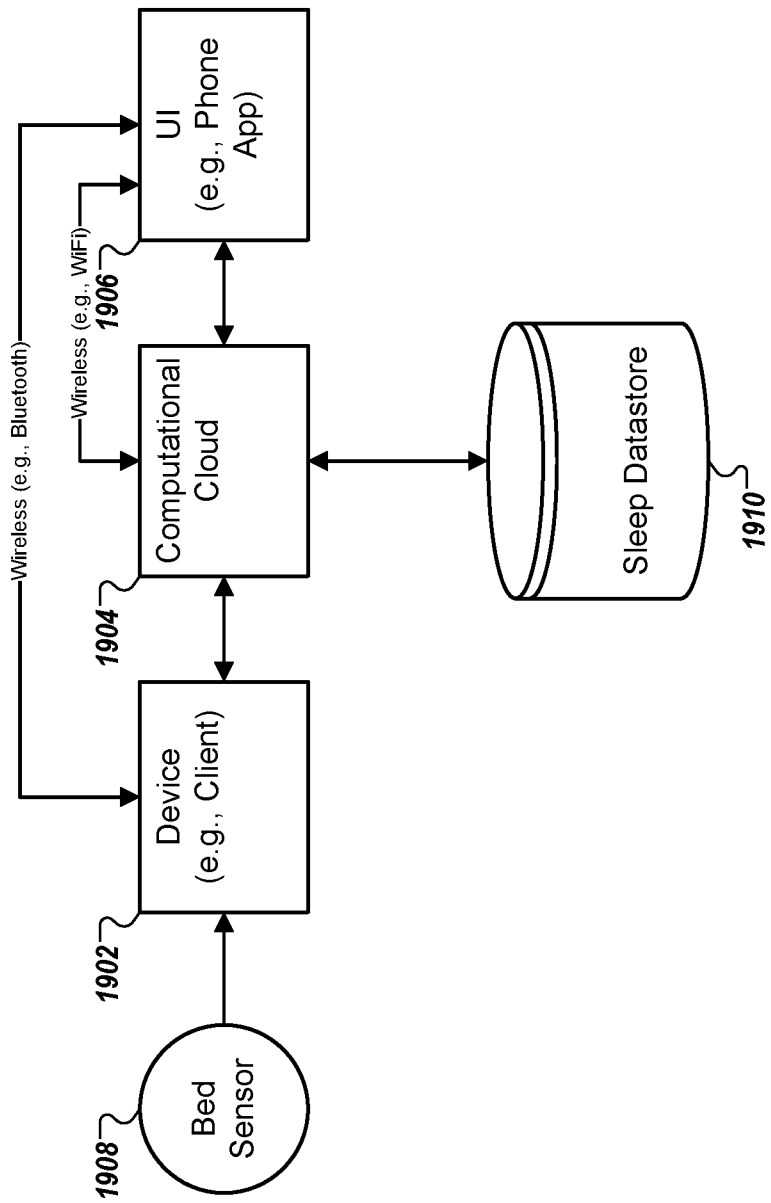

FIG. 19

+

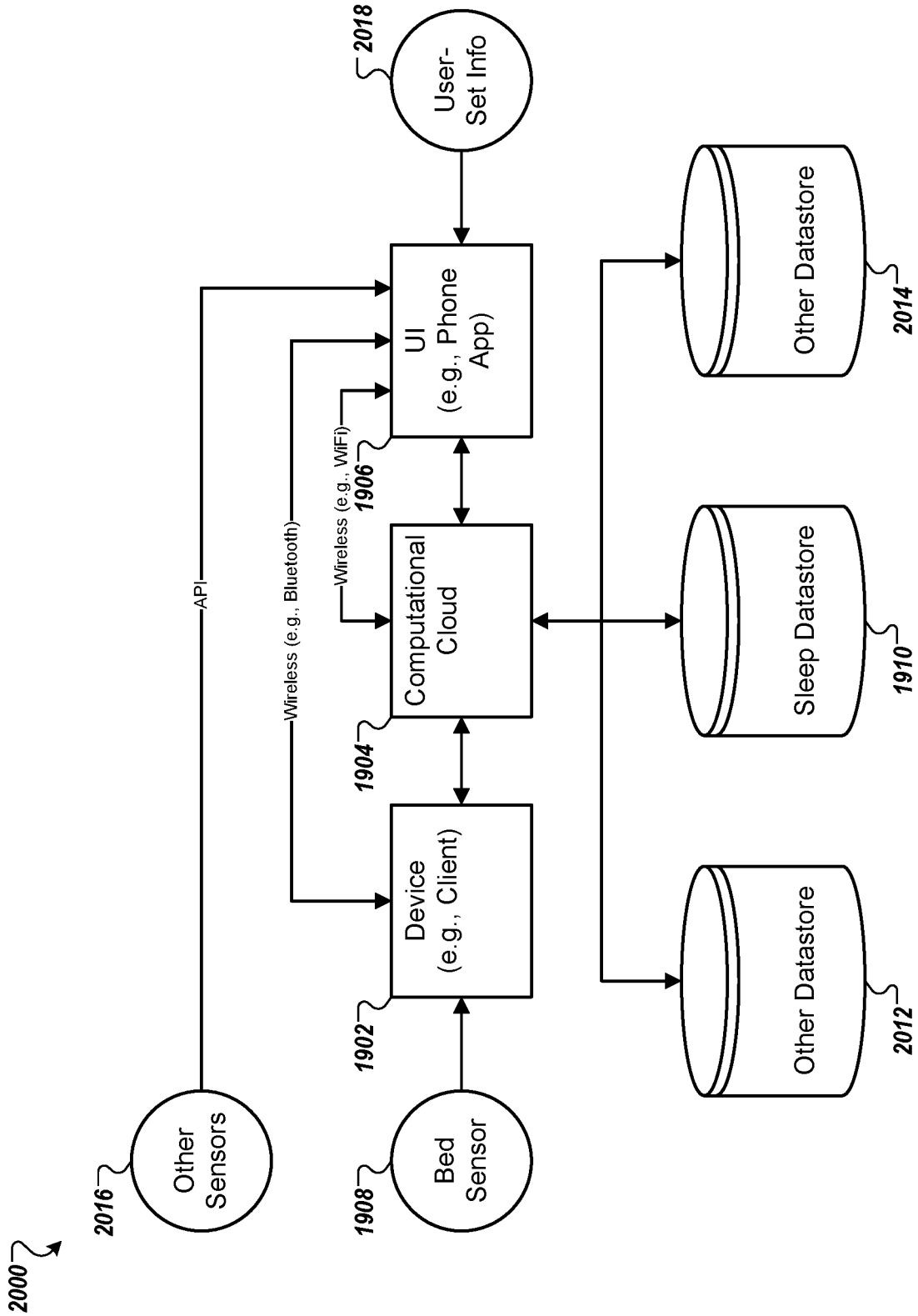

FIG. 20



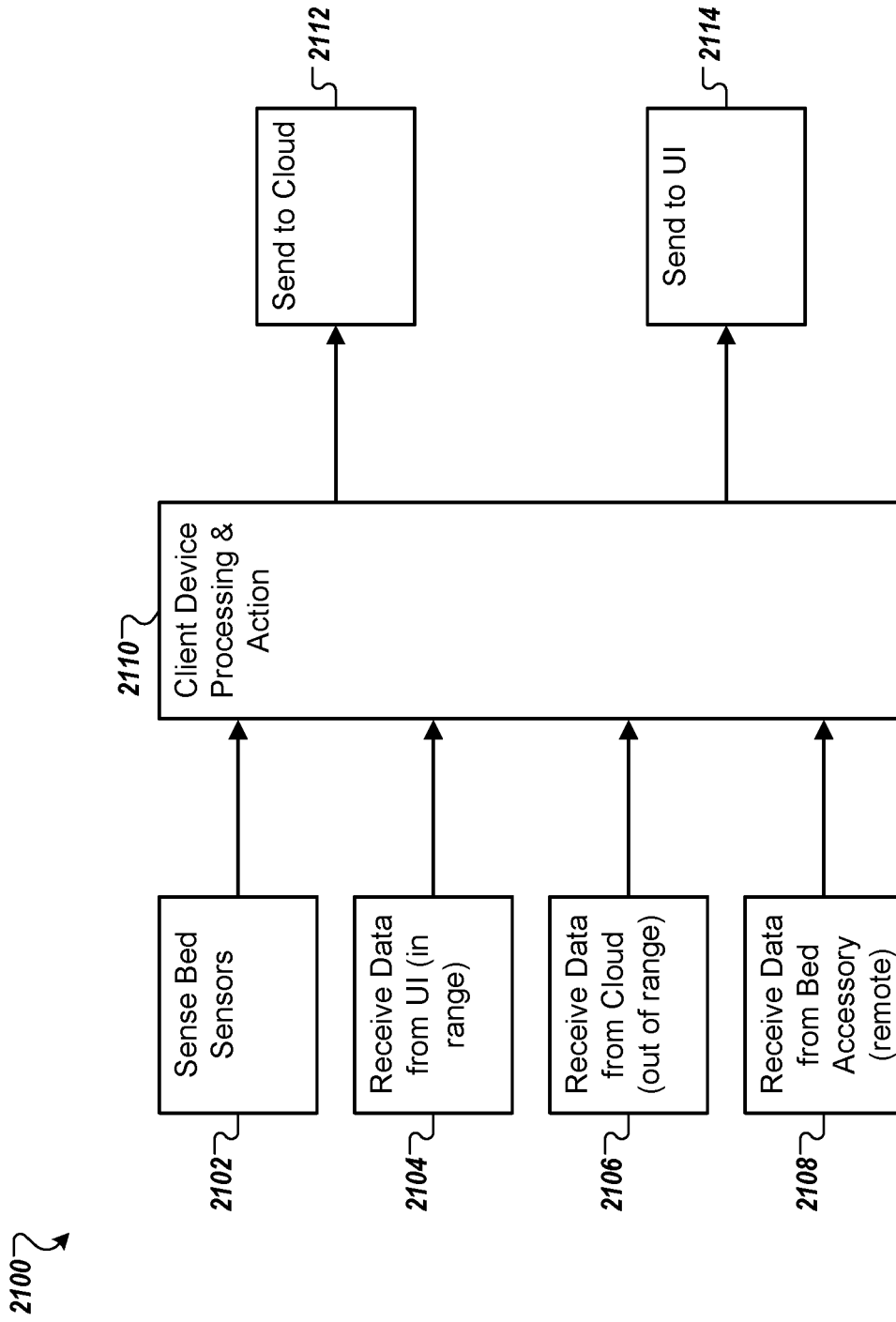

FIG. 21





23/30

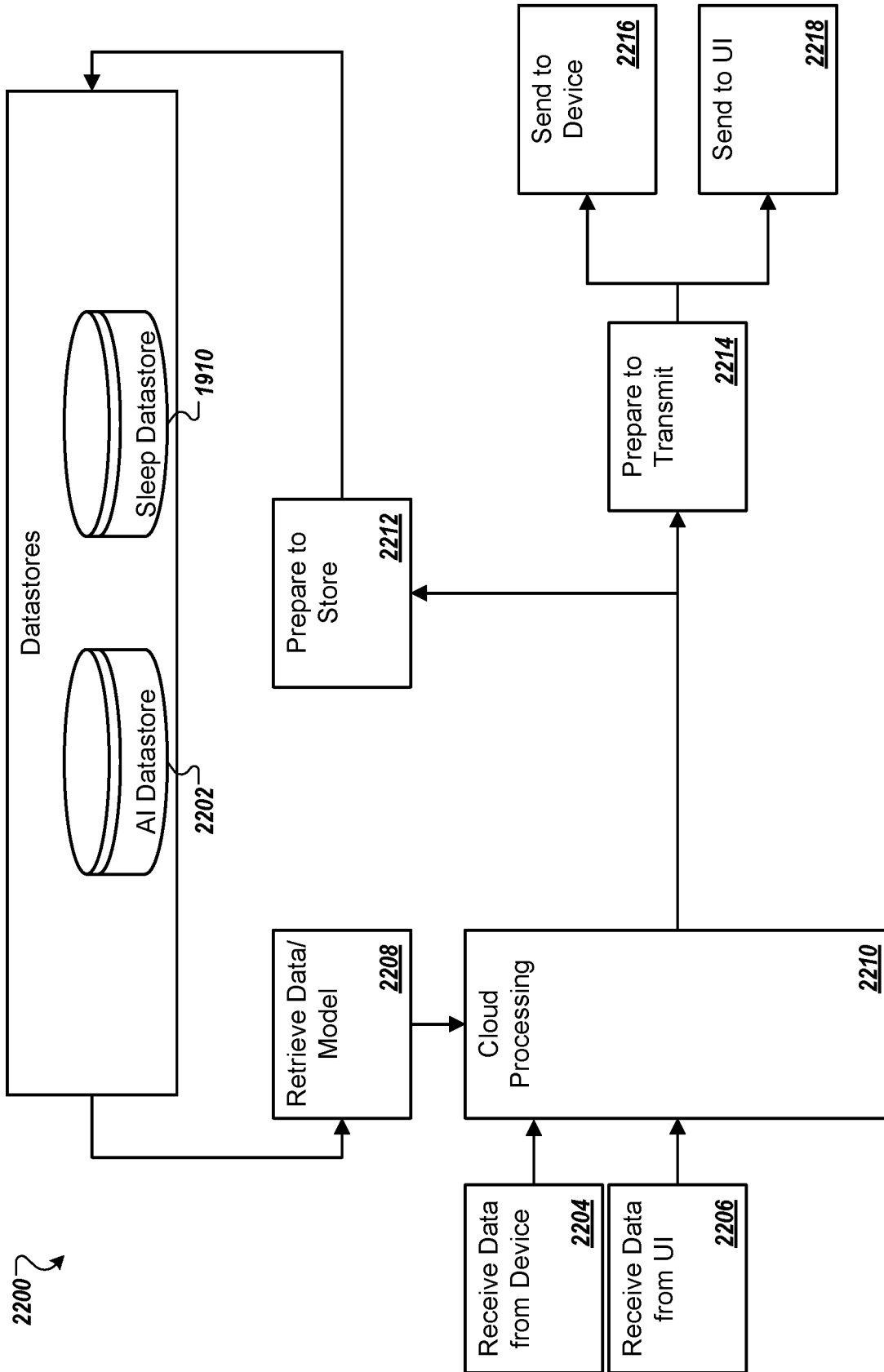

FIG. 22



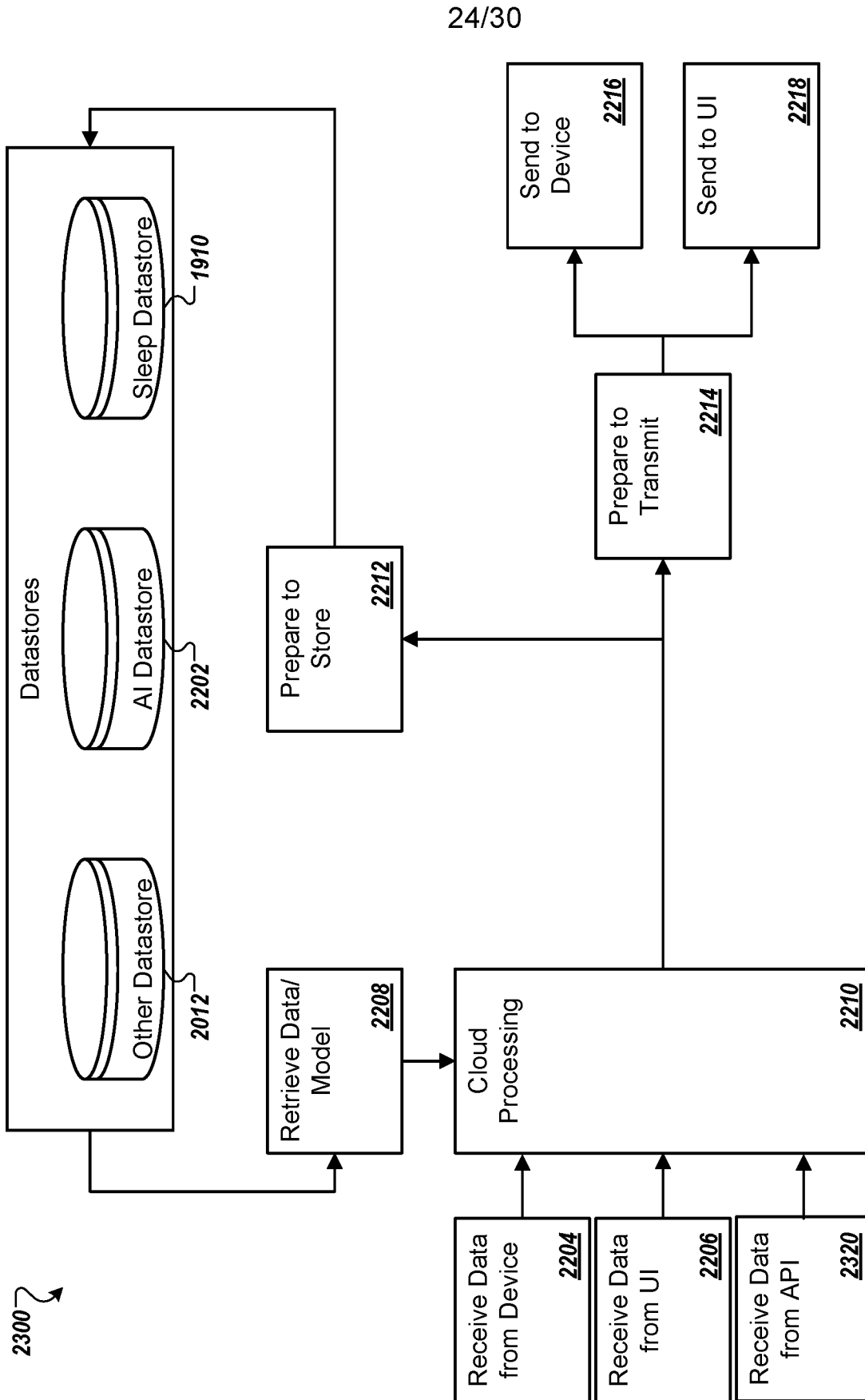

FIG. 23





2400 ↷

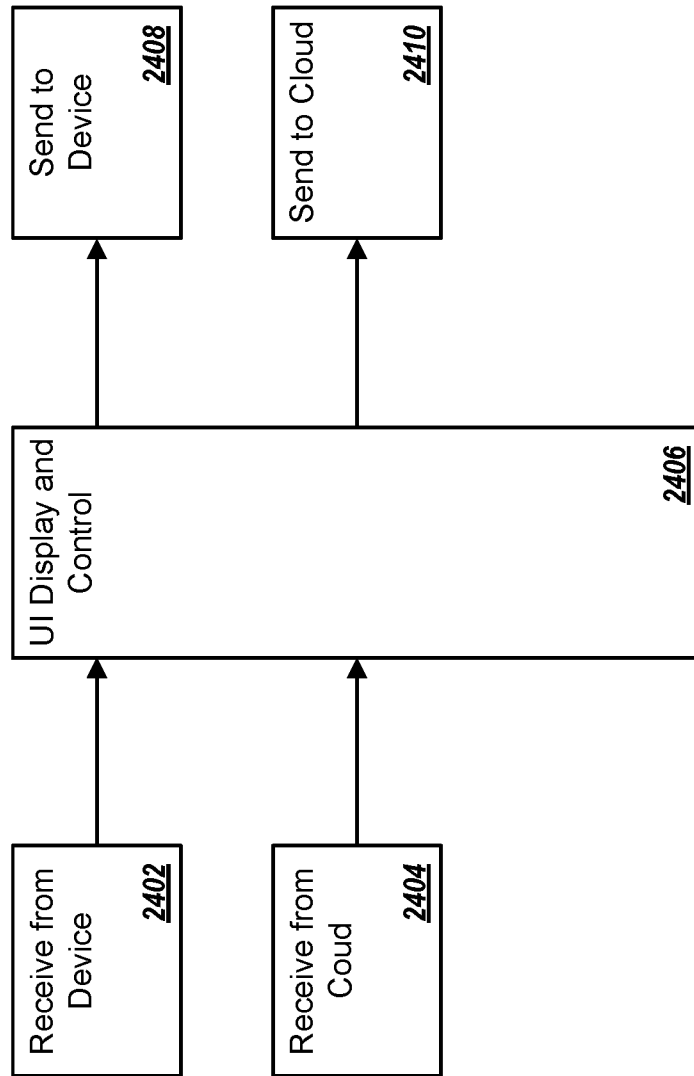

FIG. 24





2500 ↷

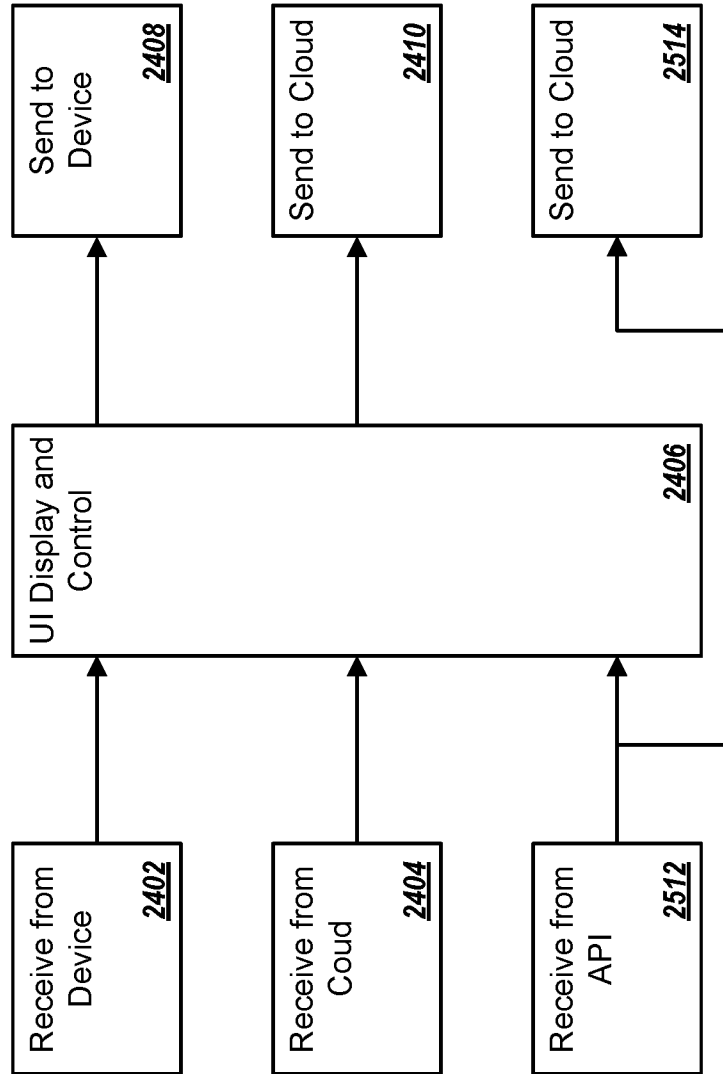

FIG. 25



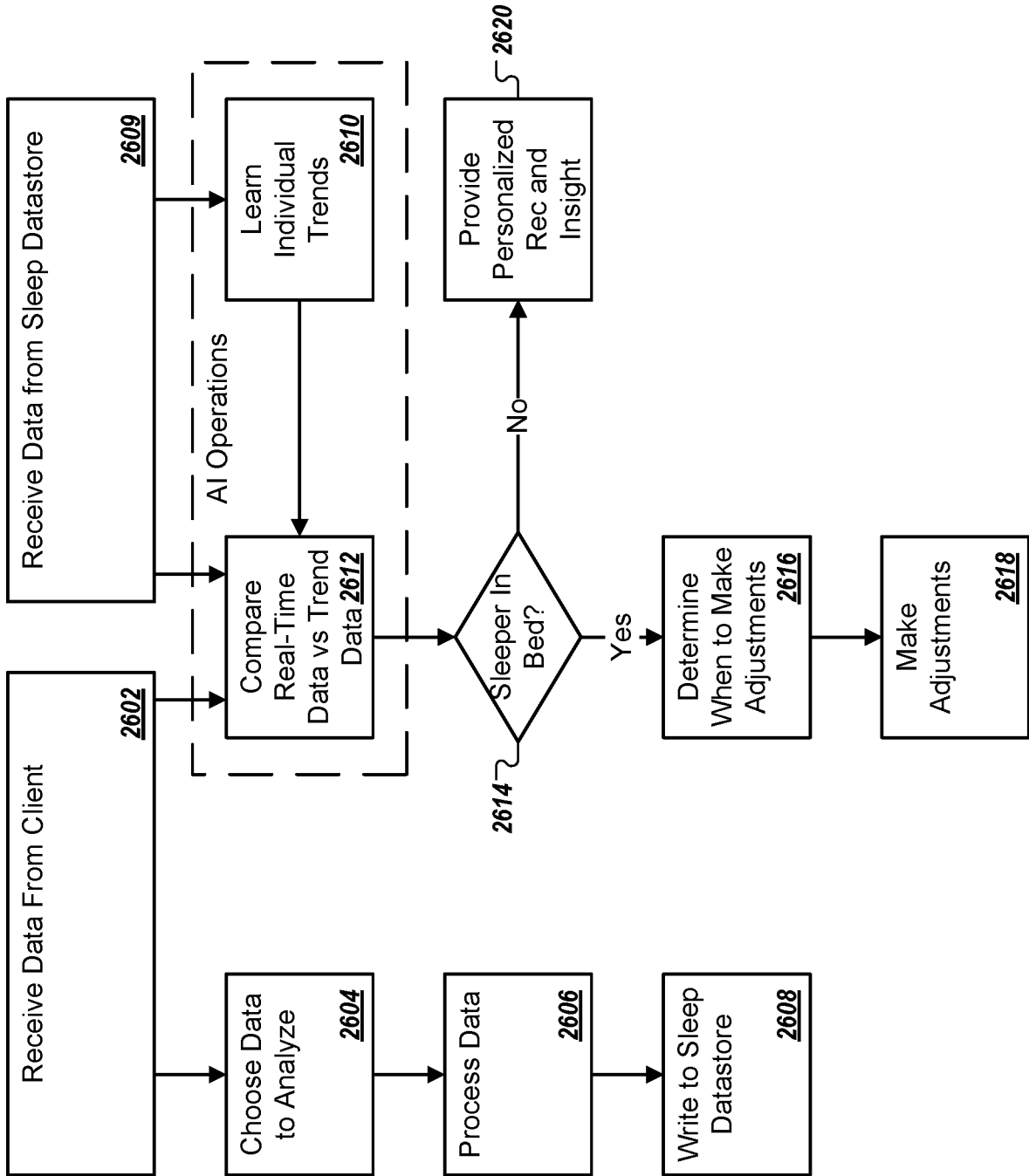

FIG. 26

2600 ↷



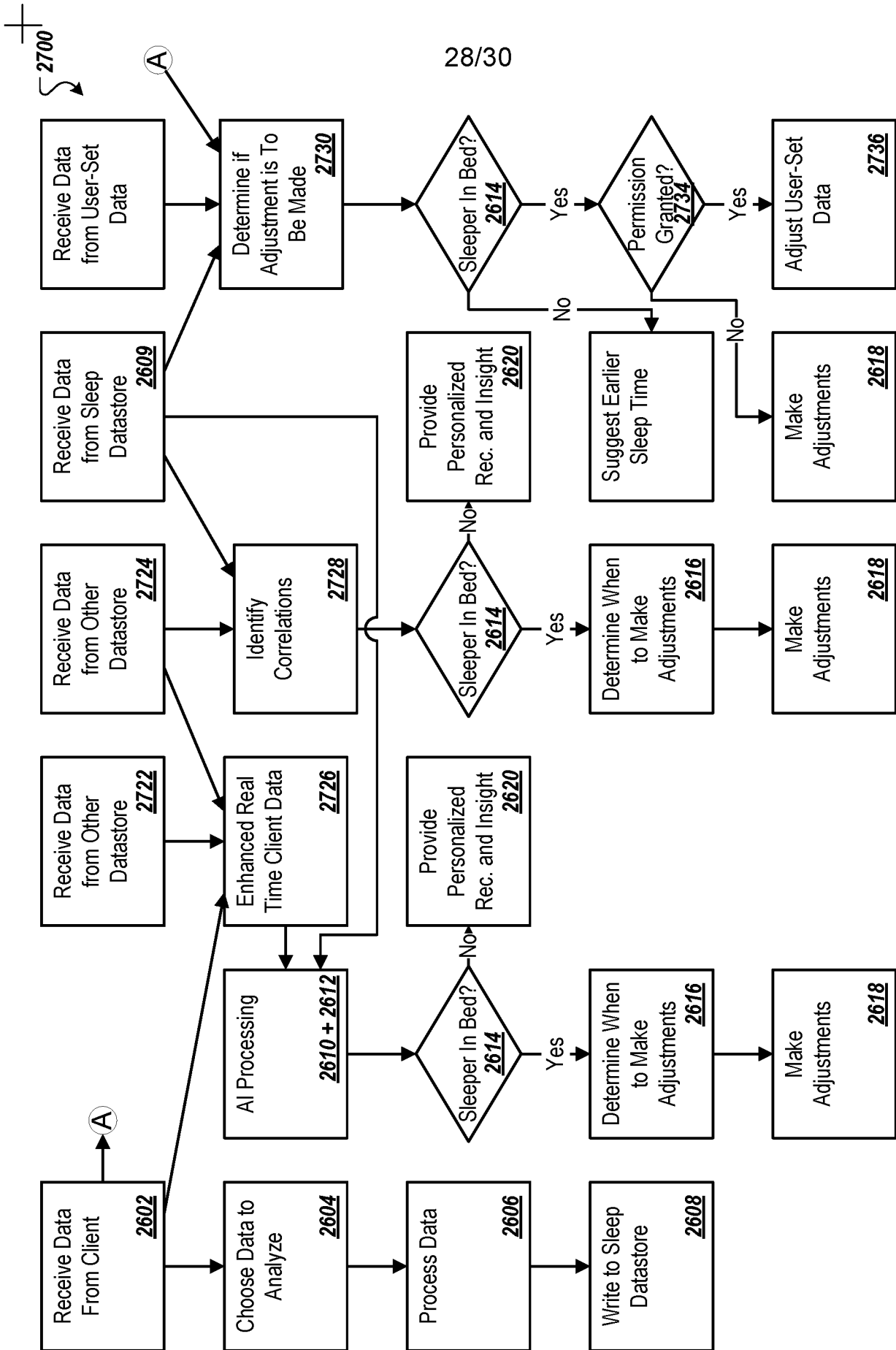

FIG. 27



2800 ↷

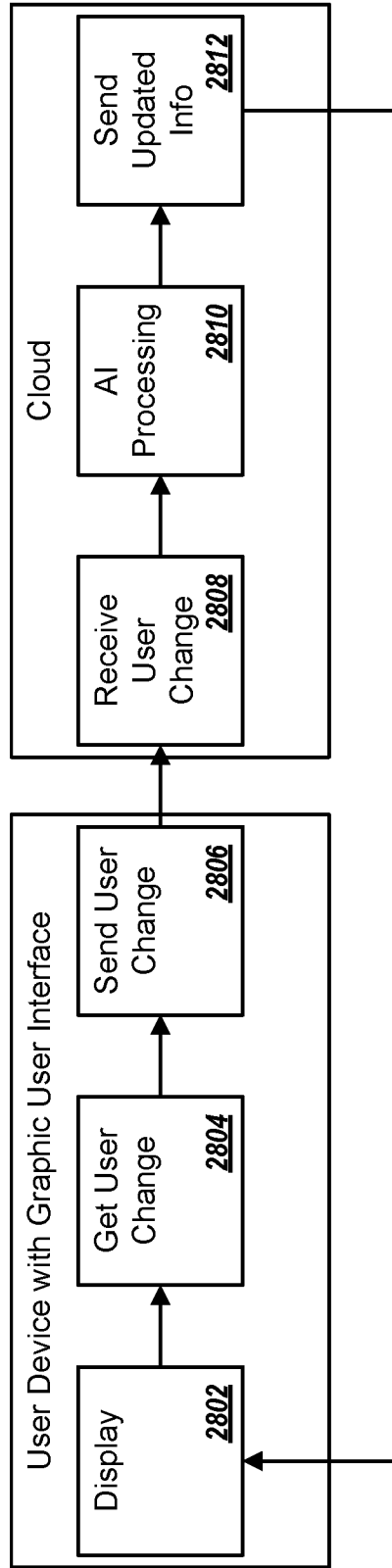

FIG. 28

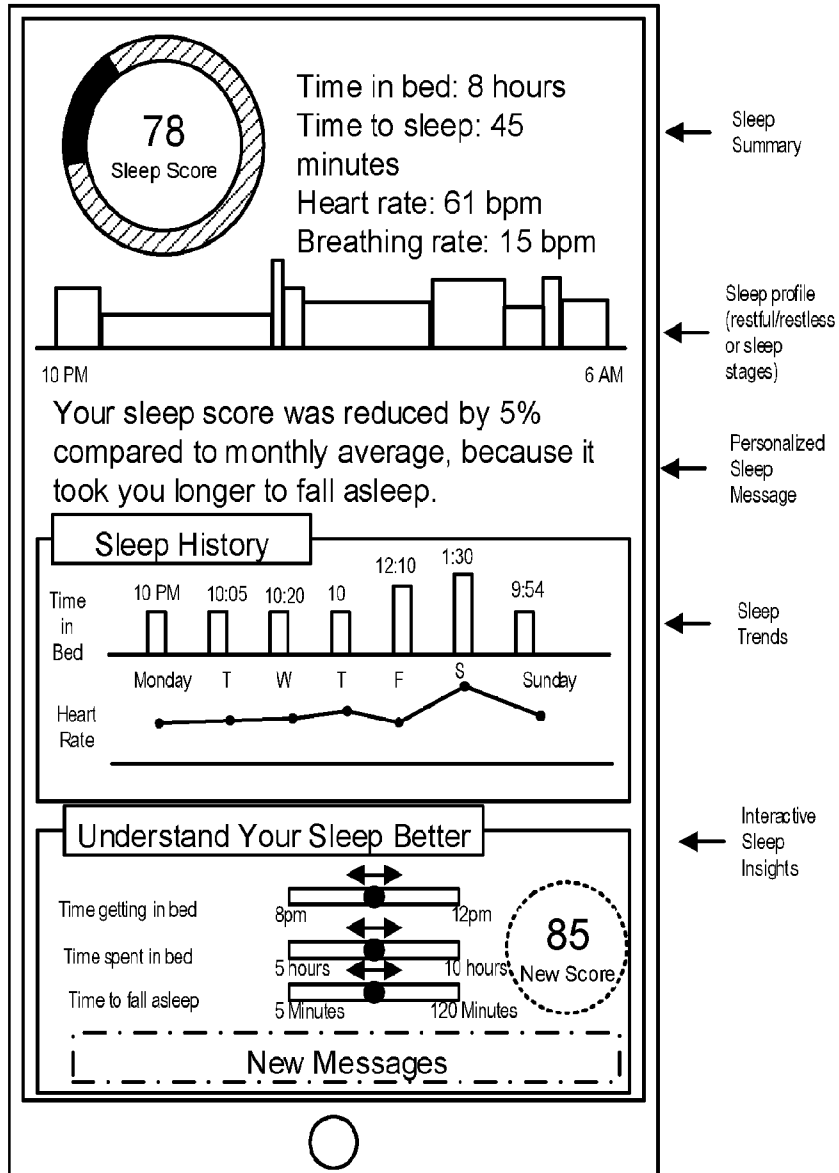

FIG. 29



1900

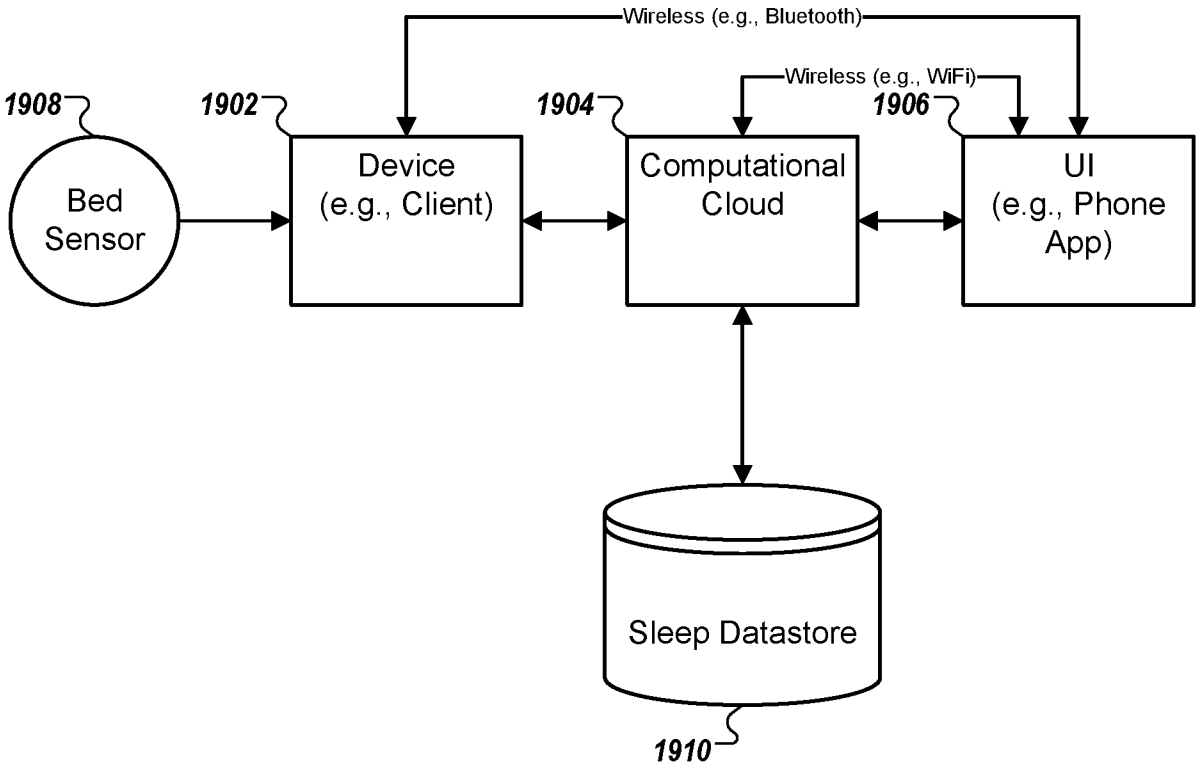

FIG. 19