



US 20040172781A1

(19) **United States**

(12) **Patent Application Publication**

Nakagawa et al.

(10) **Pub. No.: US 2004/0172781 A1**

(43) **Pub. Date: Sep. 9, 2004**

(54) **ELECTRONIC TOOTHBRUSH AND ELECTRONIC BRUSH**

(30) **Foreign Application Priority Data**

Jul. 17, 2000 (JP) 2000-215332

(76) Inventors: **Yoshinori Nakagawa**, Nara-ken (JP);
Takahiro Ikejiri, Osaka (JP)

Publication Classification

Correspondence Address:
FULBRIGHT & JAWORSKI, LLP
666 FIFTH AVE
NEW YORK, NY 10103-3198 (US)

(51) **Int. Cl.⁷** **A46B 9/04**
(52) **U.S. Cl.** **15/105; 15/167.1; 604/20**

(21) Appl. No.: **10/773,760**

(57) **ABSTRACT**

(22) Filed: **Feb. 6, 2004**

An electronic toothbrush comprising: a brush head portion having a bristle portion, to be inserted into an oral cavity, for washing teeth; and a holder portion to be exposed outside the oral cavity, wherein TiO_2 which is an n-type semiconductor is provided so as to receive external light; and the n-type semiconductor is connected to a negative pole of a solar battery and an electrical potential is superimposed on the n-type semiconductor.

Related U.S. Application Data

(63) Continuation-in-part of application No. 09/738,007, filed on Dec. 15, 2000, now abandoned.

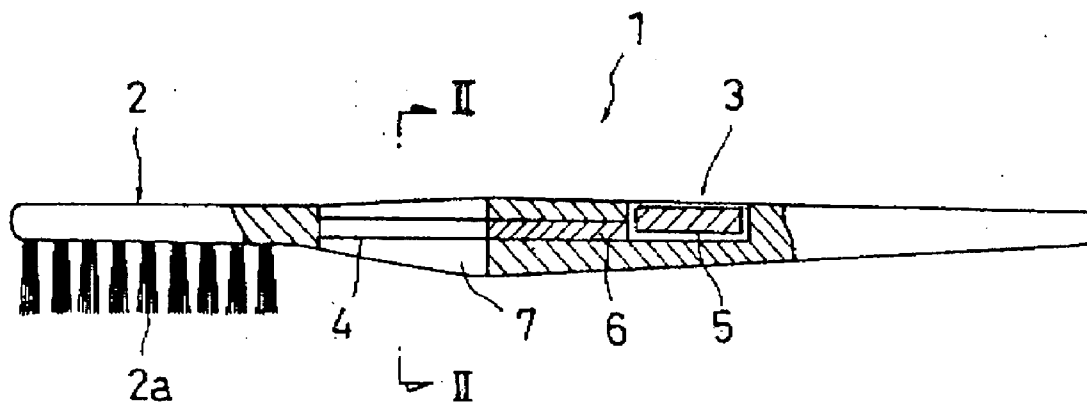

FIG. 1

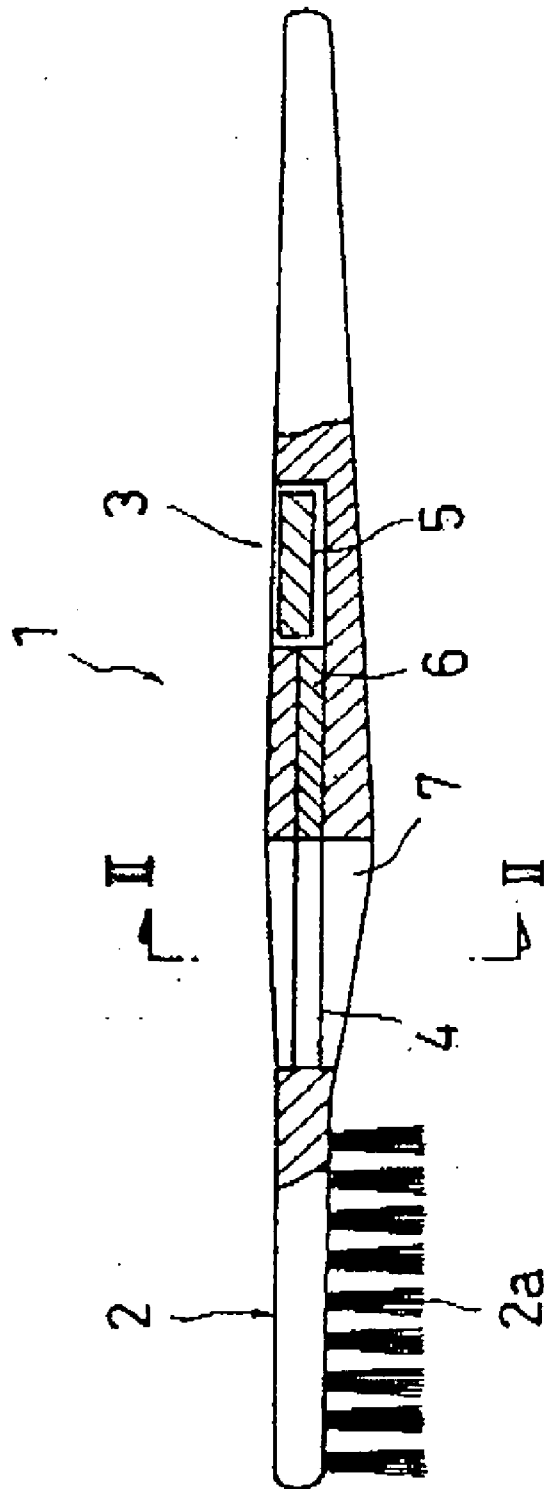

FIG. 2

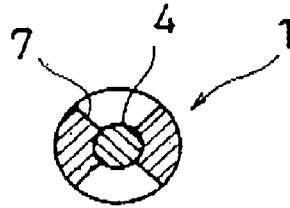

FIG. 7

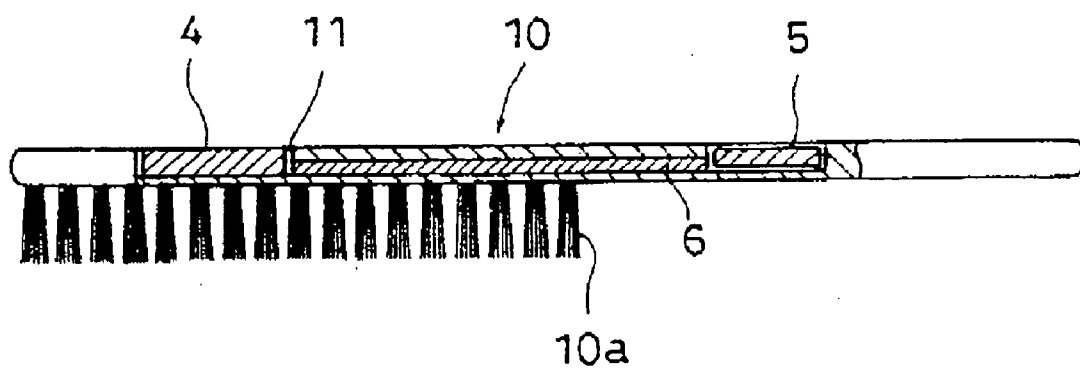
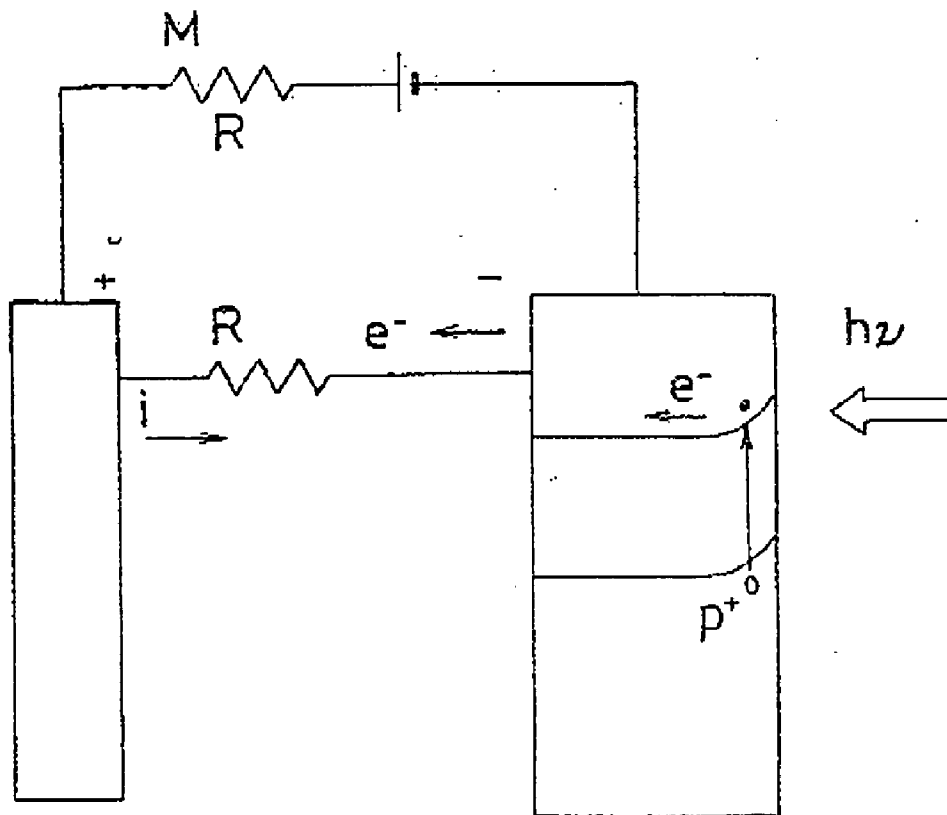

FIG. 3



Counter electrode

N-type semiconductor

FIG. 4

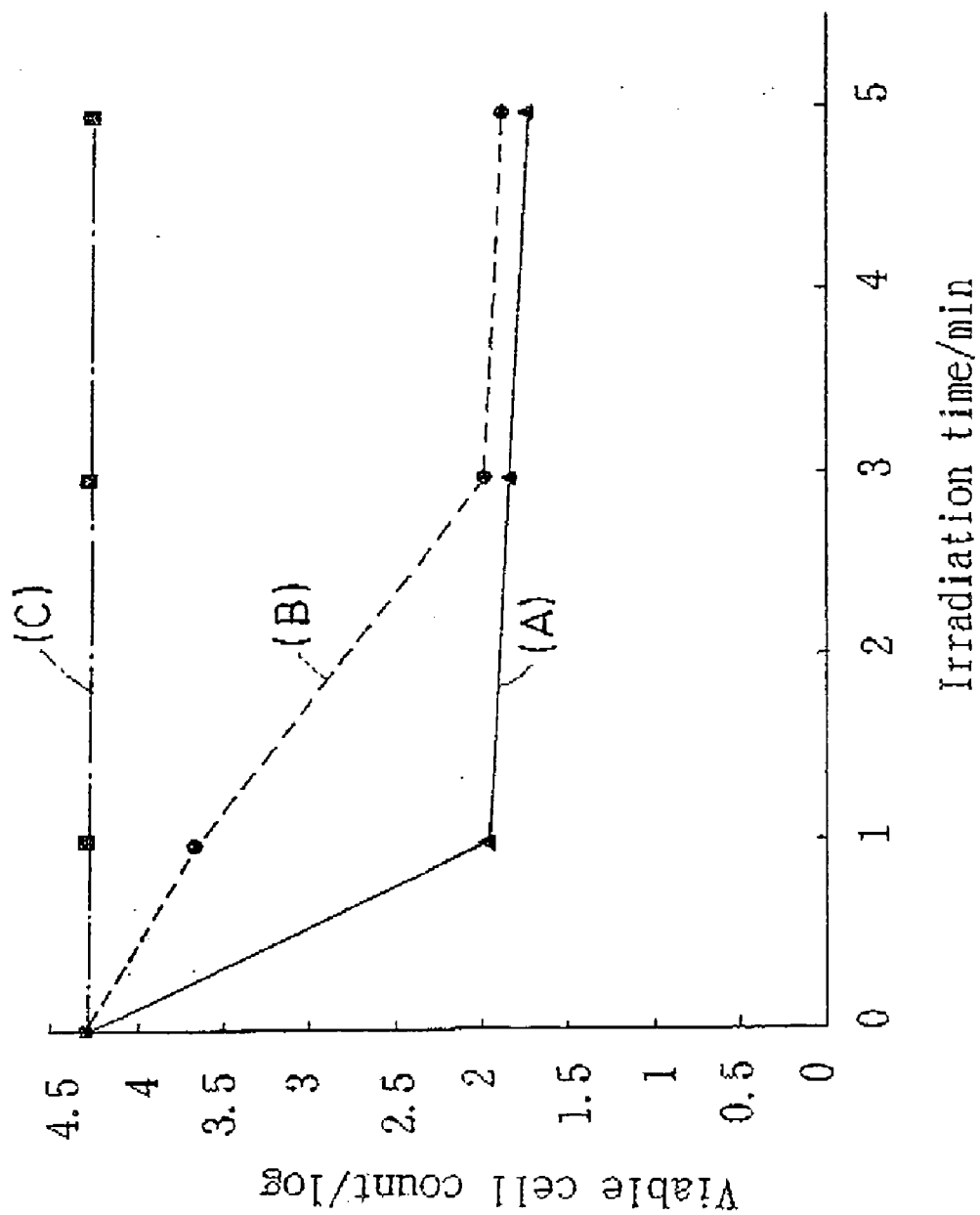

FIG. 5

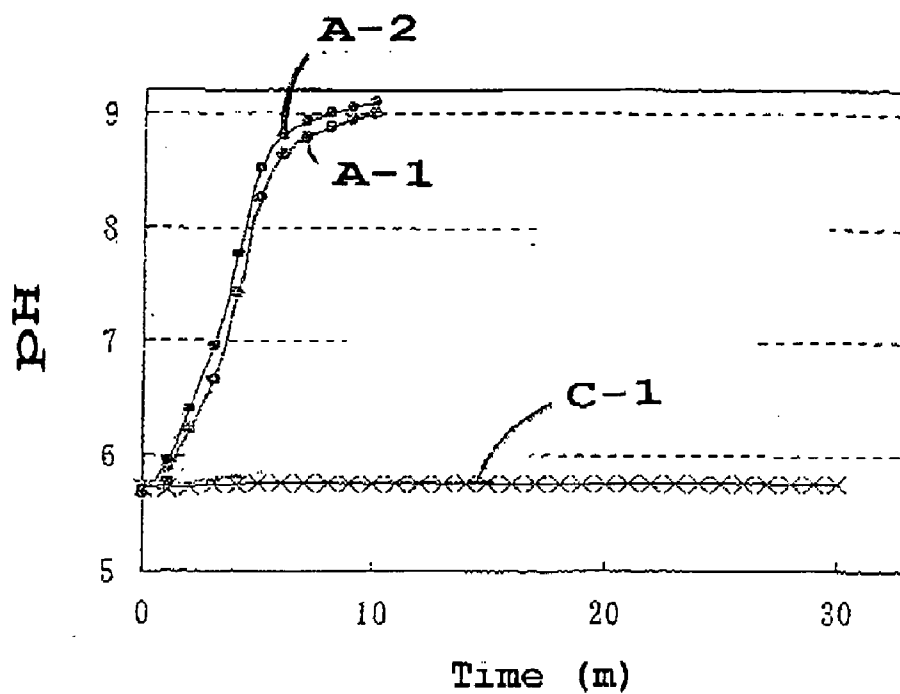
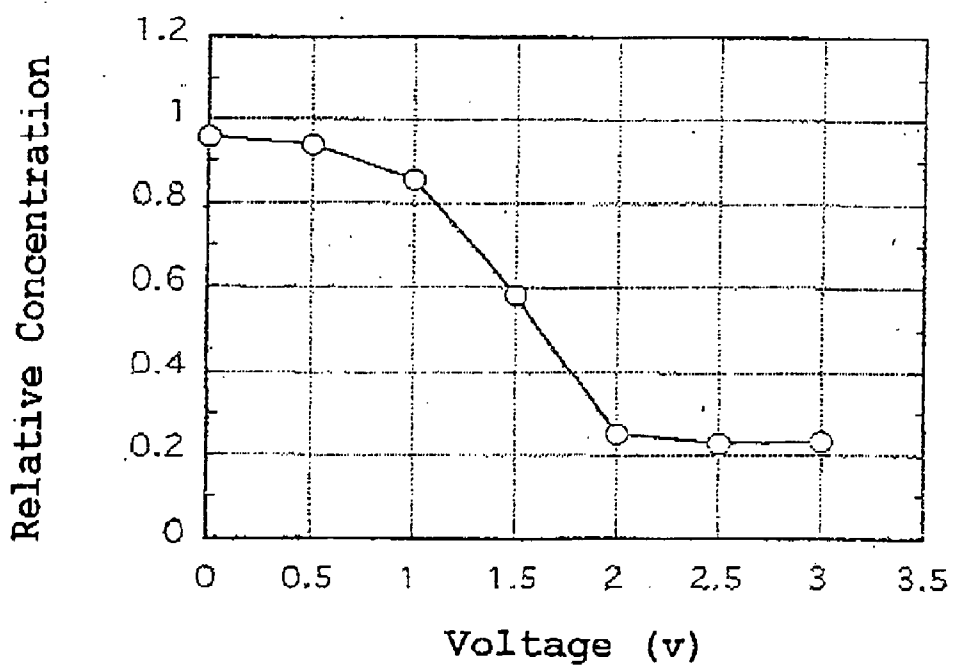

FIG. 6



ELECTRONIC TOOTHBRUSH AND ELECTRONIC BRUSH

BACKGROUND OF THE INVENTION

[0001] 1. Field of the Invention

[0002] The present invention relates to an electronic toothbrush and an electronic brush, and more specifically to an electronic toothbrush and an electronic brush using a photocatalytic reaction of an n-type semiconductor.

[0003] 2. Description of the Related Art

[0004] As a method for preventing intraoral diseases such as dental caries or alveolar pyorrhea, application of a fluoride on the tooth surface or use of a dentifrice containing a fluoride has been conventionally practiced in order to further improve the prevention effect as compared to simply brushing the tooth surface with a toothbrush bearing a dentifrice adhered thereon. However, questions remains as to the effect of these methods because a fluorine ion is inferior in permeability with respect to pulp tissue, and hence, in order to improve the effect of the fluorine ion, a method has been suggested that permeability of a fluorine ion is improved by increasing an electric potential by the action of an external power supply such as battery, domestic power supply and the like.

[0005] However, also this method is not desirable because it has a problem that metal ions associated with generation of an electric current will flow out because a metal which is a conductor is used for the toothbrush portion, and in addition, the electric current, electromagnetic waves, or electric fields can have detrimental effects on a human body when used for a long time.

[0006] In view of the above, the inventors of the present invention invented an electronic toothbrush utilizing a photocatalytic reaction of TiO_2 which is an n-type semiconductor, which does not cause such a problem (Japanese Unexamined Patent Publication JP-A 58-41549 (SHO-58, 1983). TiO_2 is a compound that generates a photoelectron voltage even under the irradiation condition by relatively weak light, and when inserted into the oral cavity, generates OH radicals from the moisture such as saliva and elevates the pH in the oral cavity to accomplish neutralization, thereby decreasing the activity of etiologic bacteria of dental caries, as well as decomposing dental plaque.

[0007] However, in the case where only the photocatalytic reaction of TiO_2 is used, the method of decreasing the activity of etiologic bacteria of dental caries having high activity in an acidic atmosphere will accomplish a predetermined effect as it is, however it inevitably requires a certain time before it exerts the effect. In other words, the direct reason of generation of dental caries is that lactic acid which is generated at the time when the etiologic bacteria of dental caries ferment saburra attacks hard tissue of a tooth, and there is a problem that the lactic acid is continuously generated until the activity of the etiologic bacteria of dental caries is decreased.

[0008] The inventors of the present invention made a thorough study for enabling effective decomposition of generated lactic acid, and found that effective decomposition of lactic acid can be accomplished by providing an electric potential of more than or equal to a predetermined value at

the time of using the photocatalytic reaction of then-type semiconductor, and that such an effect acts not only on decomposition of the lactic acid but also on decomposition of organic matters.

SUMMARY OF THE INVENTION

[0009] In view of the above problems, it is an object of the invention to provide an electronic toothbrush which, by using a photocatalytic reaction of the n-type semiconductor, not only decreases the activity of etiologic bacteria of dental caries but also improves decomposition of generated lactic acid, thereby preventing dental caries more effectively, and to provide an electronic brush which can wash each part of a body more effectively than the case where washing is conducted simply by using soap water, by decomposing organic waste such as dirt generated at each part of the body.

[0010] The aforementioned object is accomplished by the invention according to each aspect. That is, an electronic toothbrush according to the present invention is featured by comprising:

[0011] a brush head portion having a bristle portion, to be inserted into an oral cavity, for brushing teeth;

[0012] a holder portion to be exposed outside the oral cavity;

[0013] an n-type semiconductor which is formed of TiO_2 and receives external light; and

[0014] a battery which is a solar battery having an output of more than 0.5 V and less than 3.0V, connected only to the n-type semiconductor such that the n-type semiconductor is connected to a negative pole of the solar battery, and superimposes an electrical potential on the n-type semiconductor in order to synergistically enhance a photocatalytic effect of the n-type semiconductor.

[0015] According to the present configuration, owing to the photocatalytic action of the n-type semiconductor, in the case where the toothbrush is inserted into an oral cavity, in addition to the fact that OH radicals generated by decomposition of moisture such as saliva increase the pH within the oral cavity to neutralize the same, thereby decreasing the activity of etiologic bacteria of dental caries, the OH radicals reliably and rapidly decompose lactic acid generated by lactic fermentation of foods by bacteria, so that dental caries can be prevented from occurring. In other words, in contrast to the case where only the photocatalytic action of n-type semiconductor effected by external light is employed (e.g. fluorescent lamp in a washroom), by superimposing the electric potential of the battery, an energy level required for decomposing lactic acid and water can be achieved, so that the photocatalytic effect of the n-type semiconductor can be improved synergistically. As a consequence, it is possible to improve the efficiency of generation of OH radical while reliably improving the pH by toothbrushing operation. Additionally, in the case of practically performing toothbrushing operation in a washroom and the like, even under the condition that light irradiation is weak because illumination of lighting equipment such as fluorescent lamp in the washroom is low, since the battery which makes the electric potential of the n-type semiconductor more than or equal to a predetermined value is provided, a desired effect can be stably achieved. As a result, according to the present inven-

tion, there can be provided an electronic toothbrush that can prevent intraoral diseases such as dental caries more effectively.

[0016] Furthermore, since the n-type semiconductor is formed of TiO_2 and the output of the battery is more than 0.5 V and less than 3.0 V, the following effect is brought about.

[0017] Specifically, TiO_2 is effective for improving decomposition of lactic acid or increasing the pH because it exhibits a particularly large photocatalytic effect among n-type semiconductors, and the electrical potential required for causing a photocatalytic action is maintained more than or equal to the predetermined value, and the current flowing into a human body via a hand is kept extremely weak to produce no adverse effect on the human body, which is advantageous. In other words, when the output of the battery is less than or equal to 0.5 V, decomposition of lactic acid is insufficient, whereas when the output of the battery is more than or equal to 3.0 V, although decomposition of lactic acid is promoted, the current flowing into a human body is increased to cause discomfort when the toothbrush is held by a wet hand, and thus such ranges are not preferable. More preferably, the output of the battery is not less than 1.0 V and less than 3.0 V.

[0018] In the case where TiO_2 is issued as the n-type semiconductor, the reaction formula for decomposing lactic acid into water and carbon dioxide by photocatalytic action is as follows:

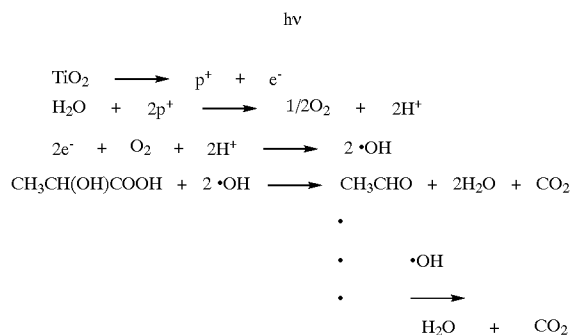

[0019] wherein “p⁺” represents a positive hole, “e⁻” represents an electron and “+OH” represents an OH radical.

[0020] Since the present invention employs a solar battery, the following effects are brought about.

[0021] (a) Since the battery is charged all the time during toothbrushing with the toothbrush under irradiation of a fluorescent lamp in a washroom or the like, or in a well-lighted place where sunlight streams, the photocatalytic action of the n-type semiconductor is not reduced even as operating time goes on, so that the effect of the present invention that generation efficiency of OH radicals is improved to reliably increase the pH is not reduced at all.

[0022] However, in a primary battery, since a gradual voltage drop occurs as operating time goes on, the voltage drops over time to thereby reduce the effect while a user of the toothbrush is not aware of it. It is true of a secondary battery, which is rechargeable as in a solar battery.

[0023] (b) The solar battery, being a thin plate-like, can be well housed along an inner surface of the holder portion even at such a place as the holder portion of the toothbrush, and the holder portion does not need to be thickened more than necessary. The manufacturing cost, therefore, is not increased.

[0024] (c) The service life of a solar battery is generally 20 years or more, which is much longer than a primary battery and longer than a secondary battery. A user of the toothbrush does not need change the battery frequently. Unlike a primary battery, the consumed battery is not frequently disposed.

[0025] (d) The longer service life of a solar battery can hold down the cost, which is advantageous to a toothbrush which is required to be supplied at low cost. In a rechargeable secondary battery, since a battery charger is required and power consumption for charging is entailed, the cost is higher than that of a solar battery.

[0026] (e) In a solar battery, unlike a primary battery and a secondary battery, there occurs no liquid leakage when it is deteriorated. If liquid leakage occurs, there arises a possibility that a short circuit between electrodes occurs, thereby causing heat generation, ignition, disruption or the like. Therefore, it is not preferable to use a primary battery or a secondary battery for the toothbrush. Accordingly, in the case of a primary battery, the battery needs to be removed when not used for a long time, which is troublesome. A solar battery in which such a possibility never arises is best suited for toothbrush.

[0027] In addition, according to the present invention, since an n-type semiconductor is connected to a negative pole of a solar battery, a remarkable sterilizing effect is brought about.

[0028] It is preferable that the TiO_2 is an anatase-type crystal.

[0029] The present configuration is effective and advantageous because such a type of TiO_2 has a particularly large photocatalytic effect among other types of TiO_2 . In this context, an anatase-type crystal can be easily obtained, for example, by the method of heating pure Ti to 1200 to 1500° C. for several minutes in an oxidizing atmosphere.

[0030] Furthermore, an electronic brush according to the present invention is featured by comprising:

[0031] a brush head portion having a bristle portion;

[0032] an n-type semiconductor which is formed of TiO_2 and receives external light; and

[0033] a battery which is a solar battery having an output of more than 0.5 V and less than 3.0 V, connected only to the n-type semiconductor such that the n-type semiconductor is connected to a negative pole of the solar battery, and superimposes an electrical potential on the n-type semiconductor in order to synergistically enhance a photocatalytic effect of the n-type semiconductor.

[0034] According to the present configuration, owing to the photocatalytic action of the n-type semiconductor, in the case of washing each part of a body using soap water and the like, OH radicals generated by decomposition of moisture reliably and rapidly decompose organic waste such as dirt on the skin surface, so that higher washing effect can be

achieved compared to the case where only the soap water is used. In other words, in contrast to the case where the photocatalytic action of the n-type semiconductor is caused by only the external light (e.g. fluorescent lamp in a bathroom or washroom), by superimposing the electric potential of the battery, there can be achieved an energy level required for decomposing organic waste on the skin surface and water, so that the photocatalytic effect of the n-type semiconductor can be improved synergistically. As a consequence, the efficiency of generation of OH radicals can be improved by scrubbing operation of skin surface. Additionally, in the case of practically performing washing operation in a bathroom and the like, even under the condition that light irradiation is weak because illumination of lighting equipment is low, and even if the lighting equipment is an incandescent lamp rather than a fluorescent lamp, since the battery which makes the electric potential of the n-type semiconductor more than or equal to a predetermined value is provided, a desired effect can be stably achieved. As a consequence, according to the present invention, there can be provided an electronic brush capable of washing each part of a body more effectively compared to the case where washing is performed with only soap water.

BRIEF DESCRIPTION OF THE DRAWINGS

[0035] FIG. 1 is a schematic partial section view showing one embodiment of an electronic toothbrush according to the present invention;

[0036] FIG. 2 is a section view along the line II-II of FIG. 1;

[0037] FIG. 3 is a schematic circuit diagram showing an operating state of the electronic toothbrush according to the present invention;

[0038] FIG. 4 is a graph showing a sterilizing effect in the case where the electronic toothbrush according to the present invention is used;

[0039] FIG. 5 is a graph showing test results of a lactic acid decomposition ability of the toothbrush according to the present invention;

[0040] FIG. 6 is a graph showing test results of decomposition of a lactic acid solution in relation to varied voltage of the solar battery according to the present invention;

[0041] FIG. 7 is a schematic partial section view of one embodiment of an electronic brush according to the present invention.

DETAILED DESCRIPTION OF THE PREFERRED EMBODIMENT

[0042] Embodiments of the present invention are described in detail with reference to the drawings. FIG. 1 shows a schematic sectional structure of an electronic toothbrush according to the present embodiment (hereinafter, also referred to simply as "toothbrush"). This toothbrush 1 comprises a brush head portion 2 in which bristles 2a are implanted, and a holder portion 3 to be exposed outside an oral cavity. Preferably, these brush head portion 2 and the holder portion 3 can be separated from each other. In other words, when the head portion 2 having the bristles 2a to be consumed is designed to be replaceable as a consumable item in case of necessary, in addition to the economical

advantage, an advantage of reducing the size of the waste compared to the case where the entire toothbrush is disposed is achieved.

[0043] In the holder portion 3, a TiO₂ rod 4 which is an n-type semiconductor as well as a solar battery 5 of 1.5 V are incorporated, and a negative pole of this battery 5 and the TiO₂ rod 4 are connected to each other via a conductive line 6 such as copper wire. At the interface between the brush head portion 2 and the holder portion 3, there is formed a groove 7 by reducing the section partly in order to facilitate irradiation of the external light to the n-type semiconductor. FIG. 3 is a schematic circuit diagram in an operating state of the electronic toothbrush using the solar battery 5. In this case, the negative pole of the solar battery is connected to the n-type semiconductor, and a voltage is added to a counter pole as a positive pole, whereby the effect as an optical semiconductor is increased that much.

[0044] The TiO₂ rod 4 is formed by heating a rod of pure Ti to 1200 to 1500° C. in an oxidizing atmosphere for several minutes to thereby form a TiO₂ layer on the surface thereof. TiO₂ of this case is anatase-type crystalline and thus possesses an especially large photocatalytic capability. And when the TiO₂ rod 4 receives the external light to give rise to a photocatalytic reaction, the solar battery 5 increases or maintains the electric potential of TiO₂ which is an n-type semiconductor.

EXAMPLES

Example 1

[0045] FIG. 4 shows results of a test in which the effect of the case where a negative pole of a solar battery was connected to an n-typed semiconductor was investigated.

[0046] The test conditions are as follows.

[0047] As test bacteria, Streptococcus mutans IFO 13955 which is considered to be a cause of dental caries was used.

[0048] (i) 4 mL of saline was loaded into a test tube and the test bacteria were inoculated so that a concentration of the test bacteria became about 10,000 to 20,000/mL.

[0049] (ii) The solar battery was used and irradiation by a fluorescent lamp (6 W, at a distance of 10 cm) was conducted at normal temperatures for 1 to 5 minutes.

[0050] (iii) A viable cell number in 1 mL was measured in a standard agar medium.

[0051] An initial propagation number of bacteria was 1.3×10^4 /mL.

[0052] In the accompanying drawing, (A) shows a case where an n-type semiconductor was connected to a negative pole of a solar battery (equivalent to the present invention), (B) shows a case where an n-type semiconductor was connected to a positive pole of a solar battery, and (C) is blank, showing a case where neither n-type semiconductor nor solar battery was used.

[0053] In the case of (A), colonies of Streptococcus mutans decreased rapidly in number for a short time, which shows remarkable effect was exerted. Since a toothbrushing behavior is typically performed for a short time, this result shows the toothbrush according to the present invention has high practicality.

Example 2

[0054] Furthermore, the effect of a lactic acid decomposition ability of the toothbrush according to the present invention was investigated. FIG. 5 shows its test results. This test was conducted in a method of measuring the pH of a lactic acid solution with time.

[0055] A lactic acid solution was blended with 0.3 M potassium sulfate solution and sodium hydrate was further added thereto so as to adjust the pH to about 5.7. 10 mL of this solution was loaded into a glass vessel, a structure using sample electrodes (a solar battery 2.0 V is used. negative pole: TiO₂ electrode, positive pole: stainless electrode) was inserted into the solution, and the solution was light-irradiated by a fluorescent lamp of 6 W and subjected to bubbling with an oxygen gas at 1 L/minute. A distance between the vessel and the fluorescent lamp was about 3 cm. A resistor was connected to the sample electrodes to make predetermined currents (70 μ A, 100 μ A: equivalent to currents flowing in a human body at toothbrushing time) flow between the electrodes. After starting the decomposition, the pH of the lactic acid solution was measured at intervals of 1 minute in conformity to JIS K0101 glass electrode method.

[0056] In either case in which the resistor (A-1: 70 μ A, A-2: 100 μ A) was connected to the sample electrodes, the pH of the lactic acid solution rose for a shorter time than in a blank case (C-1: the solution with neither n-type semiconductor nor a solar battery used)

Example 3

[0057] A decomposition test of a lactic acid solution was conducted in relation to varied voltage of a solar battery. The results were shown in FIG. 6. In this test, 50 mL of about 70 ppm lactic acid liquid was loaded in a flat-bottomed vial (diameter 40×height 75 mm) and electrodes of a negative pole made of an n-type semiconductor with a titanium oxide film formed and a positive pole made of stainless steel were inserted into the resultant lactic acid solution to apply a voltage of 0 to 3 V between these electrodes by a direct current device. The light irradiation was conducted by a fluorescent lamp of 6 W at a distance of 3 cm, and the concentration of lactic acid after a lapse of 24 hours was measured by capillary electrophoresis to investigate the decomposition of lactic acid.

[0058] FIG. 6 shows the decomposition of lactic acid started under a load voltage of about 0.5 V and reached saturation at about 2 V. Accordingly, it is clear that the load voltage of the solar battery starts to exert a lactic acid decomposition effect at 0.5 V, remarkable effect at 1 V, and sufficient effect at 2 V.

[0059] (Other Embodiments of the Invention)

[0060] (1) In the above embodiment, although an example of an electronic toothbrush using TiO₂ which is an n-type semiconductor has been shown, the TiO₂ which is an n-type semiconductor can be used for an electronic brush 10 as shown in FIG. 7. More specifically, in this electronic brush 10, bristles 10a are implanted therein on the front side constituting a brush head portion, and a holder portion is formed on the rear side, into which the solar battery 5 is embedded. This solar battery 5 is embedded in a liquid-tight manner. On the front side where the bristles 10a are implanted, TiO₂ similar to that shown in the above embodi-

ment is attached, while a groove 11 which functions as a water passage is formed in the vicinity of the TiO₂, whereby communication of soap water and the like is enabled. This groove 11 comprises a penetration hole formed toward base portions of the bristles 10a, and is configured so that by scrubbing a body with the bristles 10a, the TiO₂ and the surface of the body are brought into contact with each other via the moisture, thereby facilitating decomposition and removal of organic matters such as dirt existing on the surface by the photocatalytic action of the TiO₂, and also allowing decomposition of the removed organic matters. Incidentally, the TiO₂ and a negative pole of the battery are made conductive via the conductor 6 as shown in FIG. 1. As the n-type semiconductor, the battery and the conductor, those similar to those used in the above embodiment can be used.

[0061] As the shape of the present electronic brush, various shapes other than that shown in FIG. 7 can be employed as long as the electronic brush is formed into a shape which enables washing by scrubbing each part of the body with the bristles while the holder portion being held by a hand. Each part of the body to be washed is not particularly limited, and hence the present electronic brush can be used- as a so-called body brush, hair brush, face brush and the like.

[0062] (2) In the above embodiment, an example in which TiO₂ which is an n-type semiconductor is formed on a Ti rod in layered shape by heating the Ti rod, however not being limited to the above configuration, the TiO₂ may be entirely formed by sintering TiO₂ powder so long as a TiO₂ layer is formed on the light receiving surface. Also the production method may be such that the TiO₂ layer is generated on the conductive surface of a pure Ti rod and the like by the CVD method, PVD method and the like, and that the TiO₂ layer is generated on the surface by anodic oxidation of a pure Ti rod.

[0063] (3) For the electronic toothbrush according to the above embodiment, an example is shown such that the groove 7 is formed at the interface between the brush head portion 2 and the holder portion 3 so as to facilitate irradiation of the external light to TiO₂ which is an n-type semiconductor, however, the brush head portion and the holder portion of the toothbrush maybe formed of a light-permeable material such as transparent or translucent acrylic resin, urethane resin, PET resin and the like, thereby providing a structure without the groove. In addition, when a biodegradable resin is used as a resin for forming the brush head portion 2, influence on the environment is diminished even if the brush head portion 2 is disposed as a consumable item, which is desirable.

What is claimed is:

1. An electronic toothbrush comprising:

- a brush head portion having a bristle portion, to be inserted into an oral cavity, for brushing teeth;
- a holder portion to be exposed outside the oral cavity;
- an n-type semiconductor which is formed of TiO₂ and receives external light; and
- a battery which is a solar battery having an output of more than 0.5 V and less than 3.0 V, connected only to the n-type semiconductor such that the n-type semiconductor is connected to a negative pole of the solar battery,

and superimposes an electrical potential on the n-type semiconductor in order to synergically enhance a photocatalytic effect of the n-type semiconductor.

2. The electronic toothbrush according to claim 1, wherein the TiO_2 is an anatase-type crystal.

3. An electronic brush comprising;

a brush head portion having a bristle portion;

an n-type semiconductor which is formed of TiO_2 and receives external light; and

a battery which is a solar battery having an output of more than 0.5 V and less than 3.0 V, connected only to the n-type semiconductor such that the n-type semiconductor is connected to a negative pole of the solar battery, and superimposes an electrical potential on the n-type semiconductor in order to synergically enhance a photocatalytic effect of the n-type semiconductor.

4. The electronic brush according to claim 3, wherein the TiO_2 is an anatase-type crystal.

* * * * *