

(11) AU-B-77122/91

-2-

(10) 651973

second signal the first signal reproduced by said playback head as a crosstalk component when said playback head scans said preceding track;

scanning a following track by said playback head to reproduce the signals recorded therein and crosstalk components picked up from adjacent tracks;

detecting said third signal reproduced from the scanned following track;

detecting at a time delayed from the detection of said third signal the first signal reproduced by said playback head as a crosstalk component when said playback head scans said following track; and

sensing a difference between the first signal detected when said playback head scans said preceding track and the first signal detected when said playback head scans said following track.

65 1973

S & F Ref: 181418

AUSTRALIA

PATENTS ACT 1990

COMPLETE SPECIFICATION

FOR A STANDARD PATENT

ORIGINAL

Name and Address
of Applicant: Sony Corporation
7-35 Kitashinagawa 6-chome
Shinagawa-KU
Tokyo
JAPAN

Actual Inventor(s): Naofumi Yanagihara

Address for Service: Spruson & Ferguson, Patent Attorneys
Level 33 St Martins Tower, 31 Market Street
Sydney, New South Wales, 2000, Australia

Invention Title: Method and Apparatus for Detecting Tracking Errors

The following statement is a full description of this invention, including the best method of performing it known to me/us:-

BACKGROUND OF THE INVENTION

1
2 This invention relates to tracking error detection and,
3 more particularly, to a method and apparatus for detecting a
4 tracking error in a playback head which scans successive tracks
5 across a record medium.

6 Tracking error control arrangements are known for
7 controlling the position of one or more heads as those heads scan
8 tracks previously recorded on a record medium. For example, in
9 conventional video recording, video signals are recorded on a
10 magnetic tape in successive slant tracks by a helical scan rotary
11 head assembly. When the video signals are reproduced, either by
12 the same head assembly or by different apparatus, the very same
13 slant tracks that had been recorded must be followed accurately
14 for proper signal reproduction and some form of tracking control
15 generally is used for this purpose. Similar tracking control
16 normally is provided when audio signals are recorded in slant
17 tracks, such as in digital audio tape (DAT) recording.

18 In one type of tracking control arrangement, proper
19 positioning of the heads with respect to the slant tracks is
20 carried out with the assistance of a control signal recorded
21 along a longitudinal edge of the magnetic tape. This
22 longitudinally recorded control signal is reproduced by a
23 stationary head; and tape movement is adjusted if there is a

1 phase difference between the reproduced control signal and a
2 position signal representing the rotary position of the heads.
3 For example, proper positioning of a head relative to a track is
4 indicated if the head position signal, which is produced when the
5 head rotates to a predetermined position (e.g. to the beginning)
6 of a track, coincides with a reproduced control signal. In the
7 absence of coincidence, the tape is driven either faster or
8 slower until the head is brought into proper alignment with a
9 track, as represented by such coincidence.

10 A disadvantage of this conventional technique is the
11 requirement of a stationary head which is dedicated to a single
12 function. This head adds to the overall cost of the signal
13 recording/playback apparatus and, more importantly, it impedes
14 miniaturization of that apparatus. If the stationary head can be
15 eliminated, the overall size of the apparatus can be reduced.

16 It has been proposed to mix tracking control signals
17 with information signals in the same slant tracks. This has the
18 advantage of eliminating the aforementioned stationary head and
19 relies upon the transducer which reproduces useful information to
20 reproduce the tracking control signals as well. Digital video
21 and digital audio recording are particularly receptive to this
22 approach because digital information signals are easily
23 multiplexed with control signals without loss of useful

1 information, they may be time base compressed easily and they may
2 be readily processed. Hence, in a particular track, a tracking
3 control signal may be recorded in a restricted region that
4 normally is preceded and followed by digital information signals.

5 In one implementation of this proposal, a pilot signal
6 of predetermined frequency is recorded in alternate tracks, and
7 each pilot signal region is preceded and followed by digital
8 signals. Advantageously, digital video and digital audio signals
9 may be recorded in tracks having no guard bands between them.
10 While this increases the amount of magnetic tape made available
11 to record useful information, it also emphasizes the need for
12 precise tracking control as playback heads scan the respective
13 tracks. Typically, the heads used for recording and/or
14 reproduction exhibit a gap length larger than the width of a
15 track, which means that an edge of a preceding track is
16 overwritten when the next adjacent track is recorded. This also
17 means that when a playback head is in proper alignment with a
18 prerecorded track, the signals recorded in both adjacent tracks
19 are picked up as crosstalk components. This phenomenon of
20 crosstalk pickup is used to detect tracking errors and to provide
21 proper tracking control over the scanning heads.

22 In the arrangement mentioned above, wherein pilot
23 signals of a predetermined frequency are recorded in restricted

1 regions of alternate tracks, a pair of heads is used to scan two
2 adjacent tracks substantially simultaneously. Hence, when one
3 head scans the track in which the pilot signal is recorded, the
4 other head scans the adjacent track which has no pilot signal
5 therein. These two heads are mounted on the same rotary head
6 assembly, such as a rotary head drum, and are relatively closely
7 spaced thereon. The head which scans the track having no pilot
8 signal therein will pick up, as a crosstalk component, the pilot
9 signal recorded in an adjacent preceding track as well as the
10 pilot signal recorded in an adjacent following track. If the
11 magnitude of the crosstalk pilot signal picked up by this head
12 from the preceding track is equal to the magnitude of the pilot
13 signal picked up from the following track, the heads are in
14 proper alignment with respect to the tracks scanned thereby. A
15 tracking error is detected if the crosstalk pilot signal
16 magnitudes from the preceding and following tracks differ from
17 each other. In that event, the tape transport is accelerated or
18 decelerated to bring the heads back into proper tracking
19 alignment.

20 In the foregoing implementation, wherein pilot signals
21 are recorded in restricted regions in alternate tracks, it will
22 be appreciated that when a head scans a track having no pilot
23 signal therein, the pilot signal recorded in the following track

1 will be picked up as a crosstalk component before the pilot
2 signal recorded in the preceding track is picked up. Assuming
3 that the pilot signals are recorded in substantially equal
4 regions in each track, it will be further appreciated that the
5 pilot signals picked up as crosstalk components from the
6 following and preceding tracks will be present concurrently for a
7 significant period of time, and that the pilot signal picked up
8 from the following track will terminate first. Thus, during the
9 scan of a track in which no pilot signals are recorded, there
10 will be distinct intervals of time during which the pilot signal
11 is picked up as a crosstalk component from one adjacent track and
12 then from the other. However, these time intervals are
13 relatively short. Consequently, there is the possibility that
14 the crosstalk pilot signal picked up from one of the adjacent
15 tracks during such short interval may not be detected
16 satisfactorily. Furthermore, this brief time interval is reduced
17 if the track pitch is decreased; and a reduction in track pitch
18 desirably leads to greater recording density. Consequently, if
19 the recording medium is subjected to jitter, the time interval
20 during which one crosstalk pilot signal is picked up may be so
21 small as to inhibit adequate detection. Thus, a tracking error
22 may not be properly sensed and tracking control is degraded.

23

1 nth track. When a preceding track is scanned, the second signal
2 recorded therein is detected; and the first signal, picked up as
3 a crosstalk component when this preceding track is scanned, is
4 detected at a time delayed from the detection of the second
5 signal. When a following track is scanned, the third signal
6 recorded therein is detected; and the first signal, picked up as
7 a crosstalk component when this following track is scanned, is
8 detected at a time delayed from the detection of the third
9 signal. A difference between the first signal detected when the
10 preceding track is scanned and the first signal detected when the
11 following track is scanned is sensed and provides a tracking
12 error indication.

13 In a preferred embodiment, $n = 4$. Also, the first
14 signal is of a predetermined frequency and functions as a pilot
15 signal, whereas the second and third signals exhibit frequencies
16 different from the first signal and function as synchronizing
17 signals. In one embodiment, the frequencies of the second and
18 third signals are equal to each other, and in another embodiment
19 these frequencies are different. In accordance with one aspect
20 of this invention, the first, second and third signals are
21 detected by sensing their respective frequencies.

22 As a feature of this invention, a sampling pulse is
23 generated when the second signal is detected, and after being

1 delayed this sampling pulse is used to sample the first signal
2 picked up as a crosstalk component. Similarly, a sampling pulse
3 is generated when the third signal is detected, and after being
4 delayed this sampling pulse is used to sample the first signal
5 picked up as a crosstalk component. A tracking error is
6 determined by sensing the difference between these respective
7 samples of the first signal. The delay imparted to the
8 respective sampling pulses assures that the first signal, picked
9 up as a crosstalk component, will be sampled at some point of the
10 restricted region in which it is recorded. This delay may be
11 increased or decreased, as desired, and permits accurate
12 detection notwithstanding jitter, reduced track pitch or a
13 particular pilot signal recording format.

14 BRIEF DESCRIPTION OF THE DRAWINGS

15 The following detailed description, given by way of
16 example, will best be understood in conjunction with the
17 accompanying drawings in which:

18 FIG. 1 is a schematic representation of a rotary head
19 assembly that may be used both with the aforementioned prior
20 proposal as well as with the present invention;

21 FIG. 2 is a schematic representation of recording
22 tracks scanned by a pair of playback heads in accordance with the
23 prior proposal mentioned above;

1 FIG. 3 is a schematic representation of recording
2 tracks scanned by a pair of playback heads in accordance with the
3 present invention;

4 FIG. 4 is a block diagram of a preferred embodiment of
5 apparatus in accordance with the present invention; and

6 FIGS. 5A-5E are timing diagrams which are useful in
7 understanding the operation of the present invention.

8 DETAILED DESCRIPTION OF A PREFERRED EMBODIMENT

9 Before describing the present invention, a more
10 detailed explanation of the aforementioned prior proposal of
11 detecting tracking errors will be explained in conjunction with
12 FIGS. 1 and 2. FIG. 1 is a schematic representation of a rotary
13 head assembly wherein a pair of playback heads H_L and H_T are
14 mounted on a rotary head drum 1 about which is partially wrapped
15 a magnetic tape 2. Heads H_L and H_T are designated leading and
16 trailing heads, respectively, and these heads are closely spaced
17 so as to be angularly separated by a relatively short distance
18 GL . In addition, and as will be best appreciated by reference to
19 FIG. 2, heads H_L and H_T are offset from each other in the axial
20 direction of drum 1. This offset is substantially equal to the
21 pitch of the tracks scanned thereby. Although FIG. 1 illustrates
22 tape 2 as being wrapped about a peripheral surface of drum 1 by
23 an angular extent of more than 90° , it will be appreciated that

1 this wrap angle may be much greater, for example, greater than
2 300° and preferably greater than 330°. As a result of a large
3 wrap angle and closely spaced heads, the leading and trailing
4 heads function to scan substantially simultaneously a pair of
5 tracks at each rotation of drum 1. If the wrap angle is large
6 enough, only two heads need be used to scan successive pairs of
7 tracks.

8 The arrangement shown in FIG. 1, wherein a pair of
9 heads is mounted on a rotatable drum in closely spaced but
10 axially offset relationship offers significant advantages over
11 previously proposed mounting arrangements wherein two heads are
12 mounted 180° apart. Tracks which are recorded by diametrically
13 opposed heads may not be in alignment with each other because the
14 rotary movement of the drum to scan one head across the tape may
15 not be precisely the same as the rotary movement thereof to scan
16 the other head. This difficulty is, of course, avoided when the
17 heads are closely spaced to each other because both heads will be
18 subjected to the very same irregularities that may be present in
19 the drum rotation. Hence, the scanning trace of head H_1 is
20 practically identical to the scanning trace of head H_2 , and the
21 resultant tracks scanned thereby are in precise alignment. Good
22 effects are achieved even if the track pitch is made very small.

1 The track pattern scanned by heads H_L and H_T in FIG. 1
2 is illustrated schematically in FIG. 2. In this track pattern,
3 the pilot signal of frequency f_0 is recorded in alternate tracks,
4 such as in odd tracks T_1, T_3, T_5 , etc. In accordance with the
5 proposal made heretofore, the duration of the pilot signal is
6 controlled such that the pilot signal is recorded in a restricted
7 region in a track. The frequency of the pilot signal is on the
8 order of several hundreds of kHz, but its frequency is such as to
9 exhibit relatively small azimuth loss. As is typical in video
10 recording, heads H_L and H_T exhibit different azimuths such that
11 the phenomenon of azimuth loss minimizes the crosstalk component
12 picked up by one head from a track that was recorded by a
13 different head. For example, if it is assumed that leading head
14 H_L scans odd tracks T_1, T_3, T_5 , etc. during both recording and
15 reproducing operations, and if it also is assumed that trailing
16 head H_T scans the even tracks T_2, T_4 , etc., during both recording
17 and reproducing, then azimuth loss will minimize the signals
18 picked up by head H_L from adjacent even tracks and, similarly,
19 azimuth loss will minimize the signals picked up by head H_T from
20 adjacent odd tracks. That is, when head H_L scans track T_3 during
21 a playback operation, azimuth loss will minimize the signals
22 picked up as crosstalk components from tracks T_2 and T_4 .
23 Similarly, when head H_T scans track T_2 during a playback

1 operation, azimuth loss will minimize the crosstalk components
2 picked up by head H_r from tracks T_1 and T_3 . However, the
3 frequency of pilot signal f_0 is not subjected to significant
4 azimuth loss and will be picked up as a crosstalk component by
5 head H_r when this head scans an even track.

6 When heads H_l and H_r scan the odd and even tracks, as
7 illustrated in FIG. 2, pilot signal f_0 is reproduced when head H_l
8 reaches a point t_0 in track T_1 . Because of the spacing GL
9 between heads H_l and H_r , head H_r reaches point t'_0 in track T_2 when
10 head H_l first detects the pilot signal. It is seen that points
11 t_0 and t'_0 are spaced apart by the distance GL , the same spacing
12 exhibited between heads H_l and H_r . It is recognized that, when
13 head H_l first detects the pilot signal, head H_r is sufficiently
14 distant therefrom as not to pick up a pilot signal crosstalk
15 component, as yet. Rather, it is not until head H_r advances to
16 the position t_1 in track T_2 that a crosstalk pilot signal
17 component will be picked up by this head from adjacent track T_3 .
18 It is seen that head H_r reaches point t_1 at a delayed time t_a from
19 point t'_0 . That is, at this delayed time t_a , head H_r picks up a
20 crosstalk pilot signal component from only one adjacent track,
21 namely the right track T_3 .

22 From FIG. 2, it is apparent that head H_r reaches a
23 portion of track T_2 whereat pilot signals f_0 are picked up as

1 crosstalk components simultaneously from the left adjacent track
2 T_1 and from the right adjacent track T_3 . During the time that
3 the pilot signal is picked up from both adjacent tracks, a
4 determination cannot be made with respect to a tracking error.
5 Hence, the tracking error detecting circuitry normally used with
6 the arrangement shown in FIG. 2 is disabled or otherwise
7 inhibited during the period of time that head H_1 picks up pilot
8 signal crosstalk components from both tracks adjacent the track
9 being scanned thereby.

10 When head H_1 reaches the point t_2 as it scans track T_2 ,
11 the pilot signal crosstalk component picked up from the right
12 adjacent track T_3 no longer is detected, and the pilot signal
13 crosstalk component now is picked up from only the left adjacent
14 track T_1 . FIG. 2 illustrates that head H_1 arrives at point t_2 at
15 a delayed time t_b from point t'_0 . Preferably, the pilot signal
16 crosstalk component picked up from, for example, track T_3 is
17 detected separately from the pilot signal crosstalk component
18 picked up from track T_1 . A tracking error is determined by
19 sensing the difference between these separately detected pilot
20 signal crosstalk components. For example, if the magnitude of
21 one pilot signal crosstalk component exceeds the magnitude of the
22 other, it is concluded that the heads are not properly centered
23 on the tracks and the tape is accelerated or decelerated to

effect a shifting in the heads relative to the tracks scanned thereby. Hence, tracking errors are corrected.

In the proposal represented by FIG. 2, a pilot signal of only one frequency is recorded in alternate tracks. However, as discussed above, the time interval during which the pilot signal may be detected by head H_T as a crosstalk component picked up from only one adjacent track is relatively brief. For example, the pilot signal picked up from the right adjacent track is detected only during the relatively brief interval t_c , and the pilot signal picked up from the left adjacent track is detected only during the relatively brief interval t_d . Between these intervals, the pilot signal is picked up from both adjacent tracks. This brief interval t_c or t_d is a function of the difference d between the start of successive tracks. This difference d becomes smaller as the track pitch is reduced; and this results in decreasing the interval t_c or t_d during which the pilot signal may be detected from only one adjacent track. Indeed, this interval t_c or t_d may be expressed as follows:

$$t_c = t_d = \frac{2(v_T/f_0) \cos \phi}{v_R} \quad \text{[seconds]}$$

where v_T is the speed at which the tape is transported, f_0 is twice the drum rotation rate, ϕ is the recording angle (that is,

1 the angle of a track relative to the longitudinal direction of
2 the tape) and v_r is the speed of the head relative to the tape as
3 both the head and tape move. As the time interval t_c or t_d is
4 reduced, jitter in the tape movement may prevent accurate
5 detection of the pilot signal picked up from an adjacent track,
6 thus degrading the tracking error operation.

7 The present invention overcomes this difficulty
8 associated with the proposal shown in FIG. 2 by recording pilot
9 and synchronizing signals in accordance with the track pattern
10 shown in FIG. 3. It will be appreciated that heads H_l and H_r ,
11 which are used to scan two adjacent tracks substantially
12 simultaneously, may be mounted on a rotary drum consistent with
13 the configuration shown in FIG. 1. Thus, the heads are closely
14 spaced and offset from each other in the axial direction of the
15 drum by an amount substantially equal to the pitch of the tracks.
16 Furthermore, the heads exhibit different azimuth angles so as to
17 attenuate crosstalk picked up from adjacent tracks, except that a
18 pilot signal picked up as a crosstalk component will not be
19 significantly attenuated.

20 In the embodiment illustrated in FIG. 3, it is assumed
21 that head H_l scans odd tracks T_{11} , T_{13} , T_{15} , etc. and head H_r scans
22 even tracks T_{12} , T_{14} , T_{16} , etc. A pilot signal f_i of a frequency
23 that is not significantly attenuated by azimuth loss is recorded

1 in a restricted region in every n th track, where n is an even
2 number equal to or greater than 4. In the preferred embodiment,
3 as illustrated in FIG. 3, $n = 4$. Thus, the pilot signal f_1 is
4 recorded in tracks T_{13} , T_{17} , etc. The pilot signal is recorded
5 for a predetermined duration and commences at a fixed interval
6 from the beginning portion of the track in which it is recorded.
7 A synchronizing signal f_2 is recorded in a restricted region in a
8 track which precedes the track containing the pilot signal.
9 Thus, synchronizing signal f_2 is recorded in tracks T_{12} , T_{16} , etc.
10 The synchronizing signal exhibits a predetermined frequency
11 different from the pilot signal frequency and preferably is
12 greater than the pilot signal frequency so as to be subjected to
13 azimuth loss. The duration of the synchronizing signal is not
14 critical, and in the illustrated embodiment this duration is less
15 than the duration during which pilot signal f_1 is recorded. As
16 will be appreciated below, the length and position of
17 synchronizing signal f_2 is such that, after the signal is
18 detected by, for example, head H_1 , the pilot signal f_1 is picked
19 up as a crosstalk component by this head.

20 Similarly, a synchronizing signal f_3 is recorded in a
21 restricted region in a track which follows and is adjacent to
22 each track in which the pilot signal is recorded. As shown,
23 synchronizing signal f_3 is recorded in tracks T_{14} , T_{18} , etc. The

1 synchronizing signal preferably is of a frequency higher than the
2 frequency of pilot signal f_1 and, thus, is subject to azimuth
3 loss. In one embodiment, the synchronizing signals f_2 and f_3 are
4 of the same frequency. In an alternative embodiment, the
5 frequencies of these synchronizing signals differ from each
6 other. The duration of synchronizing signal f_3 and its
7 particular location relative to the pilot signal recorded in the
8 adjacent track are not critical; however, it will become apparent
9 that synchronizing signal f_3 is located such that after it is
10 detected by, for example, head H_1 , this head picks up pilot
11 signal f_1 as a crosstalk component. In the illustrated
12 embodiment, the duration of synchronizing signal f_3 is shorter
13 than that of pilot signal f_1 .

14 It will be recognized that in those regions of each
15 track which precede and follow a respective pilot or
16 synchronizing frequency, useful information is recorded, such as
17 digital video or digital audio information. Of course, useful
18 information is recorded in substantially the entire length of
19 those tracks having neither a pilot signal nor a synchronizing
20 signal recorded therein. As illustrated, tracks T_{11} , T_{15} , etc.,
21 have such useful information recorded therein.

22 One embodiment of apparatus for detecting a tracking
23 error from the pilot and synchronizing signal pattern illustrated

1 in FIG. 3 is shown as a block diagram in FIG. 4. For the purpose
2 of this description, it is assumed that head H_T scans the even
3 tracks to reproduce the synchronizing signals f_2 and f_3 and to
4 pick up pilot signal f_1 as a crosstalk component. It will be
5 appreciated, however, that head H_L may be used to record and
6 reproduce these even tracks.

7 The tracking error detector shown in FIG. 4 is
8 comprised of individual signal detectors connected in common to
9 head H_T by a playback preamplifier 11. These detectors include a
10 synchronizing signal detector adapted to detect synchronizing
11 signal f_2 , a synchronizing signal detector adapted to detect
12 synchronizing signal f_3 and a pilot signal detector adapted to
13 detect pilot signal f_1 . To discriminate these signals reproduced
14 or picked up by head H_T , filters are used, each tuned to a
15 respective frequency and thus operable to pass either
16 synchronizing signal f_2 , synchronizing signal f_3 or pilot signal
17 f_1 . These filters are illustrated as band pass filters having
18 center frequencies tuned to the frequency of the particular
19 signal adapted to be passed thereby.

20 The pilot signal detector is comprised of a band pass
21 filter 12 coupled to the output of preamplifier 11 and adapted to
22 pass the pilot signal frequency. The output of the band pass
23 filter is coupled to an envelope detector 13 which produces a

1 signal whose amplitude is proportional to the magnitude of the
2 pilot signal picked up by head H_r as a crosstalk component. The
3 detected envelope of the pilot signal is supplied in common to
4 sample-and-hold circuits 14 and 15 which function to sample the
5 pilot signal envelope. The sampling pulses used by these sample-
6 and-hold circuits are generated by the synchronizing signal
7 detectors, as will be described. A difference circuit 16, such
8 as a comparator, is coupled to the sample-and-hold circuits 14
9 and 15 to determine the difference between the pilot signal
10 samples produced thereby. This difference is indicative of a
11 tracking error and is supplied to an output terminal 18 by way of
12 a switch 17. This switch is adapted to be closed by a sampling
13 pulse generated by one of the synchronizing signal detectors.

14 The synchronizing signal detector adapted to detect
15 synchronizing signal f_2 includes a band pass filter 21 which is
16 coupled to the output of preamplifier 11 and is tuned to the
17 frequency of this synchronizing signal. The envelope of the
18 synchronizing signal passed by band pass filter 21 is detected by
19 an envelope detector 22, and the level of the detected envelope
20 is compared to a reference level by a comparator 23. It will be
21 appreciated that comparator 23 functions as a threshold circuit
22 and is adapted to generate an output pulse when the envelope of
23 synchronizing signal f_2 exceeds the threshold level represented

1 by the reference signal supplied to this comparator. The pulse
2 produced by comparator 23 is coupled to sample-and-hold circuit
3 14 as a sampling pulse after being delayed by a delay circuit 24.
4 The delay circuit imparts a predetermined time delay to the
5 sampling pulse generated by comparator 23 for a purpose soon to
6 be described.

7 The synchronizing signal detector adapted to detect
8 synchronizing signal f_3 is of substantially the same construction
9 as the synchronizing signal detector used to detect synchronizing
10 signal f_2 . As shown, a band pass filter 31, tuned to the
11 frequency of synchronizing signal f_3 , is coupled to the output of
12 preamplifier 11 and is adapted to pass synchronizing signal f_3 to
13 an envelope detector 32. The envelope of synchronizing signal
14 f_3 , which represents the magnitude thereof, is compared by a
15 comparator 33 to a threshold level supplied thereto by a
16 reference signal source. The comparator functions as a threshold
17 detector to produce a sampling pulse when the envelope of
18 synchronizing signal f_3 exceeds this threshold. The sampling
19 pulse generated by comparator 33 is supplied to sample-and-hold
20 circuit 15 via a delay circuit 34. This sampling pulse also is
21 used to close output switch 17.

22 It will be appreciated that, for the embodiment wherein
23 the frequencies of both synchronizing signals are the same, band

1 pass filters 21 and 31 may be substantially identical.
2 Conversely, if the frequencies of these synchronizing signals
3 differ from each other, the center frequencies of the respective
4 band pass filters likewise differ from each other. Still
5 further, delays imparted by delay circuits 24 and 34 to the
6 sampling pulses generated by comparators 23 and 33, respectively,
7 may be equal. As mentioned above, the purpose of these delays is
8 discussed below, and it will become apparent that such delays
9 need not be equal to each other.

10 The manner in which the tracking error detector shown
11 in FIG. 4 operates now will be described in conjunction with FIG.
12 3 and the timing diagrams of FIGS. 5A-5E. Let it be assumed that
13 head H_L scans the odd tracks shown in FIG. 3 and that head H_T
14 scans the even tracks. FIG. 5A is a timing waveform representing
15 a switching pulse, and it is assumed that heads H_L and H_T begin
16 the scanning of their respective tracks at the positive
17 transition of the switching pulse. It will be appreciated that
18 the period of the switching pulse corresponds to the rotational
19 period of head drum 1 and that the wrap angle of tape 2 deployed
20 about the drum is such that the pair of heads H_L and H_T scan
21 successive pairs of tracks across the tape. Thus, these heads
22 scan track pairs $T_{11}, T_{12}; T_{13}, T_{14}; T_{15}, T_{16};$ etc. In the
23 illustrated embodiment, the synchronizing and pilot signals are

1 recorded in their respective tracks at the vicinity of the
2 beginning portion of such tracks. Useful information may precede
3 as well as follow the restricted regions in which these
4 respective synchronizing and pilot signals are recorded.

5 When head H_T scans track T_{12} , synchronizing signal f_2 is
6 detected when the head reaches point t_{10} . The synchronizing
7 signal reproduced by this head is passed to envelope detector 22
8 by band pass filter 21 and compared to a threshold level by
9 comparator 23. Assuming that the magnitude of the synchronizing
10 signal exceeds this threshold level, comparator 23 generates an
11 output pulse as shown in FIG. 5B.

12 As head H_T scans track T_{12} , the pilot signal f_1 recorded
13 in the right adjacent track T_{13} is picked up and is passed by
14 band pass filter 12. The magnitude of this pilot signal
15 crosstalk component is detected by envelope detector 13 and is
16 supplied to sample-and-hold circuit 14. From the track pattern
17 shown in FIG. 3, it is expected that the pilot signal is picked
18 up before synchronizing signal f_2 is detected, and this pilot
19 signal is continuously picked up for a substantial period of
20 time, even after head H_T passes beyond synchronizing signal f_2 .
21 Delay circuit 24 delays the sampling pulse shown in FIG. 5B by a
22 time delay t_A such that when head H_T reaches point t_{11} (shown in
23 FIG. 3), the delayed sampling pulse is generated, as represented

1 by the timing waveform of FIG. 5D. If this time delay t_A is
2 greater than the interval during which synchronizing signal f_2 is
3 reproduced, interference between this synchronizing signal and
4 the pilot signal crosstalk component is avoided. At the delayed
5 time t_A , that is, when head H_r reaches point t_{11} , the pilot signal
6 magnitude supplied by envelope detector 13 to sample-and-hold
7 circuit 14 is sampled. This pilot signal sample is held at least
8 until sample-and-hold circuit 15 is operated. In any event, the
9 sample held by sample-and-hold circuit 14 may be reset prior to
10 the next sampling operation thereof.

11 Now, when heads H_l and H_r scan the next track pair,
12 shown as tracks T_{13} and T_{14} , a similar operation is carried out
13 with the synchronizing signal detector used to detect
14 synchronizing signal f_3 . That is, when head H_r now reaches
15 synchronizing signal f_3 in track T_{14} , as represented by point t_{20} ,
16 this synchronizing signal is reproduced, passed to envelope
17 detector 32 by band pass filter 31 and compared to a threshold
18 level by comparator 33. Assuming that the magnitude of
19 synchronizing signal f_3 exceeds this threshold level, comparator
20 33 generates a sampling pulse as illustrated in FIG. 5C. At this
21 time, head H_r has not yet reached the vicinity of the region in
22 which pilot signal f_1 is recorded. Hence, a pilot signal
23 crosstalk component is not yet picked up from adjacent track T_{13} .

1 Of course, as the head continues its scan of track T_{14} , this
2 pilot signal crosstalk component will be picked up.

3 Delay circuit 34 delays the sampling pulse produced by
4 comparator 33 by a time delay t_b , as illustrated in FIG. 5E.
5 Accordingly, the delayed sampling pulse is produced by delay
6 circuit 34 when head H_r reaches point t_{21} in track T_{14} , as shown in
7 FIG. 3. At this time, the head has passed beyond synchronizing
8 signal f_3 and picks up pilot signal f_1 as a crosstalk component
9 from adjacent track T_{13} . It will be seen that, at point t_{21} ,
10 there is no interference between the pilot signal and
11 synchronizing signal f_3 . This delayed sampling pulse now samples
12 the magnitude of the pilot signal crosstalk component picked up
13 from adjacent track T_{13} . This sample of the pilot signal,
14 produced when head H_r scans the right adjacent track T_{14} now is
15 compared to the sample of the pilot signal crosstalk component
16 picked up when head H_r scanned the left adjacent track T_{12} , which
17 sample is stored in sample-and-hold circuit 14. Any difference
18 between these pilot signal samples is determined by difference
19 circuit 16 and supplied to output terminal 18 as a tracking error
20 indication. Sample-and-hold circuit 15 may be reset before the
21 next sampling operation thereof.

22 Thus, a pilot signal sample produced when head H_r scans
23 the track which precedes and is adjacent to track T_{13} in which

1 pilot signal f_1 is recorded is compared to the pilot signal
2 sample produced when this head scans the track which follows and
3 is adjacent to track T_{13} . If the heads exhibit proper track
4 alignment, the magnitudes of these samples will be equal.
5 However, if the alignment of the heads is left-of-center, the
6 pilot signal sample produced when the following track T_{14} is
7 scanned will be greater than the pilot signal sample produced
8 when the preceding track T_{12} is scanned, resulting in a tracking
9 error indication. The tracking error signal produced at output
10 terminal 18 is supplied to a servo circuit (not shown) which, for
11 example, controls the operation of a capstan motor to transport
12 the magnetic tape in a manner to correct this tracking error.
13 Conversely, if the pilot signal sample produced when head H_1
14 scans the preceding track T_{12} is greater than the pilot signal
15 sample produced when the head scans the following track T_{14} , it
16 is concluded that the alignment of the heads is right-of-center;
17 and the tracking error signal produced by difference circuit 16
18 is indicative thereof. The aforementioned servo circuit responds
19 to this tracking error signal to control the tape transport and
20 thereby correct the tracking error.

21 From the foregoing, it will be seen that the detection
22 of the crosstalk pilot signal is not dependent upon the track
23 format, as is the case in the arrangement shown in FIG. 2.

1 Hence, the duration of the time period during which the crosstalk
2 pilot signal is picked up and detected is relatively longer than
3 that discussed above in conjunction with FIG. 2. Consequently,
4 the possibility of jitter will not prevent proper detection of
5 the pilot signal crosstalk component.

6 In the embodiment discussed with reference to FIGS. 3
7 and 4, it has been assumed that the frequencies of synchronizing
8 signals f_2 and f_3 differ from each other. As an alternative,
9 these frequencies may be equal. Of course, when a synchronizing
10 signal is detected, it must be known whether the track in which
11 this synchronizing signal is recorded precedes or follows the
12 track in which the pilot signal is recorded. But, since head H_L
13 scans the track in which the pilot signal is recorded during the
14 same pass that head H_r scans the following, adjacent track, the
15 determination of whether the head H_r is scanning the preceding or
16 following track is easily determined. That is, it is known that
17 head H_r scans a preceding track if head H_L does not reproduce the
18 pilot signal; and it is known that head H_r scans the following
19 track when head H_L reproduces the pilot signal.

20 While the present invention has been particularly shown
21 and described with reference to a preferred embodiment, it will
22 be readily appreciated by those of ordinary skill in the art that
23 various changes and modifications may be made without departing

1 from the spirit and scope of the invention. Some of these
2 changes have been discussed above. In addition to those, the
3 configuration of the heads mounted on drum 1 need not be limited
4 solely to the representation shown in FIG. 1. If the drum and
5 tape movements can be controlled sufficiently so as to exhibit
6 accurate scanning, the heads may be mounted 180° apart, provided
7 that the heads are capable of reproducing the synchronizing and
8 pilot signals recorded in the pattern shown in FIG. 3. That is,
9 such diametrically opposed heads may be used, whereby one head
10 scans odd tracks T₁₁, T₁₃, T₁₅, etc. and the other head scans even
11 tracks T₁₂, T₁₄, T₁₆, etc.

12 It is intended that the appended claims be interpreted
13 as including the embodiment described herein, those alternatives
14 which have been discussed above and all equivalents.

The claims defining the invention are as follows:
~~WHAT IS CLAIMED IS:~~

1. A method of detecting a tracking error in a playback head which scans tracks across a record medium having a first signal recorded in a restricted region in every n th track, ^{wherein n is an even integer at least equal to 4} a second signal recorded in a restricted region in a track which precedes and is adjacent to each track in which said first signal is recorded, and a third signal recorded in a restricted region in a track which follows and is adjacent to each track in which said first signal is recorded, said method comprising the steps of:

scanning a preceding track by said playback head to reproduce the signals recorded therein and crosstalk components picked up from adjacent tracks;

detecting said second signal reproduced from the scanned preceding track;

detecting at a time delayed from the detection of said second signal the first signal reproduced by said playback head as a crosstalk component when said playback head scans said preceding track;

scanning a following track by said playback head to reproduce the signals recorded therein and crosstalk components picked up from adjacent tracks;

detecting said third signal reproduced from the scanned following track;

detecting at a time delayed from the detection of said third signal the first signal reproduced by said playback head as a crosstalk component when said playback head scans said following track; and

sensing a difference between the first signal detected when said playback head scans said preceding track and the first signal detected when said playback head scans said following track.

2. The method of Claim 1 wherein $n=4$.

3. The method of Claim 1 wherein said first signal is a pilot signal of predetermined frequency and said second and third signals exhibit frequencies different from said first frequency.

4. The method of Claim 3 wherein the frequency of said second signal differs from the frequency of said third signal.

5. The method of Claim 3 wherein the frequency of said second signal is equal to the frequency of said third signal.

6. The method of Claim 3 wherein each step of detecting comprises sensing the respective frequency of said first, second and third signals.

7. The method of Claim 6 wherein said step of detecting the first signal when said playback head scans said preceding track comprises filtering the frequency of said first signal, generating a first sampling pulse at a predetermined time delay from the sensing of the frequency of said second signal, and using said first sampling pulse to sample the filtered first signal.

8. The method of Claim 7 wherein said step of detecting the first signal when said playback head scans said following track comprises filtering the frequency of said first signal, generating a second sampling pulse at a predetermined time delay from the sensing of the frequency of said third signal, and using said second sampling pulse to sample the filtered first signal.

9. The method of Claim 8 wherein said step of sensing a difference comprises holding samples of the filtered first signal sampled by the respective first and second sampling pulses, and obtaining the difference between the held samples.

10. The method of Claim 9 wherein said step of sensing a difference further comprises providing as an output signal representative of a tracking error the difference between the held samples in response to said second sampling pulse.

11. Apparatus for detecting a tracking error in

transducer means which scans tracks across a record medium having
a first signal recorded in every ^{wherein n is an even integer at least equal to 4} n th track, a second signal
recorded in a track which precedes and is adjacent to each n th
track, and a third signal recorded in a track which follows and
is adjacent to each n th track, said apparatus comprising:

second signal detecting means for detecting said second
signal when said transducer means scans a preceding track;

third signal detecting means for detecting said third
signal when said transducer means scans a following track;

first signal detecting means operable when said
transducer means scans said preceding track to detect, at a time
delayed from the detection of said second signal, the first
signal picked up as a crosstalk component by said transducer
means, and operable when said transducer means scans said
following track to detect, at a time delayed from the detection
of said third signal, the first signal picked up as a crosstalk
component by said transducer means; and

sensing means for sensing a difference between the
first signal detected by said first signal detecting means when
said transducer means scans said preceding track and the first
signal detected by said first signal detecting means when said
transducer means scans said following track.

12. The apparatus of Claim 11 wherein $n=4$.

13. The apparatus of Claim 11 wherein said first signal is a pilot signal of predetermined frequency and said second and third signals exhibit frequencies different from said first frequency.

14. The apparatus of Claim 13 wherein the frequency of said second signal differs from the frequency of said third signal.

15. The apparatus of Claim 13 wherein the frequency of said second signal is equal to the frequency of said third signal.

16. The apparatus of Claim 13 wherein each of said detecting means includes frequency sensing means for sensing the respective frequency of said first, second and third signals.

17. The apparatus of Claim 13 wherein said first signal detecting means comprises filtering means tuned to the frequency of said first signal for filtering said first signal, first sampling pulse generating means for generating a first sampling pulse at a predetermined time delay from the detection of said second signal, second sampling pulse generating means for generating a second sampling pulse at a predetermined time delay from the detection of said third signal, and sampling means for sampling the filtered first signal with said first and second sampling pulses.

18. The apparatus of Claim 17 wherein said sampling means comprises first sample-and-hold means responsive to said first sampling pulse for sampling and holding the filtered first signal, and second sample-and-hold means responsive to said second sampling pulse for sampling and holding the filtered first signal.

19. The apparatus of Claim 18 wherein said sensing means comprises difference means coupled to said first and second sample-and-hold means for obtaining a difference between the samples held thereby.

20. The apparatus of Claim 19 wherein each of said second and third signal detecting means includes filter means tuned to a respective frequency of the second and third signals for filtering said respective second or third signal.

21. The apparatus of Claim 20 wherein each of said first and second sampling pulse generating means includes envelope detecting means for detecting an envelope of the respective second or third signal, comparator means for generating a sampling pulse if the detected envelope exceeds a predetermined level, and delay means for delaying the generated sampling pulse.

22. The apparatus of claim 19 wherein said sensing means further includes output switch means responsive to said

second sampling pulse for providing said difference between the samples as a tracking error signal.

23. The apparatus of Claim 11 wherein said transducer means comprises one of a pair of closely spaced playback heads operable to scan two adjacent tracks substantially concurrently.

24. The apparatus of Claim 23 wherein the pair of playback heads exhibit different azimuth angles.

25. The apparatus of Claim 23 wherein said transducer means comprises a rotary head drum rotatable about an axis thereof, and said pair of playback heads are mounted on said drum offset from each other in the axial direction by an amount substantially equal to the pitch of said tracks.

26. A method of detecting a tracking error in a playback head substantially as hereinbefore described with reference to Figures 3 and 5 of the drawings.

27. Apparatus for detecting a tracking error in a transducer means substantially as hereinbefore described with reference to Figures 4 and 5 of the drawings.

DATED this FIFTEENTH day of MAY 1991
Sony Corporation

Patent Attorneys for the Applicants
SPRUSON & FERGUSON

Method and Apparatus for Detecting Tracking Errors

Abstract of the Disclosure

Tracks (T) scanned by a playback head (H_2, H_T) are provided with a first signal (f_1) recorded in every nth track (T_{17}, T_{17}), a second
5 signal (f_2) recorded in a track (T_{12}, T_{16}) which precedes and is adjacent to each nth track and a third signal (f_3) recorded in a track (T_{14}, T_{18}) which follows and is adjacent to each nth track. When a preceding track is scanned, the second signal (f_2) recorded therein is detected; and at a time delayed from the detection of that second signal,
10 the first signal, (f_1) picked up as a crosstalk component is sensed. When a following track is scanned, the third signal (f_2) recorded therein is detected; and at a time delayed from the detection of the third signal, (f_3), the first signal (f_1) picked up as a crosstalk component is sensed. The difference between the first signal sensed when
15 a preceding track is scanned and the first signal sensed when a following track is scanned is indicative of a tracking error.

(Figure 3)

77122/91

FIG. 1

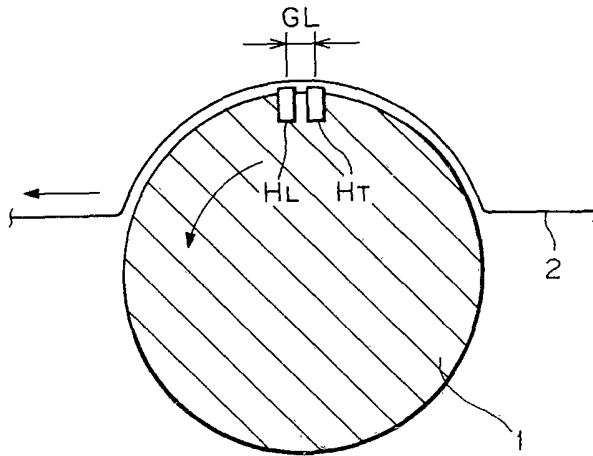

FIG. 2

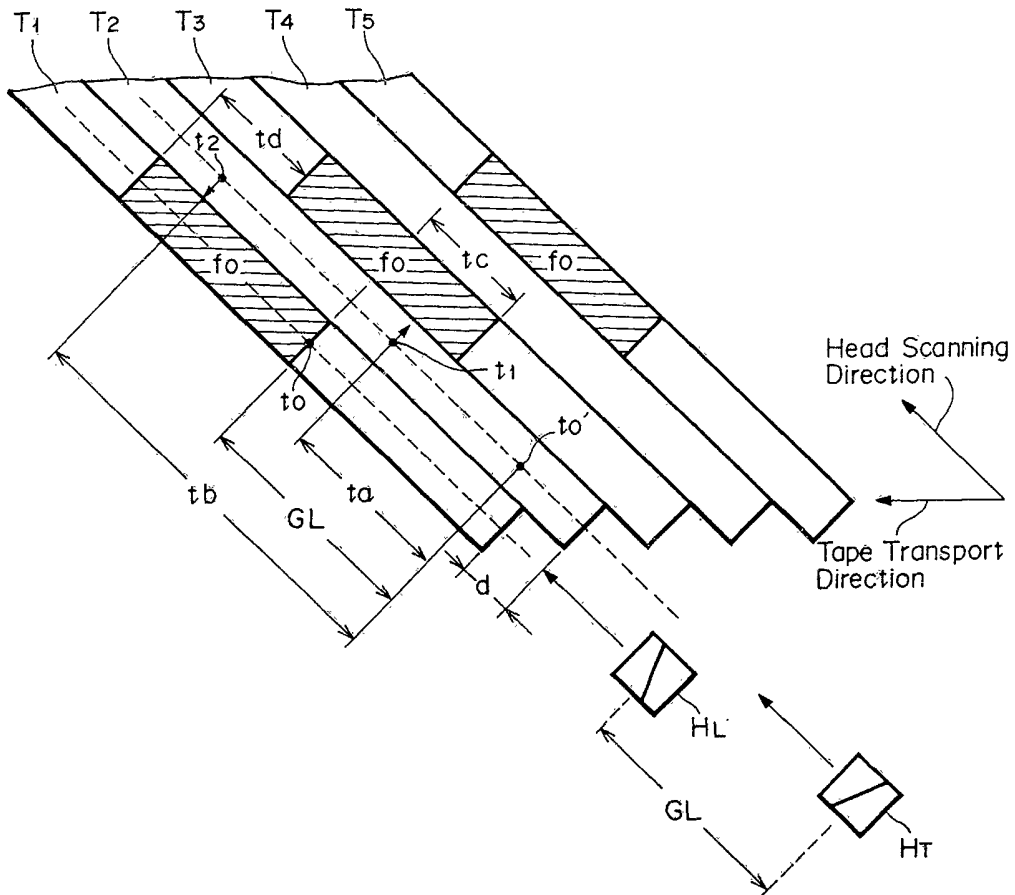

FIG. 3

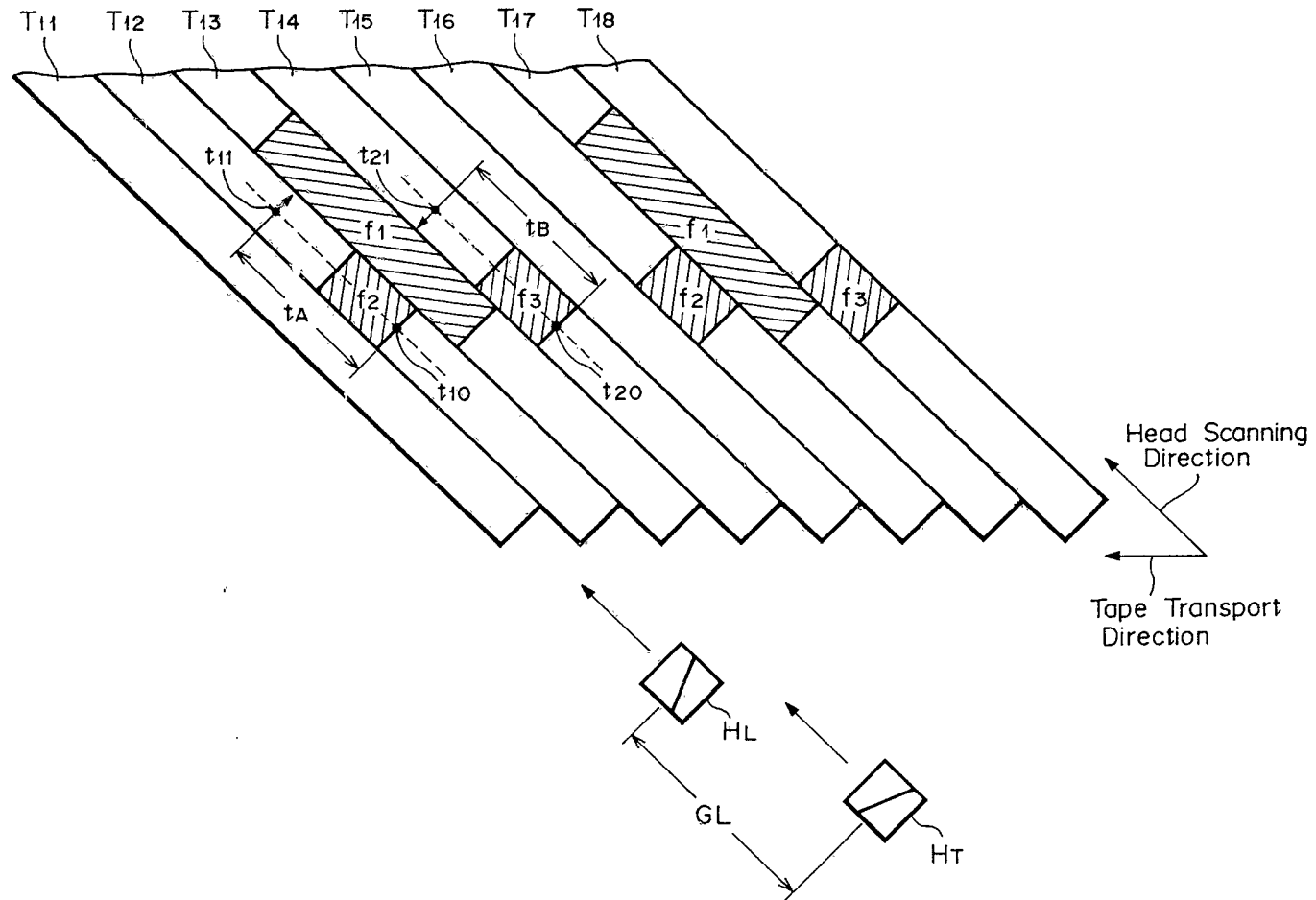

FIG. 4

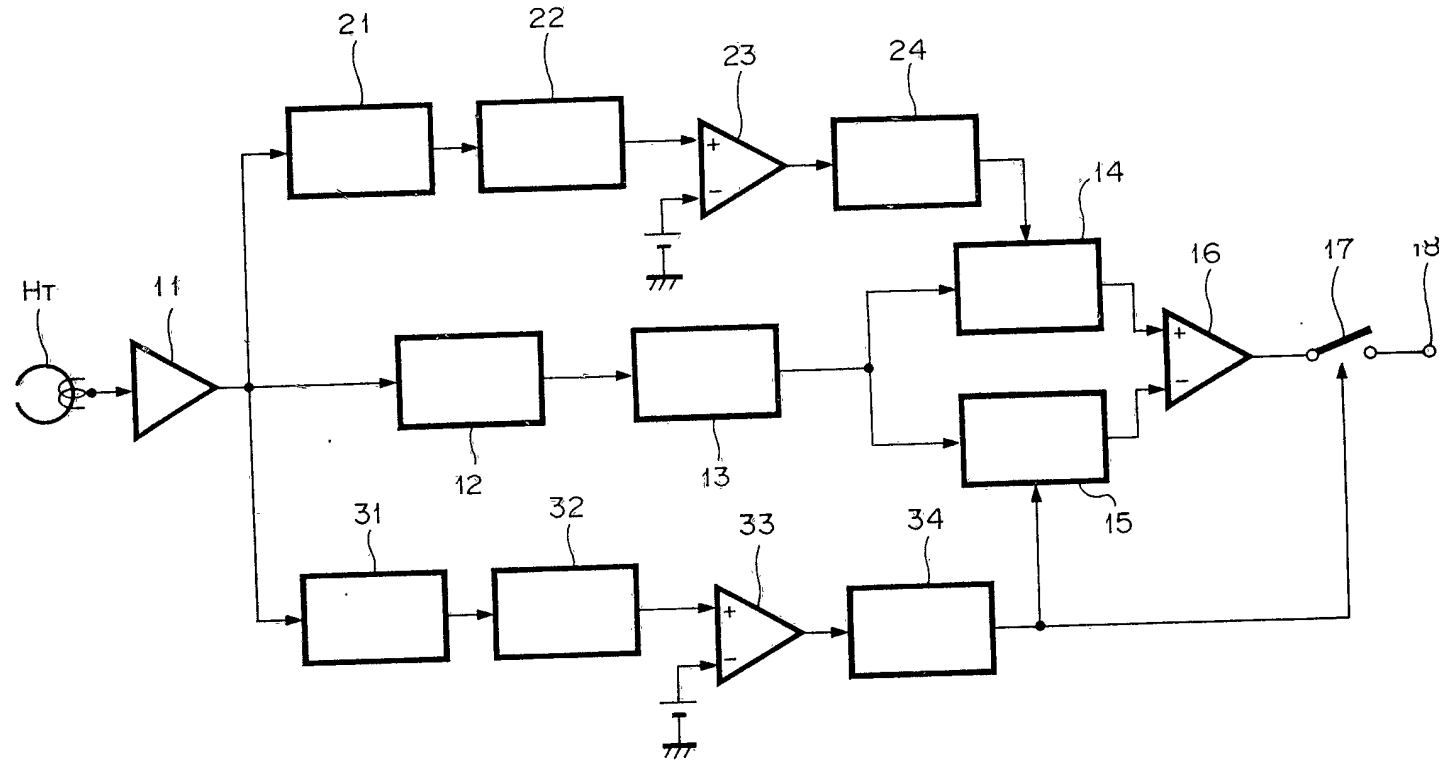

FIG. 5A Switching Pulse

FIG. 5B Detected Sync. Signal f_2

FIG. 5C Detected Sync. Signal f_3

FIG. 5D 1st Sampling Pulse

FIG. 5E 2nd Sampling Pulse

