



(51) International Patent Classification:
E21B 43/117 (2006.01)

(21) International Application Number:
PCT/US2014/059894

(22) International Filing Date:
9 October 2014 (09.10.2014)

(25) Filing Language: English

(26) Publication Language: English

(30) Priority Data:
14/286,587 23 May 2014 (23.05.2014) US

(71) Applicant: HUNTING TITAN, INC. [US/US]; 11785 Highway 152, Pampa, TX 79065 (US).

(72) Inventors; and

(71) Applicants : LANGFORD, Dale [US/US]; 2612 Chaumont Terrace, Pampa, TX 79065 (US). RUDNIK, Ian, Douglas [US/US]; 1037 N. Cass Ave, Vassar, MI 48768 (US).

(74) Agents: SAUNDERS, Jason, A. et al.; Arnold, Knobloch & Saunders, L.L.P., 4900 Woodway Dr., Suite 900, Houston, TX 77056 (US).

(81) Designated States (unless otherwise indicated, for every kind of national protection available): AE, AG, AL, AM,

AO, AT, AU, AZ, BA, BB, BG, BH, BN, BR, BW, BY, BZ, CA, CH, CL, CN, CO, CR, CU, CZ, DE, DK, DM, DO, DZ, EC, EE, EG, ES, FI, GB, GD, GE, GH, GM, GT, HN, HR, HU, ID, IL, IN, IR, IS, JP, KE, KG, KN, KP, KR, KZ, LA, LC, LK, LR, LS, LU, LY, MA, MD, ME, MG, MK, MN, MW, MX, MY, MZ, NA, NG, NI, NO, NZ, OM, PA, PE, PG, PH, PL, PT, QA, RO, RS, RU, RW, SA, SC, SD, SE, SG, SK, SL, SM, ST, SV, SY, TH, TJ, TM, TN, TR, TT, TZ, UA, UG, US, UZ, VC, VN, ZA, ZM, ZW.

(84) Designated States (unless otherwise indicated, for every kind of regional protection available): ARIPO (BW, GH, GM, KE, LR, LS, MW, MZ, NA, RW, SD, SL, ST, SZ, TZ, UG, ZM, ZW), Eurasian (AM, AZ, BY, KG, KZ, RU, TJ, TM), European (AL, AT, BE, BG, CH, CY, CZ, DE, DK, EE, ES, FI, FR, GB, GR, HR, HU, IE, IS, IT, LT, LU, LV, MC, MK, MT, NL, NO, PL, PT, RO, RS, SE, SI, SK, SM, TR), OAPI (BF, BJ, CF, CG, CI, CM, GA, GN, GQ, GW, KM, ML, MR, NE, SN, TD, TG).

Declarations under Rule 4.17:

— of inventorship (Rule 4.17(iv))

Published:

— with international search report (Art. 21(3))

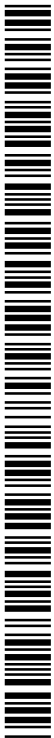

(54) Title: ALIGNMENT SYSTEM FOR A PERFORATING GUN

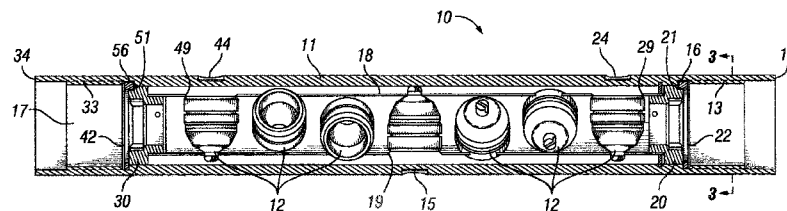

FIG. 1

(57) Abstract: An apparatus for restraining the movement of a gun charge holder within a gun tube including a snap ring with an alignment end that engages an end fitting and the gun tube simultaneously, the snap ring further comprising a grounding hole to facilitate the grounding of the electronics and detonation devices within the gun charge holder.

TITLE

[0001] Alignment System for Perforating Gun

FIELD

[0002] The invention generally relates to perforating guns used in a subterranean environment. More particularly, the invention relates using an alignment ring to accurately control the orientation of the explosive charges with respect to the perforating gun body.

BACKGROUND

[0003] Generally, when completing a subterranean well for the production of fluids, minerals, or gases from underground reservoirs, several types of tubulars are placed downhole as part of the drilling, exploration, and completions process. These tubulars can include casing, tubing, pipes, liners, and devices conveyed downhole by tubulars of various types. Each well is unique, so combinations of different tubulars may be lowered into a well for a multitude of purposes.

[0004] A subsurface or subterranean well transits one or more formations. The formation is a body of rock or strata that contains one or more compositions. The formation is treated as a continuous body. Within the formation hydrocarbon deposits may exist. Typically a wellbore will be drilled from a surface location, placing a hole into a formation of interest. Completion equipment will be put into place, including casing, tubing, and other downhole equipment as needed. Perforating the casing and the formation with a perforating gun is a well known method in the art for accessing hydrocarbon deposits within a formation from a wellbore.

[0005] Explosively perforating the formation using a shaped charge is a widely known method for completing an oil well. A shaped charge is a term of art for a device that when detonated generates a focused explosive output. This is achieved in part by the geometry of the explosive in conjunction with a liner in the explosive material. Generally, a shaped charge includes a metal case that contains an explosive material with a concave shape, which has a thin metal liner on the inner surface. Many materials are used for the liner, some of the more common metals include brass, copper, tungsten, and lead. When the explosive detonates the liner metal is compressed into a super-heated, super pressurized jet that can penetrate metal, concrete, and rock.

[0006] A perforating gun has a gun body. The gun body typically is composed of metal and is cylindrical in shape. The gun body will have one or more scallops machined out of its surface. A scallop is a thin spot on the gun body, usually circular in shape. Each scallop is designed to align with a corresponding shape charge contained within the gun body. The scallop allows for a uniform thickness of metal that is at a ninety degree angle with respect to the plasma jet that exits an exploding shape charge. The scallop allows for less explosive energy needed to exit the gun body and for a more predictable trajectory of the plasma jet into the formation being perforated. Moreover, the scallops reduce the impact burrs created during detonation that may interfere with moving the gun or retrieving the gun. However, since the shape charges are typically located on a separate charge holder located within the gun body, it is difficult to perfectly align each scallop with its corresponding shape charge.

[0007] Within a typical gun tube is a charge holder, which is a tube that is designed to hold the actual shape charges. The charge holder will contain cutouts called charge holes where the shape charges will be placed. The alignment of the charge holder with the gun tube is important in controlling the position of the shape charges when they detonate. Error in the orientation of the shape charge with respect to the scallop can cause the explosive jet to miss its intended target within the formation.

[0008] A charge tube may have end fittings attached at either end. The end fittings provide for restricting the movement of the charge tube with respect to the gun body. The current method for aligning the charge holder with the gun tube involves using an alignment end with a slot and bolt design on the gun tube. The alignment end contains a bolt head or some other protrusion. The bolt is lined up with the first shape charge. The charge holder with the alignment end is then placed inside the gun body. The gun body has a slot cut out of the inner surface. The slot is aligned with the first scallop on the gun barrel, which also happens to be the closest scallop to the alignment end. The bolt on the alignment end will normally interfere with the threads or the inner surface of the gun body if there is no slot. Thereby preventing the charge holder from being placed in the gun body. However, the slot cut will allow the charge holder to be placed into the gun body so long as the bolt head is properly aligned with the slot cut. The slot cut on the gun body is aligned with the first scallop on the outside of the gun body.

[0009] This slot and bolt design is robust and simple in its execution. The problem with this design is that the slot has to be machined through the threads. Moreover, the length of the

slot cut is limited by the machining capabilities as the slot cannot be milled into the inner gun body for more than a few inches from the end of the gun body. The bolt cannot be on the bottom of the gun charge because then the gun charge cannot be dropped into the gun tube from the top. This would require a slot machined into the side of the gun tube for the entire length of the gun tube, which is difficult and impractical. Therefore, this method cannot be used to align both ends of the charge holder with the gun tube. In some cases, such as with long perforating guns, the charges distant from the alignment end can drift out of alignment with the scallops, thereby reducing charge efficiency. Further, this method has certain manufacturing and installation limitations.

SUMMARY OF INVENTION

[0010] In a least one example of the invention, a perforating gun comprises a gun body having a bore, at least one scallop, a retaining ring groove, and a gun body alignment slot, a charge holder having at least one charge hole and a charge holder alignment slot, and a retaining ring having an alignment tab wherein the retaining ring is captured in the retaining ring groove and prevents the charge holder from translating in the bore in at least one direction and the alignment tab engages with the gun body alignment slot and the charge holder alignment slot to prevent rotation of the charge holder within the bore. One aspect to this example may include that the perforating gun has at least one scallop in the gun body wherein the engagement of the alignment tab with the gun body alignment slot and charge holder alignment slot aligns the at least one charge hole with the at least one scallop.

[0011] In variation of an example of the invention, the perforating gun further comprises a plurality of charge holes in the charge holder, and a plurality of scallops in the gun body, wherein the engagement of the alignment tab with the gun body alignment slot and charge holder alignment slot aligns the charge holes with the scallops.

[0012] In another variation of an example of the invention the perforating gun the retaining ring has a semicircular body and alignment tab is substantially orthogonal to the semicircular body. The perforating gun further comprises a grounding hole in the retaining ring.

[0013] In another example of the invention a perforating gun comprises a gun body having a bore, at least one scallop, a first retaining ring groove, a second retaining ring groove, a first gun body alignment slot, and a second gun body alignment slot, a charge holder having at least one charge hole, a first charge holder alignment slot near a first end, and a second charge holder alignment slot near a second end, a first retaining ring having an alignment tab, and a second retaining ring having an alignment tab, wherein the first retaining ring is captured in the retaining ring groove and prevents the charge holder from translating in the bore in at least one direction and the alignment tab engages with the gun body alignment slot and the charge holder alignment slot to prevent rotation of the charge holder within the bore.

[0014] In a variation of an example of the invention the perforating gun of further comprises at least one scallop in the gun body wherein the engagement of the alignment tabs with the gun body alignment slots and charge holder alignment slots aligns the at least one charge hole with the at least one scallop.

[0015] In another variation of an example of the invention the perforating gun further comprises a plurality of charge holes in the charge holder, a plurality of scallops in the gun body, wherein the engagement of the alignment tabs with the gun body alignment slots and charge holder alignment slots aligns the charge holes with the scallops. Furthermore, the perforating gun of has the retaining rings having a semicircular body and the alignment tab that is substantially orthogonal to the semicircular body. In another variation of an example of the invention the perforating gun further comprises a grounding hole in the retaining rings.

[0016] Another example of the invention is a retaining ring comprising a semicircular body, and an alignment tab, wherein the alignment tab is substantially orthogonal to the semicircular body. A variation of the retaining ring is that the retaining ring further comprises a grounding hole.

BRIEF DESCRIPTION OF THE DRAWINGS

[0017] For a thorough understating of the present invention, reference is made to the following detailed description of the preferred embodiments, taken in conjunction with the accompanying drawings in which reference numbers designate like or similar elements throughout the several figures of the drawing. Briefly:

[0018] Figure 1 is a side view of a fully assembled perforating gun.

[0019] Figure 2a and 2b are views of the snap ring.

[0020] Figure 3 is a cross sectional view of the end fitting with snap ring, installed in a gun tube.

[0021] Figure 4 is an oblique view of the fully assembled perorating gun with the snap ring installed.

DETAILED DESCRIPTION OF THE DRAWINGS

[0022] In the following description, certain terms have been used for brevity, clarity, and examples. No unnecessary limitations are to be implied therefrom and such terms are used for descriptive purposes only and are intended to be broadly construed. The different systems and method steps described herein may be used alone or in combination with other systems and method steps. It is to be expected that various equivalents, alternatives, and modifications are possible within the scope of the appended claims.

[0023] As shown in Figure 1, a typical perforating gun 10 comprises a gun body 11 that acts as a housing for all of the components necessary for containing the shape charge 12. The gun body 11 is a term of art that usually describes a cylindrical shaped tube, composed of a metal that is well known in the art. The gun body has threads 13, 33 on either end 14, 34, respectfully, that are used to assist in connecting the gun body to other tubulars, including multiple gun bodies, for use downhole. In the present embodiment these threads 13, 33 are internal. The gun body has one or more scallops 15 that are typically machined into the outside diameter of the gun body 11. A scallop 15 should align with a corresponding shape charge 12 located within the gun body 11. The scallop 15 allows the shape charge 12 to more easily penetrate the gun body 11 and facilitates a more uniform explosive jet. The scallop 15 reduces the external burrs created as the perforating jet exits the gun body 11, allowing for easier retrieval of the perforating gun 10. In this embodiment the gun body 11 has at least one gun body alignment slot 16.

[0024] The gun body alignment slot 16 may be formed by a variety of manufacturing and machining methods. The gun body alignment slot 16 may be formed by broaching a slot within the inner wall 17 of the gun body 11. The gun body alignment slot 16 may also be formed by electric discharge machining within the inner wall 17 of the gun body 11. The gun body alignment slot 16 may be formed by a combination of there or other machining operations or techniques that are known in the art.

[0025] The shape charges 12 are placed inside a charge holder 18 that contains at least one charge hole 19. Each charge hole 19, the corresponding shaped charge 12, and the corresponding scallop 15 on the gun body 11 need to all be substantially aligned in order to accurately place the holes being shot into the subterranean formation.

[0026] The charge holder 18 is connected to the gun body 11 via at least one end fitting 20, 30. The end fitting 20 and the charge holder 18 are aligned with respect to each other via

means that are well known in the art. The end fitting 20 contains the means for aligning the charge holder 18 and gun body 11. As shown in Figure 4, the charge holder 18 end fitting 20 contains a slot 21 adapted to fit a snap ring 22. The snap ring 22 prevents longitudinal movement of the charge holder 18 in the gun body 11. The first charge hole is aligned with the first scallop such that they are aligned radially.

[0027] The end fitting 20 is connected to the charge holder 18. The end fitting 20 is aligned such that the slot 16 on the end fitting 20 is aligned with the first or nearest shape charge hole 29 on the charge holder 18. The end fitting 20 is held in alignment with the charge holder 18 via a fastening means that may include a screw, a bolt, or other means that are well known in the art.

[0028] A snap ring 22 with an alignment tab 23, as shown in Figure 2A and 2B, is used to align the end fitting with respect to the gun body. As shown in Figure 3 and Figure 4, the snap ring 22 interfaces with the end fitting alignment slot 21 and matches it to the gun body alignment slot 16. The alignment tab 23 on the snap 22 ring locks in the alignment of the end fitting 20 with the first scallop 44 on the gun body 11. The snap ring 22 has a grounding hole 29 that allows for an electrical ground within perforating gun 10. This electrical ground can be used to ground electronics to the gun body 11 and the attached tool string.

[0029] In another embodiment as depicted in Fig. 1, the charge holder 18 has an end fitting 20, 30 at both ends. Each end fitting 20, 30 has an end fitting holder alignment slot 21, 51. In this embodiment, there are two retaining rings 22, 42 that are used to align the charge tube 18 within the gun body 11 at both ends. In this embodiment, the additional retaining ring 42 provides a higher degree of accurate alignment between the one or more scallops 15 of the gun body 11 and the one or more corresponding charge holes 19 on the charge holder 18. As a result, the shape charges 12 located at each charge hole 19 are more closely aligned with each corresponding scallop 15. In this embodiment, as shown in Fig. 1, the far right scallop 24 is aligned with the first gun body alignment slot 16. The far right charge hole 29 is aligned with the end fitting alignment slot 21. Furthermore, the far left scallop 44 is aligned with the second gun body alignment slot 56. The far left charge hole 49 is aligned with the second end fitting alignment slot 51.

[0030] Although the invention has been described in terms of particular embodiments which are set forth in detail, it should be understood that this is by illustration only and that the

invention is not necessarily limited thereto. Alternative embodiments and operating techniques will become apparent to those of ordinary skill in the art in view of the present disclosure. Accordingly, modifications of the invention are contemplated which may be made without departing from the spirit of the claimed invention. In particular, use of the terms “scallop”, “retaining ring groove”, “charge hole”, “charge holder alignment slot”, “retaining ring”, “alignment tab”, and “gun body alignment slot” herein and within the claims to follow are defined expansively to encompass equivalent terms that are well known in the art.

CLAIMS

1. A perforating gun comprising:
 - a gun body having a bore, at least one scallop, a retaining ring groove, and a gun body alignment slot;
 - a charge holder having at least one charge hole and a charge holder alignment slot; and
 - a retaining ring having an alignment tab;wherein the retaining ring is captured in the retaining ring groove and prevents the charge holder from translating in the bore in at least one direction and the alignment tab engages with the gun body alignment slot and the charge holder alignment slot to prevent rotation of the charge holder within the bore.
2. The perforating gun of claim 1 further comprising:
 - at least one scallop in the gun body;
 - wherein the engagement of the alignment tab with the gun body alignment slot and charge holder alignment slot aligns the at least one charge hole with the at least one scallop.
3. The perforating gun of claim 1 further comprising:
 - a plurality of charge holes in the charge holder;
 - a plurality of scallops in the gun body;
 - wherein the engagement of the alignment tab with the gun body alignment slot and charge holder alignment slot aligns the charge holes with the scallops.
4. The perforating gun of claim 1 wherein the retaining ring has a semicircular body and alignment tab is substantially orthogonal to the semicircular body.
5. The perforating gun of claim 1 further comprising a grounding hole in the retaining ring.

6. A perforating gun comprising:
 - a gun body having a bore, at least one scallop, a first retaining ring groove, a second retaining ring groove, a first gun body alignment slot, and a second gun body alignment slot;
 - a charge holder having at least one charge hole, a first charge holder alignment slot near a first end, and a second charge holder alignment slot near a second end;
 - a first retaining ring having an alignment tab; and
 - a second retaining ring having an alignment tab;wherein the first retaining ring is captured in the retaining ring groove and prevents the charge holder from translating in the bore in at least one direction and the alignment tab engages with the gun body alignment slot and the charge holder alignment slot to prevent rotation of the charge holder within the bore.
7. The perforating gun of claim 7 further comprising:
 - at least one scallop in the gun body;wherein the engagement of the alignment tabs with the gun body alignment slots and charge holder alignment slots aligns the at least one charge hole with the at least one scallop.
8. The perforating gun of claim 7 further comprising:
 - a plurality of charge holes in the charge holder;
 - a plurality of scallops in the gun body;wherein the engagement of the alignment tabs with the gun body alignment slots and charge holder alignment slots aligns the charge holes with the scallops.
9. The perforating gun of claim 7 wherein the retaining rings have a semicircular body and the alignment tab is substantially orthogonal to the semicircular body.
10. The perforating gun of claim 7 further comprising a grounding hole in the retaining rings.

11. A retaining ring comprising:
 - a semicircular body;
 - an alignment tab;
 - wherein the alignment tab is substantially orthogonal to the semicircular body.
12. The retaining ring of claim 11 further comprising:
 - a grounding hole.

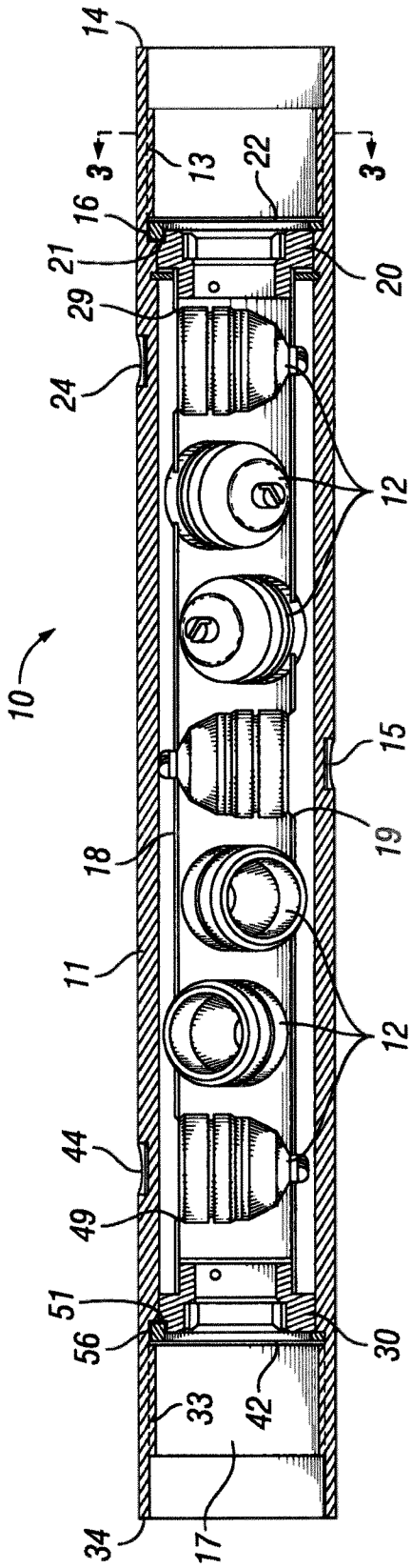

1/2

FIG. 1

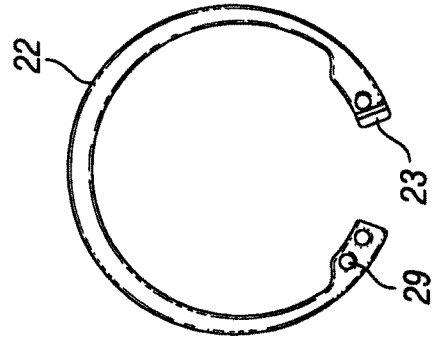

FIG. 2B

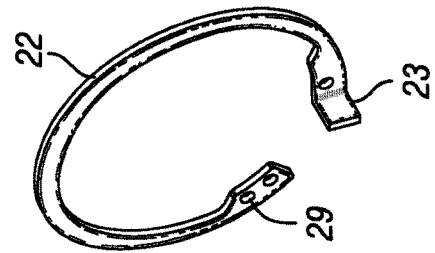

FIG. 2A

2/2

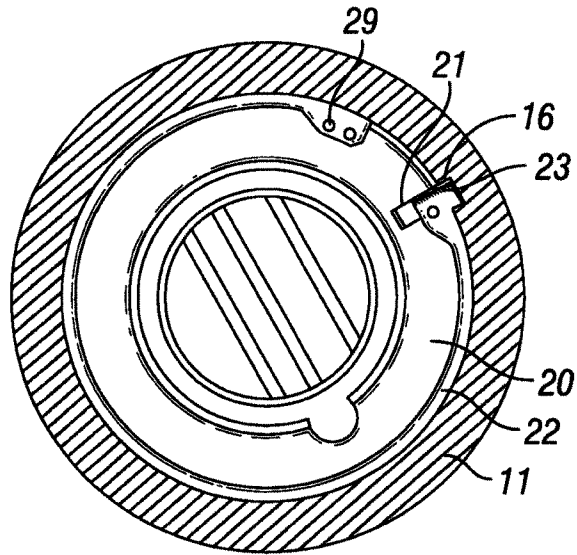

FIG. 3

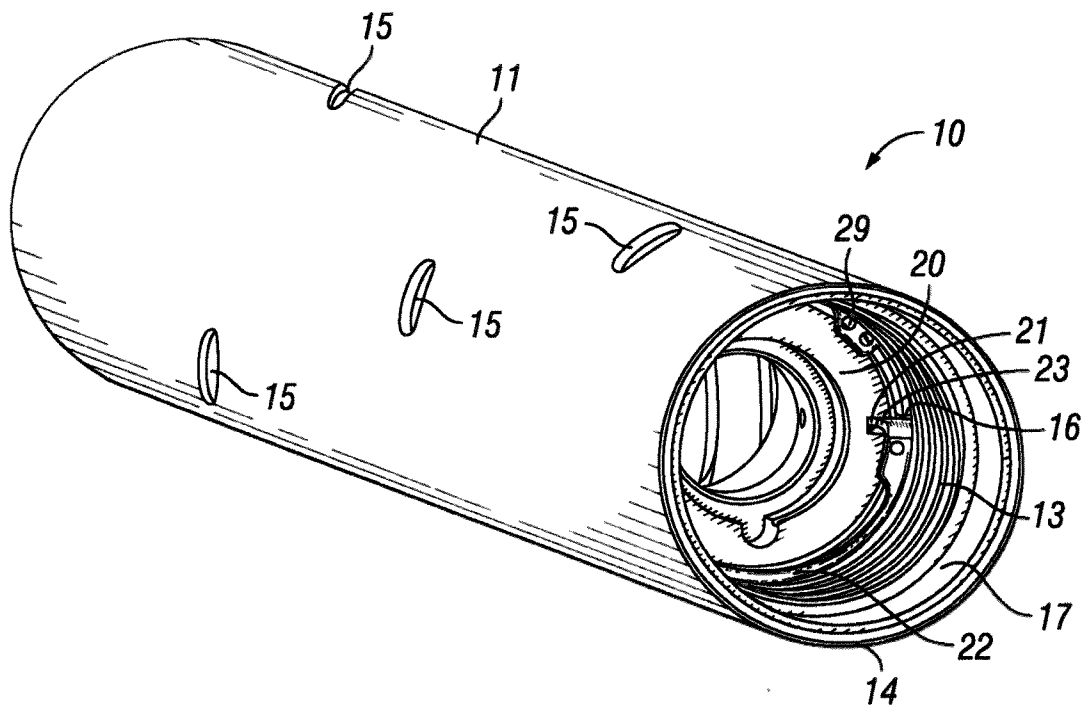

FIG. 4

INTERNATIONAL SEARCH REPORT

International application No.

PCT/US2014/059894

A. CLASSIFICATION OF SUBJECT MATTER

IPC(8) - E21B 43/117 (2014.01)

CPC - E21B 43/117 (2014.12)

According to International Patent Classification (IPC) or to both national classification and IPC

B. FIELDS SEARCHED

Minimum documentation searched (classification system followed by classification symbols)

IPC(8) - E21B 43/11, 43/117, 43/118, 43/119 (2014.01)

CPC - E21B 43/11, 43/117, 43/118, 43/119 (2014.12)

Documentation searched other than minimum documentation to the extent that such documents are included in the fields searched

USPC - 89/1; 102/313; 166/55, 55.1, 63; 175/4.6 (keyword delimited)

Electronic data base consulted during the international search (name of data base and, where practicable, search terms used)

Orbit, Google Patents, Google.

Search terms used: scallop, retaining ring, groove, semicircular, charge, device, hole, holder, alignment, slot, snap ring, alignment, rotate, alignment slot, perforating gun, position, shaped charge, perforating, align, position, carrier, gun, end cap, aligned, cylinder, case

C. DOCUMENTS CONSIDERED TO BE RELEVANT

Category*	Citation of document, with indication, where appropriate, of the relevant passages	Relevant to claim No.
X	US 6,352,439 B1 (STARK et al) 05 March 2002 (05.03.2002) entire document	11-12
Y	US 6,851,471 B2 (BARLOW et al) 08 February 2005 (08.02.2005) entire document	1-10
Y	US 4,583,602 A (AYERS) 22 April 1986 (22.04.1986) entire document	1-10
A	US 7,762,351 B2 (VIDAL) 27 July 2010 (27.07.2010) entire document	1-12
A	US 7,000,699 B2 (YANG et al) 21 February 2006 (21.02.2006) entire document	1-12
A	US 4,753,301 A (BERRY) 28 June 1988 (28.06.1988) entire document	1-12

Further documents are listed in the continuation of Box C.

* Special categories of cited documents:

"A" document defining the general state of the art which is not considered to be of particular relevance

"E" earlier application or patent but published on or after the international filing date

"L" document which may throw doubts on priority claim(s) or which is cited to establish the publication date of another citation or other special reason (as specified)

"O" document referring to an oral disclosure, use, exhibition or other means

"P" document published prior to the international filing date but later than the priority date claimed

"T" later document published after the international filing date or priority date and not in conflict with the application but cited to understand the principle or theory underlying the invention

"X" document of particular relevance; the claimed invention cannot be considered novel or cannot be considered to involve an inventive step when the document is taken alone

"Y" document of particular relevance; the claimed invention cannot be considered to involve an inventive step when the document is combined with one or more other such documents, such combination being obvious to a person skilled in the art

"&" document member of the same patent family

Date of the actual completion of the international search

23 December 2014

Date of mailing of the international search report

10 FEB 2015

Name and mailing address of the ISA/US

Mail Stop PCT, Attn: ISA/US, Commissioner for Patents
P.O. Box 1450, Alexandria, Virginia 22313-1450

Facsimile No. 571-273-3201

Authorized officer:

Blaine R. Copenheaver

PCT Helpdesk: 571-272-4300

PCT OSP: 571-272-7774