



(51) International Patent Classification:

**B65B 5/10** (2006.01)      **B65B 35/50** (2006.01)  
**B65B 35/18** (2006.01)      **B65B 35/54** (2006.01)

(21) International Application Number:

PCT/IB20 14/06 1333

(22) International Filing Date:

9 May 2014 (09.05.2014)

(25) Filing Language:

Italian

(26) Publication Language:

English

(30) Priority Data:

MI2013A000762      9 May 2013 (09.05.2013)      IT

(71) Applicant: **I.M.A. INDUSTRIA MACCHINE AUTOMATICHE S.P.A.** [IT/IT]; Via Emilia, 428/442, 1-40064 Ozzano Dell'Emilia (IT).

(72) Inventor: **FONTANA, Alessio**; Via Mameli, 56, 1-48014 Castel Bolognese (IT).

(74) Agents: **PETRAZ, Davide Luigi** et al; GLP SRL, Viale Europa Unità, 171, 1-33 100 Udine (IT).

(81) Designated States (unless otherwise indicated, for every kind of national protection available): AE, AG, AL, AM, AO, AT, AU, AZ, BA, BB, BG, BH, BN, BR, BW, BY,

BZ, CA, CH, CL, CN, CO, CR, CU, CZ, DE, DK, DM, DO, DZ, EC, EE, EG, ES, FI, GB, GD, GE, GH, GM, GT, HN, HR, HU, ID, IL, IN, IR, IS, JP, KE, KG, KN, KP, KR, KZ, LA, LC, LK, LR, LS, LT, LU, LY, MA, MD, ME, MG, MK, MN, MW, MX, MY, MZ, NA, NG, NI, NO, NZ, OM, PA, PE, PG, PH, PL, PT, QA, RO, RS, RU, RW, SA, SC, SD, SE, SG, SK, SL, SM, ST, SV, SY, TH, TJ, TM, TN, TR, TT, TZ, UA, UG, US, UZ, VC, VN, ZA, ZM, ZW.

(84) Designated States (unless otherwise indicated, for every kind of regional protection available): ARIPO (BW, GH, GM, KE, LR, LS, MW, MZ, NA, RW, SD, SL, SZ, TZ, UG, ZM, ZW), Eurasian (AM, AZ, BY, KG, KZ, RU, TJ, TM), European (AL, AT, BE, BG, CH, CY, CZ, DE, DK, EE, ES, FI, FR, GB, GR, HR, HU, IE, IS, IT, LT, LU, LV, MC, MK, MT, NL, NO, PL, PT, RO, RS, SE, SI, SK, SM, TR), OAPI (BF, BJ, CF, CG, CI, CM, GA, GN, GQ, GW, KM, ML, MR, NE, SN, TD, TG).

Published:

- with international search report (Art. 21(3))
- before the expiration of the time limit for amending the claims and to be republished in the event of receipt of amendments (Rule 48.2(h))

(54) Title: PLANT AND METHOD FOR PACKAGING BLISTERS

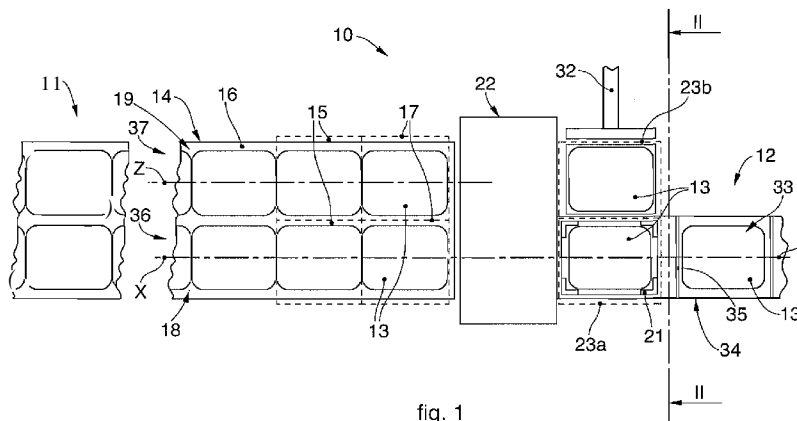

(57) Abstract: Plant for packaging blisters (13) comprising a blistering machine (11) and a packaging machine (12). At least two lines of transport (36, 37) of blisters (13) are disposed between the blistering machine (11) and the packaging machine (12), define respective axes of work (X, Z) parallel to each other and end in cooperation with a transfer means (22) that feeds at least a first delivery zone (23 a) and at least a second delivery zone (23b) downstream of the two lines of transport (36, 37) and each is suitable to receive one blister (13) on each occasion. The first delivery zone (23a) is the only one configured to feed the packaging machine (12) and the at least one second delivery zone (23b) cooperates with a positioning device (32) suitable to transfer the blisters (13) from the second delivery zone (23b) to the first delivery zone (23a).



## "PLANT AND METHOD FOR PACKAGING BLISTERS"

\* \* \* \* \*

### FIELD OF THE INVENTION

The present invention concerns a plant for packaging blisters. In particular, the present invention concerns a packaging plant which, contrary to the state of the art, develops linearly even in the case when machines are grouped together and combined. The present invention also concerns the corresponding method for packaging blisters.

### BACKGROUND OF THE INVENTION

10 Packaging plants for blisters are known, that is, the casings that contain and protect capsules, tablets or suchlike.

Said packaging plants comprise a boxing or packaging machine, disposed immediately downstream of a blister producing machine, or blistering machine. Said plants can be obtained either with coupled machines or integrated machines.

15 In order to meet the requirements of combining, controlling and positioning the blisters in the packaging machine, between the latter and the blistering machine, in the combined machines, there have always been diverted paths, or diversions, before the blisters are made to arrive in the final containing case or box. Normally the blisters are delivered to storage containers and from these are then introduced into the boxes in the desired number. An example of the connection between the packaging machine and the blistering machine is described in document WO 2009/141283.

20 Said diversions not only complicate the structure and functionality of the machines, but also need a complex set-up and greater maintenance, they increase energy consumption and are bulky since they take up a lot of space at the front, because of the diversions. Moreover, such a configuration of the machine requires the presence of intermediate stores in order to compensate for any discarded blisters.

30 A packaging plant is also known from document US-B-6.347.709, which comprises a blistering machine and a packaging machine operating on a plurality of rows of blisters, on each occasion, made by the blistering machine. In this solution both the blistering machine and the packaging machine are designed to have the same number of blister work lines.

This entails using packaging machines with an oversized number of work lines compared to their actual productive capacity, and constrained by the number of work lines needed for the blistering machine. Purposes of the present invention are to simplify the setting up step, reduce maintenance interventions, energy  
5 consumption and the overall bulk of the plant with the added advantage of lower running and management costs.

Another purpose of the present invention is to simplify the control of the work cycle by the operators so they can also intervene more quickly in cases of blockages, given that the plant is disposed on a single front.

10 It is also a purpose of the present invention to simplify the construction and management of a packaging plant.

The Applicant has devised, tested and embodied the present invention to overcome the shortcomings of the state of the art and to obtain these and other purposes and advantages.

#### 15 SUMMARY OF THE INVENTION

The present invention is set forth and characterized in the independent claims, while the dependent claims describe other characteristics of the invention or variants to the main inventive idea.

In accordance with the above purposes, a plant for packaging blisters  
20 comprises a blistering machine configured to make blisters in two or more rows located parallel to each other.

According to the invention, the rows are obtained either from a single strip or from independent strips.

25 Hereafter, to simplify the description, we will illustrate the case where rows of blisters are obtained from a single strip; however, it is understood that the present invention also includes the case where the individual rows of blisters are obtained from individual strips.

The plant also comprises a packaging machine disposed downstream of the blistering machine, and which allows to introduce the blisters in packaging boxes  
30 for their subsequent introduction onto the market.

Between the blistering machine and the packaging machine at least two blister transport lines are disposed, which respectively define axes of work which are parallel to each other. The blister transport lines end in cooperation with a blister

transfer mean that feeds at least one first delivery zone and one second delivery zone located downstream of the two lines of transport.

Both the first delivery zone and the second delivery zone are suitable to receive one blister from the transfer mean on each occasion.

5 The first delivery zone is the only one that cooperates with the packaging machine while the second delivery zone cooperates with a positioning device suitable to transfer the blisters from the second delivery zone to the first delivery zone.

10 In this way the packaging machine is able to pack, along a single axis of work, all the blisters produced in different rows in the blistering machine and transferred by means of the lines of transport.

The present invention also concerns an embodiment of the plant that provides a blistering machine able to operate on three parallel rows of blisters and also comprises a third line of transport for the third row of blisters.

15 The third line of transport is disposed adjacent to one of the two lines of transport, defines a respective third axis of work parallel to the axes of work and ends in cooperation with the transfer mean. Moreover, downstream of the lines of transport the plant comprises a third delivery zone cooperating with a respective positioning device suitable to transfer the blisters from the third delivery zone to  
20 the first delivery zone.

#### BRIEF DESCRIPTION OF THE DRAWINGS

These and other characteristics of the present invention will become apparent from the following description of some forms of embodiment, given as a non-restrictive example with reference to the attached drawings wherein:

- 25 - fig. 1 is a schematic representation of a plant for packaging blisters according to the present invention;
- fig. 2a is a schematic representation of the plant of fig. 1 seen in section from II to II in fig. 1;
- fig. 2b is a schematic representation of a possible variant of fig. 2a;
- 30 - fig. 3 is a schematic representation of a plant for packaging blisters according to a variant of fig. 1;
- fig. 4 is a schematic representation of the plant in fig. 3 seen in section from IV to IV in fig. 3;

- fig. 5 is a schematic representation of a possible transfer mean provided in the packaging plant according to the present invention, in a first work condition;
- fig. 6 is a schematic representation of the transfer mean in fig. 5, in a second work condition;
- 5 - fig. 7 is a schematic representation of a transfer mean in accordance with a variant of figs. 5 and 6.

To facilitate comprehension, the same reference numbers have been used, where possible, to identify identical common elements in the drawings. It is understood that elements and characteristics of one form of embodiment can  
10 conveniently be incorporated into other forms of embodiment without further clarifications.

#### DETAILED DESCRIPTION OF SOME FORMS OF EMBODIMENT

With reference to fig. 1 a plant for packaging is indicated in its entirety by the reference number 10 and comprises a blistering machine 11 and a packaging  
15 machine 12.

Between the blistering machine 11 and the packaging machine 12 a line of work 14 is interposed in which a strip 16, after having been worked to obtain the blisters 13, is made to advance toward the packaging machine 12.

The line of work 14 comprises at least two lines of transport, respectively a  
20 first line of transport 36 and a second line of transport 37 defining two respective axes of work, respectively a first axis of work X and a second axis of work Z.

The first axis of work X and the second axis of work Z are located adjacent and parallel to each other and end in cooperation with a transfer mean 22.

The first line of transport 36 and the second line of transport 37 can be  
25 configured to work at least two rows of blisters 13, respectively a first row 18 and a second row 19 of blisters 13 which are parallel and adjacent.

In the form of embodiment in fig. 3, the line of work 14 is configured to work three parallel and simultaneous rows of blisters 13 simultaneously, that is, the first row 18, the second row 19 and a further third row 20. In this form of  
30 embodiment it is provided that the line of work 14 comprises a third line of transport 38 disposed adjacent to one of the other two lines of transport 36 and 37, in this case adjacent to the first line of transport 36.

In particular, the first line of transport 36 is intermediate between the second

line of transport 37 and the third line of transport 38.

The third line of transport 38 defines a third axis of work W located substantially parallel to the first axis of work X and to the second axis of work Z.

5 The first row 18, the second row 19 and the third row 20 comprise at least a separation zone 15 for separating the blisters 13 from the strip 16, and possibly, a waste zone in which the blisters 13 which are to be discarded are disposed.

10 Downstream of the separation zone 15, or in conjunction with it, a pick-up zone 17 is provided to pick up the blisters 13, advantageously a pick-up zone for each row 18, 19, 20 from which the blisters 13 are picked up to be subsequently transferred to the packaging machine 12.

15 With reference to the form of embodiment shown in fig. 1, the transport mean 22, of a known type, is suitable to move the blisters 13 from the pick-up zone 17 toward at least two delivery zones, in this case a first delivery zone 23a and a second delivery zone 23b disposed downstream of the first line of transport 36 and of the second line of transport 37. The first delivery zone 23a and the second delivery zone 23b are suitable to receive one blister 13 on each occasion.

According to one form of embodiment, the first delivery zone 23a is the only one that cooperates with the packaging machine 12, that is, it is the only one configured to feed the packaging machine 12.

20 The second delivery zone 23b cooperates with a positioning device 32 suitable to transfer the blisters 13 from the second delivery zone 23b to the first delivery zone 23a. In this way, both the blisters 13 transported by the first line of transport 36 and also those transported by the second line of transport 37 are positioned in the first delivery zone 23a to be subsequently fed to the packaging machine 12.

25 In the form of embodiment in figs. 1 and 2a and 2b, the first delivery zone 23a is in line with the first axis of work X and the second delivery zone 23b is laterally adjacent to the first delivery zone 23a and, in this case, aligned to the second axis of work Z.

30 In the form of embodiment in figs. 3 and 4, as well as the first delivery zone 23a and the second delivery zone 23b, a third delivery zone 23c is provided, adjacent to the first delivery zone 23a and, in this case, aligned with the third axis of work W.

In the forms of embodiment shown in figs. 1-4, the first delivery zone 23a

cooperates with a store 21 in which the transfer mean 22 directly disposes the blisters 13. The store 21 is configured to contain at least temporarily a plurality of blisters 13 coming from the lines of transport 36, 37 and, if present, from the third line of transport 38.

5 The store 21 is configured to prepare organized piles 33 of a defined number of blisters 13 to be subsequently introduced into a respective box.

The store 21 also has the function of compensating for discarded blisters 13 that can occur after the operations in the blistering machine 11.

10 According to one possible solution, shown for example in fig. 2a, the store 21 comprises a counter device 39 configured to count the number of blisters 13 contained, on each occasion, in the store 21 and delivery devices 40 configured to deliver a predefined number of blisters 13 toward the packaging machine 12.

The counter device 39 is also configured to count the number of blisters 13 which are delivered to the packaging machine 12 on each occasion.

15 The counter device 39 can also be configured to support the blisters 13 which, on each occasion, are positioned in the store 21 and can be configured to release one or more blisters 13 in a programmed way toward the delivery device 40.

20 According to possible alternative solutions, the first delivery zone 23a can cooperate with a container that temporarily contains blisters 13 before they are introduced into cases. In some forms of embodiment of the present invention, not shown in the drawings, the container can directly comprise the case in which the blisters 13 are disposed, for their subsequent distribution on the market. For example, with reference to fig. 2b, the first delivery zone 23a can be located in correspondence to the packaging machine 12 and the blisters 13 in the store 21 are discharged, individually or in groups, to the packaging machine 12.

25 With reference to figs. 1-6 a possible transfer mean 22 is described, provided to transfer the blisters 13 from the pick-up zones 17 toward the delivery zones 23a, 23b and/or 23c.

30 The transfer mean 22 is configured to simultaneously pick up the blisters 13 from each of the pick-up zones 17 and to deliver them to the corresponding delivery zone 23a, 23b and/or 23c of the packaging machine 12 as shown in figs. 2 and 4.

According to the invention the transfer mean 22 is of the known type and can

be the rotating, linear, closed chain, pantograph type or suchlike, since the transfer mean 22 is part of the invention as it is, and not because of how it is made geometrically.

Moreover, for simplicity of explanation it is provided that the transfer mean  
5 22 picks up and delivers a single blister 13 at a time from each row 18, 19 or 20 even if multiple transfer is in the spirit of the invention.

The transfer mean 22 (figs. 5 and 6) in this case comprises two gripping and holding devices 24a and respectively 24b, to grip and hold the blisters 13, each of them associated to one of the ends of a support arm 25.

10 The transfer mean 22 also comprises a handle 26 selectively rotatable around a first end 27. A second end 28 of the handle 26, opposite the first end 27, is pivoted on a pin 29 attached to the center line of the support arm 25.

The transfer mean 22 is provided with a temporary blister positioning station 30, or intermediate buffer, which is interposed between the pick-up zone 17 and  
15 the first delivery zone 23a and the second and third delivery zone 23b, 23c. In particular, the temporary positioning station 30 is associated with devices 41 to control and select the blisters 13 aforementioned. In particular, the control and selection devices 41 are configured to control and possibly discard any blisters 13 which are empty or incomplete.

20 The rotation of the handle 26 in one direction of rotation determines a first transfer of the blisters 13 from the pick-up zones 17 toward the temporary positioning station 30 carried out by the gripping and holding device 24a and a simultaneous second transfer of the blisters 13 from the temporary positioning station 30 toward the first delivery zone 23a and the second and third delivery  
25 zone 23b and 23c carried out by the gripping and holding device 24b. The rotation of the handle 26 in an opposite direction returns the transfer mean 22 into the initial condition in order to pick up more blisters 13 from the pick-up zones 17.

Other forms of embodiment, for example the one shown in fig. 7, can provide  
30 that the transfer mean 22 comprises a single gripping and holding device 124.

In this form of embodiment the transfer mean 22 comprises a rotatable handle 126 provided at one end with a support arm 125 to which the gripping and holding device 124 of the blisters 13 is associated.

The transfer mean 22 described above with reference to figs. 1-7 is configured so that the blisters 13 taken from the first row 18 are put directly into the store 21, whereas the blisters 13 taken from the second row 19 and/or from the third row 20 are instead located laterally to the store 21 on respective support planes 31 to be subsequently introduced into the store 21 as shown in figs. 2 and 4.

The support planes 31 (figs. 2 and 4) of the second delivery zone 23b and the third delivery zone 23c are disposed above, or substantially flush with the aperture through which the blisters 13 are inserted into the store 21.

The second delivery zone 23b and the third delivery zone 23c comprise respective positioning devices 32 configured to move the blisters 13 present on the support planes 31 in a direction transverse to the first axis of work X and introduce them into the store 21 provided in the first delivery zone 23a.

In this case, the positioning device 32 is provided to move the blisters 13 in a direction orthogonal to the first axis of work X.

The positioning devices 32 according to the invention can comprise linear actuators, rotating actuators, kinematic mechanisms, thruster members or possible combinations thereof.

In the form of embodiment shown in figs. 1-4 the positioning devices 32 comprise an actuator provided with a terminal end suitable to thrust the blisters 13 that are disposed on the support planes 31 into the store 21.

Once the blisters 13 are put in the store 21, the latter disposes said organized piles 33 of blisters 13 for subsequent boxing or packaging.

Some forms of embodiment, for example those shown in figs. 1, 3, 5, 6 and 7, provide that said organized piles 33 are located in a tray 35 configured to contain a predefined number of blisters 13 which will subsequently be introduced into the containing box for subsequent introduction onto the market.

For this purpose between the first delivery zone 23a and the packaging machine 12 a feed mean 34 can be present (figs. 1, 2a, 3, 4, 5, 6, 7) located aligned to an axis of feed T of the blisters 13 and configured to feed the blisters 13 present in the first delivery zone 23a to the packaging machine 12.

The axis of feed T is located parallel to said axes of work X, Z and W.

In accordance with one solution, the axis of feed T is disposed aligned with one of the axes of work, in this case with the first axis of work X.

The feed mean 34 can comprise conveyor belts or similar means suitable to transfer the organized piles 33, or the individual blisters 13, inside the packaging machine 12. The trays 35 can be associated to the feed mean 34 which provides to transfer the blisters 13 contained in the trays 35 inside the packaging machine  
5 12.

The present invention also concerns a method to package blisters 13 as described above, which comprises a step of producing, in the blistering machine 11, at least two rows 18, 19 of blisters 13, a step of packaging the blisters 13 in a packaging machine 12 and a step of transferring the blisters 13 from the  
10 blistering machine 11 to the packaging machine 12.

According to one possible solution, the transfer step comprises an operation of transporting the blisters 13 along at least said two lines of transport 36, 37 of the blisters 13 and an operation with the transport mean 22 of transferring the blisters 13 from the two lines of transport 36, 37 to the first delivery zone 23a and to the  
15 second delivery zone 23b.

The first delivery zone 23a is the only one that cooperates with the packaging machine 12, and a transfer of the blisters 13 is provided from the second delivery zone 23b to the first delivery zone 23a.

According to one possible implementation, the method provides that during  
20 the operation of transferring the blisters 13 with the transfer mean 22, a temporary positioning of the blisters 13 is also provided in the temporary positioning station 30 before their eventual transfer into the first delivery zone 23a and into the second delivery zone 23b.

According to one possible solution, the method can provide that during the  
25 production step also the production is provided of a third row 20 of blisters 13 adjacent to the other two rows 18, 19.

In this solution, the third row 20 is transported along a third line of transport 38, the blisters 13 of the third row 20 are transferred from the third line of transport 38 to the third delivery zone 23c, and the blisters 13 present in the third  
30 delivery zone 23c are positioned in the first delivery zone 23a.

It is clear that modifications and/or additions of parts may be made to the packaging plant 10 and method as described heretofore, without departing from the field and scope of the present invention.

- 10 -

It is also clear that, although the present invention has been described with reference to some specific examples, a person of skill in the art shall certainly be able to achieve many other equivalent forms of packaging plant 10 and method, having the characteristics as set forth in the claims and hence all coming within  
5 the field of protection defined thereby.

## CLAIMS

1. Plant for packaging blisters (13) comprising a blistering machine (11) and a packaging machine (12), at least two lines of transport (36, 37) of said blisters (13) being disposed between the blistering machine (11) and the packaging machine (12), defining respective axes of work (X, Z) parallel to each other and ending in cooperation with a transfer mean (22) that feeds at least a first delivery zone (23a) and at least a second delivery zone (23b) downstream of the two lines of transport (36, 37) and each being suitable to receive one blister (13) on each occasion, the first delivery zone (23a) being the only one configured to feed the packaging machine (12) and the at least one second delivery zone (23b) cooperating with a positioning device (32) suitable to transfer the blisters (13) from said second delivery zone (23b) to said first delivery zone (23a).
2. Plant as in claim 1, **characterized in that** said transfer mean (22) comprises a temporary positioning station (30) for said blisters (13), configured to temporarily contain said blisters (13) before their eventual transfer into said first delivery zone (23a) and into said at least one second delivery zone (23b).
3. Plant as in claim 2, **characterized in that** said temporary positioning station (30) is served by control and selection devices (41) of said blisters (13).
4. Plant as in any claim hereinbefore, **characterized in that** the first delivery zone (23a) is configured to directly feed the packaging machine (12), supplying one blister (13) at a time.
5. Plant as in any claim from 1 to 3, **characterized in that** said first delivery zone (23a) cooperates with a store (21) configured to at least temporarily contain a plurality of blisters (13) coming from said lines of transport (36, 37).
6. Plant as in claim 5, **characterized in that** said store (21) comprises a counter device (39) configured to count the number of blisters (13) contained on each occasion in said store (21), and delivery devices (40) configured to deliver a predefined number of blisters (13) toward said packaging machine (12).
7. Plant as in any claim hereinbefore, **characterized in that** between the first delivery zone (23a) and the packaging machine (12) there is a feed mean (34) with an axis of feed (T) of said blisters (13) parallel to the axes of work (X, Z), said feed mean (34) being configured to feed the blisters (13) present in said first delivery zone (23a) to said packaging machine (12).

8. Plant as in claim 7, **characterized in that** said axis of feed (T) is disposed aligned with one of said axes of work (X, Z).

9. Plant as in claims 5 or 6, and 7 or 8, **characterized in that** said feed mean (34) is configured to receive the blisters (13) from said store (21).

5 10. Plant as in any claim hereinbefore, **characterized in that** said first delivery zone (23a) and said second delivery zone (23b) are each aligned along one of said axes of work (X, Z).

11. Plant as in any claim hereinbefore, **characterized in that** said positioning device (32) is configured to move said blisters (13) in a direction transverse to  
10 said axes of work (X, Z).

12. Plant as in any claim hereinbefore, **characterized in that** it comprises at least a third line of transport (38) disposed adjacent to one of said two lines of transport (36, 37), defining a respective third axis of work (W) parallel to said axes of work (X,Z) and ending in cooperation with said transfer mean (22), **and**  
15 **in that** it comprises, downstream of said lines of transport (36, 37), a third delivery zone (23c) cooperating with a respective positioning device (32) suitable to transfer the blisters (13) from said third delivery zone (23c) to said first delivery zone (23a).

13. Plant as in claim 11, **characterized in that** said first delivery zone (23a) is  
20 interposed between said second delivery zone (23b) and said third delivery zone (23c).

14. Method for packaging blisters (13) comprising a step of producing, in a blistering machine (11), at least two rows (18, 19) of blisters (13) defining respective axes of work (X, Z), parallel to each other, a step of packaging said  
25 blisters (13) in a packaging machine (12) and a step of transferring said blisters (13) from said blistering machine (11) to said packaging machine (12), said transfer step comprising an operation of transporting said blisters (13) along at least two lines of transport (36, 37) of blisters (13) disposed between the blistering machine (11) and the packaging machine (12), an operation of  
30 transferring said blisters (13) with a transfer mean (22) from said two lines of transport (36, 37) to a first delivery zone (23a) and to at least one second delivery zone (23b) disposed downstream of said two lines of transport (36, 37), said first delivery zone (23a) being the only one which feeds said packaging machine (12),

and a transfer of the blisters (13) being provided from said at least one second delivery zone (23b) to said first delivery zone (23a).

15. Method as in claim 14, **characterized in that** said transfer operation with said transfer mean (22) provides a temporary positioning of said blisters (13) in a  
5 temporary positioning station (30) before their eventual transfer into said first delivery zone (23a) and said at least one second delivery zone (23b).

16. Method as in claim 15, **characterized in that** during said temporary positioning in said temporary positioning station (30) a control and selection of at least some of said blisters (13) is provided.

10 17. Method as in any of the claims from 14 to 16, **characterized in that** it provides to feed said packaging machine (12) with the blisters (13) present in said first delivery zone (23a) by means of a feed mean (34) with an axis of feed (T) of said blisters (13) parallel to the axes of work (X, Z).

15 18. Method as in any of the claims from 14 to 17, **characterized in that** said production step provides to produce a third row (20) of blisters (13) adjacent to said two rows (18, 19) and defining a respective third axis of work (W) parallel to said axes of work (X, Z), **and in that** it provides to transport said third row (20) along a third line of transport (38), to transfer the blisters of said third row (20) from said third line of transport (38) to a third delivery zone (23c) and to position  
20 the blisters (13) present in said third delivery zone (23c) in said first delivery zone (23a).

1/4

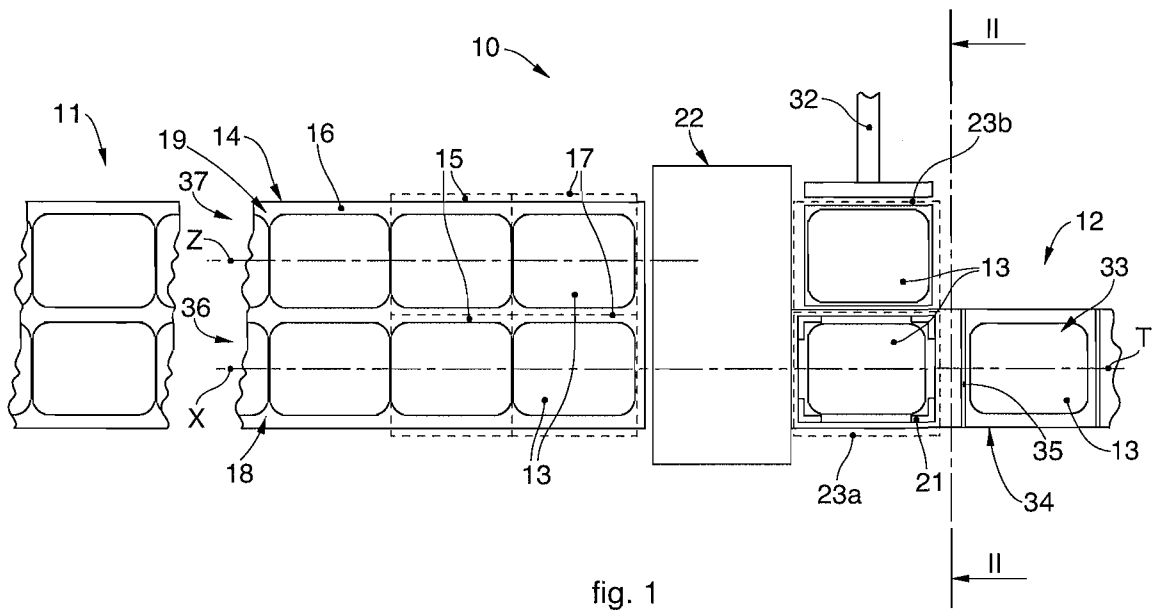

fig. 1

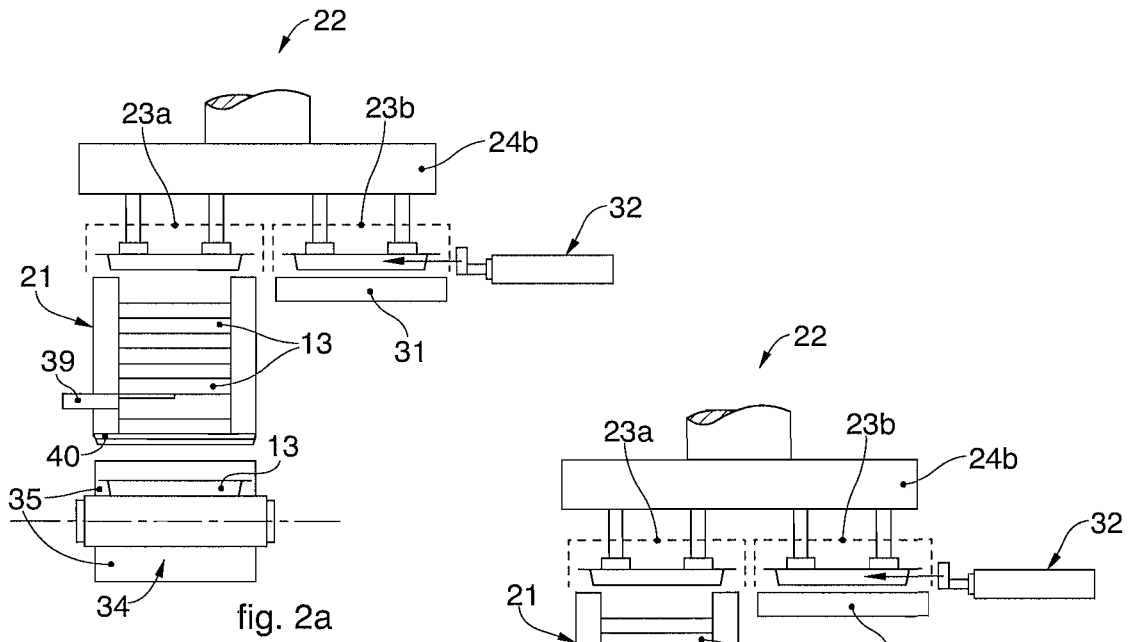

fig. 2a

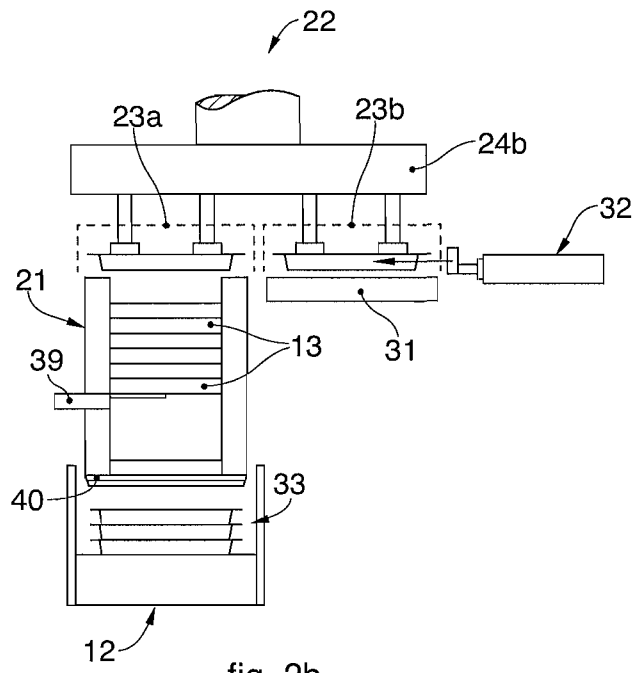

fig. 2b

2/4

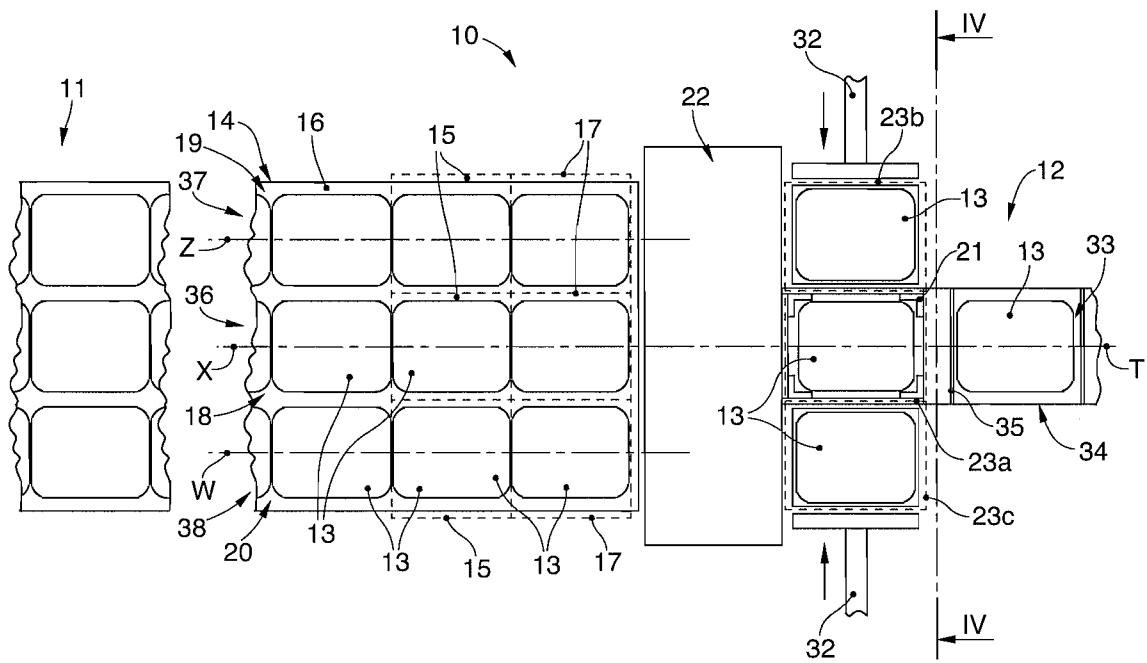

fig. 3

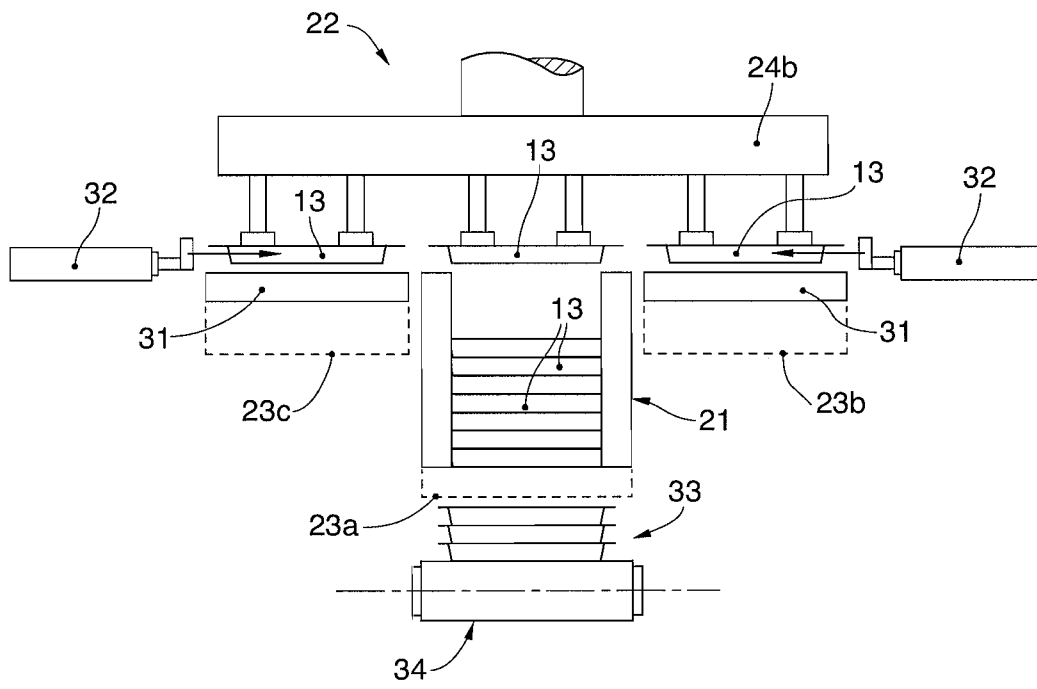

fig. 4

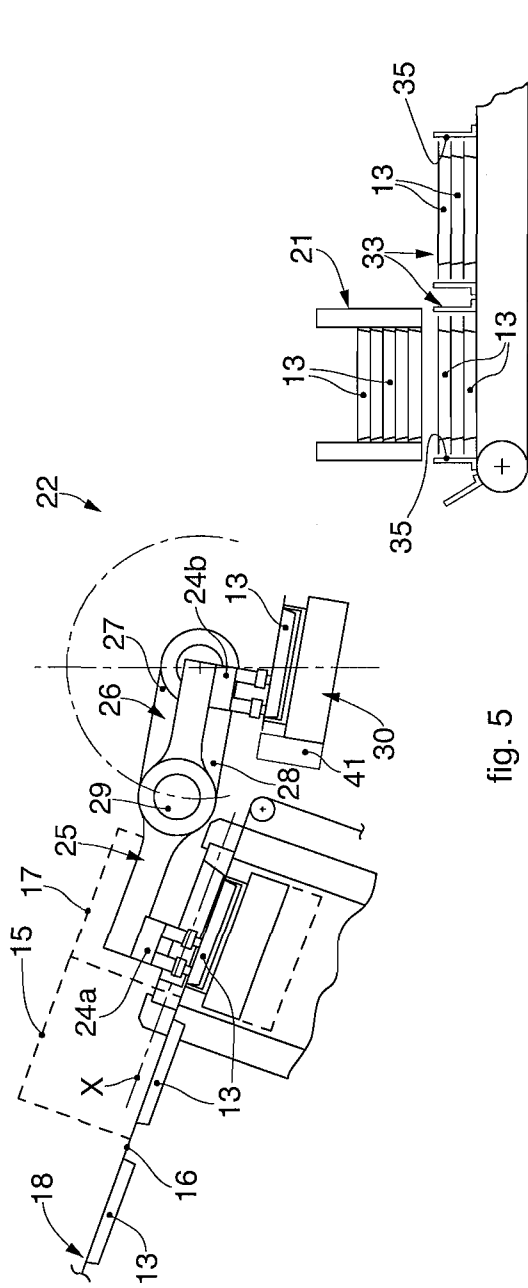

fig. 5

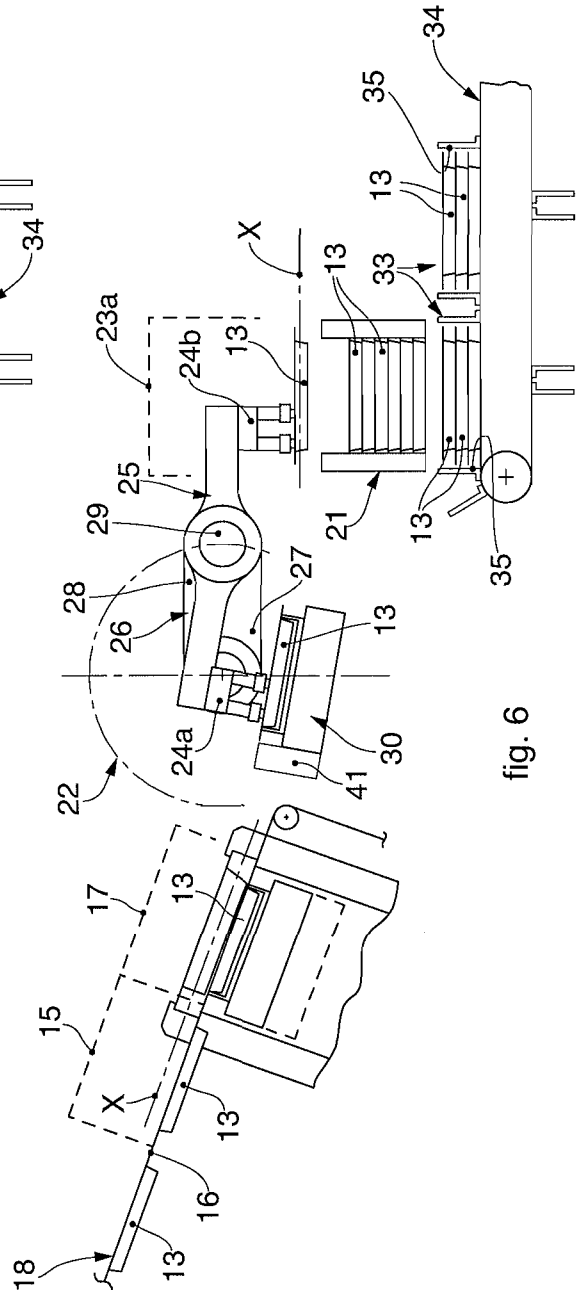

fig. 6

4/4

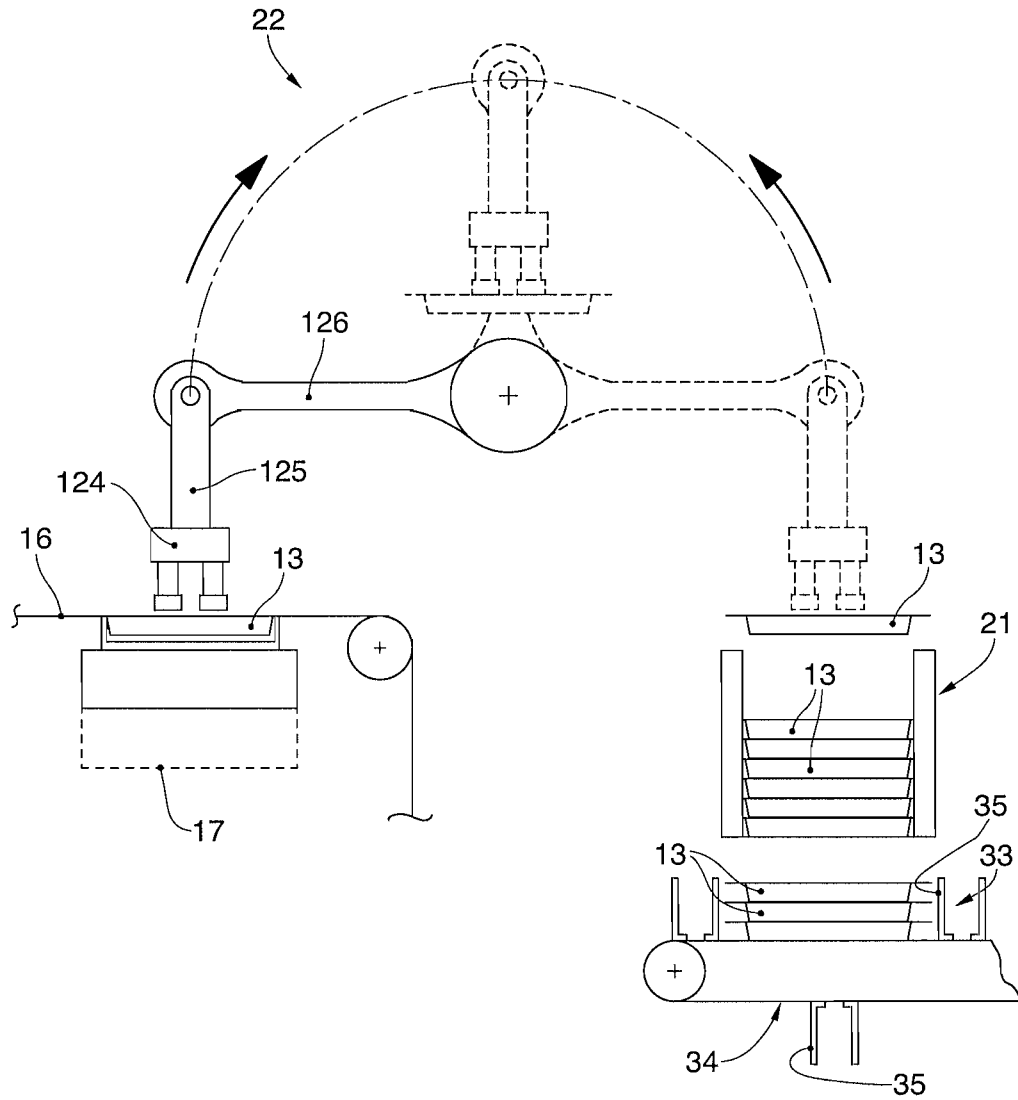

fig. 7

**INTERNATIONAL SEARCH REPORT**

International application No

PCT/IB2014/061333

A. CLASSIFICATION OF SUBJECT MATTER  
 INV. B65B5/10 B65B35/18 B65B35/50 B65B35/54  
 ADD.

According to International Patent Classification (IPC) or to both national classification and IPC

**B. FIELDS SEARCHED**

Minimum documentation searched (classification system followed by classification symbols)  
 B65B B65G

Documentation searched other than minimum documentation to the extent that such documents are included in the fields searched

Electronic data base consulted during the international search (name of data base and, where practicable, search terms used)

EPO-Internal , WPI Data

**C. DOCUMENTS CONSIDERED TO BE RELEVANT**

Category*	Citation of document, with indication, where appropriate, of the relevant passages	Relevant to claim No.
A	US 6 347 709 B1 (BI EHL JOHANN [DE] ET AL) 19 February 2002 (2002-02-19) abstract figures 1-7 column 4, line 27 - line 31 column 9, line 19 - line 27 -----	1-18
A	DE 10 2004 028212 A1 (BOSCH GMBH ROBERT [DE]) 29 December 2005 (2005-12-29) abstract figure 1 -----	1-18
A	EP 0 842 878 A1 (IMA SPA [IT]) 20 May 1998 (1998-05-20) the whole document -----	1-18
	- / - -	

Further documents are listed in the continuation of Box C.

See patent family annex.

\* Special categories of cited documents :

"A" document defining the general state of the art which is not considered to be of particular relevance  
 "E" earlier application or patent but published on or after the international filing date  
 "L" document which may throw doubts on priority claim(s) or which is cited to establish the publication date of another citation or other special reason (as specified)  
 "O" document referring to an oral disclosure, use, exhibition or other means  
 "P" document published prior to the international filing date but later than the priority date claimed

"T" later document published after the international filing date or priority date and not in conflict with the application but cited to understand the principle or theory underlying the invention  
 "X" document of particular relevance; the claimed invention cannot be considered novel or cannot be considered to involve an inventive step when the document is taken alone  
 "Y" document of particular relevance; the claimed invention cannot be considered to involve an inventive step when the document is combined with one or more other such documents, such combination being obvious to a person skilled in the art  
 "&" document member of the same patent family

Date of the actual completion of the international search

15 September 2014

Date of mailing of the international search report

26/09/2014

Name and mailing address of the ISA/

European Patent Office, P.B. 5818 Patentlaan 2  
 NL - 2280 HV Rijswijk  
 Tel. (+31-70) 340-2040,  
 Fax: (+31-70) 340-3016

Authorized officer

Dami ani , Albert o

# INTERNATIONAL SEARCH REPORT

International application No  
PCT/IB2014/061333

C(Continuation). DOCUMENTS CONSIDERED TO BE RELEVANT

Category*	Citation of document, with indication, where appropriate, of the relevant passages	Relevant to claim No.
A	GB 2 364 290 A (BOSCH GMBH ROBERT [DE]) 23 January 2002 (2002-01-23) abstract figure 2  -----	1-18

# INTERNATIONAL SEARCH REPORT

Information on patent family members

International application No

PCT/IB2014/061333

Patent document cited in search report	Publication date	Patent family member(s)	Publication date
US 6347709	BI	19-02- -2002	AT 356029 T 15-03-2007
			DE 19841508 CI 21-10-1999
			EP 0987179 A2 22-03-2000
			US 6347709 BI 19-02-2002
-----			
DE 102004028212	AI	29-12- -2005	NONE
-----			
EP 0842878	AI	20-05- -1998	DE 842878 TI 09-12-1999
			DE 69710421 DI 21-03-2002
			DE 69710421 T2 02-10-2002
			EP 0842878 AI 20-05-1998
			IT B0960587 AI 15-05-1998
			US 5862646 A 26-01-1999
			US 6070385 A 06-06-2000
-----			
GB 2364290	A	23-01- -2002	DE 10026497 AI 29-11-2001
			FR 2810633 AI 28-12-2001
			GB 2364290 A 23-01-2002
			SE 0101811 A 28-11-2001
-----			