

No. 641,114.

Patented Jan. 9, 1900.

N. D. INGRAM.  
UMBRELLA RUNNER.

(Application filed Sept. 11, 1899.)

(No Model.)

Fig. 1.

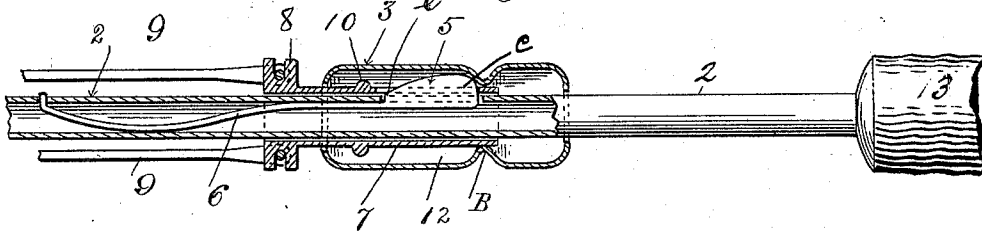

Fig. 2.

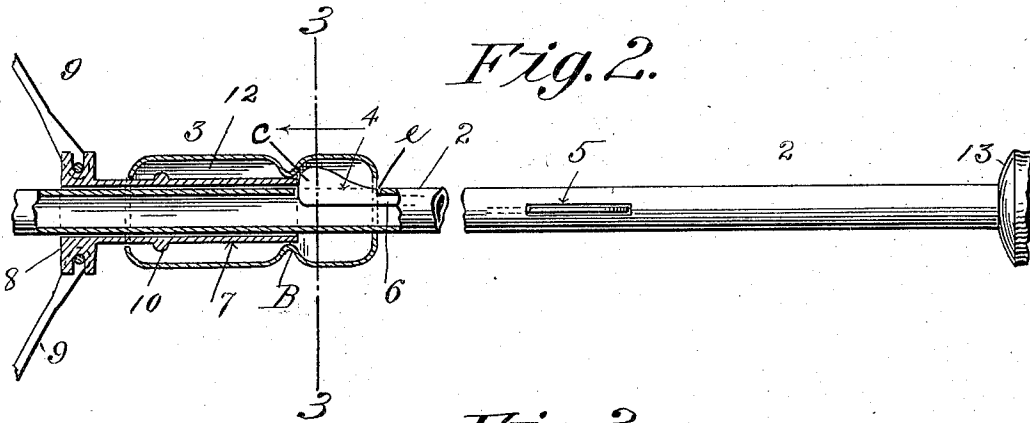
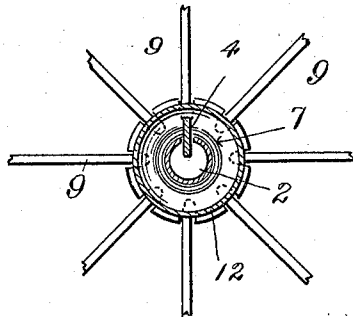

Fig. 3.



Witnesses:  
J. H. Garfield  
H. J. Clemons

Inventor,  
Nathan D. Ingram.  
by *Seapine & Co.*  
Attorneys.

# UNITED STATES PATENT OFFICE.

NATHAN D. INGRAM, OF HOLYOKE, MASSACHUSETTS.

## UMBRELLA-RUNNER.

SPECIFICATION forming part of Letters Patent No. 641,114, dated January 9, 1900.

Application filed September 11, 1899. Serial No. 730,086. (No model.)

*To all whom it may concern:*

Be it known that I, NATHAN D. INGRAM, a citizen of the United States of America, residing at Holyoke, in the county of Hampden and State of Massachusetts, have invented new and useful Improvements in Umbrella-Runners, of which the following is a specification.

This invention relates to umbrella-runners, the object being to provide a runner of improved construction containing means acting automatically through the act of moving the runner to open or close the umbrella to disengage the usual spring-catches of the handle therefrom, which retain the umbrella either closed or open, thereby obviating the inconvenient manipulation of said catches by the fingers; and the invention consists in the peculiar construction of the runner whereby said object is attained.

In the drawings forming part of this specification, Figure 1 is a side elevation, partly in section, of the lower end of an umbrella stick or rod and of the runner-catch and a part of the umbrella-handle, showing in longitudinal section an umbrella-runner embodying my invention and illustrating the relative positions of the lower runner-catch and said runner when the umbrella may be closed. Fig. 2 is a similar view to Fig. 1, showing said lower rod-section and the projecting part of the runner-catch and a sectional view of a part of the upper portion of said rod with the runner-catch therein and illustrating said runner in longitudinal section and the relative positions of the upper runner-catch and said runner when the umbrella may be open.

Referring to the drawings, 2 indicates parts of an umbrella-rod, (in this case shown to be tubular,) one of said parts showing the runner 3 engaging the upper runner-catch 4 and the other of said parts showing said runner engaging the lower runner-catch 5. Each of said runner-catches has a flexible spring extension 6, secured in or to the rod, and the catch proper, 5, projecting through a suitable slot and normally and yieldingly held in the positions shown for engagement with said runner, the position of Fig. 1 being through a slot *e* and that of Fig. 2 being under the lower end of the runner.

The improved runner herein shown in Figs. 1 and 2 consists of the inner metallic runner-tube 7, which slides directly on said rod, which has on its upper end the circular head 8, to which the usual braces 9 of the cover-frame are pivoted, and having a short distance below said head a beaded or other similar lateral projection 10 and a slot *e* through one side near its lower end, which provides for the movement therethrough inwardly and outwardly of the lower runner-catch 5 only, as shown in Fig. 1, for the purpose of holding the runner while the umbrella is closed and releasing the same for opening it. Unlike umbrella-runner devices of this class heretofore made, those herein described comprise a catch-operating tubular slide 12, which normally incloses all that part of said inner runner-tube 7 from just under the said head 8 thereon to and including the lower extremity thereof, as shown in Figs. 1 and 2 of the drawings. By so inclosing the lower end of said tube 7 the inconvenience arising from the presence of the lower end of the latter below the catch-operating slide in attempting to move the runner upward for opening the umbrella is obviated, and, furthermore, said slide wholly protects the inclosed runner and catch parts from injury. Said catch-operating tubular slide 12 has its upper and lower ends inturned, as shown, leaving open ends of slightly-greater diameters than the said rod 2 and the said runner-tube 7, whereby free longitudinal movements on said rod and tube are provided for. Said beaded projection 10 on said tube 7 is of greater diameter than the opening in the adjoining end of the said slide 12, and therefore the movement of the latter on the runner-tube 7 is limited to the distance between said projection and the said head 8. Said catch-operating slide 12 has an annular projection formed at B on its inner wall, preferably by making a circular exterior depression, as shown. Said annular projection has an internal diameter slightly in excess of the diameter of said runner-tube 7 and is of suitable conformation to form proper abutments for the upper and lower runner-catches 4 and 5, respectively, whereby when the umbrella is closed said catch 5 engages said abutment, as shown in Fig. 1, and when open or spread the catch 4 engages the same, as in Fig. 2.

The operation of the above-described devices, whereby the movement of a part of the runner in the direction required of the entire runner to open or close the umbrella effects the disengagement of said catches, is as follows: Assuming that the runner parts occupy the positions shown in Fig. 1, whereby the umbrella is held closed, the operator grasps the said slide 12 and moves the same upwardly against the under side of the head 8, and such movement carries the inwardly-projecting part B of said slide against the border of the catch 5 and so depresses the same within the rod 2 that only that part of its border whose ends are curved lies within said slot e, and hence the continued movement of said outer element carries the now-unobstructed runner-tube 7 and the braces 9 upwardly to the positions shown in Fig. 2, thus opening the umbrella. Said runner in passing upwardly, as stated, has its upper extremity carried against the tapering border of the lower end of the projecting part of the upper runner-catch 4, Fig. 2, thus driving the latter inwardly and allowing said runner-tube 7 to pass over it and slightly above the same, when the catch springs outwardly to the position shown in the last-named figure and holds the umbrella-braces 9 in the opened positions shown.

In closing the umbrella the slide 12, by which the said catches are normally covered or inclosed, is simply drawn downwardly, first causing said inwardly-projecting part of said slide to crowd the upper runner-catch 4 inwardly of rod 2 and then bringing the upper end of the said slide 12 against the bead or projection 10 of the runner-tube 7, thus leaving the runner free to be drawn down and close the umbrella by the continued downward movement of said slide. Upon reaching the lower runner-catch 5 the lower end of said slide 12 first moves against the border of said catch, carrying the latter inwardly of the rod 2, and the said inwardly-projecting part of said slide follows said lower end in engaging

the catch, and upon passing the free end of the latter the parts take the positions shown in Fig. 1, wherein the said free end of the catch 5 is shown to be engaged against the upper side of said projecting part, and thus holding the runner in the position it occupies when the umbrella is closed.

It is quite universally the case that the construction of umbrella-runners and the catches therefor embody more or less disagreeable points and ends of parts to be grasped by the hand when the umbrella is to be opened or closed, and particularly so when haste must be used; but it will be noted that the single operating element of the runner parts herein described—viz., the slide 12—is a cylinder the borders of whose extremities are curved, as well as the borders of the annular depression B thereof. Consequently, regardless of the rapidity of the movement of the fingers in grasping the slide, no inconvenience can result therefrom.

Having thus described my invention, what I claim, and desire to secure by Letters Patent of the United States, is—

An umbrella-runner comprising an inner tube having a projection thereon, and a catch-operating tubular slide of greater length than the inner tube and embracing and inclosing said inner tube, and having sliding connection therewith limited to the distance between one end of the tube and the projection on the tube, said catch-operating slide bent inward at its opposite ends and having a circumferential constriction formed intermediate of the ends, one slope of which constriction is adapted to have a cam action on one of the umbrella-catches and the other slope upon the other, to depress them preparatory to the runner being locked in either of its extreme positions.

NATHAN D. INGRAM.

Witnesses:

H. A. CHAPIN,  
K. I. CLEMONS.