

H. MACON.  
 Improvement in Belt-Shifting Devices for Spinning-Mules.  
 No. 131,762.      Patented Oct. 1, 1872.

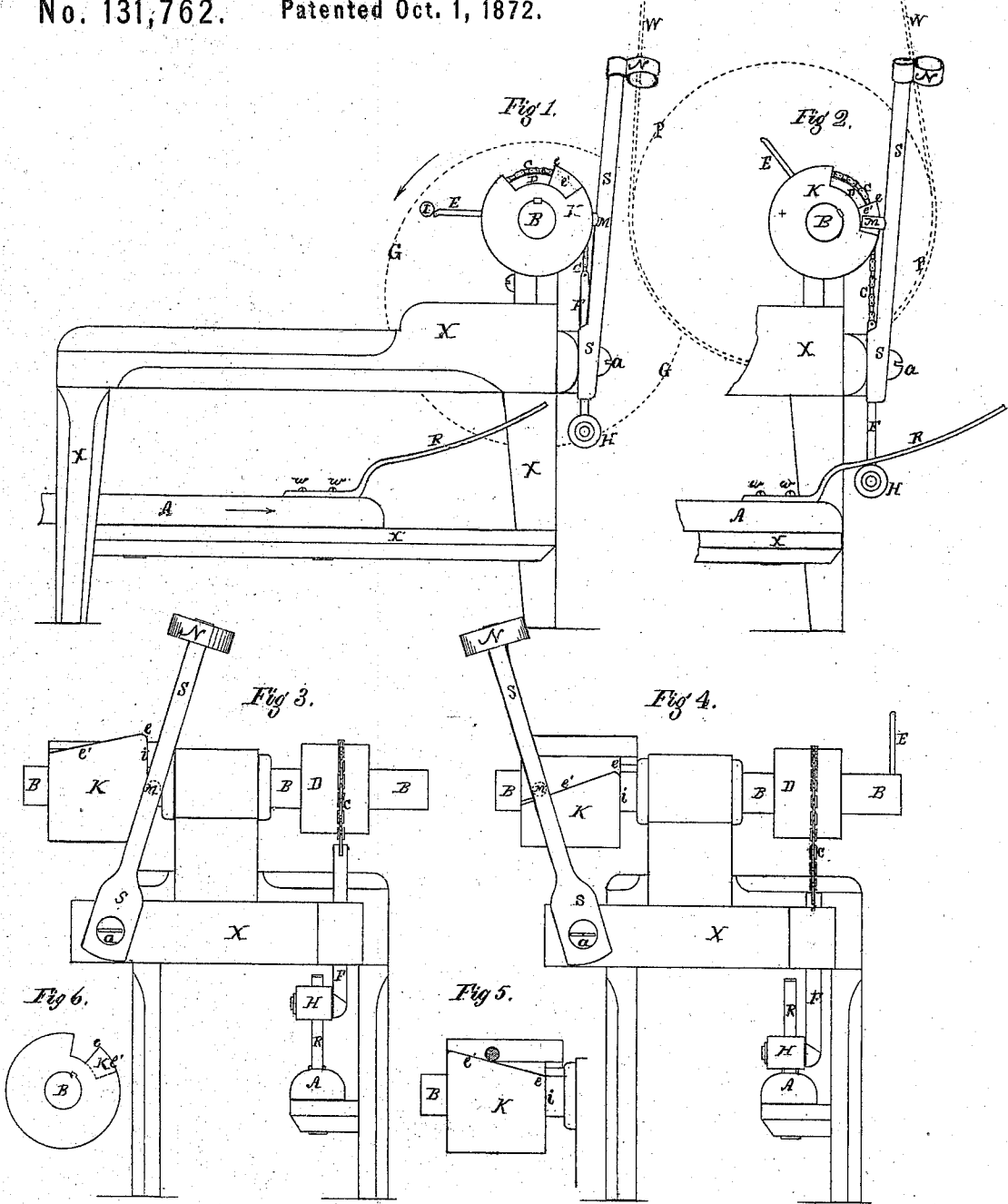

Witnesses.

*James A. Brown*  
*Elijah Potter*

Inventor.

*H. Macdonald*

# UNITED STATES PATENT OFFICE.

HEZEKIAH MACON, OF PROVIDENCE, RHODE ISLAND.

IMPROVEMENT IN BELT-SHIFTING DEVICES FOR SPINNING-MULES.

Specification forming part of Letters Patent No. 131,762, dated October 1, 1872.

*To all whom it may concern:*

Be it known that I, HEZEKIAH MACON, of the city and county of Providence and State of Rhode Island, have invented a new and Improved Mechanical Device for Regulating and Controlling the Belt-Shifting Mechanism of Self-Operating Mules, of which the following is a specification, referring by letters marked thereon to the accompanying drawing making part of the same, in which—

Figure 1 is a side elevation of the said device in connection with certain parts (some of which are shown in dotted lines) of a "mule-head;" Fig. 2 is a like view of the same with the parts of the device reversed from their position in Fig. 1; Fig. 3 is an end view of the device in the position of Fig. 1; Fig. 4 is an end view with the parts in the position of Fig. 2; Fig. 5 is a front view; and Fig. 6 is an end view of a modification of the cam K herein referred to, but reversed in form and action from that shown in the other figures.

Similar letters indicate like parts in all the figures.

My invention relates to a mechanical device for regulating and controlling the belt-shifting mechanism by which the movement of the mule-carriage is reversed and the spindles started preparatory to running out and resuming the spinning operation in such a manner as to start the spindles in anticipation of the reversing of the carriage, to retard or make such starting gradual for the finer numbers of yarn, and to be capable of adjustment to operate in concert with other relative mechanism and according to the nature of the work to be performed.

The said mechanical device consists of the cam K on the cam-shaft B, to which is given a partial rotative movement, alternately, in opposite directions, by means of the chain C on the drum D in one direction, and the arm E, which is moved by the stud-pin I on the face of the escape-plate G, (in dotted lines,) in the opposite direction. The chain C is attached by one end to the drum D and by its other end to a guide-rod, F, having a roller, H, at the lower end suspended in line with a dagger, R, on the mule-carriage A, so that, by the forward movement of the carriage (in the direction indicated by the arrow) the dagger will be thrust above the roller H, and, bearing it downward, pull the rod and chain and rotate

the cam-shaft and cam K to a certain extent to change the position of the cam K with reference to the stud M on the shipper S, by which the shifting action of the latter is controlled, to shift the belt W from one of a pair of driving-pulleys, P, (in dotted lines,) to the other, to effect the reversing of the carriage and the starting of the spindles above referred to, after which, and after the belt is shifted back again, as hereinafter described, the cam K is returned to its first position by the stud-pin I acting against the lever or arm E in the direction indicated by the arrow. The shipper-lever S is pivoted at *a* to the frame X of the mule-head, and has at its top a belt-guide, N. It is shifted from the position shown in Fig. 3 to that of Fig. 4 by a weight or spring, or both, and in the opposite direction by the positive action of a cam on the shaft with the driving-pulleys, and both these shifting movements are controlled by the action of the cam K against the stud M on the shipper-lever, as follows, viz.: In the position shown in Figs. 1 and 3 the stud M bears with the force of the said weight or spring against the side face *i* of the cam K, which holds the shipper in this position while the carriage runs up and winds the yarn on the cop. In running up, the dagger R on the carriage strikes the roller H, pulls the chain, and turns the cam K down and liberates the stud M at the point *e*, when the shipper is suddenly shifted, by the force of the weight or spring, to the opposite position, shown in Figs. 2 and 4, thereby shifting the belt to the pulley, which starts the spindles to resume the spinning operation. The dagger R, from which the sudden movement of the cam is derived, is so placed upon the carriage A as to strike the roller and liberate the shipper from the cam before the carriage has completed its running-up movement, so that the sudden shifting of the belt and starting of the spindles takes place in advance of and is in progress at the time when the reversing action of the carriage takes place at the end of the running-up movement. By this swift prerunning stroke of the dagger to liberate the shifting mechanism from the custody of the cam K, in anticipation of the reversing action of the carriage, a gain of about seven seconds in each minute, or one hour and ten minutes in each working-day of ten hours, is realized, or a clear gain of fully one-tenth

in the product in each day's operation of the machine is due to the application of this mechanical device to the shifting mechanism, as described. The face  $e'$  of the cam K is inclined downward or falls off from the point  $e$ , as shown in Figs. 3 and 4, so that the stud M will swing clear of the face  $e'$  when liberated from the point  $e$  and avoid obstructing the sudden shifting movement of the shipper; but in spinning the finer numbers of yarns—say 60's or thereabout—the sudden starting of the spindles above described would be liable to break the yarns frequently, so that it becomes necessary to qualify the action of the mechanism or device to adapt it to the demands of this kind of work. This is accomplished by shaping the inclined face  $e'$  of the cam K, as shown in Figs. 5 and 6, or by inclining the face in the opposite direction, so that, instead of liberating the stud M immediately and clearly from the point  $e$  of the cam, the stud M, on passing said point, will rest against the upward-inclined face  $e'$ , and drag thereon and retard the shifting action of the shipper S, and start the spindles gradually and without the strain on the yarns consequent upon a sudden start from a state of rest, so that the advantage of gain in product may be derived equally in spinning the finer as in the coarser yarns.

In the use of a mechanical device of this nature to act at as critical a point of a machine's operation as that between the entire reversal and change of its movements it is essential that

it should be susceptible of such adjustment as would cause it to act in concert with the parts which are immediately affected by its action. This is accomplished by slightly elevating or depressing the dagger R with reference to the carriage A, by means of the screws  $w$ , by which it is secured thereon, or otherwise. By elevating the dagger it will strike the roller H at a later period in the progress of the carriage to the reversing-point, and by depressing the dagger it will strike the roller and liberate the shifting mechanism at an earlier period of its progress. In either case the dagger, by its form and the velocity with which it is carried in "running up," is swift and sure of action at the required point in the operation of the machine.

I claim as my invention—

1. The cam K, operated by the dagger R from the movement of the carriage A, in combination with the belt-shifting mechanism, substantially as described, for the purpose specified.
2. The cam K constructed as described, to retard and graduate the action of the shifting mechanism after being liberated, in the manner and for the purpose specified.
3. The adjustable dagger R, as described, to effect the liberating of the shifting mechanism, in the manner and at the time specified.

HEZEKIAH MACON.

Witnesses:

ISAAC A. BRUMELL,  
ELIJAH POTTER.