

(19) **DANMARK**

(10) **DK/EP 4147769 T3**



(12)

Oversættelse af europæisk patentskrift

Patent- og
Varemærkestyrelsen

-
- (51) Int.Cl.: **B 01 D 61/14 (2006.01)** **B 01 D 63/04 (2006.01)** **B 01 D 63/12 (2006.01)**
- (45) Oversættelsen bekendtgjort den: **2025-06-16**
- (80) Dato for Den Europæiske Patentmyndigheds bekendtgørelse om meddelelse af patentet: **2025-05-21**
- (86) Europæisk ansøgning nr.: **22205067.6**
- (86) Europæisk indleveringsdag: **2015-08-28**
- (87) Den europæiske ansøgnings publiceringsdag: **2023-03-15**
- (30) Prioritet: **2014-08-29 US 201462043846 P**
- (62) Stamansøgningsnr: **15760044.6**
- (84) Designerede stater: **AL AT BE BG CH CY CZ DE DK EE ES FI FR GB GR HR HU IE IS IT LI LT LU LV MC MK MT NL NO PL PT RO RS SE SI SK SM TR**
- (73) Patenthaver: **EMD Millipore Corporation, 400 Summit Drive, Burlington, MA 01803, USA**
- (72) Opfinder: **STEEN, Jonathan, , Billerica, 01821, USA**
KOZLOV, Mikhail, , Billerica, 01821, USA
LUTZ, Herbert, , Billerica, 01821, USA
PARRELLA, Joseph, , Billerica, 01821, USA
GOODRICH, Elizabeth M., , Billerica, 01821, USA
RAGHUNATH, Bala, , Billerica, 01821, USA
- (74) Fuldmægtig i Danmark: **Zacco Denmark A/S, Arne Jacobsens Allé 15, 2300 København S, Danmark**
- (54) Benævnelse: **Fremgangsmåder til filtrering af væsker ved hjælp af enkelt passage-tangentielle strømningfiltreringssystemer og tangentielle strømningfiltreringssystemer med recirkulation af retentat**
- (56) Fremdragne publikationer:
WO-A2-2007/076496
US-A- 5 147 542
US-A1- 2003 066 794
US-A1- 2006 144 788
US-A1- 2009 266 756
US-B1- 8 506 802
JEMELLE DIZON-MASPAT ET AL: "Single pass tangential flow filtration to debottleneck downstream processing for therapeutic antibody production", BIOTECHNOLOGY AND BIOENGINEERING, vol. 109, no. 4, 1 April 2012 (2012-04-01), pages 962 - 970, XP055050387, ISSN: 0006-3592, DOI: 10.1002/bit.24377
A. S. RATHORE ET AL: "RECENT DEVELOPMENTS IN MEMBRANE-BASED SEPARATIONS IN BIOTECHNOLOGY PROCESSES: REVIEW", PREPARATIVE BIOCHEMISTRY AND BIOTECHNOLOGY, vol. 41, no. 4, 1 October 2011 (2011-10-01), pages 398 - 421, XP055153231, ISSN: 1082-6068, DOI: 10.1080/10826068.2011.613976
REIS VAN R ET AL: "LINEAR SCALE ULTRAFILTRATION", BIOTECHNOLOGY AND BIOENGINEERING, WILEY & SONS, HOBOKEN, NJ, US, vol. 55, no. 5, 5 September 1997 (1997-09-05), pages 737 - 746, XP000699680,

Fortsættes ...

ISSN: 0006-3592, DOI: 10.1002/(SICI)1097-0290(19970905)55:5<737::AID-BIT4>3.0.CO;2-C
CATHERINE CASEY ET AL: "Protein concentration with single-pass tangential flow filtration (SPTFF)",
JOURNAL OF MEMBRANE SCIENCE, ELSEVIER BV, NL, vol. 384, no. 1, 3 September 2011 (2011-09-03), pages
82 - 88, XP028319561, ISSN: 0376-7388, [retrieved on 20110910], DOI: 10.1016/J.MEMSCI.2011.09.004

DESCRIPTION

Description

BACKGROUND OF THE INVENTION

[0001] Tangential flow filtration (TFF) is a separation process that uses membranes to separate components in a liquid solution or suspension on the basis of size, molecular weight or other differences. Serializing the flow path of the liquid feed from one filtration module to the next in the TFF system can improve conversion by increasing fluid residence time in membrane modules. Traditional TFF processes typically rely on added TFF system components, such as diverter plates, to serialize the flow path of the liquid feed through the TFF system. Diverter plates, however, add cost and certain complexity to the system, and require additional operator training.

[0002] Accordingly, there is a need for improved TFF systems and processes that do not require diverter plates, or custom module assemblies, for effective serial processing of liquids. In addition, there is a present need for TFF systems and processes that include diafiltration using a serialized flow path to permit continuous flow and potentially more efficient bioprocessing at an industrial scale.

Various filtration systems are disclosed in: WO 2007/076496 A2; JEMELLE DIZON-MASPAT ET AL (DOI: 10.1002/bit.24377); and US 2003/066794 A1.

SUMMARY OF THE INVENTION

[0003] In one embodiment, the present invention relates to a method of filtering a liquid feed in accordance with claim 1.

[0004] In another aspect of this disclosure, the SPTFF system consists of one filtration module. The filtration module comprises a feed inlet, a retentate outlet, a manifold segment that comprises a first manifold for receiving and carrying the feed into the filtration module, a second manifold for receiving and carrying retentate out of the filtration module, and a third manifold for receiving and carrying permeate through the filtration module, wherein the flow path through the manifold segment is serial, and one or more TFF capsules that are positioned on one or both faces of, and are fluidly connected to, the manifold segment, wherein the liquid flow path is parallel through the capsules.

[0005] In another embodiment, the invention relates to a method of filtering a liquid feed in

accordance with claim 2.

[0006] In another aspect of this disclosure, the TFF system consists of one filtration module. The filtration module comprises a feed inlet, a retentate outlet, a recirculation loop (e.g., a pump) for recirculating retentate through all or part of the system, at least one conduit for recirculating retentate, a manifold segment that comprises a first manifold for receiving and carrying the feed into the filtration module, a second manifold for receiving and carrying retentate out of the filtration module, and a third manifold for receiving and carrying permeate through the filtration module, wherein the flow path through the manifold segment is serial, and a plurality of TFF capsules that are positioned on one or both faces of, and are fluidly connected to, the manifold segment, wherein the liquid flow path is parallel through the capsules.

BRIEF DESCRIPTION OF THE DRAWINGS

[0007]

FIG. 1 is a diagram showing three vertically-stacked manifold segments 1 having a manifold arrangement that facilitates a serial flow path for feed and retentate.

FIG. 2A is a diagram depicting a side view of a single manifold segment 1 that is loaded with four capsules 2 on each side of the segment.

FIG. 2B is a diagram depicting an end view of the single manifold segment 1 depicted in FIG. 2A, showing the four capsules 2 on each side of the segment.

FIG. 2C is a diagram depicting a top view of the single manifold segment 1 depicted in FIGs. 2A and 2B, showing only the uppermost capsule 2 on each side of the segment.

FIG. 3 is an example TFF system configured for recirculation of at least a portion of the retentate; n represents the number of filter modules (n=0 to 8).

[0008] The foregoing will be apparent from the following more particular description of example embodiments of the invention, as illustrated in the accompanying drawings in which like reference characters refer to the same parts throughout the different views. The drawings are not necessarily to scale, emphasis instead being placed upon illustrating embodiments of the present invention.

DETAILED DESCRIPTION OF THE INVENTION

[0009] A description of example embodiments of the invention follows.

Definitions

[0010] Unless defined otherwise, all technical and scientific terms used herein have the same meaning as commonly understood by one of ordinary skill in the art to which this invention pertains.

[0011] "SPTFF assembly," "SPTFF system" and "SPTFF apparatus" are used interchangeably herein to refer to a single pass tangential flow filtration system that is configured for operation in a single-pass mode, where the fluid passes once through the system.

[0012] "TFF assembly," "TFF system" and "TFF apparatus" are used interchangeably herein to refer to a tangential flow filtration system that is configured for operation a recirculation mode where at least a portion of the retentate is returned to the system as feed.

[0013] The terms "feed," "feed sample" and "feed stream" refer to the solution that is delivered (e.g., continuously, as a batch) to a filtration module to be filtered. The feed that is delivered to a filtration module for filtration can be, for example, feed from a feed container (e.g., vessel, tank) external to the system, or retentate from a preceding filtration module in the same system (e.g., in SPTFF and TFF systems operated in serial processing mode).

[0014] The term "filtration" generally refers to the act of separating the feed sample into two streams, a permeate and a retentate, using membranes.

[0015] The terms "permeate" and "filtrate" refer to that portion of the feed that has permeated through the membrane.

[0016] The term "retentate" refers to the portion of the solution that has been retained by the membrane, and the retentate is the stream enriched in a retained species.

[0017] "Feed line" or "feed channel" refers to a conduit for conveying a feed from a feed source (e.g., a feed container) to one or more processing units in a filtration assembly (e.g., a TFF system).

[0018] "Retentate line" or "retentate channel" refers to a conduit in a filtration assembly for carrying retentate.

[0019] "Permeate line" or "permeate channel" refers to a conduit in a filtration assembly for carrying permeate.

[0020] The expression "flow path" refers to a channel supporting the flow of a liquid (e.g., feed, retentate, permeate) through all or part of an SPTFF or a TFF system. Thus, an SPTFF and a TFF system can have multiple flow paths, including a flow path through the entire system from

the feed inlet to the retentate outlet, a flow path within a filtration module (e.g., a flow path through TFF capsules and/or a manifold segment in a filtration module) and a flow path between two or more adjacent filtration modules (e.g., a flow path between manifold segments in adjacent filtration modules). The flow path can have any topology which supports tangential flow (e.g., straight, coiled, arranged in zigzag fashion). The flow path can be parallel or serial. A flow path can also refer to a path resulting in a single pass through an SPTFF system or a path for recirculating retentate through a TFF system. Furthermore, a flow path can be open, as in an example of channels formed by hollow fiber membranes, or have one or more flow obstructions, as in the case, for example, of rectangular channels formed by flat-sheet membranes spaced apart by woven or non-woven spacers.

[0021] A "filtration module" refers to a unit in an SPTFF or a TFF system comprising a manifold segment and one or more TFF capsules.

[0022] A "manifold segment" refers to a block having a plurality of manifolds, including a manifold for carrying a feed, a manifold for carrying a retentate and a manifold for carrying a permeate.

[0023] A "TFF cartridge" or "TFF capsule" refers to a spiral wound element or hollow fiber filter bundle in a self-contained roughly cylindrical housing containing a filtration membrane and separate feed/retentate and permeate flow channels suitable for SPTFF and TFF processes.

[0024] "Filtration membrane" refers to a selectively permeable membrane for separating a feed into a permeate stream and a retentate stream using an SPTFF or a TFF process. Filtration membranes include, but are not limited to, ultrafiltration (UF) membranes, microfiltration (MF) membranes, reverse osmosis (RO) membranes and nanofiltration (NF) membranes.

[0025] The terms "ultrafiltration membrane" and "UF membrane" are used herein to refer to a membrane that has pore sizes in the range of between about 1 nanometer to about 100 nanometers.

[0026] The term "microfiltration membranes" and "MF membranes" are used herein to refer to membranes that have pore sizes in the range between about 0.1 micrometers to about 10 micrometers.

[0027] The term "plurality," when used herein to describe processing units, refers to two or more processing units.

[0028] "Fluidly connected" refers to two or more components of an SPTFF or a TFF system (e.g., two or more manifold segments, two or more TFF capsules, a manifold segment and one or more TFF capsules), that are connected by one or more conduits (e.g., a feed channel, a retentate channel, a permeate channel) such that a liquid can flow from one component to the other.

[0029] "Product" refers to a target compound in a feed. Typically, a product will be a biomolecule (e.g., protein) of interest, such as a monoclonal antibody (mAb).

[0030] "Processing" refers to the act of filtering (e.g., by SPTFF or TFF) a feed containing a product of interest and subsequently recovering the product in a concentrated form. The concentrated product can be recovered from the filtration system (e.g., an SPTFF or a TFF system) in either the retentate stream or permeate stream depending on the product's size and the pore size of the filtration membrane.

[0031] The expressions "parallel processing", "processing in parallel", "parallel operation" and "operation in parallel" refer to distributing a liquid in an SPTFF or a TFF system to two or more filtration units (e.g., filtration modules, TFF capsules) in the assembly concurrently, or in rapid succession, for subsequent tangential flow filtration.

[0032] The expressions "serial processing", "processing in series", "serial operation" and "operation in series" refer to distributing a liquid in an SPTFF or a TFF system to one filtration unit (e.g., filtration module, TFF capsule) at a time, such that the retentate flow of a preceding unit serves as the feed flow for a subsequent, adjacent unit.

[0033] The expressions "conversion" and "conversion per pass" are used herein to denote the fraction of the feed volume that permeates through the membrane in a pass through the flow channels, expressed as a percentage of the feed stream volume.

[0034] The term "residence time" refers to holdup volume on the feed side of the membrane divided by flow rate.

[0035] The term "single-pass TFF mode" refers to operating conditions for an SPTFF or a TFF system under which the retentate is not recirculated through the system.

Methods of the Invention

[0036] In contrast, the methods described herein, also referred to as the "methods of the invention" can be performed using an SPTFF or a TFF system that comprises manifold segments to serialize the flow path of the feed and retentate without requiring diverter plates. For example, the diagram in FIG. 1 depicts three vertically-stacked manifold segments 1 having a manifold arrangement that facilitates a serial flow path for feed and retentate. Manifolds within the segments are depicted using dashed lines. The flow path for feed and retentate is shown using single-line arrows and the permeate flow path is shown with a double-line arrow. The flow path for the feed and retentate is serialized, as the retentate of the preceding, lower module serves as the feed for the following module above. The middle manifold is used for permeate.

Methods of the Invention Using Single-Pass Tangential Flow Filtration (SPTFF)

[0037] In one embodiment, the invention relates to a method of filtering a liquid feed comprising passing a liquid feed through a single pass tangential flow filtration (SPTFF) system and recovering the retentate and permeate from the system in separate containers.

[0038] The liquid feed can be any liquid (e.g., a biological liquid) that contains particles (e.g., viral particles, host cell proteins) to be filtered. For example, the liquid feed can contain a target molecule of interest (e.g., a target protein, such as a recombinant protein) and one or more impurities (e.g., non-target proteins). Typically, the liquid feed is obtained from a source of the target molecule (e.g., a hybridoma or other host cell expressing a monoclonal antibody (MAb)). In a particular embodiment, the target molecule in the liquid feed is a MAb and the non-target molecules are host cell proteins (HCPs) (e.g., proteins from host hybridoma cells). Non-target proteins are generally a heterogeneous mixture of proteins of varying sizes, hydrophobicities and charge densities. In another embodiment, the liquid feed contains one or more viruses (e.g., for virus filtration processes). In yet another embodiment, the liquid feed includes plasma products.

[0039] An SPTFF system allows direct flow-through concentration of a product (e.g., target protein) in the absence of recirculation, which reduces overall system size through elimination of mechanical components and permits continuous operation at high conversion levels. Thus, SPTFF systems and processes provide several advantages over traditional TFF systems and processes.

[0040] In general, SPTFF systems that are useful for the present invention can be assembled and operated using standard, existing TFF system components that are well known and are commercially available. Standard TFF system components include, for example, TFF capsules comprising filtration membranes, capsule holders, conduits (e.g., tubing, piping) for feed, retentate and permeate, a housing or enclosure, valves, gaskets, a pump module (e.g., pump module comprising a pump housing, diaphragm and check valve) one or more reservoirs (e.g., process containers for feed, retentate and permeate) and a pressure gauge.

[0041] In accordance with the invention, the liquid feed is passed (e.g., pumped) through an SPTFF system that comprises a plurality of filtration modules. In general, each filtration module comprises a manifold segment that includes a first manifold for receiving and carrying the feed into the filtration module, a second manifold for receiving and carrying retentate out of the filtration module, and a third manifold for receiving and carrying permeate through the filtration module. The manifold segment is fluidly connected to one or more TFF capsules that are positioned on one or both faces of the manifold segment. The feed inlet is on the first filtration module in the system (e.g., the module that first receives the feed directly through a channel comprising the feed pump) and the retentate outlet is on the final, or last, filtration module in the system.

[0042] The SPTFF system contains a plurality of filtration modules.

[0043] Each manifold segment has a manifold structure, or arrangement, that permits the segment to be fluidly connected to manifold segments in adjacent filtration modules. The manifold segments are connected in a manner that promotes a serial flow path from manifold segment to manifold segment (see, e.g., FIG. 1). For example, adjacent manifold segments are arranged such that the first manifold in each manifold segment is connected to the second manifold of an adjacent manifold segment. As a result of this arrangement, the retentate of one module (which exits the module through the second manifold in the manifold segment) serves as the feed for the next module (which is received in the first manifold of the manifold segment). A third manifold in the manifold segment provides a separate path for discharging the permeate from the filtration modules.

[0044] The manifolds in the manifold segments in an SPTFF system can have identical diameters, or different diameters, from manifold segment to manifold segment. For example, the diameter of the manifolds can be progressively smaller from manifold segment to manifold segment. Decreasing manifold diameter through series helps maintain fluid velocity for flush and cleaning through the different sections as fluid is lost to the permeate in each section. This may also aid in removing air, increasing maximum concentration factor, and increasing product recovery and/or reducing product dilution. In particular embodiments, each manifold segment has manifolds having the same diameter from one end to the next (e.g., the manifolds are not tapered). In other embodiments, the manifolds can be tapered.

[0045] In the invention, parallel flow between adjacent manifold segments can be prevented using valves (e.g., sanitary valves) to facilitate a serial flow path between modules. Valves are positioned in the manifolds that carry feed and retentate to enable blocking liquid from flowing in a parallel fashion into adjacent manifold segments. The use of valves to prevent parallel flow is particularly desirable when the manifold segments are fully bored, such that the first, second and third manifolds each extend completely through the manifold segment.

[0046] Suitable seals (e.g., mechanical seals) for placement in manifolds include, but are not limited to, rings (e.g., o-rings, metal rings), molding, packing, sealants and gaskets. Preferably, the seal is a gasket, such as, for example, a gasket that closes off an opening or a gasket having a length sufficient to closes off any dead volume between the opening and a first passage in a manifold. Preferably, the gasket is flexible and sanitary (e.g., a gasket that is non-shedding, cleanable, sanitizable, and has low extractables). The gasket can include an elastomeric material or metal (e.g., a metal foil). An exemplary gasket is part# A84MP-G from Newman Gasket Co., Lebanon, OH.

[0047] The use of valves instead of seals provides greater operational flexibility by permitting parallel flow between manifold segments when the valves are open, and serial flow when the valves are closed. Suitable valves for use in manifolds include, for example, pinch valves (e.g., diaphragm valve). Preferably, the valve is low shear and sanitary (e.g., compatible, non-toxic, sanitizable, non-shedding). As used herein, a "sanitary valve" is a valve that can maintain a

sterile connection regardless of whether the valve is open or closed. Typically, a sanitary valve will be compatible, non-toxic, sanitizable and non-shedding.

[0048] Parallel flow between adjacent manifold segments can be prevented by the use of manifold segments that do not have fully-bored manifolds for carrying feed and retentate. For example, manifold segments with first and second manifolds that do not extend through the entire manifold segment can be used to prevent parallel flow of feed and retentate, respectively, between adjacent manifold segments to facilitate a serial flow path between modules. Typically, such manifold segments will contain a separate third manifold for carrying permeate that does extend the entire length of the segment for carrying permeate to adjacent segments.

[0049] Examples of manifold segments that can be used in the processes described herein are disclosed in U.S. Patent No. 5,147,542.

[0050] The manifold segment in each filtration module is also fluidly connected to one or more TFF capsules (e.g., one or more separate TFF capsules, one or more TFF capsules packaged in a single capsule holder). For example, the manifold segment can be fluidly connected to TFF capsules through flow channels that connect the feed, permeate and retentate manifolds in the manifold segment to each TFF capsule on the sides of the manifold segment (see, e.g., FIGs. 2B and 2C). Typically, the feed that enters a manifold segment is distributed in a parallel fashion to each of the capsules positioned on the sides of the manifold segment (see, e.g., FIG. 2B).

[0051] The diagrams in FIGs. 2A, 2B and 2C represent side, end and top views, respectively, of a filtration module comprising a single manifold segment 1 and eight TFF capsules 2, with four capsules on each side of the manifold segment. The diagram in FIG. 2A depicts a side view of the manifold segment 1, showing the positions of four capsules 2 on the side that is shown.

[0052] The diagram in FIG. 2B depicts an end view of the same manifold segment 1, showing four capsules 2 on each side of the segment. The feed manifold is depicted using dashed lines. Arrows show the flow path of the feed through the manifold segment. As can be seen in the diagram, the feed is distributed in a parallel fashion to the eight capsules 2.

[0053] The diagram in FIG. 2C depicts a top view of the manifold segment 1 depicted in FIGs. 2A and 2B, showing only the uppermost capsule 2 on each side of the segment. Manifolds within the manifold segment are represented by dashed lines. The circles delineated by dashed lines represent the feed (bottom), permeate (middle) and retentate (top) manifolds in the manifold segment. Horizontal arrows show the flow path out of the feed manifold in the manifold segment and into the capsules on each side, and from the capsules back into the permeate and retentate manifolds in the manifold segment. Vertical arrows show the flow path through the capsules 2 and along the filtration membrane 3 in each capsule.

[0054] The TFF capsules can be located on one or both faces of the manifold segment. Typically, each filtration module can accommodate up to about 10 m² of filtration membrane area on each face of the manifold segment for a total of about 20 m² of area per filtration module. Thus, the total filtration area of a filtration module is about 20 m² or less, such as, for example, about 10 m², about 5 m², about 2 m², about 1 m², about 0.5 m² or about 0.1 m² of filtration membrane area. Accordingly, the number of capsules that can be positioned on each side of the manifold segment depends on the membrane area of the particular capsule. Preferably, the filtration modules in an SPTFF system each contain the same number and arrangement of TFF capsules.

[0055] In one embodiment, TFF capsules (e.g., about 1, 2, 3, 4, 5, 6, 7, 8, 9, 10 or more TFF capsules) are located on both faces of the manifold segment. In another embodiment, TFF capsules (e.g., about 1, 2, 3, 4, 5, 6, 7, 8, 9, 10 or more TFF capsules) are located on only one face of the manifold segment. When TFF capsules are located on both faces of a manifold segment, the number of TFF capsules on each face of the manifold segment can differ or be the same. Preferably, the total number of TFF capsules on each face of the manifold segment is identical. Preferably, each face of the manifold segment has 1, 2, 3, or 4 capsules.

[0056] Exemplary TFF capsules that are useful for the methods described herein include, but are not limited to, TFF capsules supplied by EMD Millipore Corporation (Billerica, MA), such as, for example, Prep/Scale[®] Spiral-Wound Ultrafiltration Modules, Amicon[®] S40 spiral -wound filters, and Helicon SS50 spiral-wound ultrafiltration membrane cartridges. Other spiral filters that are suitable for the methods described herein include, for example, Ultrafiltration Spiral Membranes available from Alfa Laval AB (Lund, Sweden), including, for example, UFX-pHT Series spiral elements with polysulphone membrane. Other examples of suitable capsules and cartridges for use in the methods described herein include, but are not limited to, Process Scale Ultrafiltration Cartridge (UFP-750-E-55A) from GE Healthcare, the BioProducer 24 Green SU XXX 10 PRO 24 S3 from WaterSep Technology Corporation (Marlborough, MA), the hollow fiber KrosFlo[®] modules from Spectrum Labs Inc. (Rancho Dominguez, CA), the Sanitary Ultrafiltration Spiral-Wound Element: VT (PES 3kDa) by Synder Filtration, Inc. (Vacaville, CA), and the ROMICON[™] 6" hollow fiber cartridge by Koch Membrane Systems, Inc. (Wilmington, MA).

[0057] Preferably, the filtration modules in the SPTFF system are stacked (e.g., in a vertical stack) to form levels, wherein each level comprises a single filtration module (see, e.g., FIG. 1). For example, the system can include about 2, 3, 4, 5 or more stacked filtration modules.

[0058] The SPTFF systems used in the methods described herein also include a feed inlet and retentate outlet. In general, the feed inlet is positioned on the first filtration module in the SPTFF system, and is connected on one end to a conduit (e.g., pipe, tube) that is connected to the feed tank and is connected on the other end to the first manifold in the manifold segment in the first module to receive feed into the system. The retentate outlet is typically positioned on

the last, or final, filtration module in the SPTFF system, and is connected on one end to the second manifold in the manifold segment in the last module and is connected on the other end to a conduit (e.g., pipe, channel) that is connected to a retentate container.

[0059] SPTFF systems useful for performing the methods described herein can further contain one or more additional components useful for performing SPTFF processes including, but not limited to, the following, examples of which are known in the art: one or more sampling ports, a T-line (e.g., for in-line buffer addition), a pressure sensor, a diaphragm for a pressure sensor, a valve sensor to indicate whether any valves in the system are open or closed, and a flow meter. In a particular embodiment, the SPTFF system includes a sampling port (e.g., sanitary sampling port) at one or more locations in the system. For example, sampling ports can be included at the end of the retentate line, the permeate line, or both. Typically, the sampling port will be located on the manifold segment in a filtration module. In one embodiment, the SPTFF system lacks diverter plates.

[0060] In some embodiments, one or more components of the SPTFF system can be disposable. Disposable TFF system components are well known and are available commercially. The disposable components are typically made from disposable materials (e.g., plastic, rubber, metal), preferably plastic. Exemplary disposable components for SPTFF and TFF assemblies include, but are not limited to, components of Flexware[®] assemblies for Mobius[®] FlexReady Solution for TFF (EMD Millipore Corporation, Billerica, MA).

Methods of the Invention Using TFF Systems with Recirculation of the Retentate

[0061] In contrast to SPTFF systems of the invention where the liquid feed passes once through the system, the TFF systems of the invention operate by recirculating at least a portion of the retentate back to feed. Accordingly, an embodiment of the invention relates to a method of filtering a liquid feed, comprising passing a liquid feed through a tangential flow filtration (TFF) system, recovering permeate and a portion of the retentate from the system in separate containers without recirculation through the TFF system, and recirculating the remainder of the retentate through the TFF system at least once. Retentate is recirculated during operation of the entire filtration process or at certain times during operation of the filtration process. For example, recirculating all or a portion of the retentate during start up provides a method by which to ensure that system has reached equilibrium and the retentate has achieved the desired concentration prior to collecting it into the product vessel. It also provides a convenient way to respond to system upsets during processing to provide a more robust process. The fraction of retentate that is recirculated can be adjusted via modulation of the pump or control valve as a way to tune the system in order to assure consistent retentate concentration and/ or consistent retentate flow rate to the product collection vessel every run even if feedstock protein concentration, new membrane permeability, membrane fouling, membrane permeability, or membrane mass transfer or pressure drop varies from batch to batch. This strategy has particular benefits in the context of continuous processing where the success of

subsequent operations relies on the output of a previous operation. Recirculation of retentate can improve cleaning effectiveness through increased cross flow velocity and reduce cleaning solution through recirculation.

[0062] The TFF systems employed in the TFF methods of the invention involving recirculation additionally include a recirculation loop or at least one pump or control valve for recirculating retentate through all or part of the system and at least one conduit for recirculating (e.g., carrying) retentate.

[0063] Typically, at least about 50% of the retentate is collected after a single pass, while the remainder of the retentate is recirculated. Preferably, about 10% or less (e.g., about 0.5%, about 1%, about 2%, about 5%, about 10%) of the retentate is recirculated after the first pass through the TFF system.

[0064] The amount of retentate that is recirculated can be controlled using, for example, a pump or a valve. A flow meter can be used to provide a process value for the pump or valve to control the amount of retentate that is recirculated. Preferably, the valve or pump and/or flow meter is/are positioned on the retentate outlet or flow line carrying retentate out of the system to the retentate receptacle.

[0065] The retentate that is being recirculated can be returned to any upstream location in or before the TFF system. In one embodiment, the retentate is recirculated to the feed tank. In another embodiment, the retentate is recirculated to the feed line near the feed pump before the feed inlet on the TFF system.

[0066] An example TFF system configured for recirculation of the retentate is shown in FIG. 3, where the number of filtration modules 5 arranged in series (see also FIG. 1 for an example configuration) can differ depending upon system design. Feed enters the system at the left through a feed inlet 6 and a portion of the retentate is recirculated back to feed through recirculation line 16. Retentate and permeate exit the system through retentate 4 and permeate outlets 13. In an alternative configuration (not shown), the recirculation pump can be in the retentate recirculation line 16.

[0067] The systems and methods described herein with regard to SPTFF are applicable to TFF systems and methods.

Methods of the Invention Employing Diafiltration

[0068] In some embodiments, the methods described herein further comprise performing diafiltration (e.g., to remove or lower the concentration of salts or solvents in the liquid feed, or to accomplish buffer exchange). In a preferred embodiment, the diafiltration is performed by concentrating the liquid feed (e.g., by SPTFF or TFF) to reduce the diafiltration volume and then restoring the feed to its starting volume by adding diafiltration solution (e.g., diafiltration

buffer), a process which is known in the art as discontinuous, or batch, diafiltration. In another embodiment, diafiltration is performed by adding the diafiltrate solution to retentate to increase the diafiltration volume followed by concentrating the sample to restore it to its original volume. In yet another embodiment, the diafiltration is performed by adding the diafiltration solution to unfiltered feed at the same rate that permeate is removed from the SPTFF or TFF system, a process which is known in the art as continuous, or constant-volume, diafiltration. Continuous countercurrent diafiltration can be performed with the TFF systems and methods of the invention. Suitable diafiltration solutions are well known and include, for example, water and various aqueous buffer solutions.

[0069] To perform diafiltration, the TFF system can include a reservoir or container for diafiltration solution and one or more conduits for carrying diafiltration solution from the diafiltration solution container to the liquid feed tank.

[0070] To avoid extremes of concentration and in-line dilution as part of the diafiltration process (e.g. >90%), it is preferred to inject the diafiltrate into multiple sections of the filtration assembly to restore the flow in the retentate section to the same flow as in the initial feed. This requires matching the rate of diafiltrate buffer addition with the rate of permeate removal. A preferred method is to use a single pump with multiple pump heads containing the diafiltrate addition and permeate removal flow lines (e.g. peristaltic pump from Ismatec (Glattbrugg, Switzerland)). Each pump head will have closely-matched pumping rates so this process will be balanced and maintain efficient buffer exchange. It is recommended to match flows for each of the multiple sections by using pumps containing up to 24 channels. The diafiltrate can be injected into the retentate ports in manifolds or separator plates.

[0071] While this invention has been particularly shown and described with references to example embodiments thereof, it will be understood by those skilled in the art that various changes in form and details may be made therein without departing from the scope of the invention encompassed by the appended claims.

REFERENCES CITED IN THE DESCRIPTION

Cited references

This list of references cited by the applicant is for the reader's convenience only. It does not form part of the European patent document. Even though great care has been taken in compiling the references, errors or omissions cannot be excluded and the EPO disclaims all liability in this regard.

Patent documents cited in the description

- WO2007076496A2 [0002]
- US2003066794A1 [0002]
- US5147542A [0049]

PATENTKRAV

1. Fremgangsmåde til filtrering af en flydende tilførsel, og som omfatter:

a) føring af en flydende tilførsel gennem et enkelt passage, tangentielt strømningfiltrerings- (SPTFF) system, der omfatter:

5 en flerhed af filtreringsmoduler (5), der er fluidforbundne, hvor hvert filtreringsmodul (5) omfatter:

et fordelersegment (1), der omfatter en første fordeler til modtagelse og føring af tilførslen ind i filtreringsmodulet (5), en anden fordeler til modtagelse og føring af retentat ud af filtreringsmodulet (5) og en tredje fordeler til modtagelse og føring af permeat gennem filtreringsmodulet (5); og

10 én eller flere TFF-kapsler (2) der er placeret på én eller flere flader af, og er fluidforbundet med, fordelersegmentet (1);

hvor hvert filtreringsmodul (5) har et samlet filtreringsområde på ca. 20 m² eller mindre;

15 et tilførselsindløb (6) på det første filtreringsmodul (5) i systemet;

et retentatudløb (4) på det sidste filtreringsmodul (5) i systemet og

ventiler placeret i de første og anden fordelere, hvor ventilerne muliggør parallel strømning mellem fordelersegmenter, når ventilerne er åbne, og seriel strømning mellem fordelersegmenter, når ventilerne er lukkede,

20 hvor SPTFF-systemet har en væskestrømningsbane, der er parallel ind i kapslerne (2) i hvert filtreringsmodul (5) og seriel gennem fordelersegmenterne (1) i tilstødende filtreringsmoduler (5) ved kobling af den første fordeler i hvert fordelersegment (1) til den anden fordeler i et tilstødende fordelersegment (1), således at retentatet fra ét modul (5) fungerer som tilførslen til fordelersegmentet (1) i det næste filtreringsmodul (5), bortset fra at den første fordeler i

25 (1) i det næste filtreringsmodul (5), bortset fra at den første fordeler i fordelersegmentet (1) i det første filtreringsmodul (5) i systemet er forbundet med tilførselsindløbet (6), og

den anden fordeler i fordelersegmentet (1) i det sidste filtreringsmodul (5) i systemet er forbundet med retentatudløbet (4); og

b) genvinding af retentatet og permeatet fra systemet i separate beholdere uden recirkulation gennem SPTFF-systemet,

hvorved væsketilførslen filtreres.

2. Fremgangsmåde til filtrering af en flydende tilførsel, og som omfatter:

5 a) føring af en flydende tilførsel gennem et tangentielt strømningfiltrerings- (TFF) system, der omfatter:

en flerhed af filtreringsmoduler (5) der er fluidforbundne, hvor hvert filtreringsmodul (5) omfatter:

10 et fordelersegment (1), der omfatter en første fordeler til modtagelse og føring af tilførslen ind i filtreringsmodulet (5), en anden fordeler til modtagelse og føring af retentat ud af filtreringsmodulet (5) og en tredje fordeler til modtagelse og føring af permeat gennem filtreringsmodulet (5); og

én eller flere TFF-kapsler (2), der er placeret på én eller flere flader af, og er fluidforbundet med, fordelersegmentet (1);

15 hvor hvert filtreringsmodul (5) har et samlet filtreringsområde på ca. 20 m² eller mindre;

et tilførselsindløb (6) på det første filtreringsmodul (5) i systemet;

et retentatudløb (4) på det sidste filtreringsmodul (5) i systemet;

20 en recirkulationssløjfe (16) til recirkulation af retentat gennem hele eller en del af systemet;

mindst én ledning til recirkulation af retentat og

ventiler placeret i de første og anden fordelere, hvor ventilerne muliggør parallel strømning mellem fordelersegmenter, når ventilerne er åbne, og seriel strømning mellem fordelersegmenter, når ventilerne er lukkede,

25 hvor TFF-systemet har en væskestrømningsbane, der er parallel ind i kapslerne (2) i hvert filtreringsmodul (5) og seriel gennem fordelersegmenterne (1) i tilstødende filtreringsmoduler (5) ved kobling af den første fordeler i hvert fordelersegment (1) til den anden fordeler af et tilstødende fordelersegment (1), således at retentatet fra ét modul (5) fungerer som tilførslen til fordelersegmentet

(1) i det næste filtreringsmodul (5), bortset fra at den første fordeler i fordelersegmentet (1) i det første filtreringsmodul (5) i systemet er forbundet med tilførselsindløbet (6), og den anden fordeler i fordelersegmentet (1) i det sidste filtreringsmodul (5) i systemet er forbundet med retentatudløbet (4); og

5 b) genvinding af permeat i en permeatbeholder og en del af retentatet fra systemet i en retentatbeholder uden recirkulation gennem TFF-systemet og

 c) recirkulation af det resterende af retentatet gennem hele eller en del af TFF-systemet mindst én gang, hvorved væsketilførslen filtreres.

3. Fremgangsmåde ifølge krav 1 eller krav 2, hvor filtreringsområdet for hvert
10 filtreringsmodul (5) er ca. 20 m², ca. 10 m², ca. 5 m², ca. 2 m², ca. 1 m², ca. 0,5 m² eller ca. 0,1 m².

4. Fremgangsmåde ifølge krav 1 eller krav 2, og som endvidere omfatter et diafiltreringstrin, hvor diafiltreringstrinnet indbefatter opkoncentrerings- og fortyndingstrin.

15 **5.** Fremgangsmåde ifølge krav 1, hvor SPTFF-systemet endvidere omfatter en diafiltreringsopløsningsbeholder til diafiltreringsopløsning og en ledning til levering af diafiltreringsopløsning til en tilførselsbeholder.

6. Fremgangsmåde ifølge krav 1, hvor SPTFF-systemet endvidere omfatter én eller flere af: prøveudtagningsport, en T-ledning til inline-buffertilsætning, en
20 tryksensor, en membran til en tryksensor.

7. Fremgangsmåde ifølge krav 1, hvor SPTFF-systemet mangler afledningsplader.

8. Fremgangsmåde ifølge krav 1, hvor SPTFF-systemet indbefatter en diafiltratopløsningspumpe med flere pumpehoveder, der hvert indeholder
25 diafiltratopløsningsstilsætnings- og permeatfjernelsesstrømningsledninger.

9. Fremgangsmåde ifølge krav 1, hvor fordelerne i fordelersegmentet (1) har den samme diameter gennem filtreringssystemet, eller fordelerne i fordelersegmentet (1) har progressivt mindre diametre fra fordelersegment (1) til fordelersegment (1).

10. Fremgangsmåde ifølge krav 2, hvor ca. 10 % eller mindre af retentatet recirkuleres efter den første føring gennem TFF-systemet.

11. Fremgangsmåde ifølge krav 2, hvor TFF-systemet indbefatter en ventil eller en flowmåler, der er placeret på retentatudløbet eller ledningen, der fører
5 retentat fra systemet till retentatbeholderen, for at styre mængden af retentat, der recirkuleres.

12. Fremgangsmåde ifølge krav 2, hvor retentat recirkuleres tilbage til tilførselsbeholderen eller tilbage til tilførselsledningen efter en tilførselspumpe.

13. Fremgangsmåde ifølge krav 2, hvor TFF-systemet endvidere omfatter én
10 eller flere af: prøveudtagningsport, en T-ledning til inline-buffertilslætning, en tryksensor, en membran til en tryksensor, en diafiltreringsopløsningsbeholder til diafiltreringsopløsning og en ledning til levering af diafiltreringsopløsning til en tilførselsbeholder.

14. Fremgangsmåde ifølge krav 2, hvor TFF-systemet mangler
15 afledningsplader.

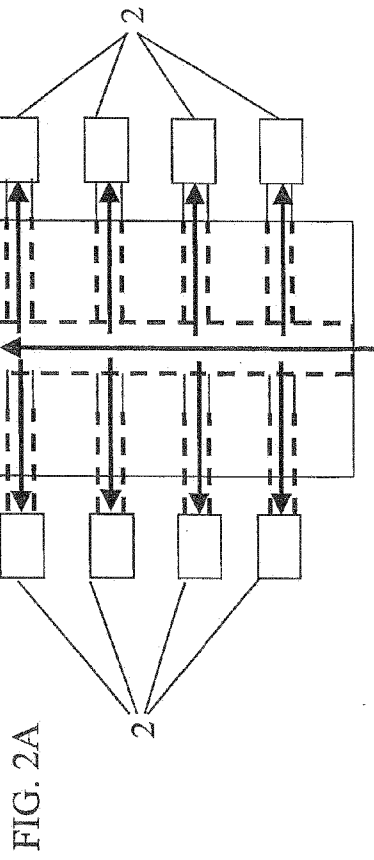
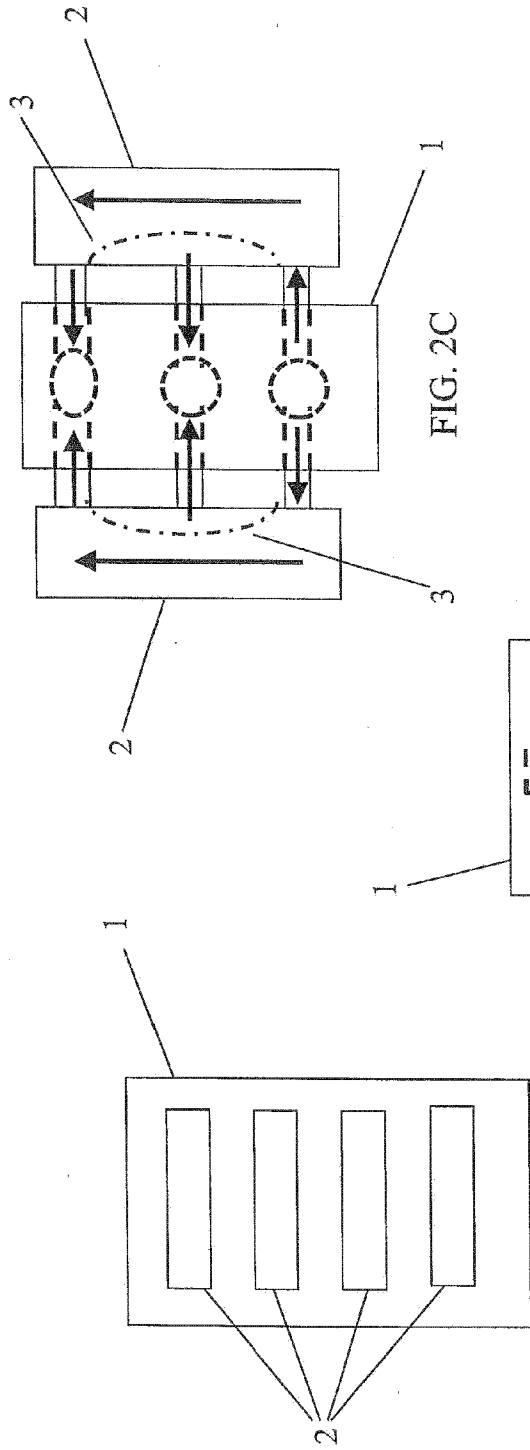

FIG. 2B

FIG. 2A

FIG. 2C

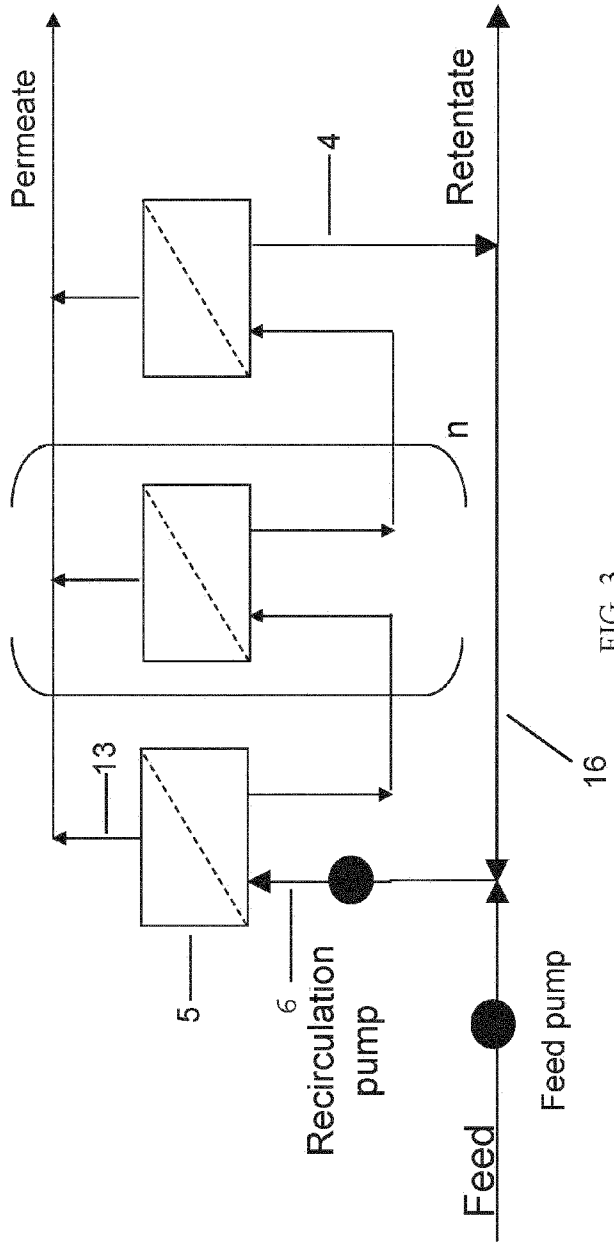

FIG. 3