

(12) **United States Patent**
Osada et al.

(10) **Patent No.:** **US 10,490,986 B2**
(45) **Date of Patent:** **Nov. 26, 2019**

(54) **METHOD OF MANUFACTURING BRANCH PROTECTOR AND METHOD OF MANUFACTURING WIRE HARNESS**

USPC 704/72 A
See application file for complete search history.

(71) Applicant: **Yazaki Corporation**, Tokyo (JP)

(56) **References Cited**

(72) Inventors: **Yasumasa Osada**, Shizuoka (JP);
Fumihiko Kitamura, Shizuoka (JP)

U.S. PATENT DOCUMENTS

(73) Assignee: **YAZAKI CORPORATION**,
Minato-ku, Tokyo (JP)

- 5,338,014 A * 8/1994 Kitamura H01B 13/01209
269/254 CS
2005/0037665 A1* 2/2005 Konda H01R 13/025
439/607.01
2012/0261184 A1* 10/2012 Kitamura B60R 16/0215
174/72 A
2013/0269970 A1* 10/2013 Hara B60R 16/0215
174/101
2016/0156165 A1* 6/2016 Katou H01B 7/0045
174/72 A

(*) Notice: Subject to any disclaimer, the term of this patent is extended or adjusted under 35 U.S.C. 154(b) by 0 days.

(21) Appl. No.: **16/019,834**

FOREIGN PATENT DOCUMENTS

(22) Filed: **Jun. 27, 2018**

- JP 2009077517 * 4/2009
JP 2012253961 A * 12/2012
JP 5217873 B2 6/2013
JP 2013225981 * 10/2013
JP 2013225981 A * 10/2013

(65) **Prior Publication Data**

US 2019/0013655 A1 Jan. 10, 2019

(30) **Foreign Application Priority Data**

Jul. 7, 2017 (JP) 2017-133568

* cited by examiner

Primary Examiner — Timothy J Thompson

Assistant Examiner — Charles Pizzuto

(74) *Attorney, Agent, or Firm* — Sughrue Mion, PLLC

(51) **Int. Cl.**

H02G 3/04 (2006.01)
B60R 16/02 (2006.01)
H02G 3/06 (2006.01)

(57) **ABSTRACT**

A method of manufacturing a branch protector includes a component setting step of supporting a protector sheet of a branch protector in a floating state from a jig base on a jig pin erected on the jig base, and an assembling step of assembling a wire branch portion to the protector sheet.

(52) **U.S. Cl.**

CPC **H02G 3/0468** (2013.01); **B60R 16/0215** (2013.01); **H02G 3/0691** (2013.01)

(58) **Field of Classification Search**

CPC . H02G 3/0468; H02G 3/0691; B60R 16/0215

11 Claims, 88 Drawing Sheets

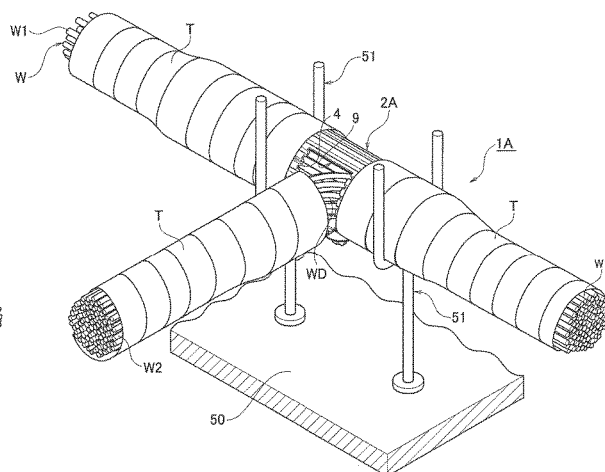
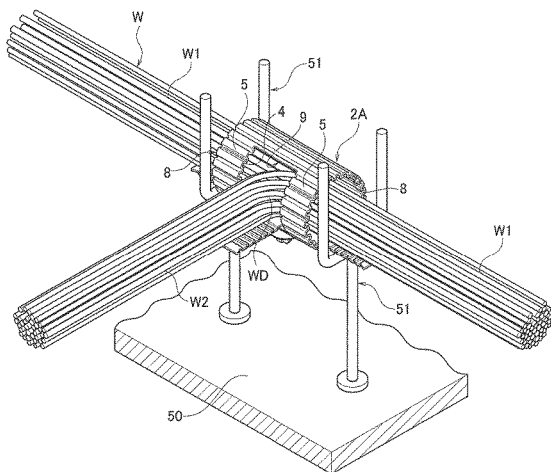


FIG. 1 PRIOR ART

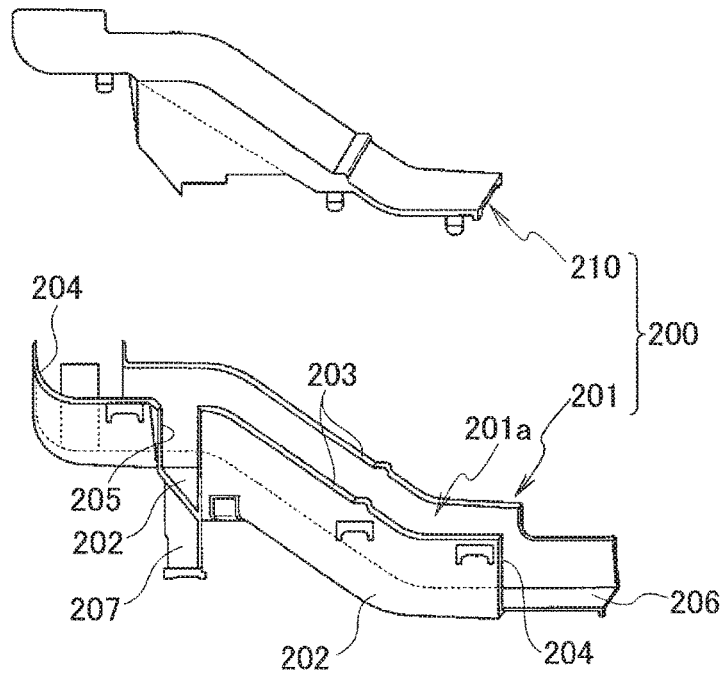


FIG. 2 PRIOR ART

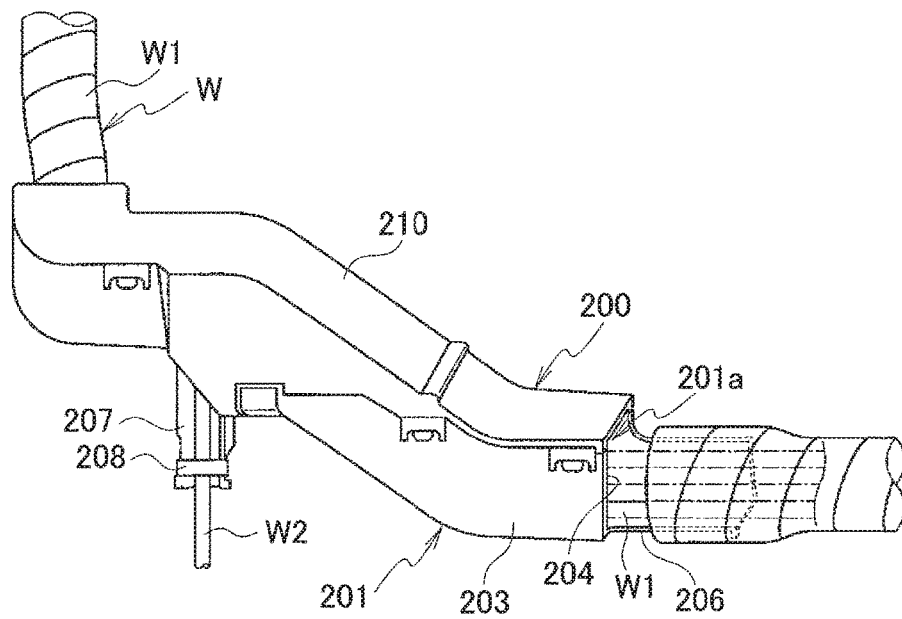
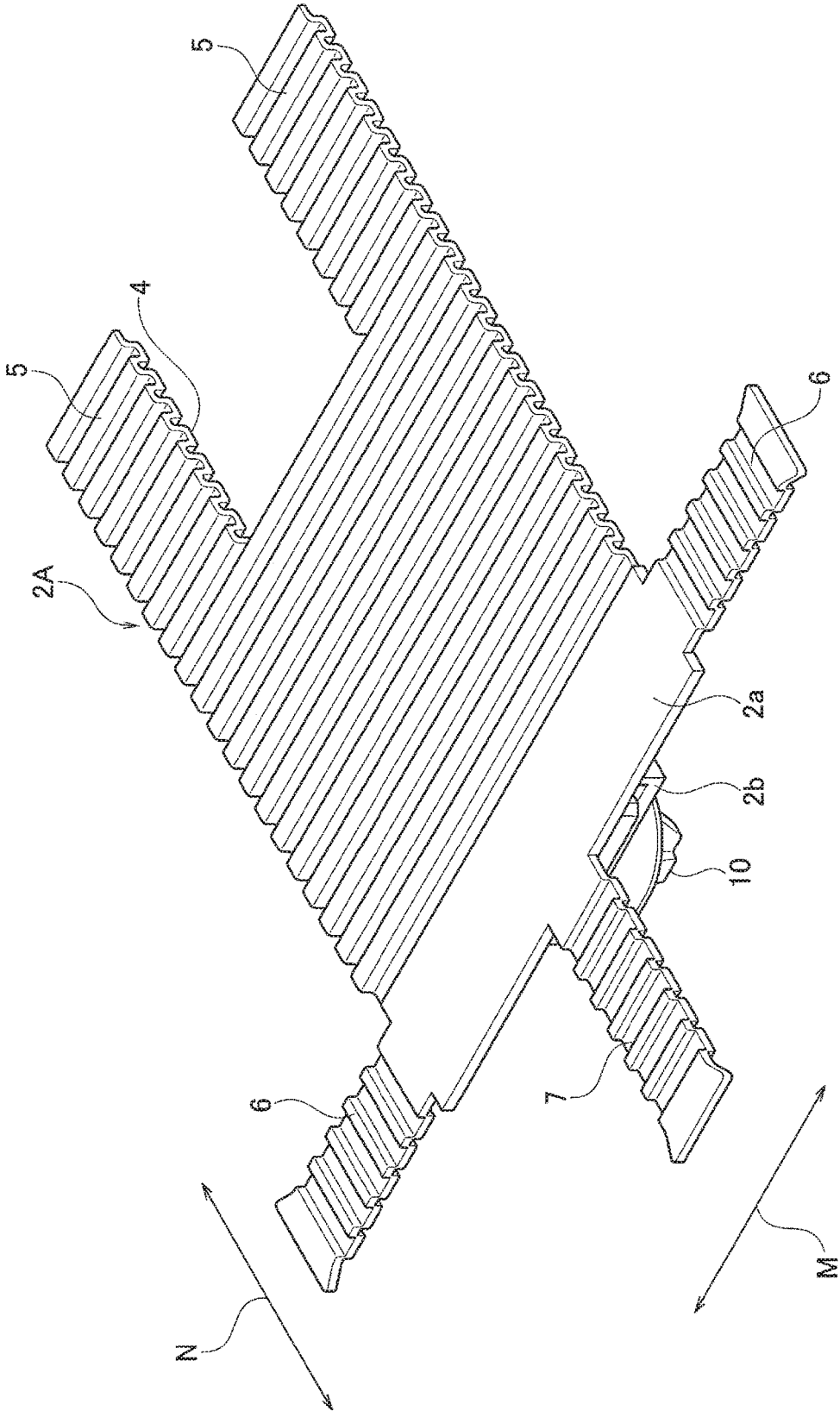


FIG. 3



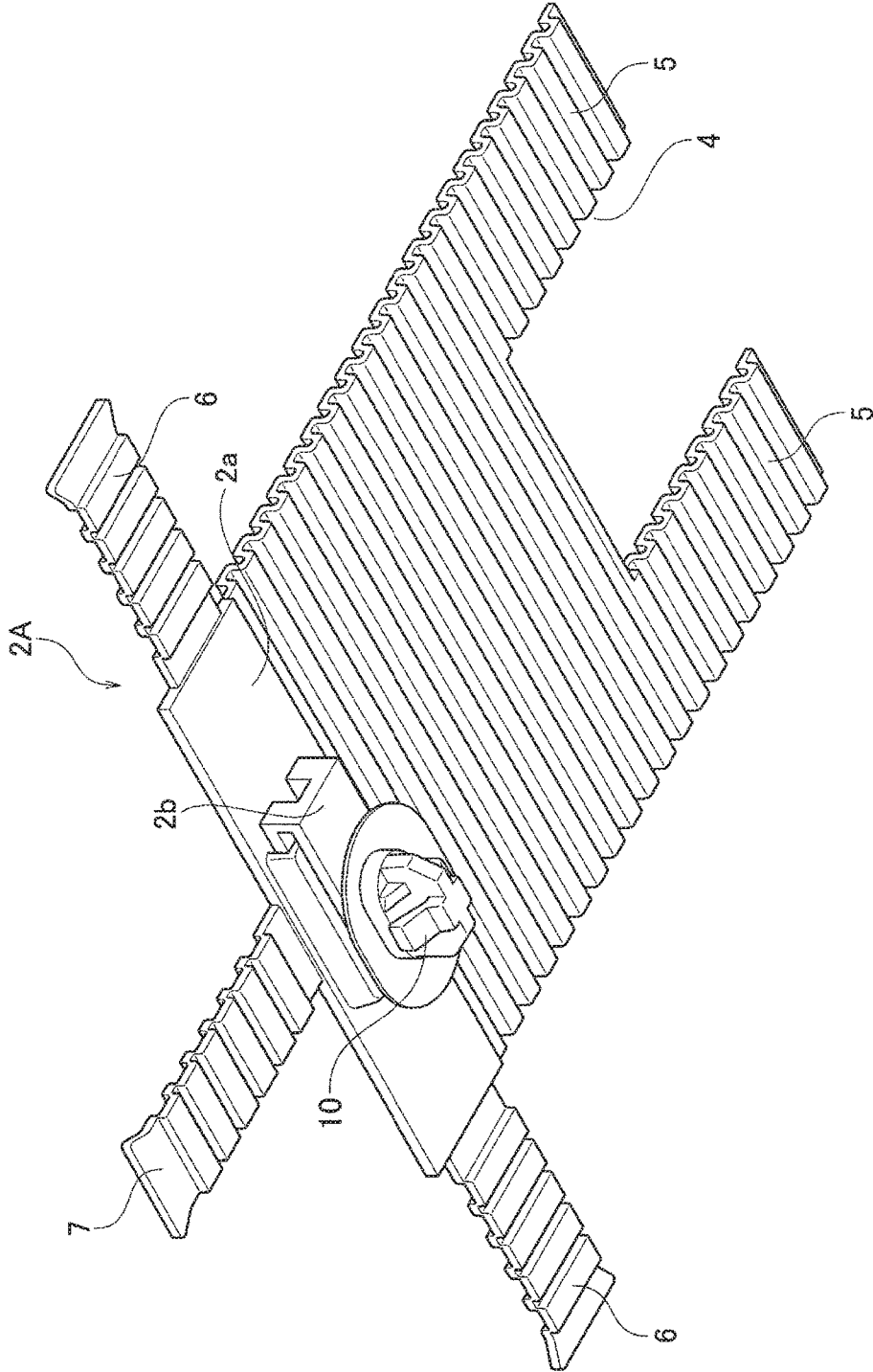


FIG. 4

FIG. 5

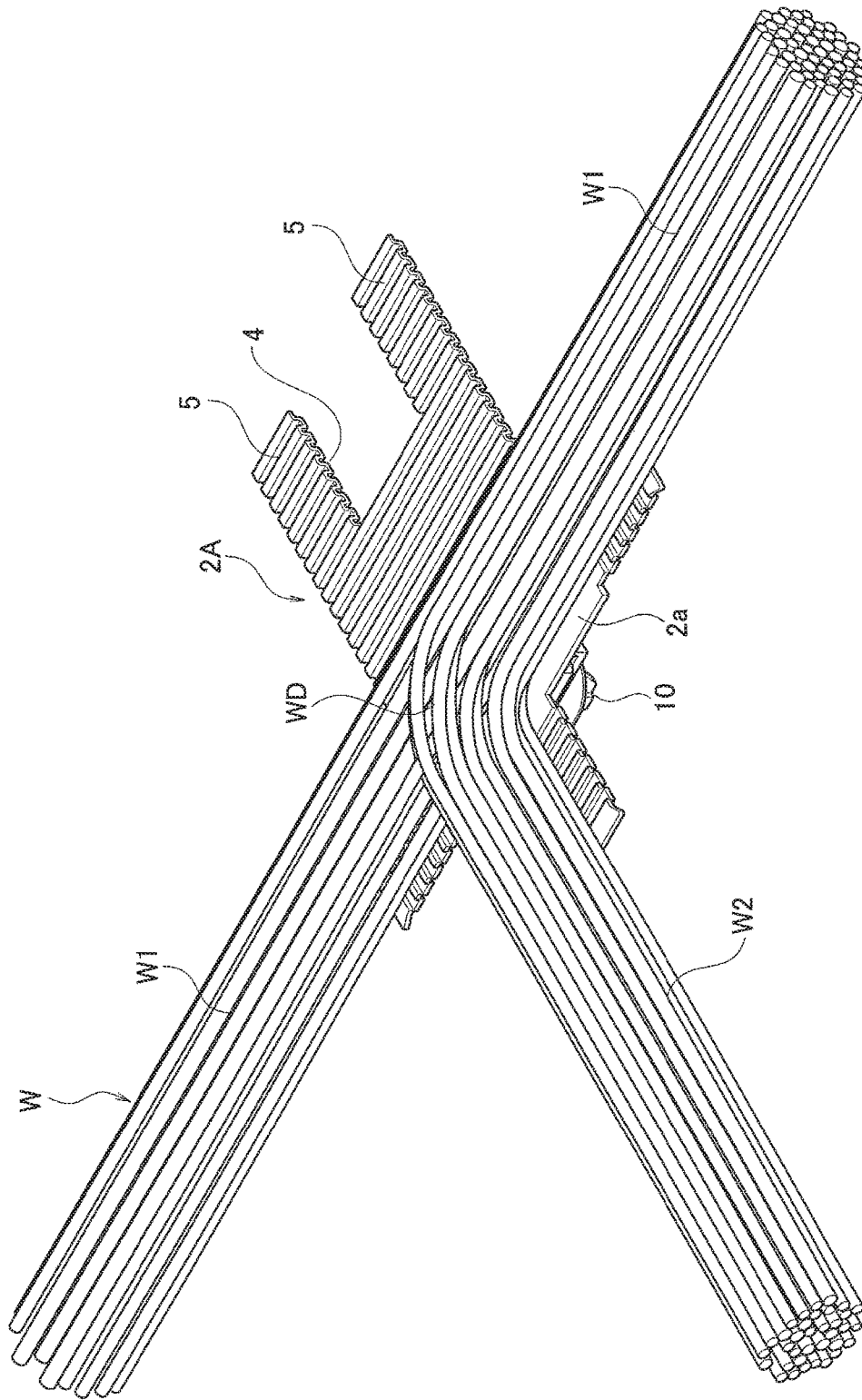


FIG. 6A

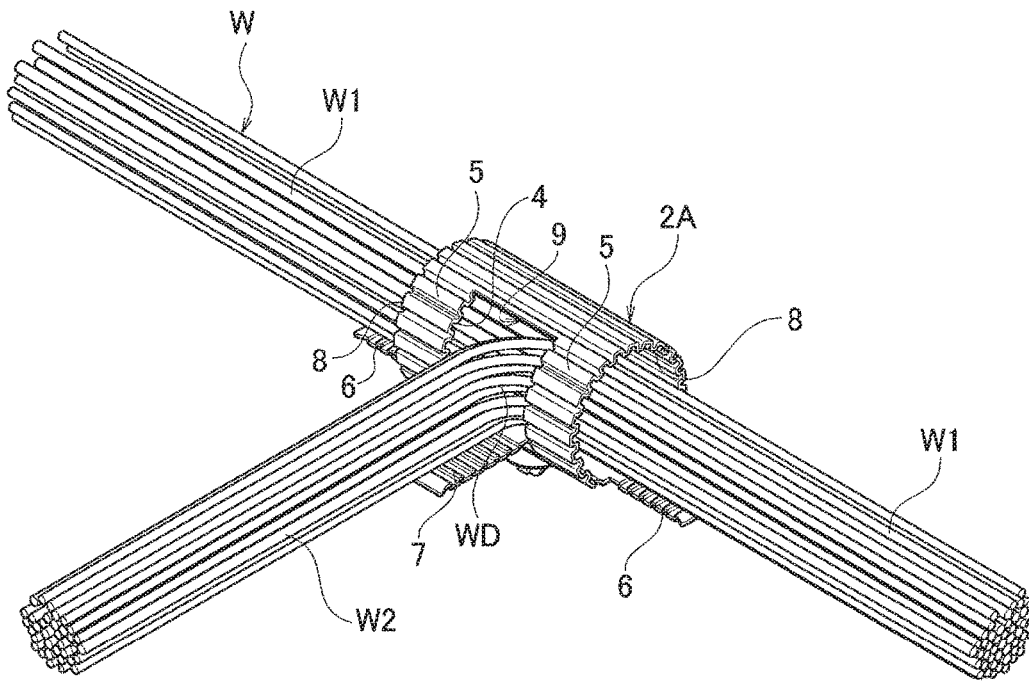
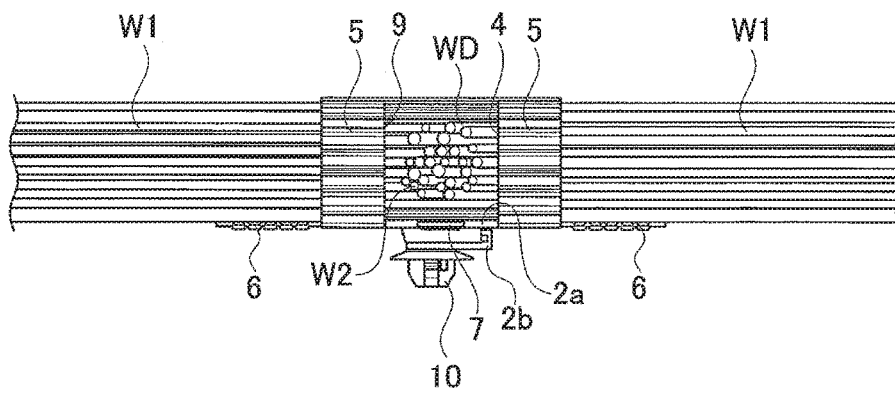


FIG. 6B



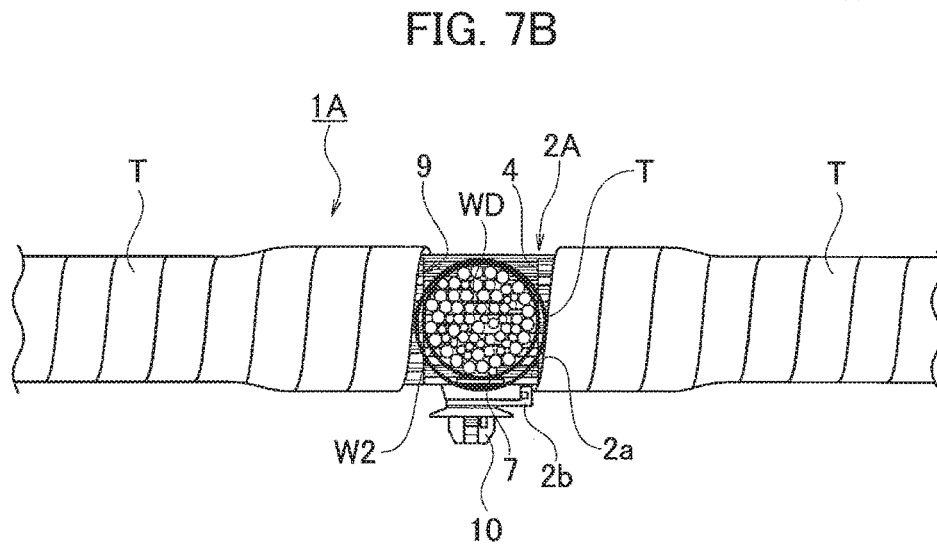
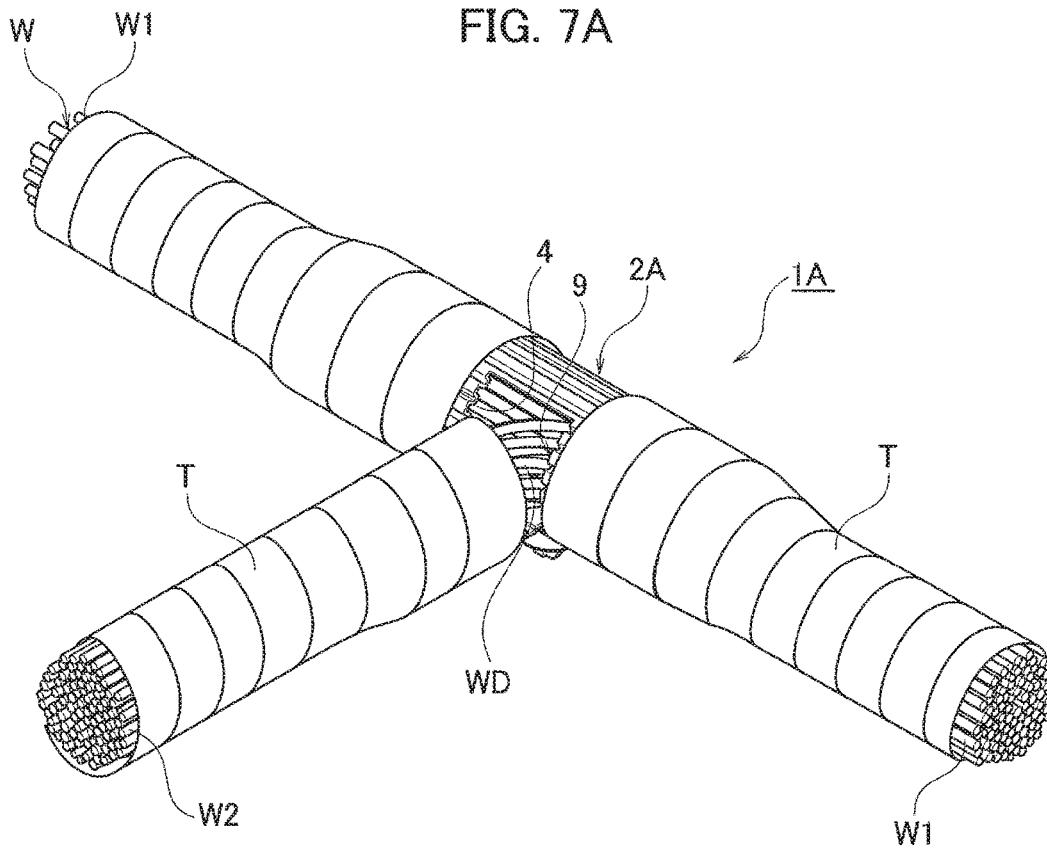


FIG. 8

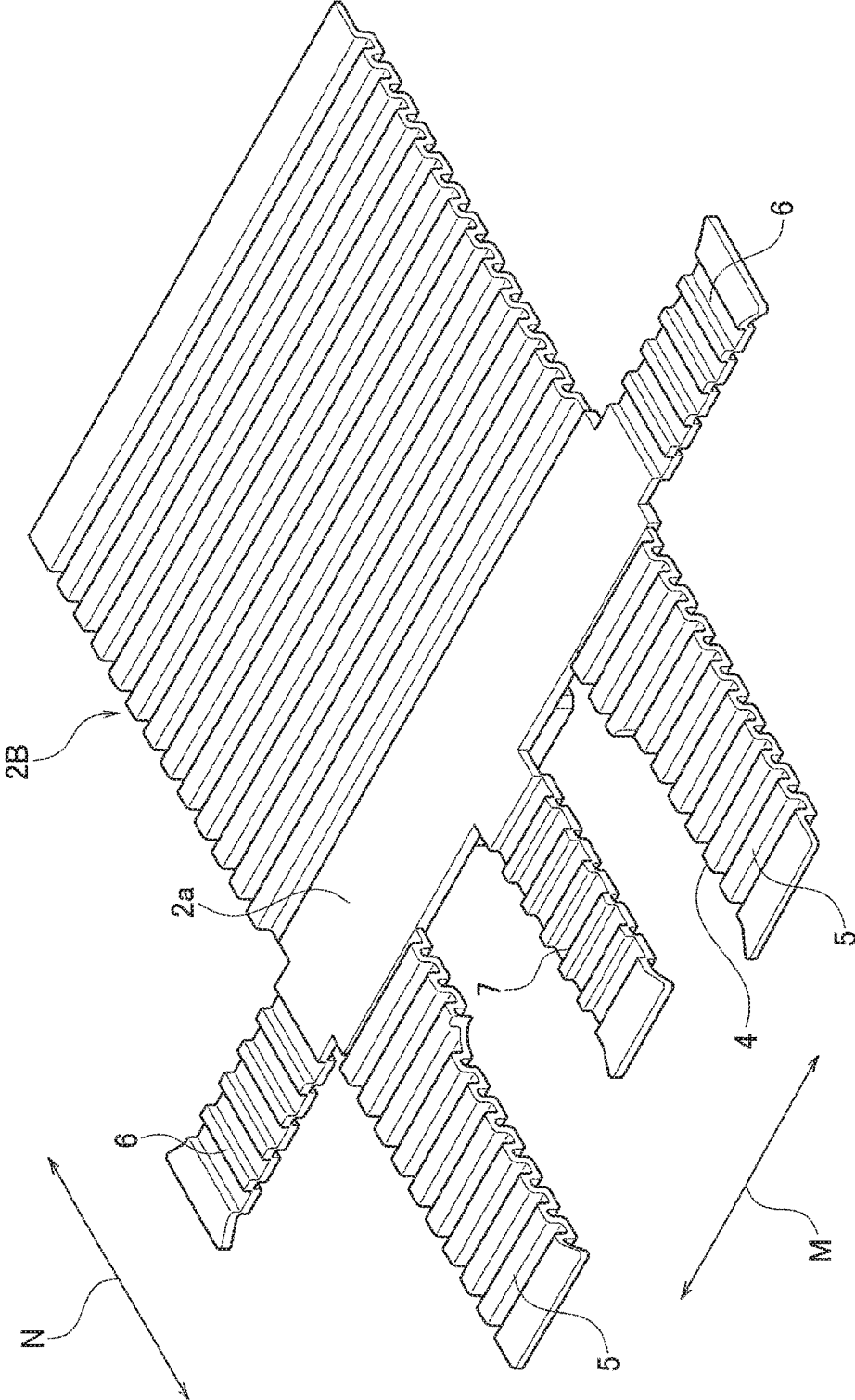


FIG. 11

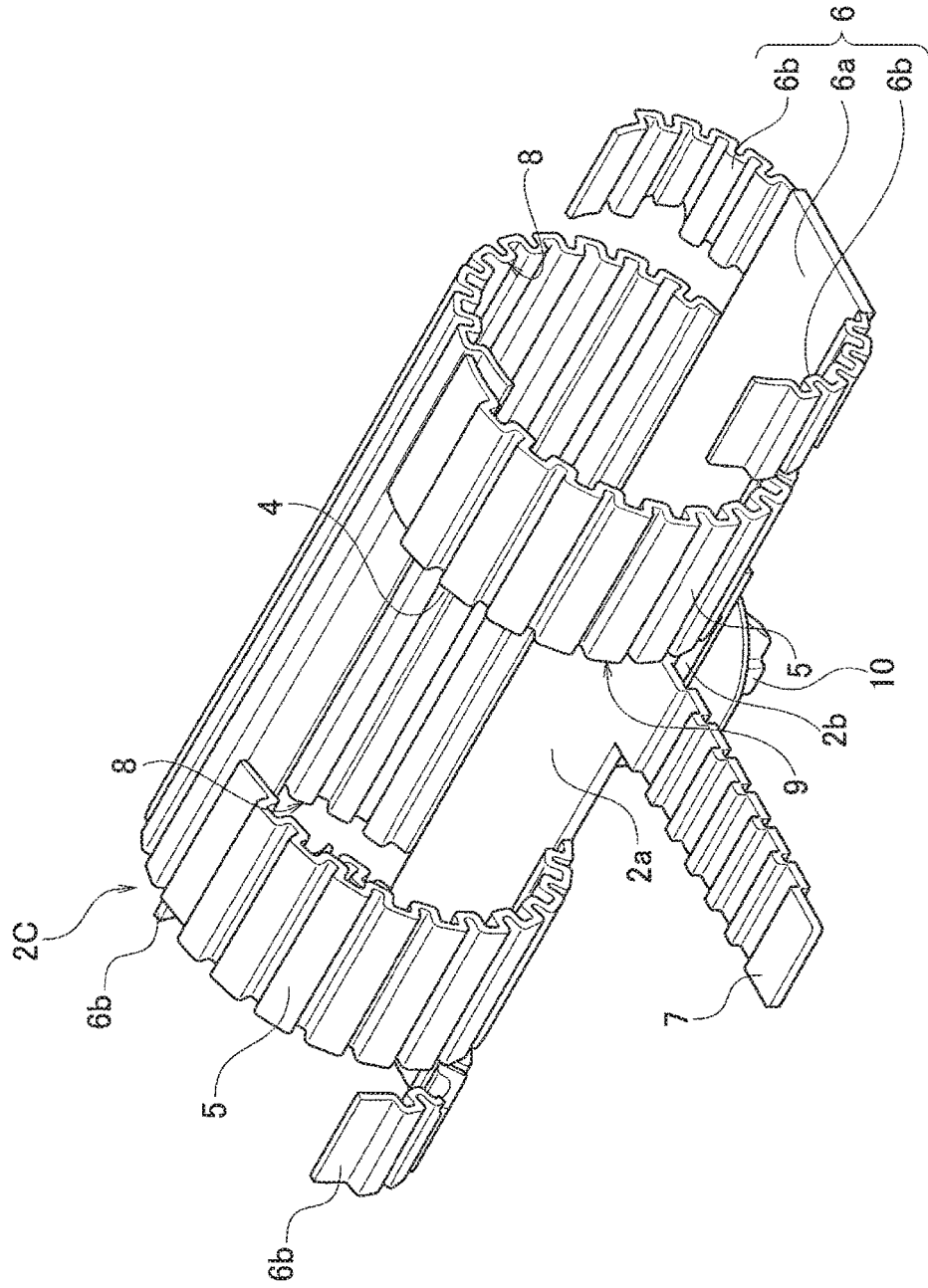


FIG. 12

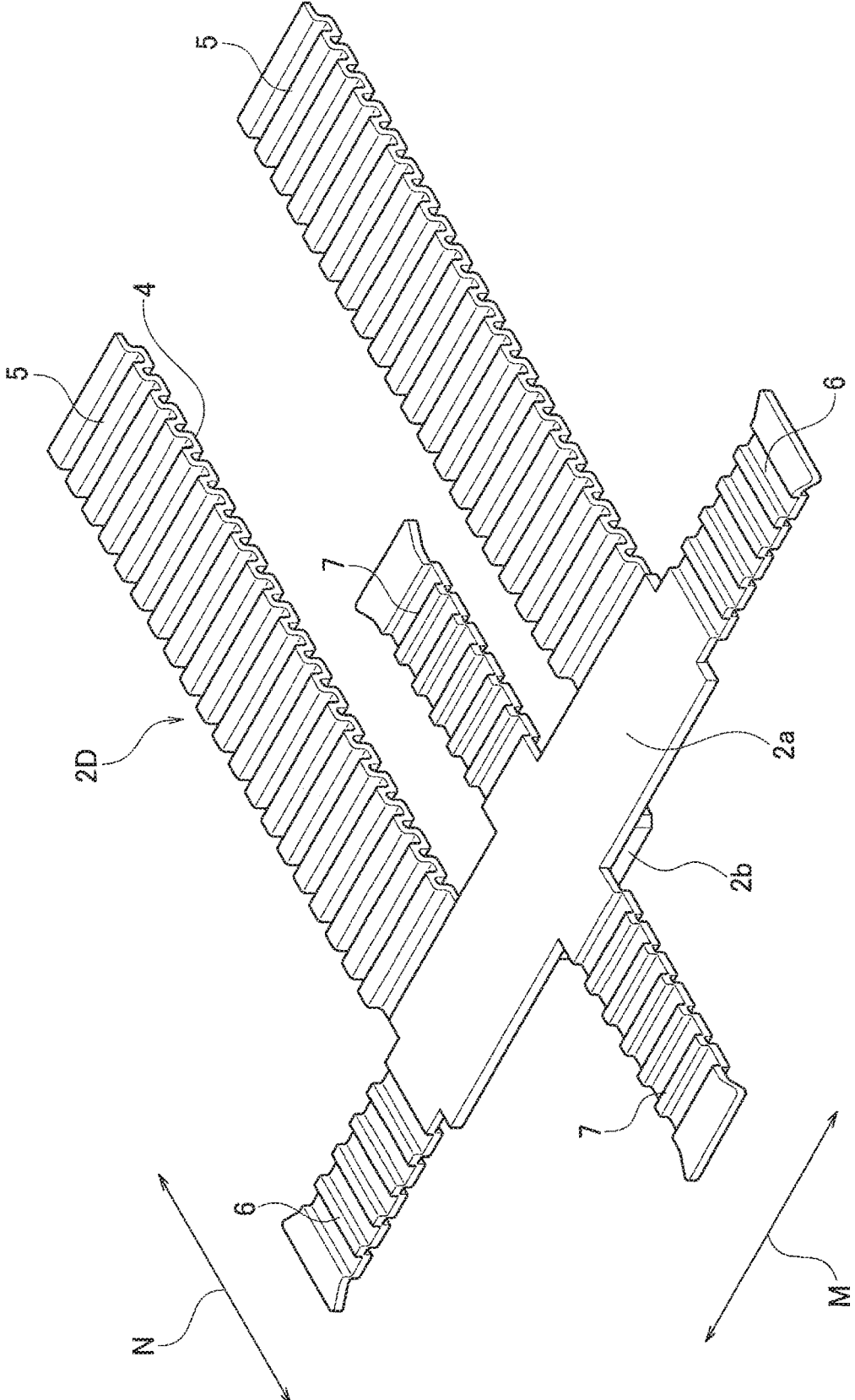


FIG. 13

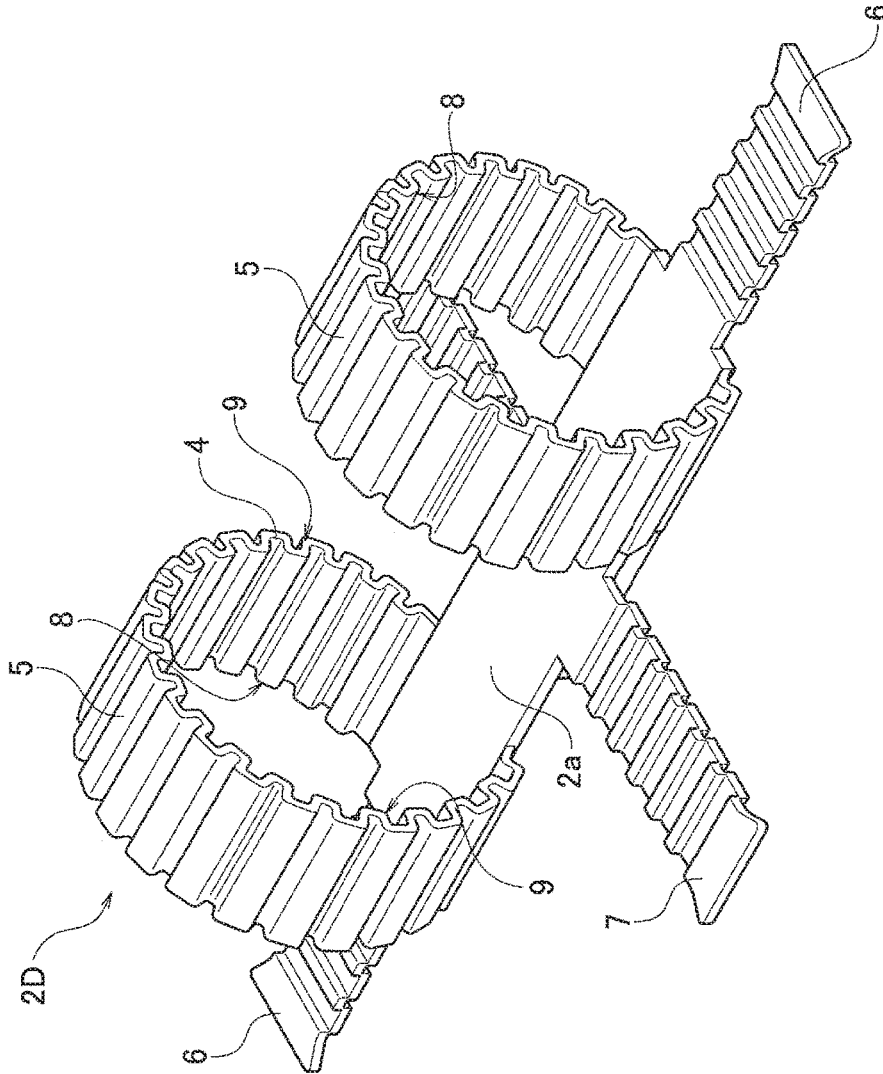


FIG. 15

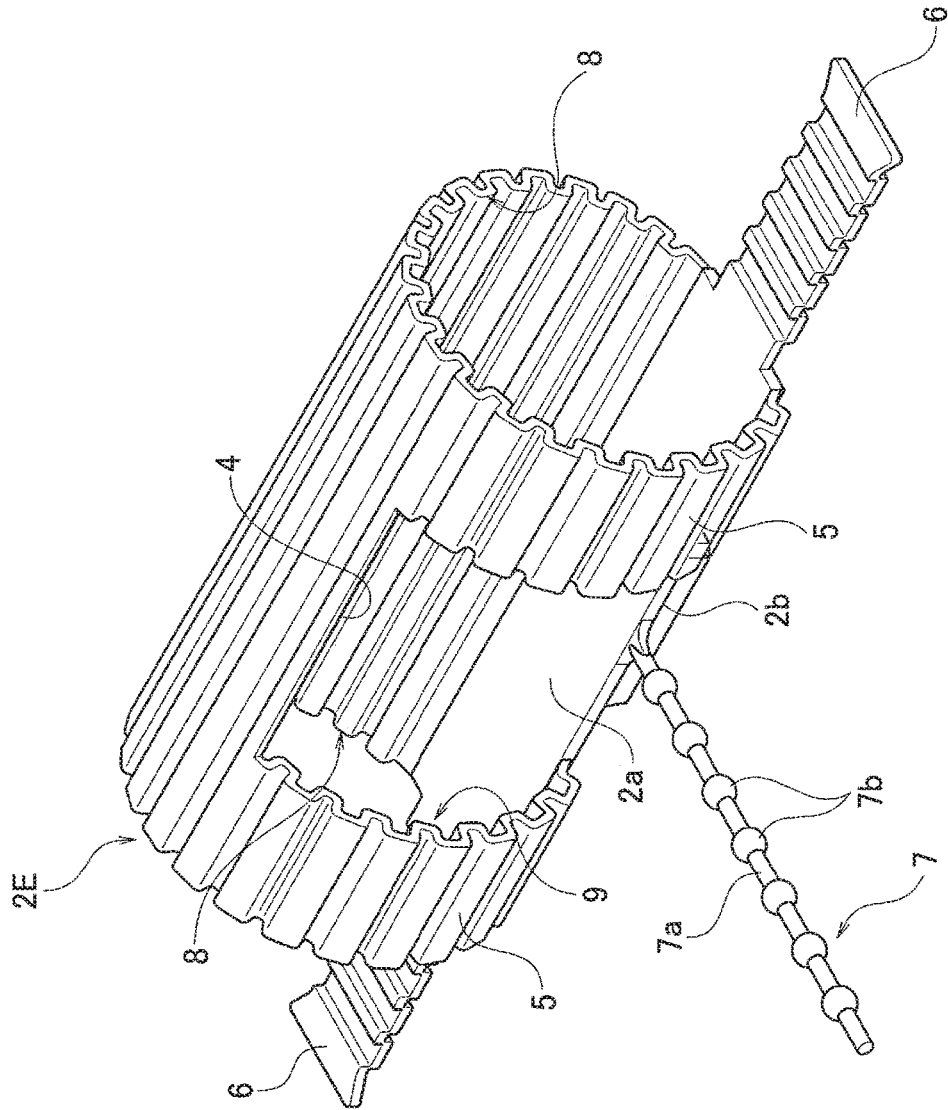


FIG. 16

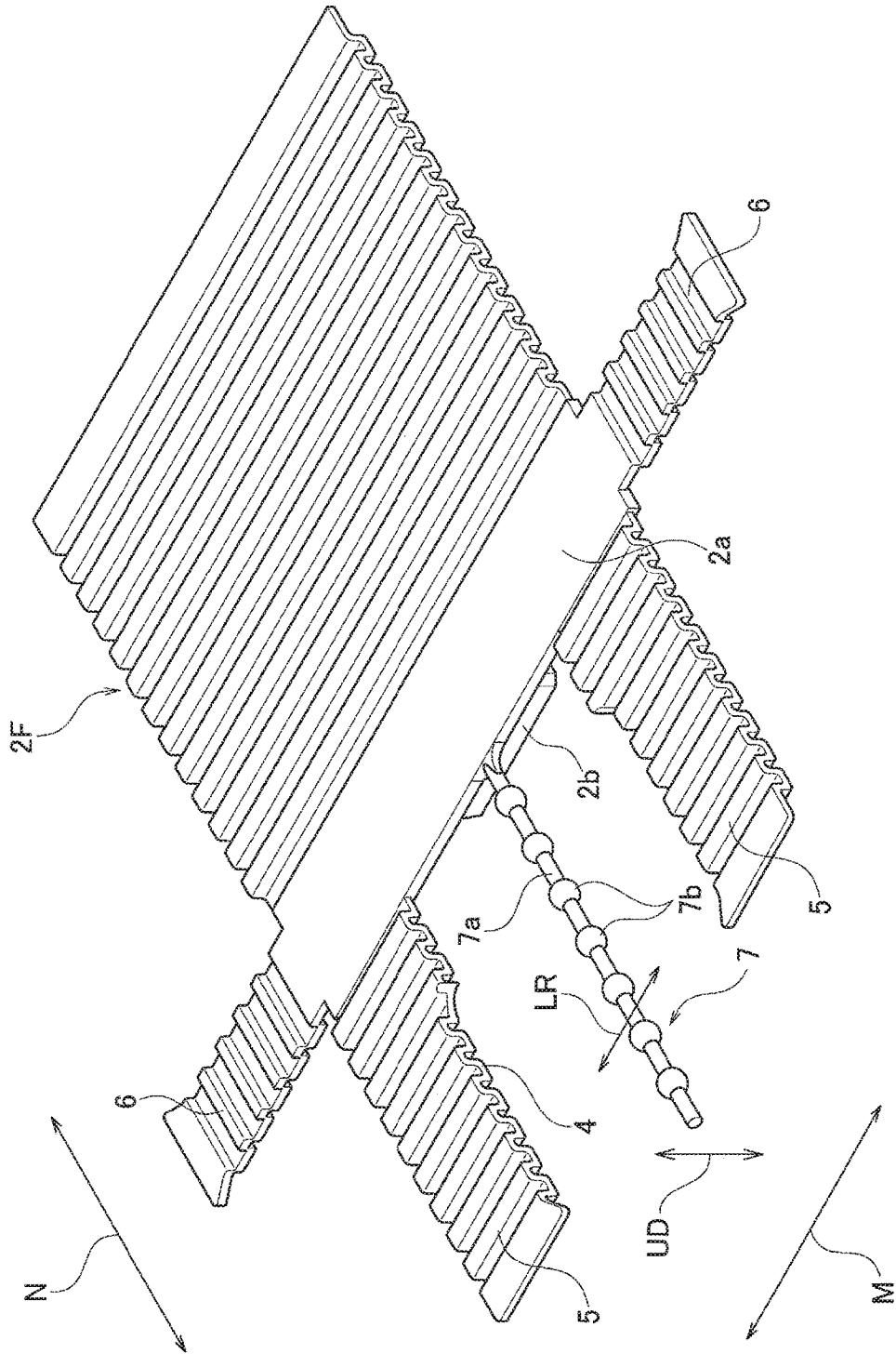


FIG. 17

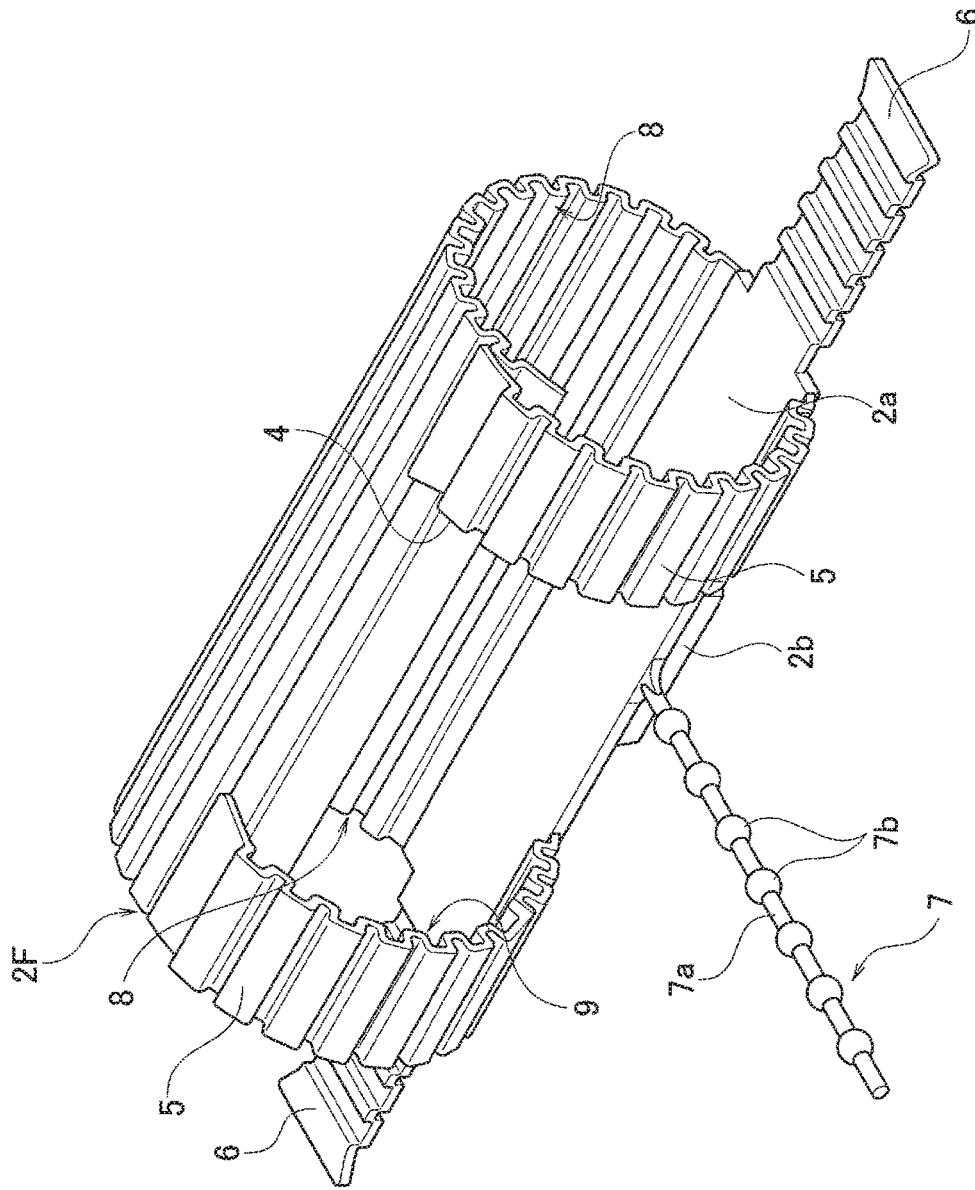


FIG. 18

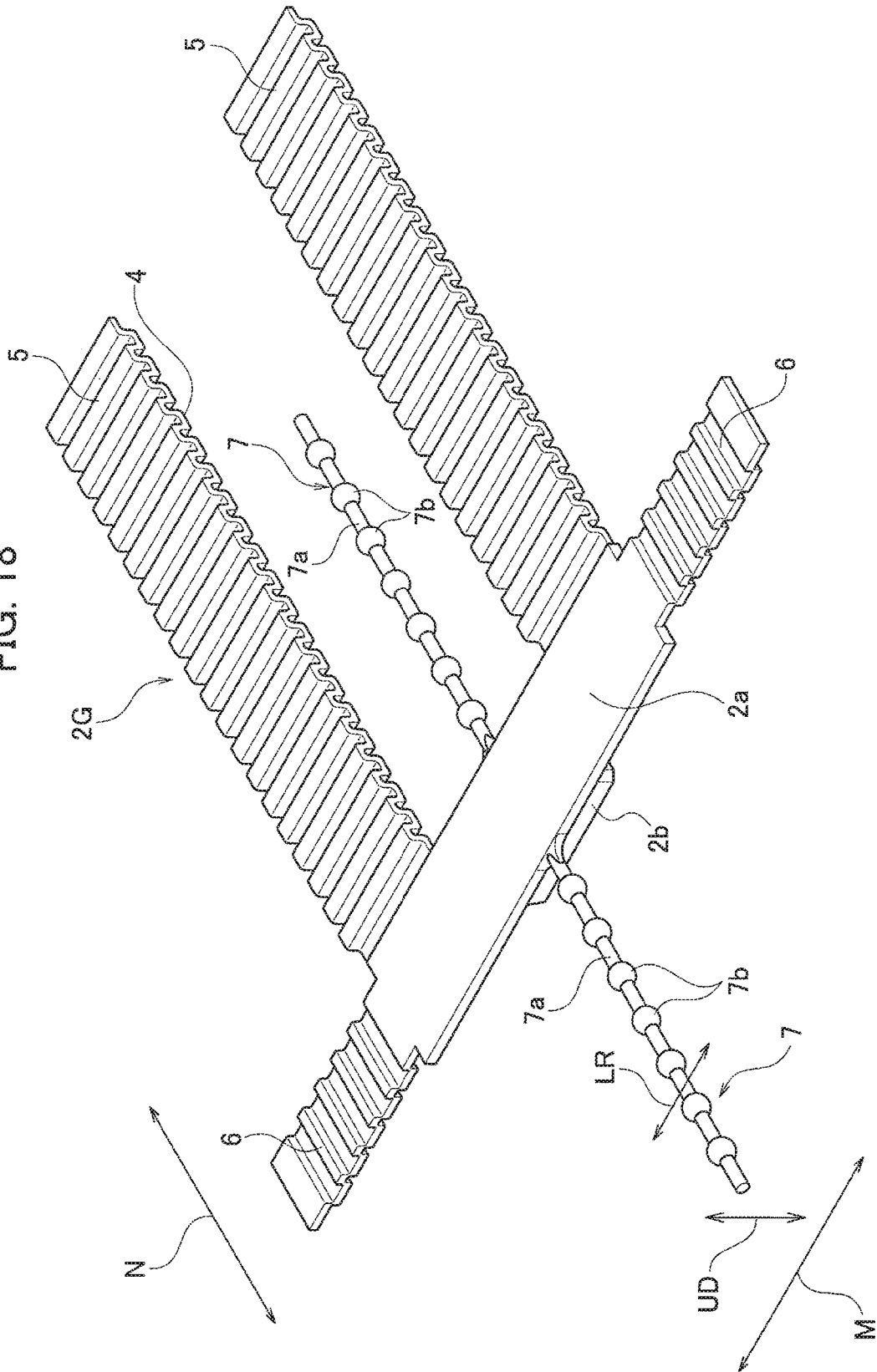


FIG. 19

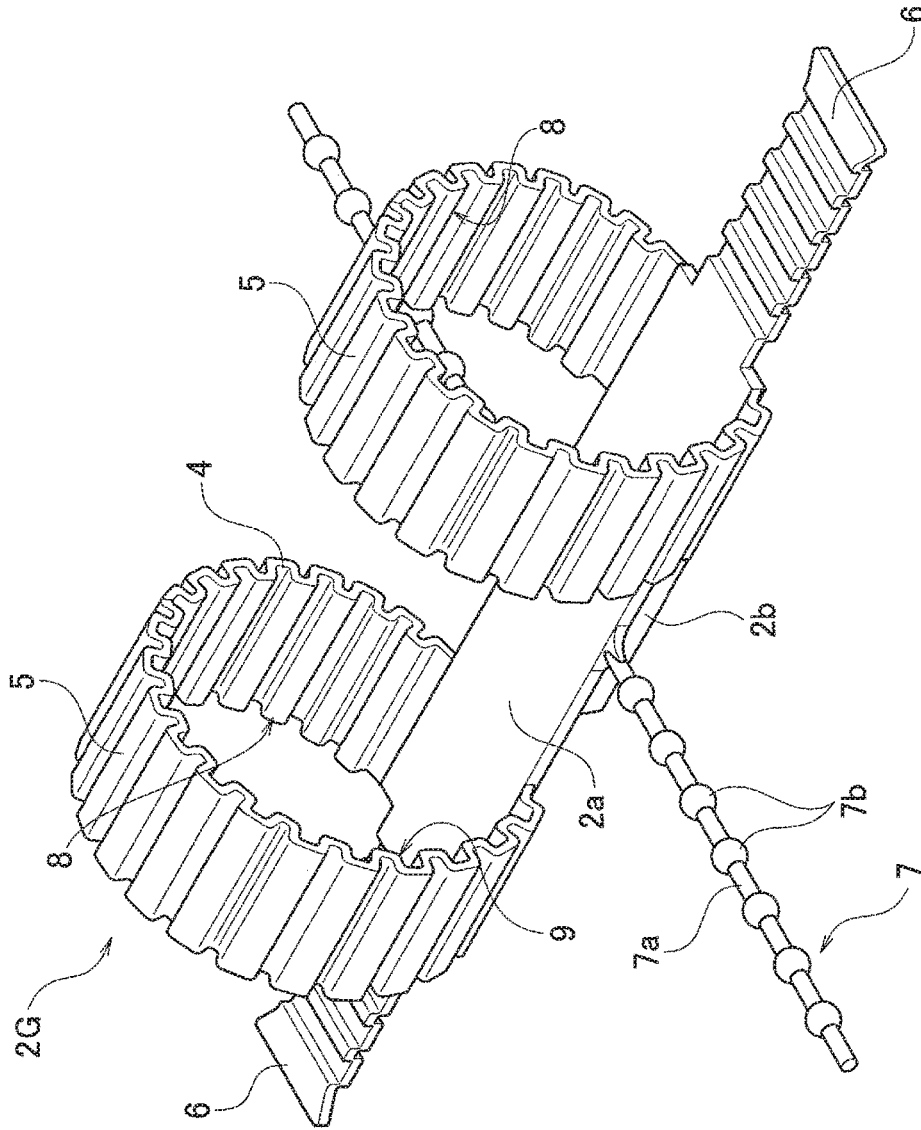


FIG. 20

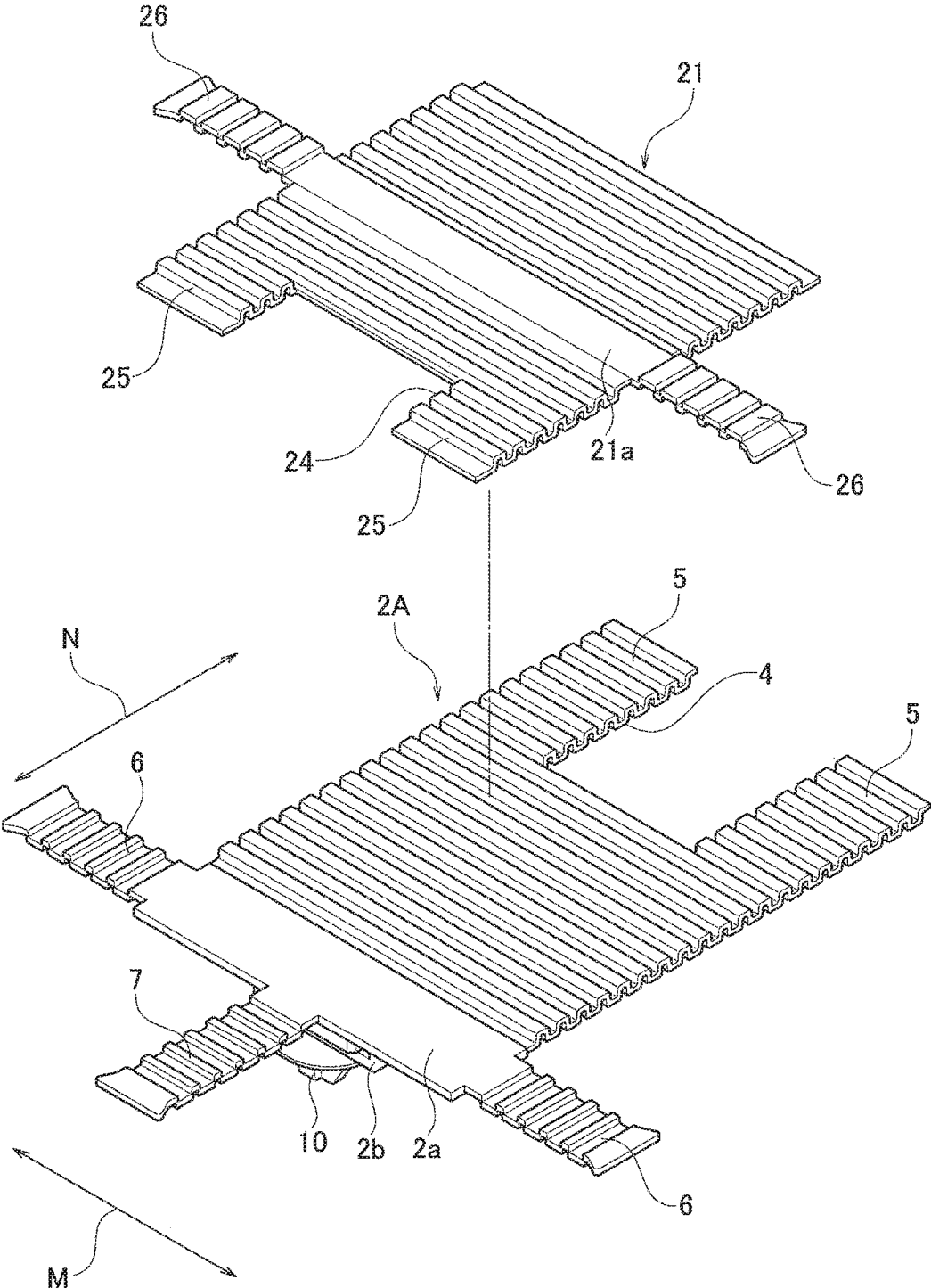


FIG. 21A

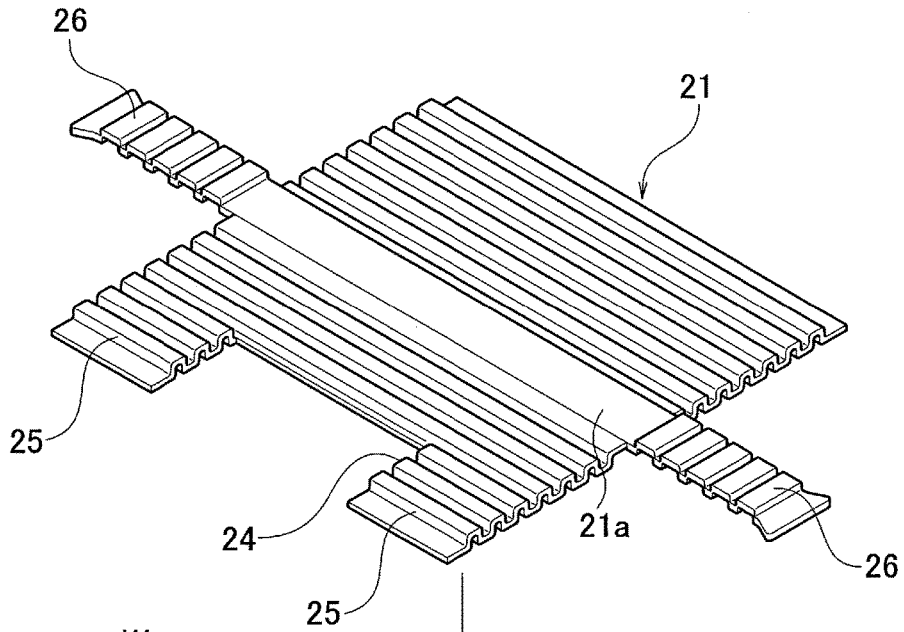


FIG. 21B

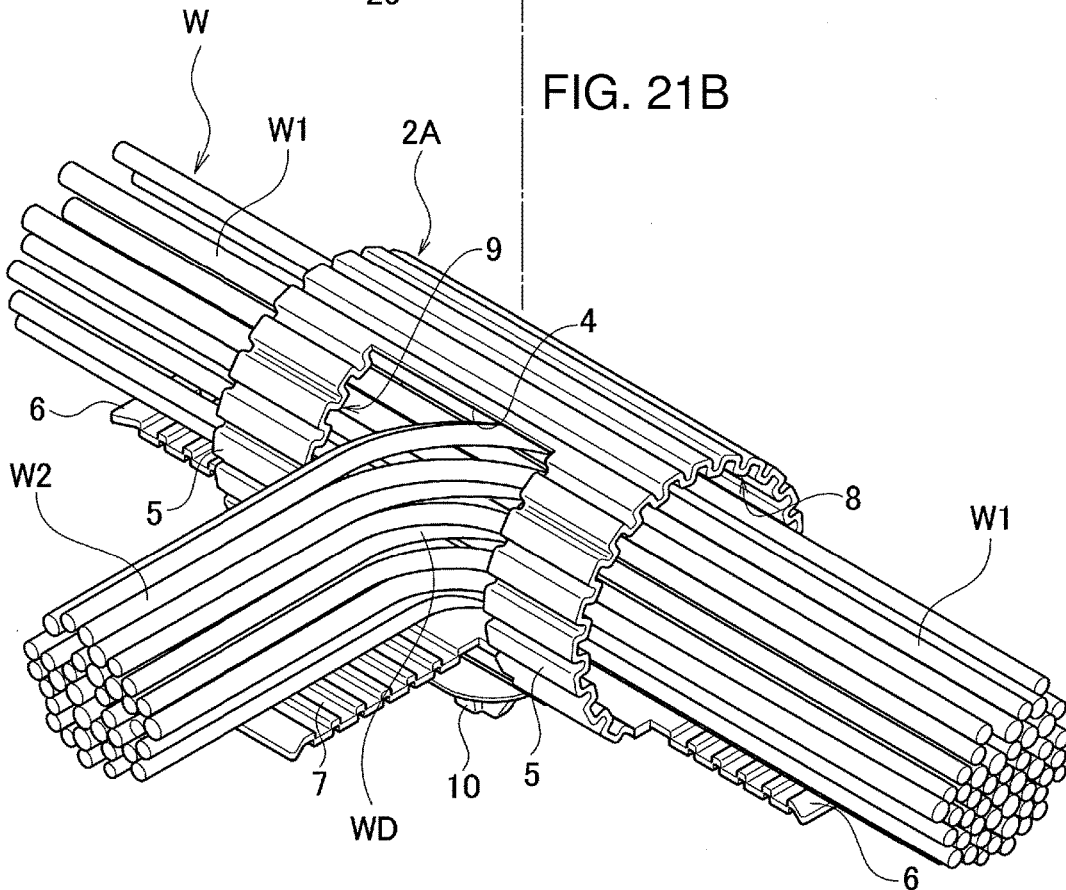


FIG. 22A

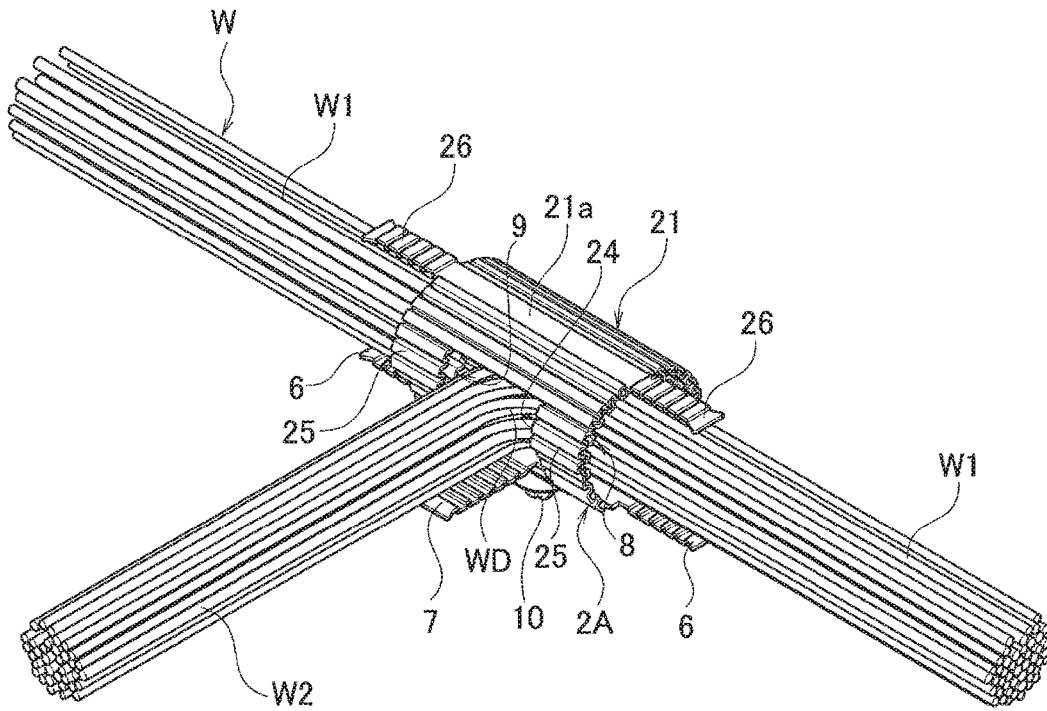


FIG. 22B

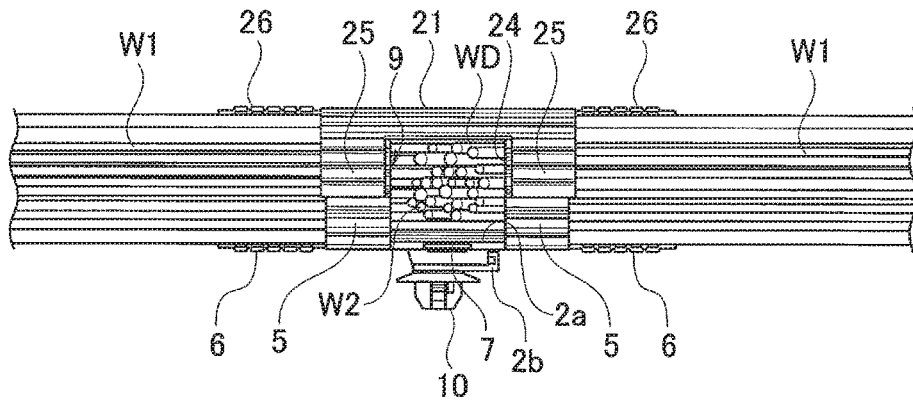


FIG. 23A

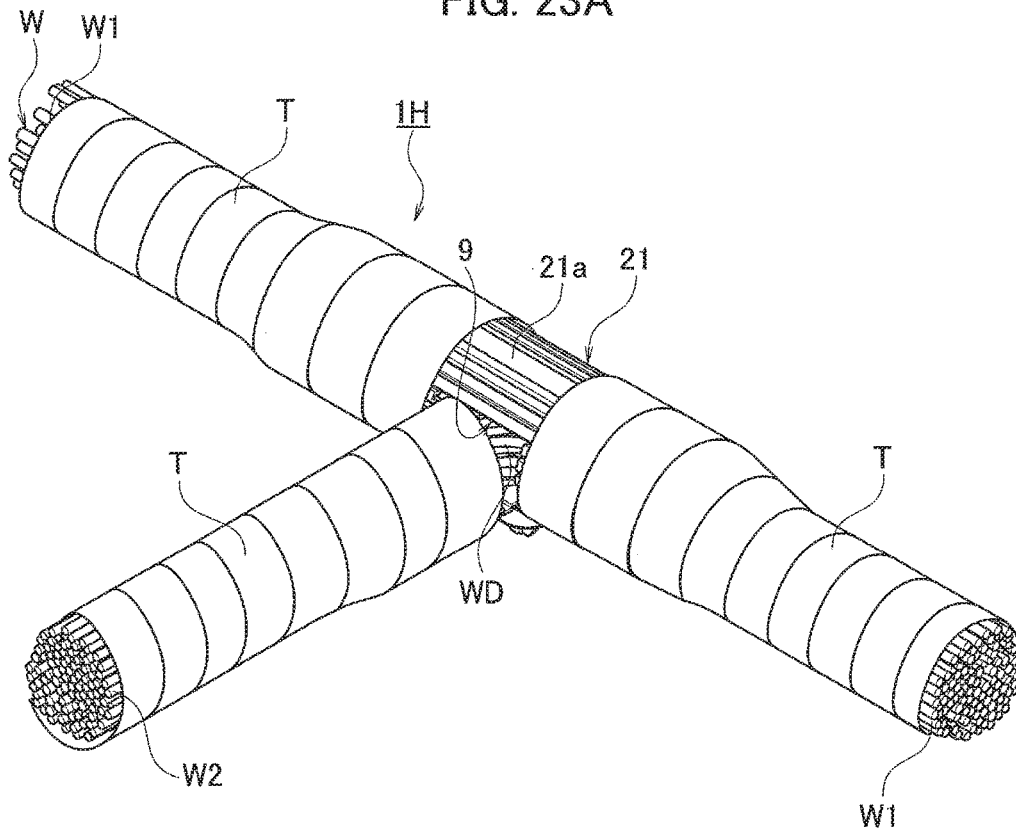


FIG. 23B

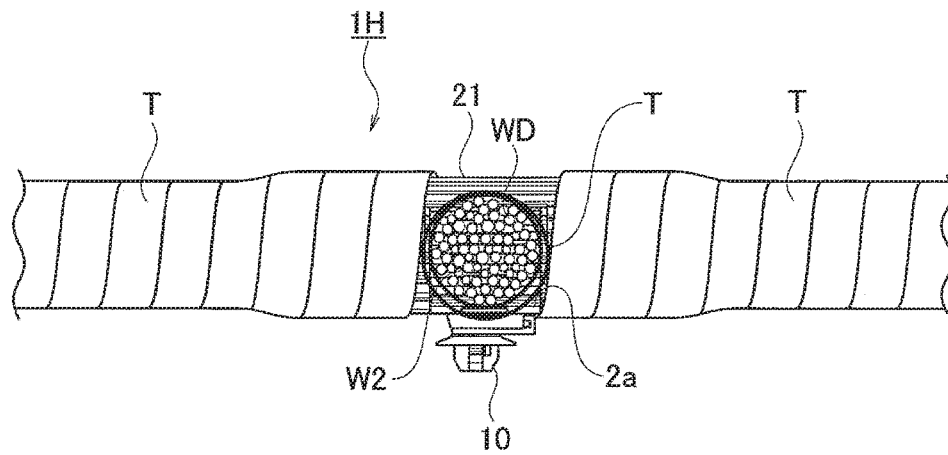


FIG. 24

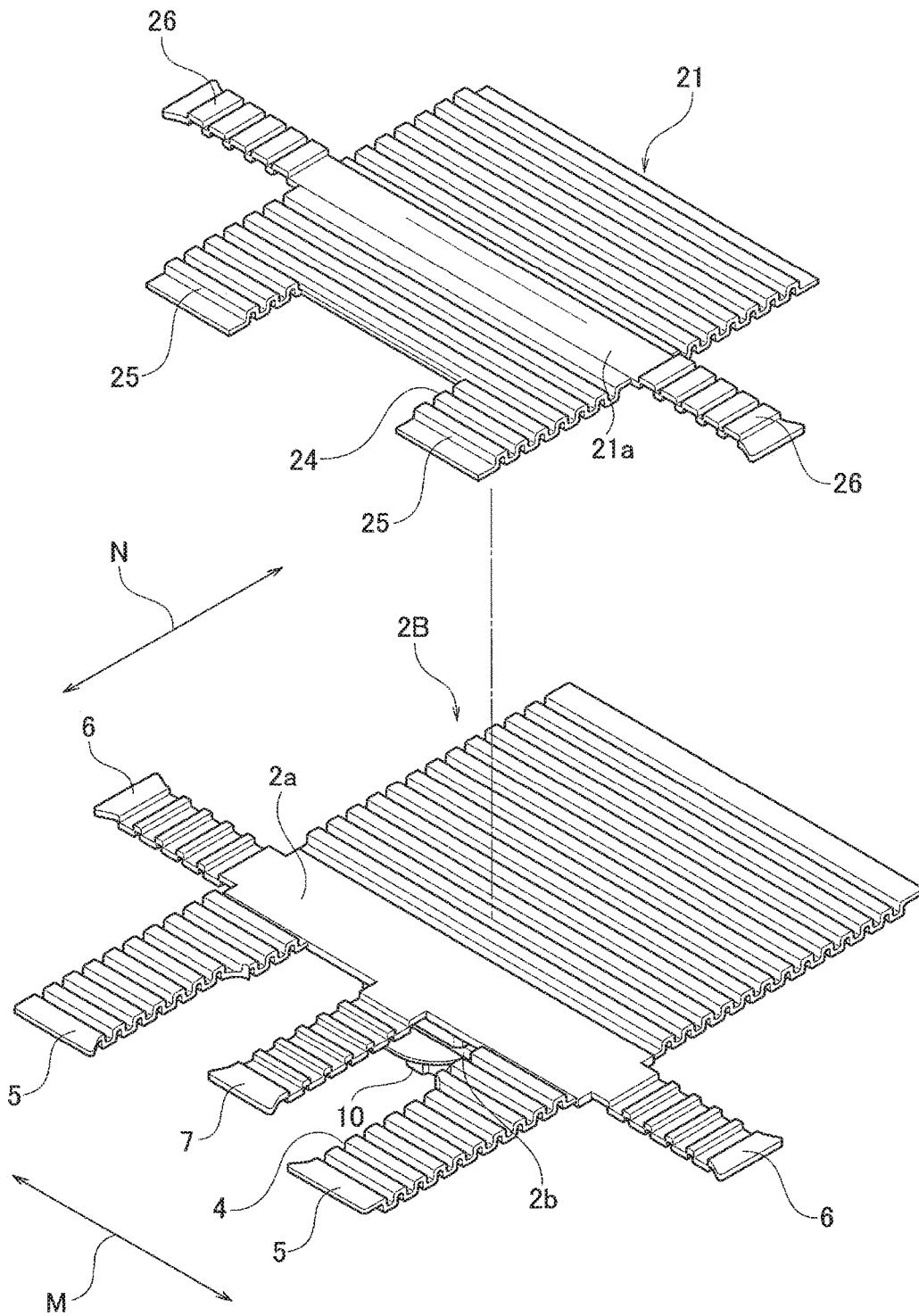


FIG. 25

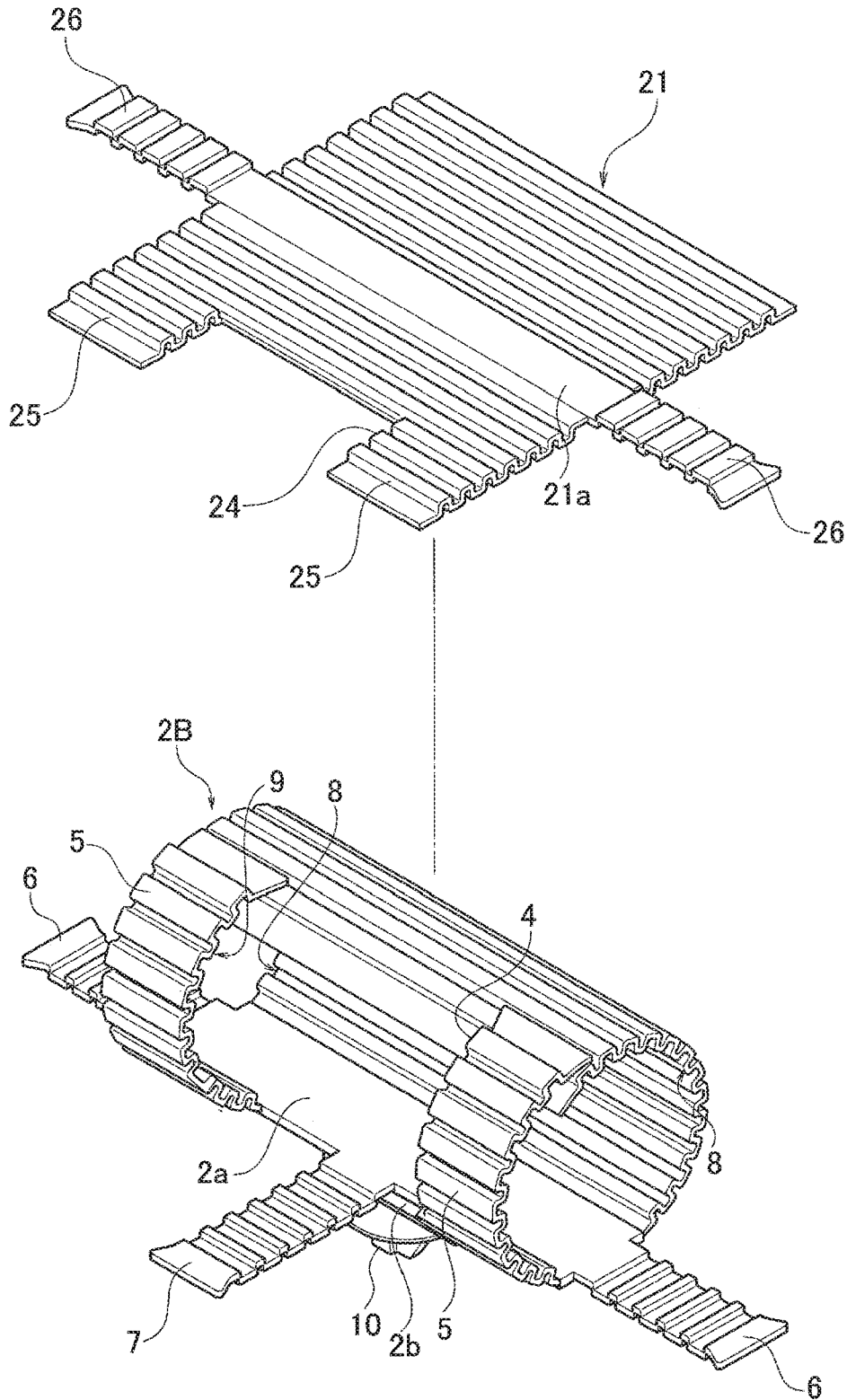


FIG. 26

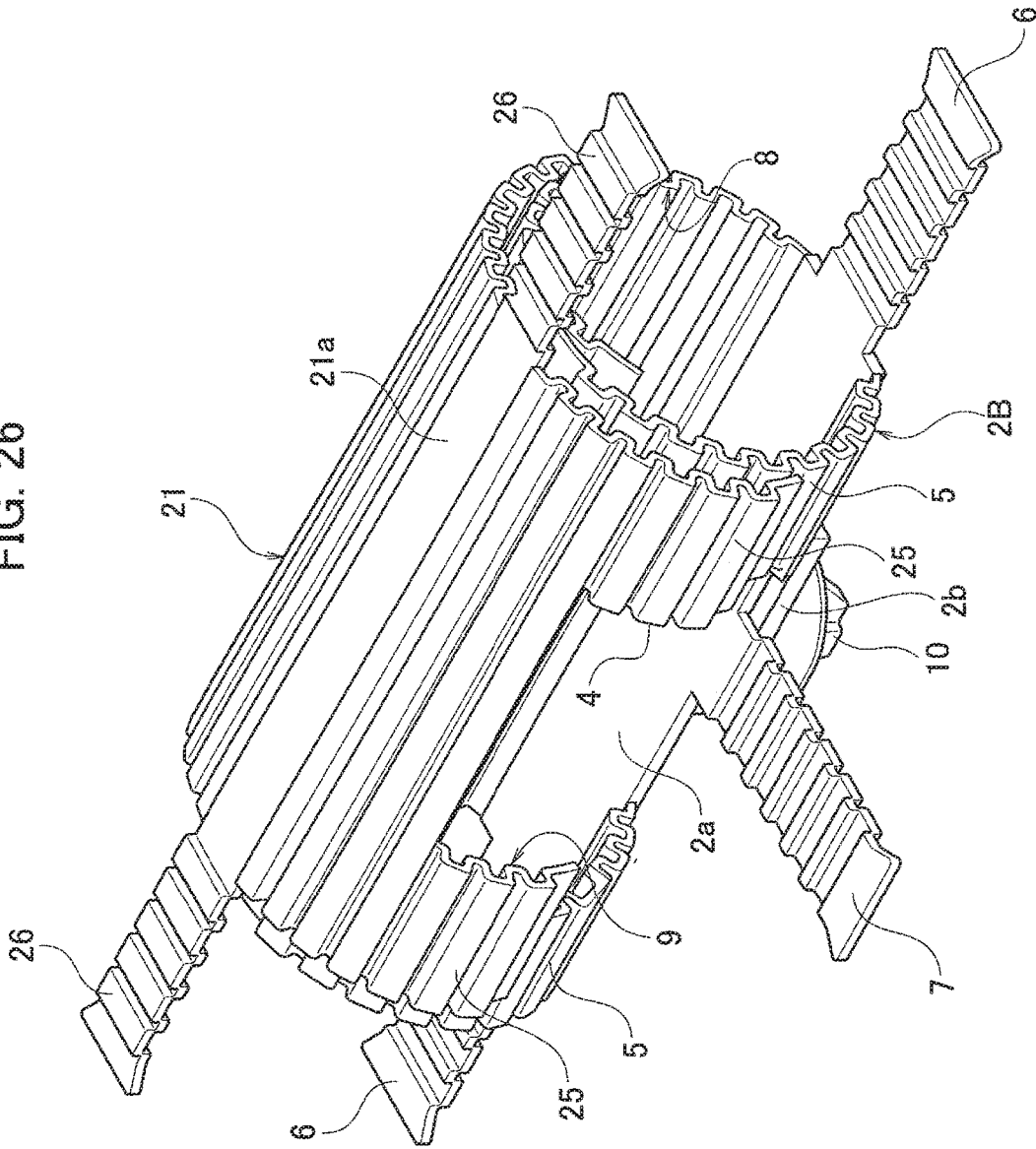


FIG. 27

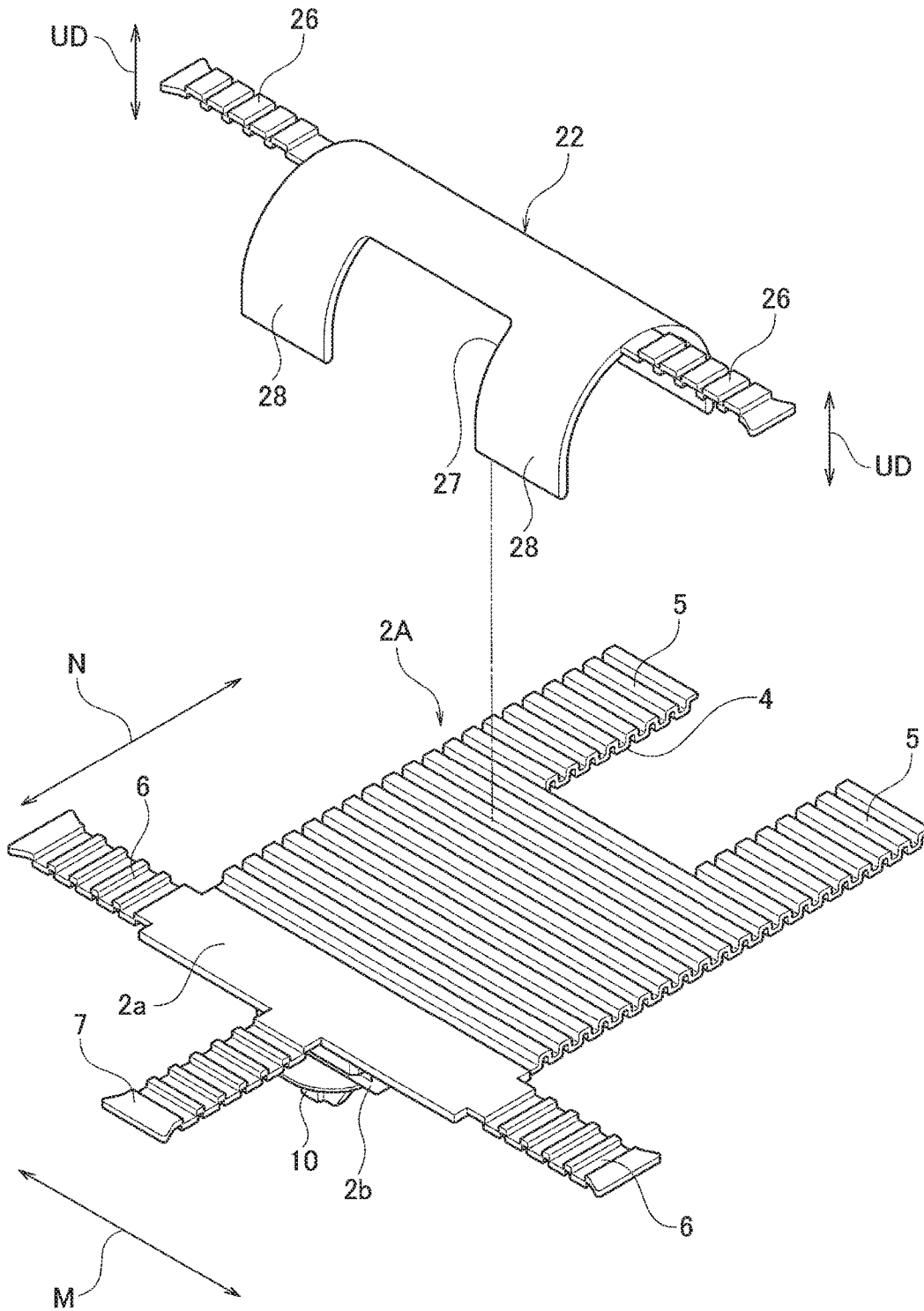


FIG. 28

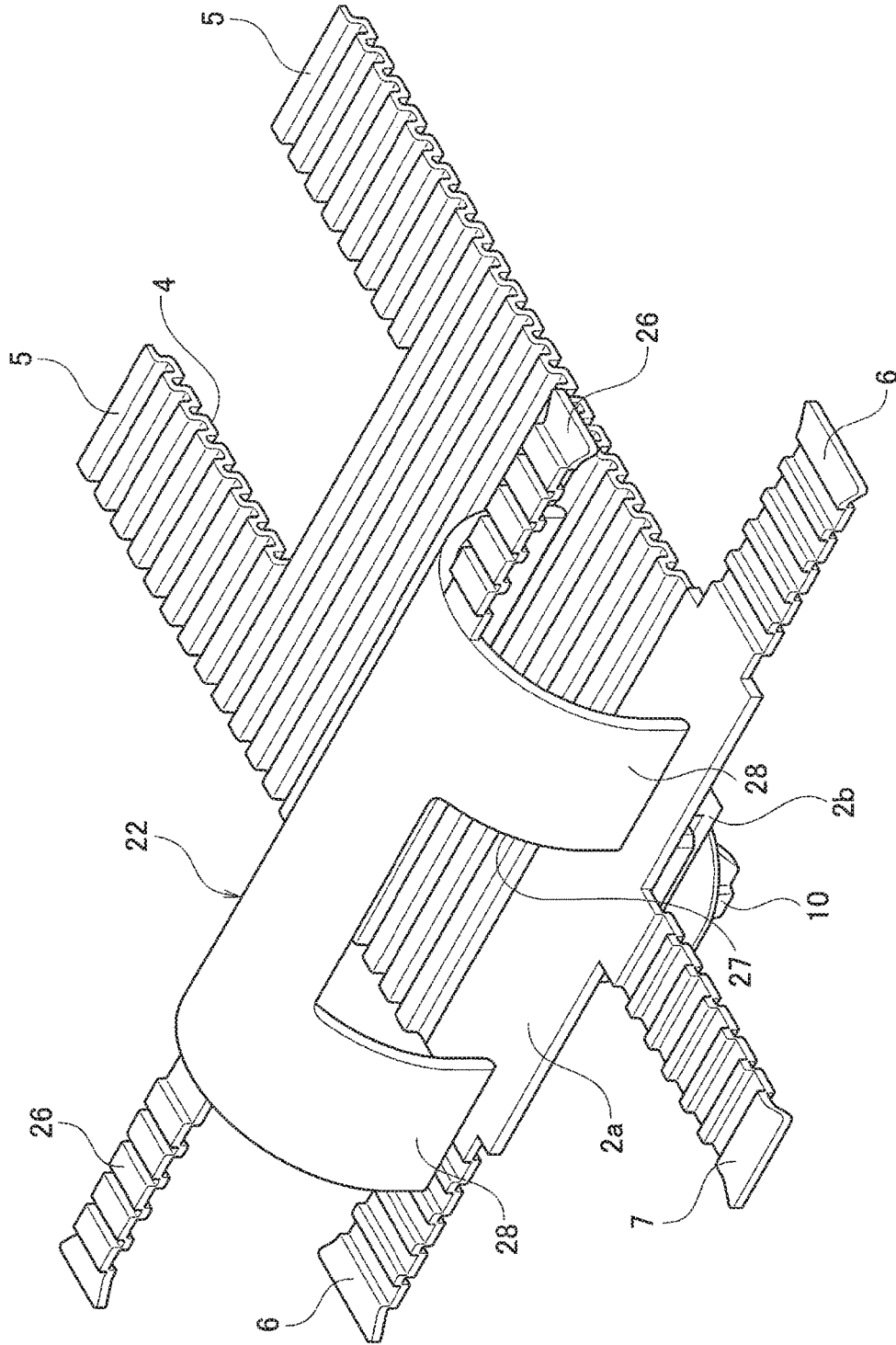


FIG. 29

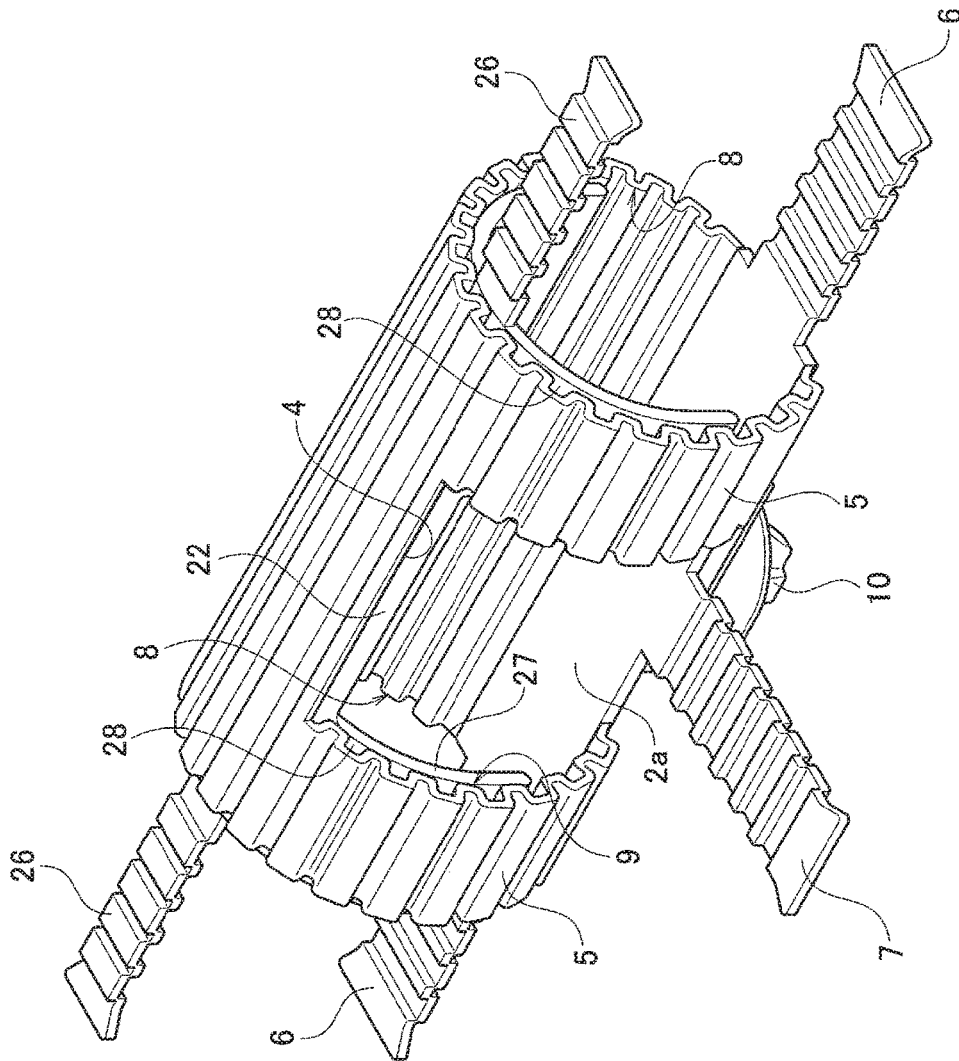


FIG. 30

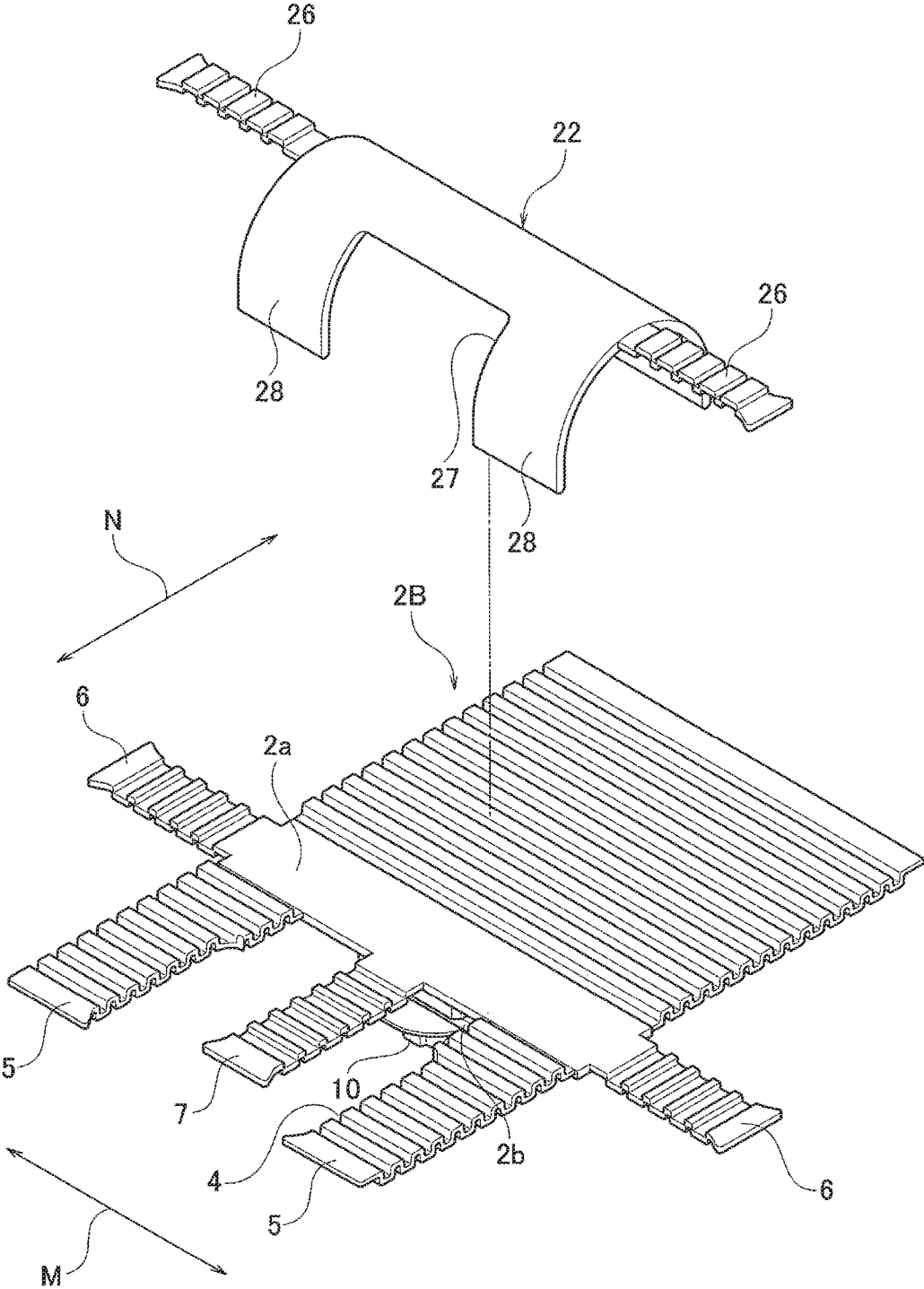


FIG. 31

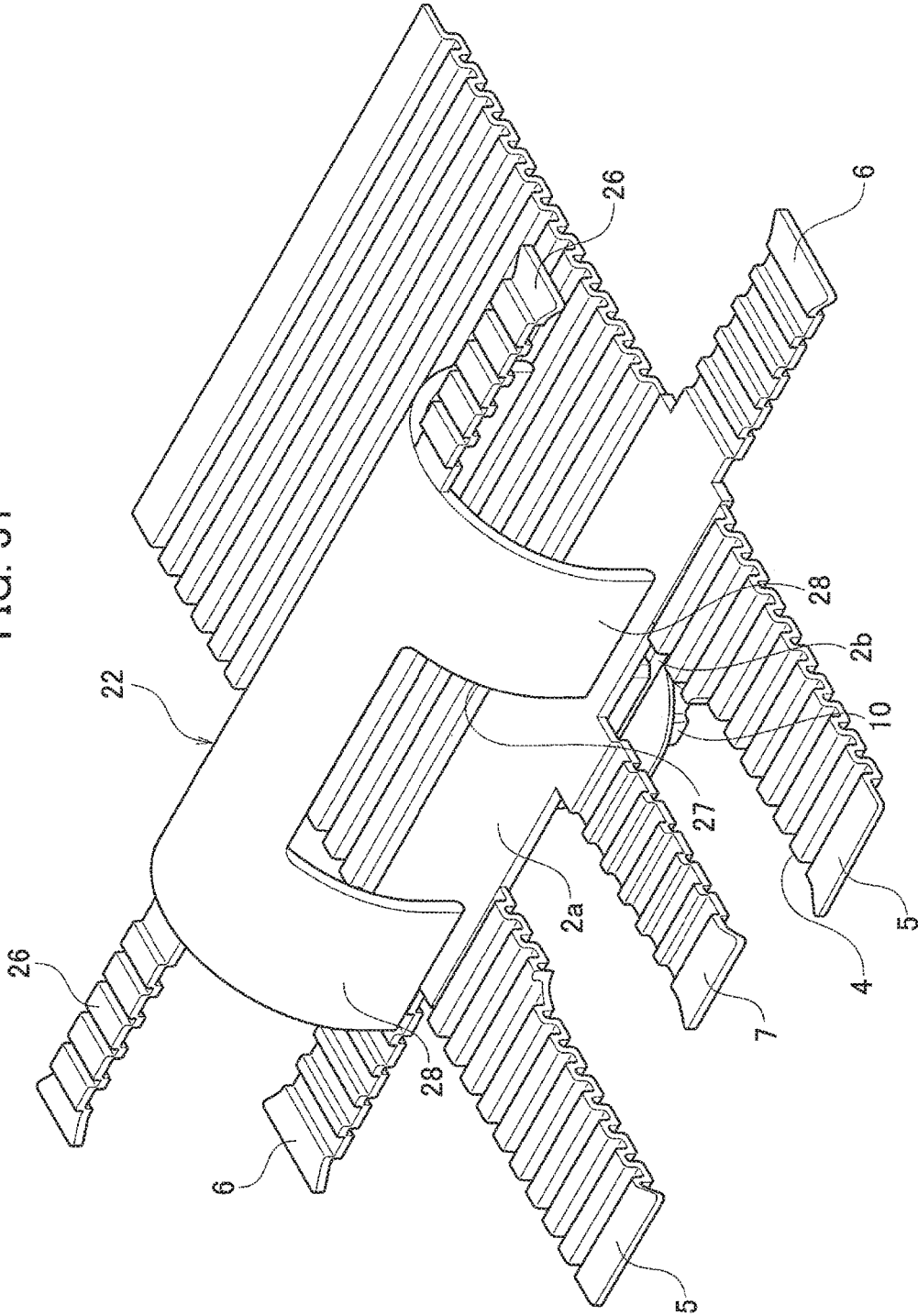


FIG. 32

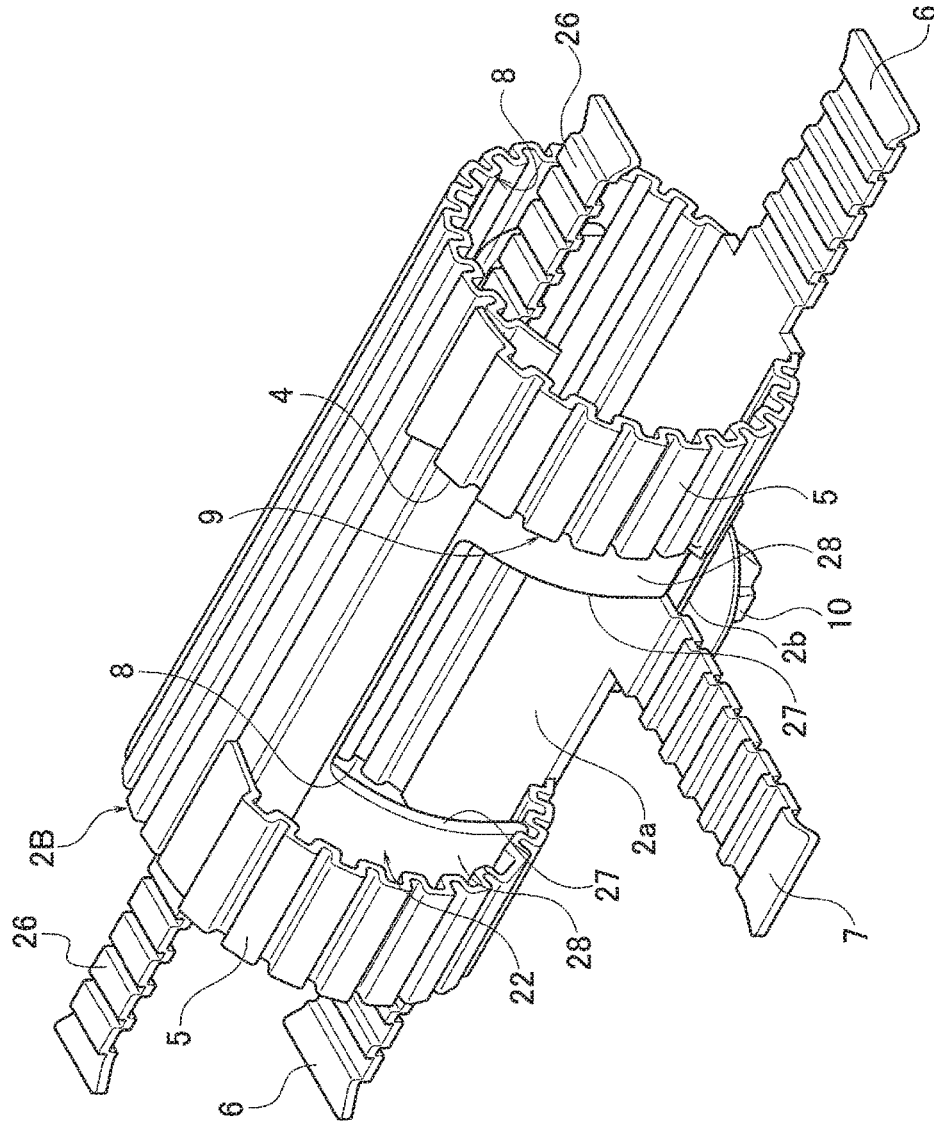


FIG. 33

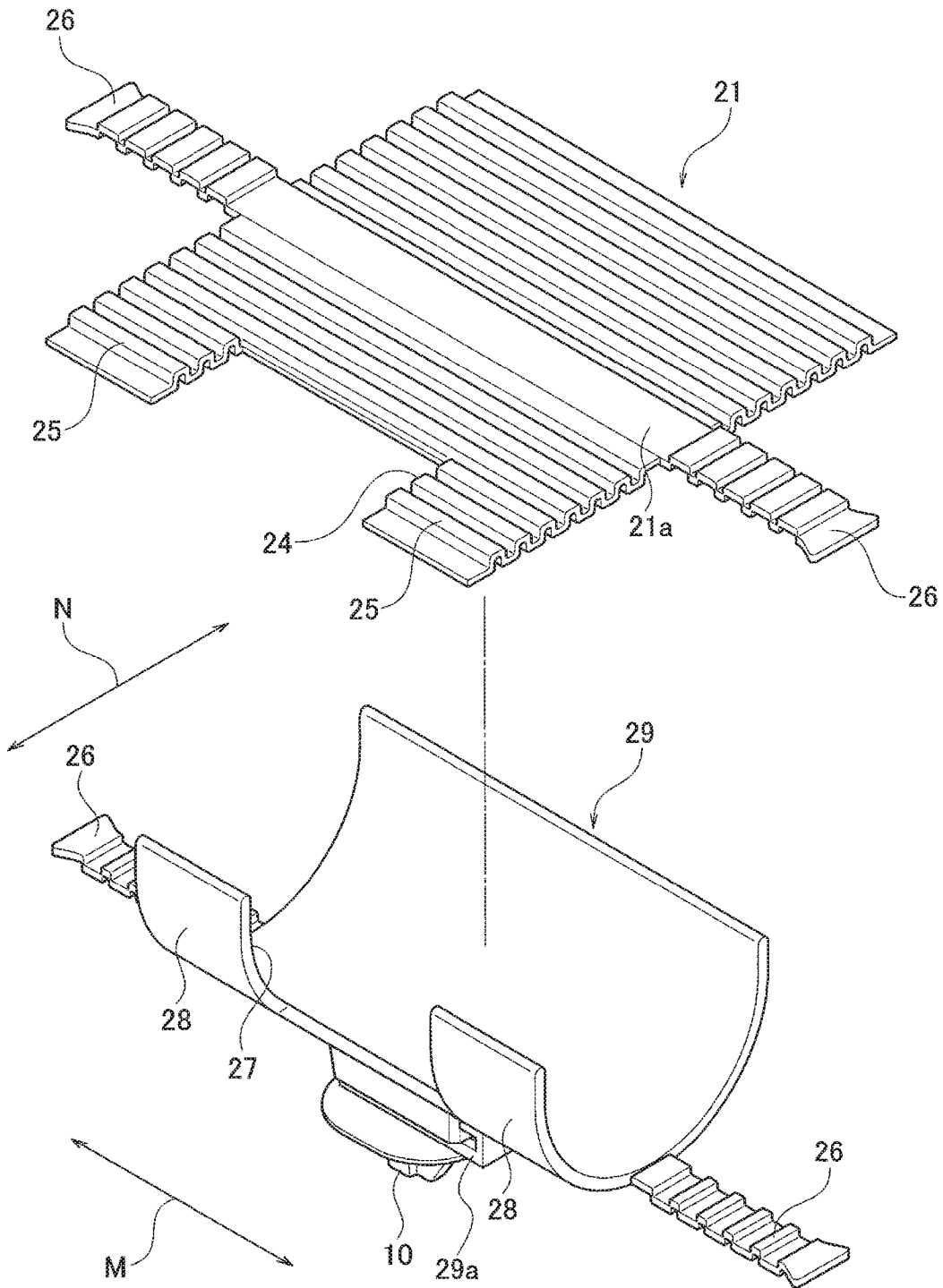


FIG. 34

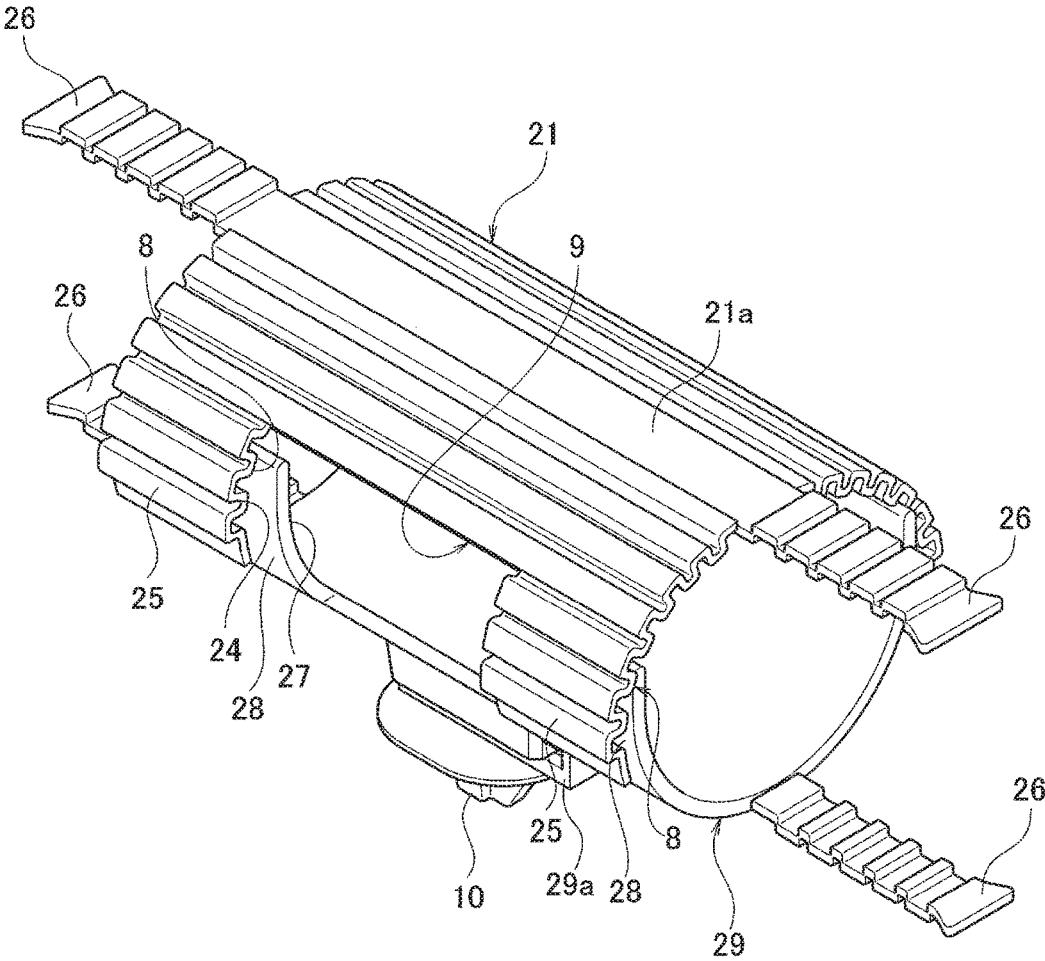


FIG. 35

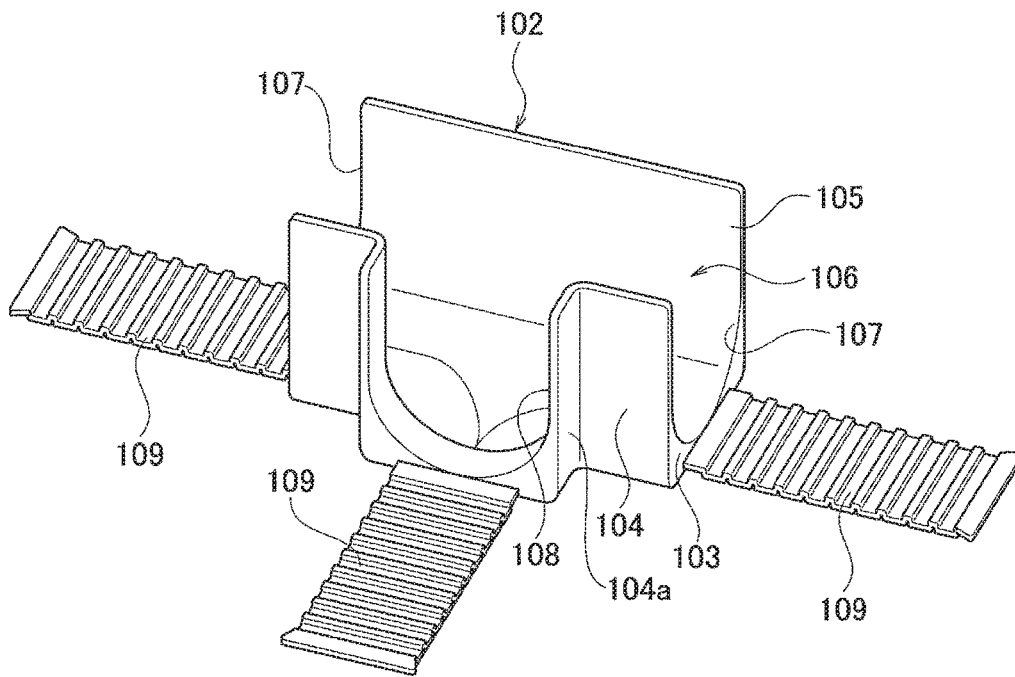
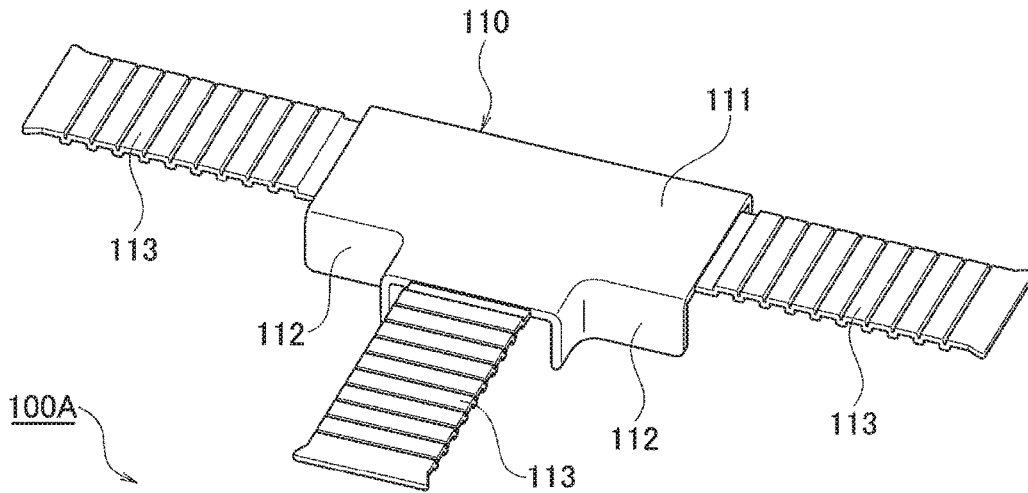
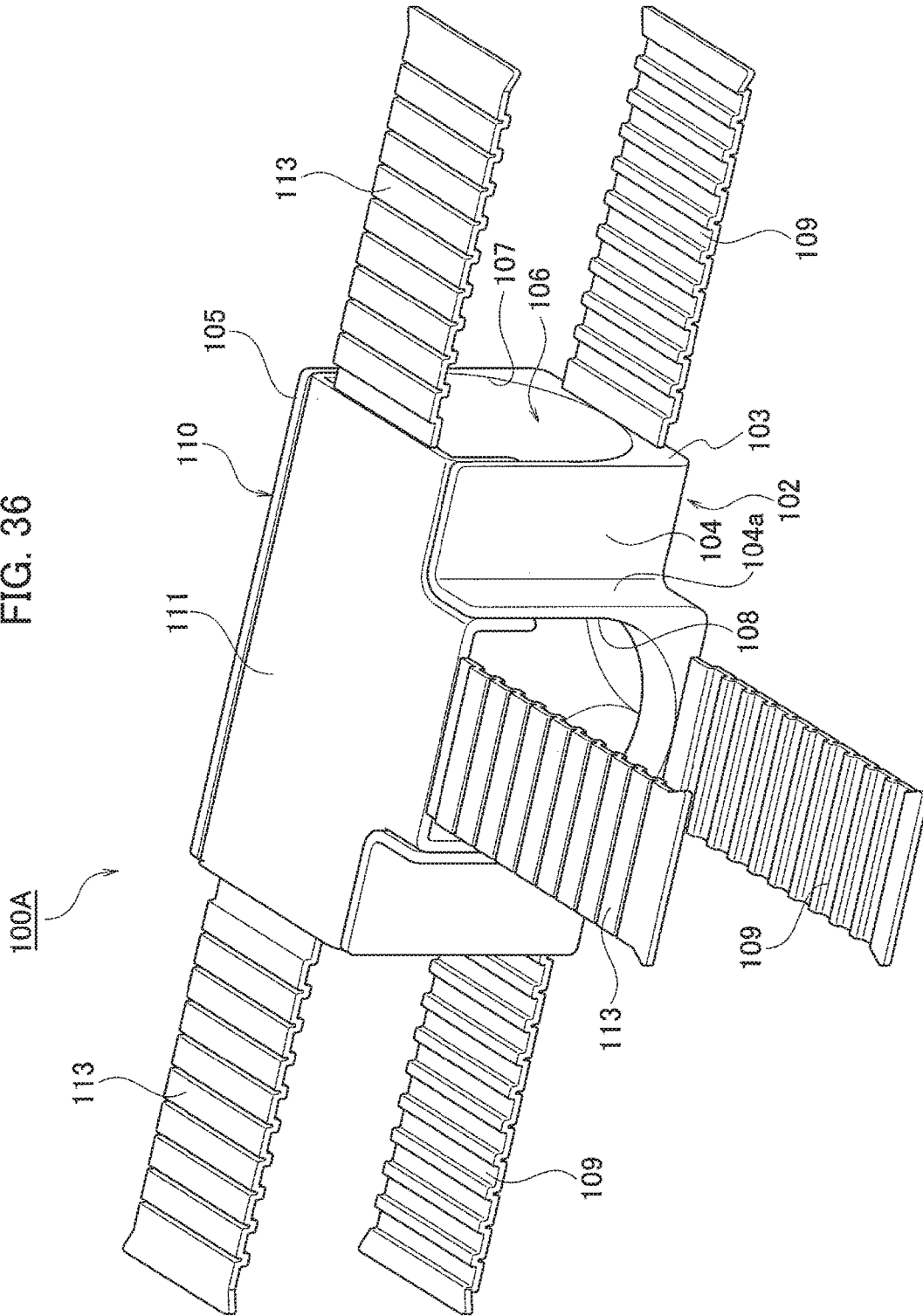


FIG. 36



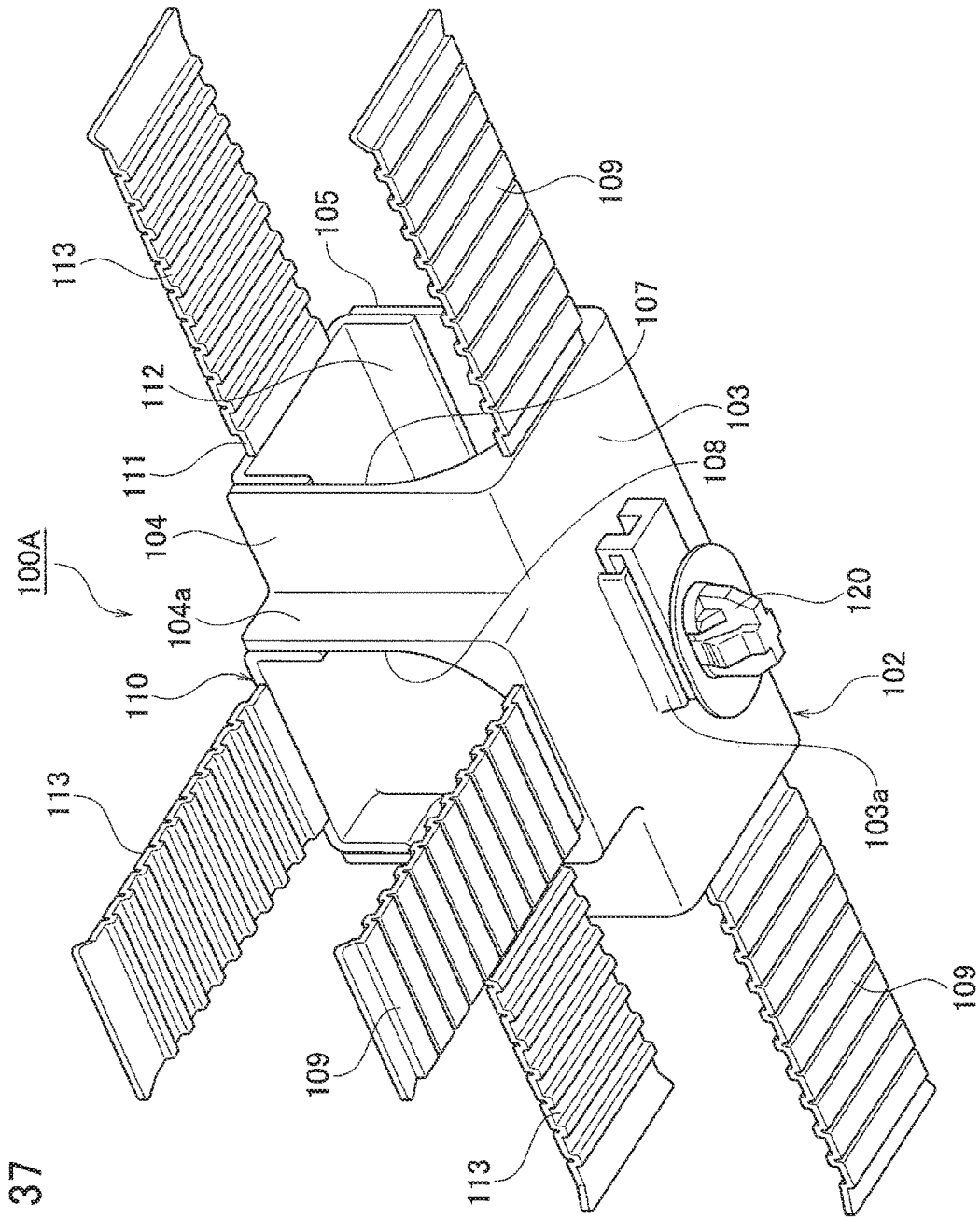


FIG. 37

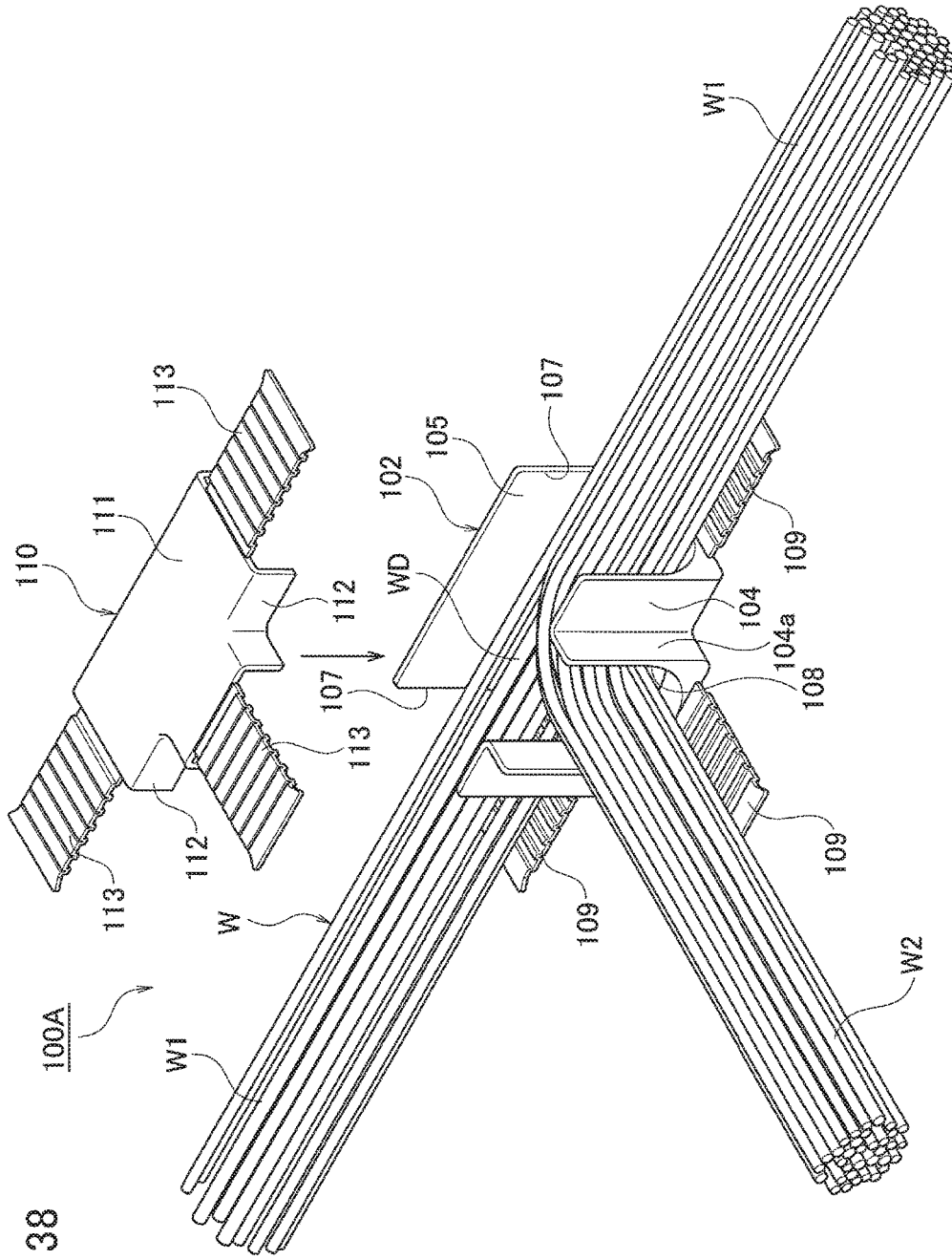


FIG. 38

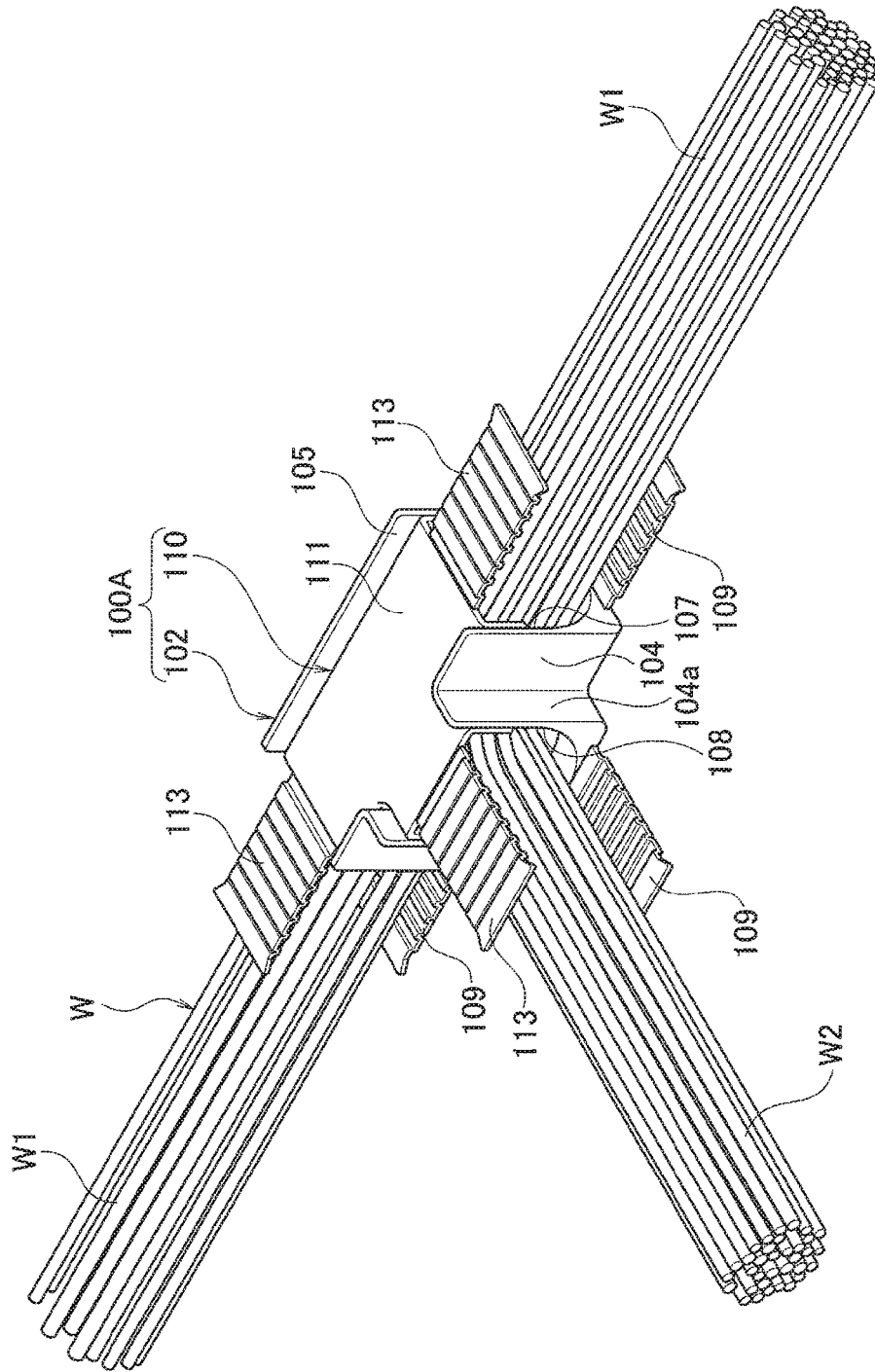


FIG. 39

FIG. 40

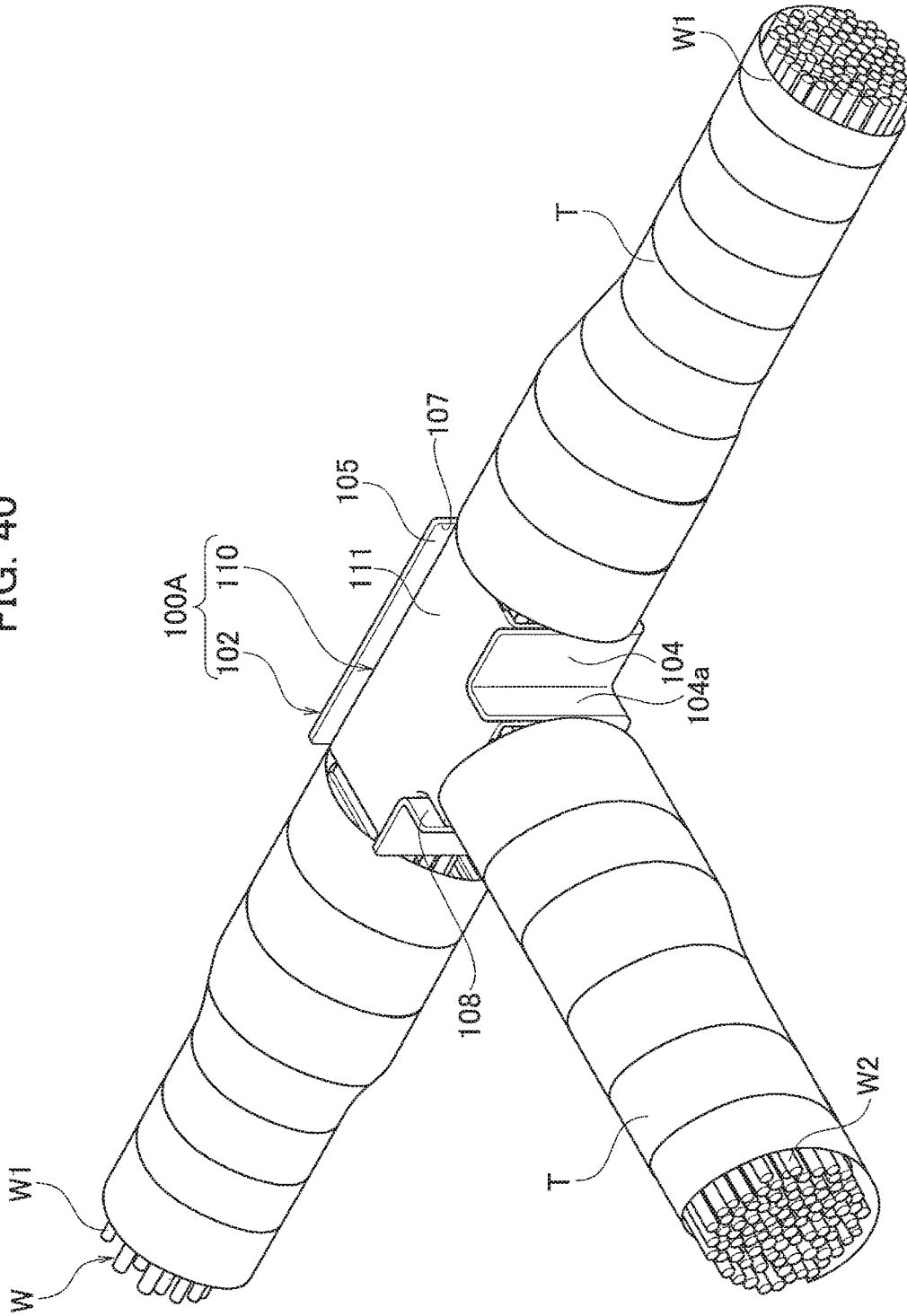


FIG. 41

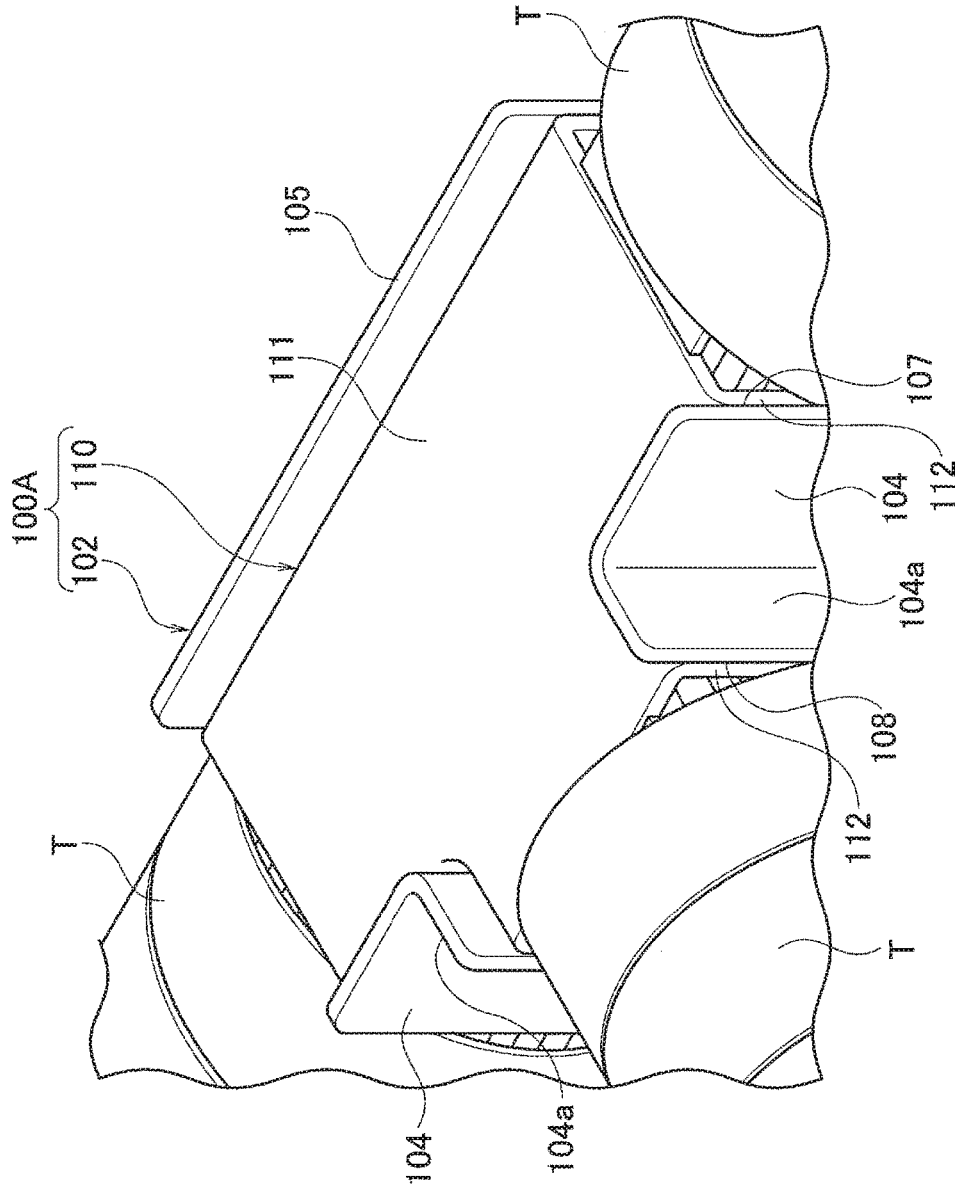


FIG. 42

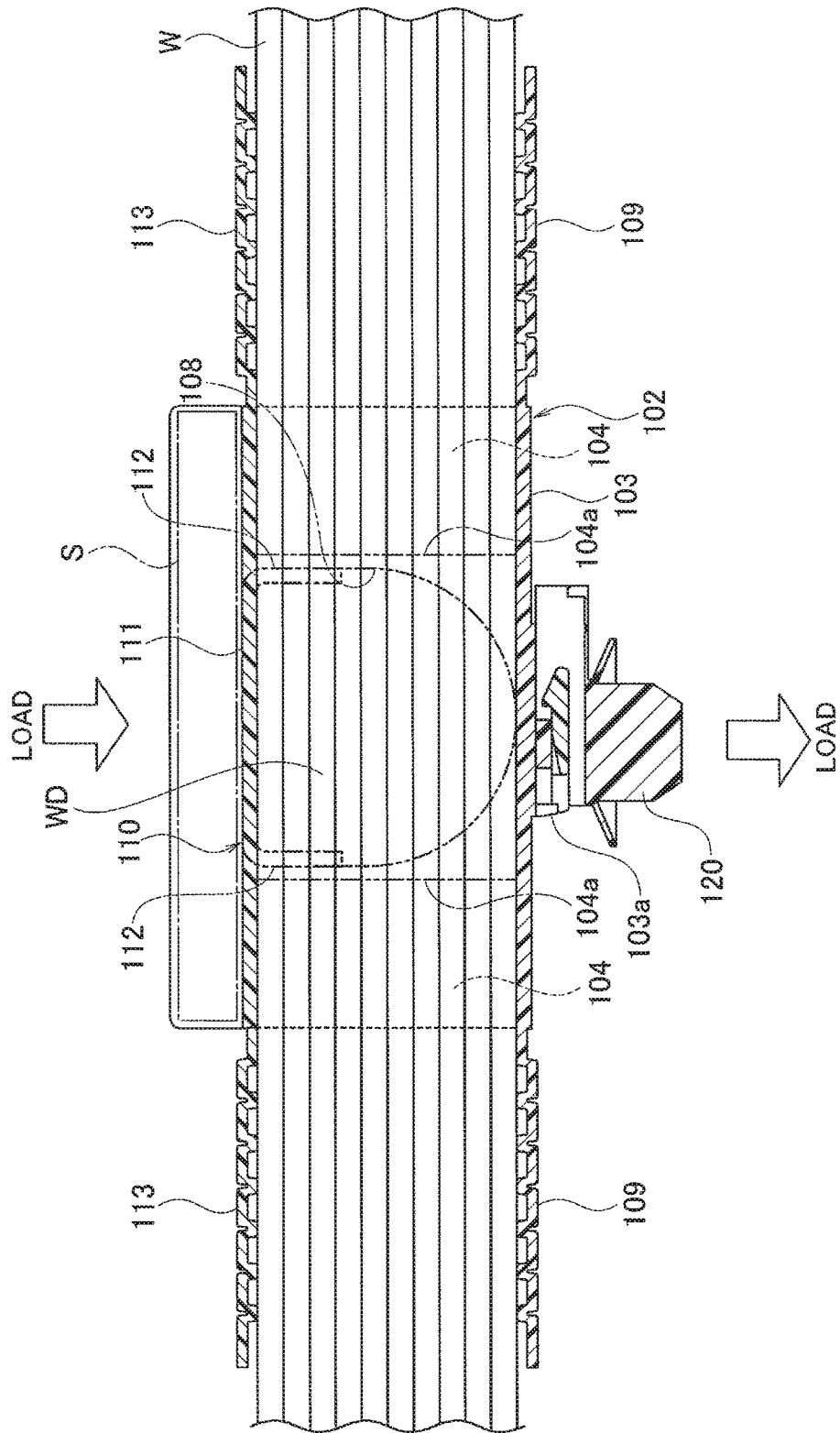


FIG. 43

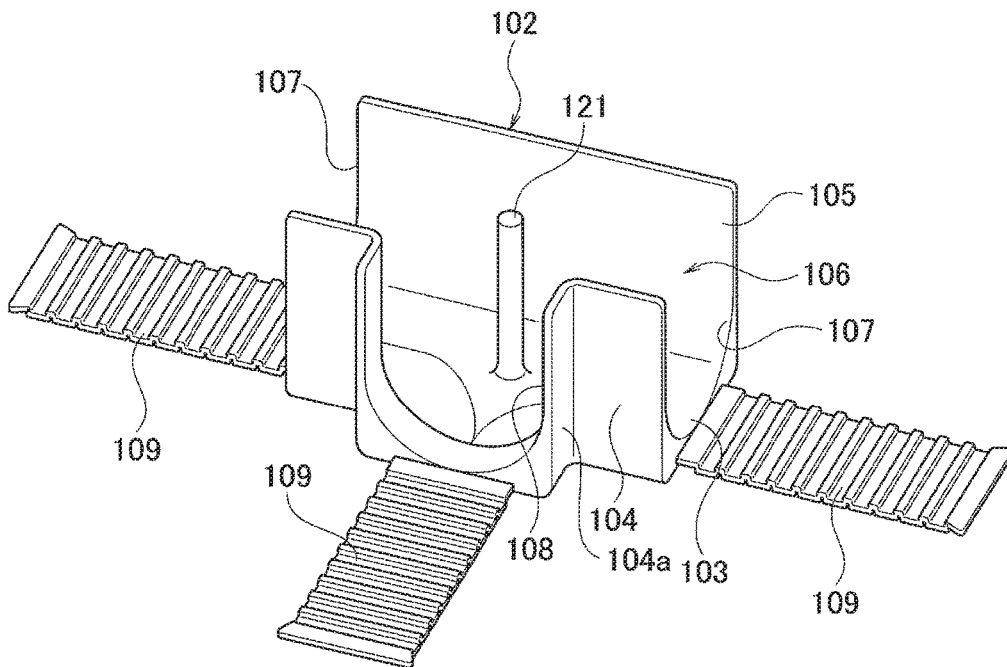
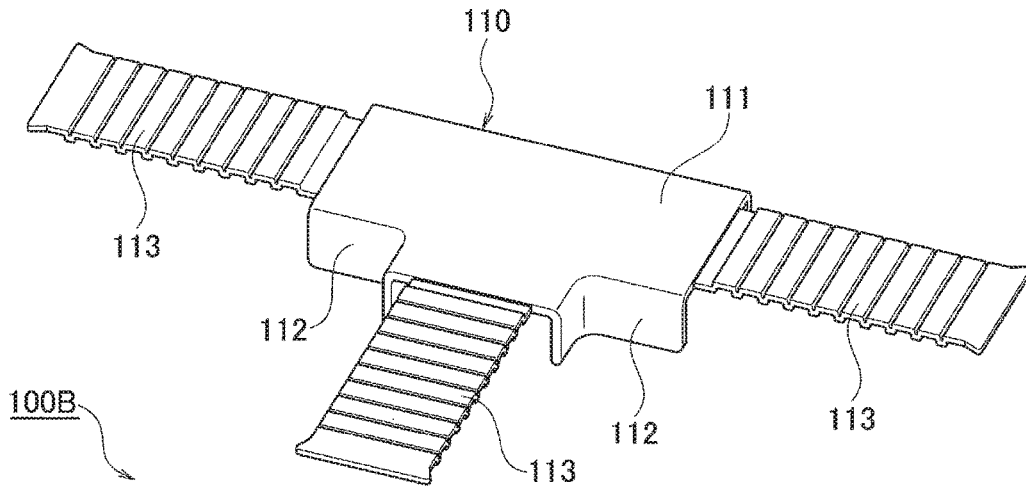


FIG. 44

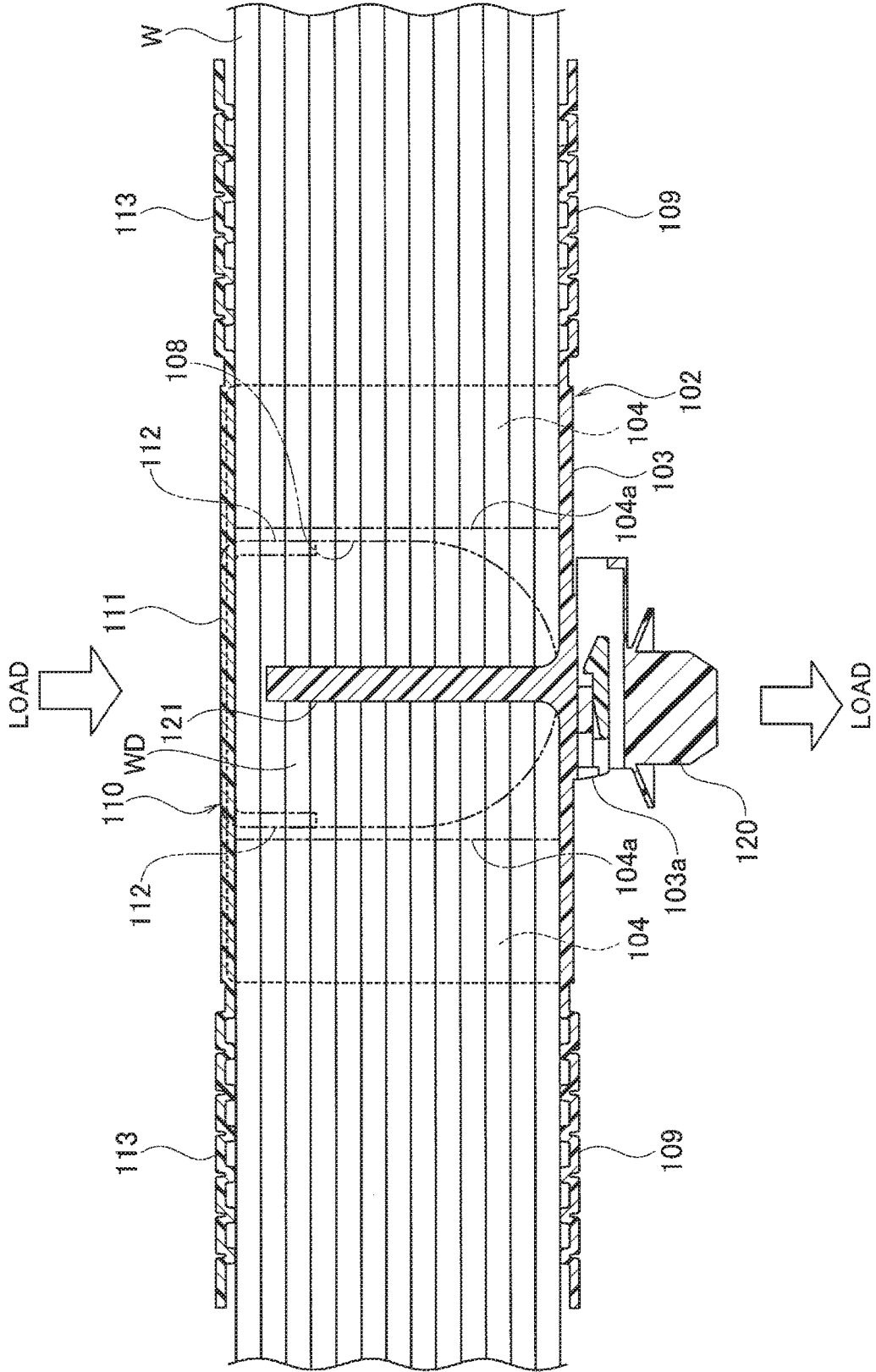


FIG. 45

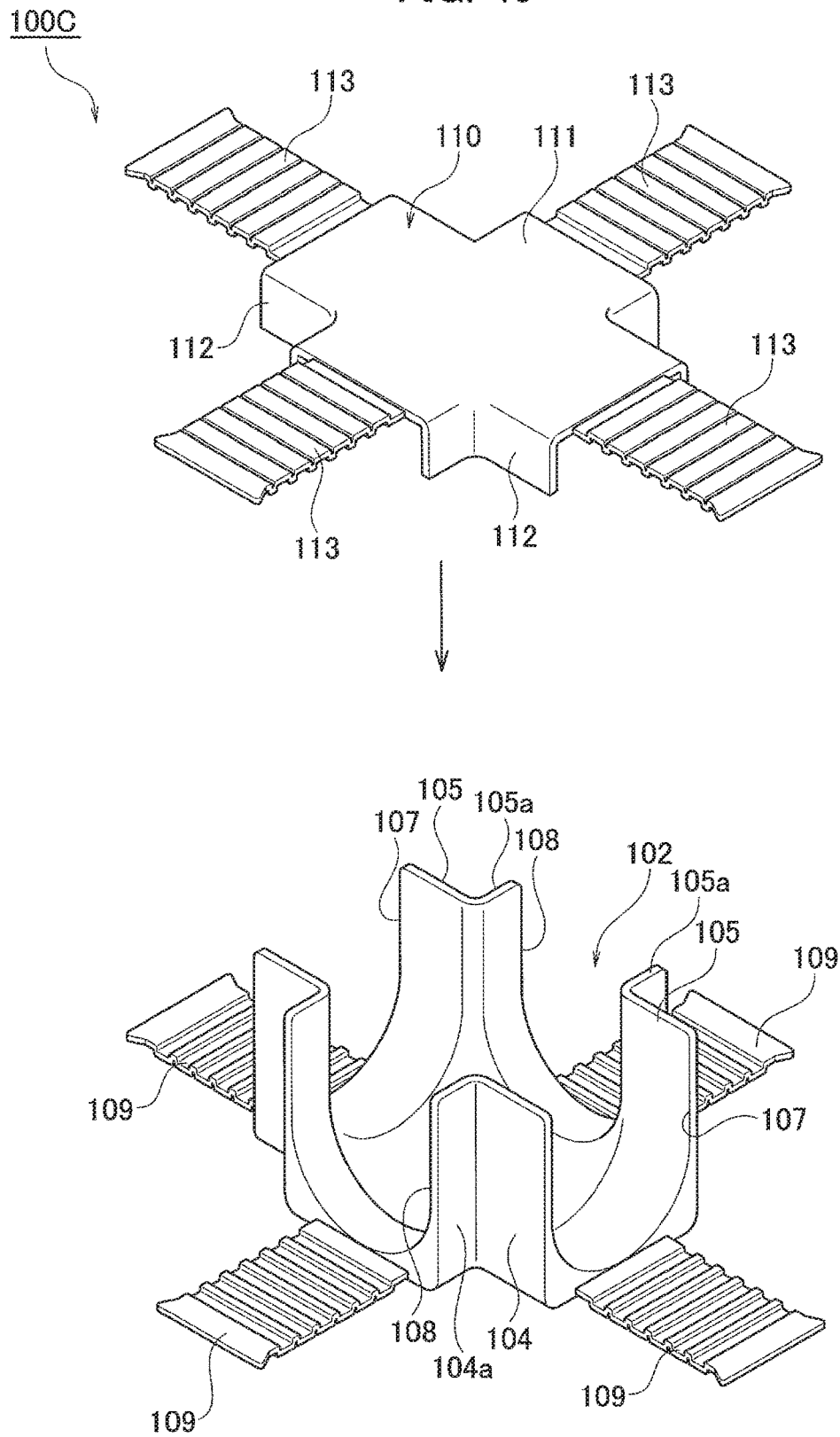


FIG. 46

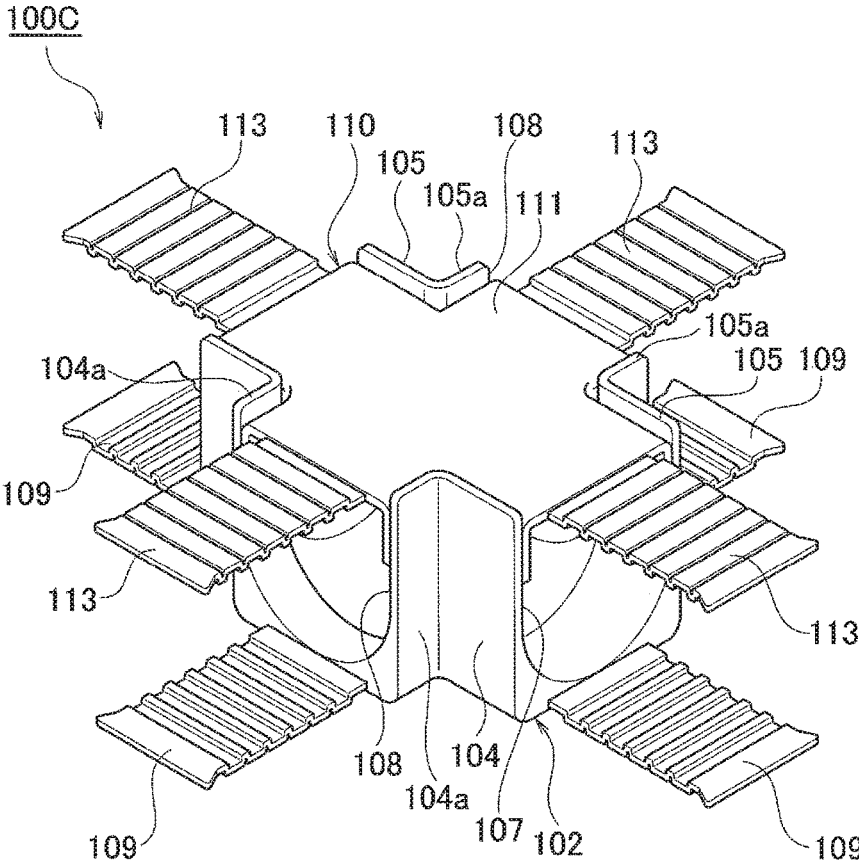


FIG. 47

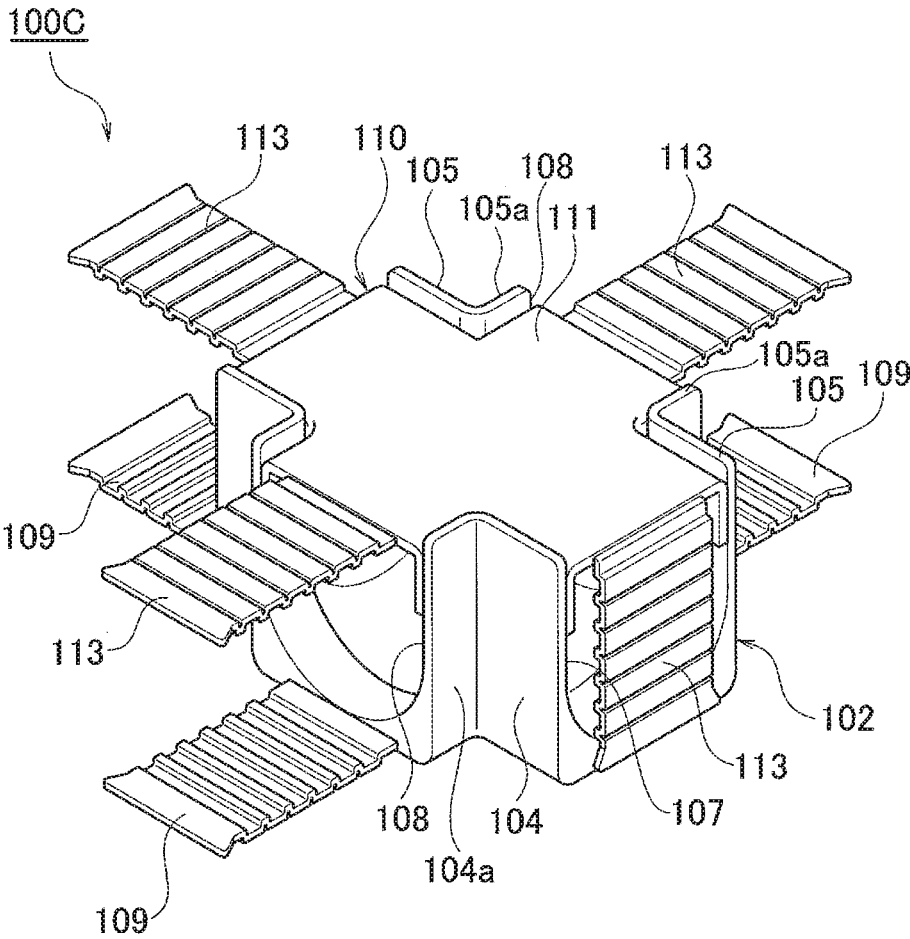


FIG. 48

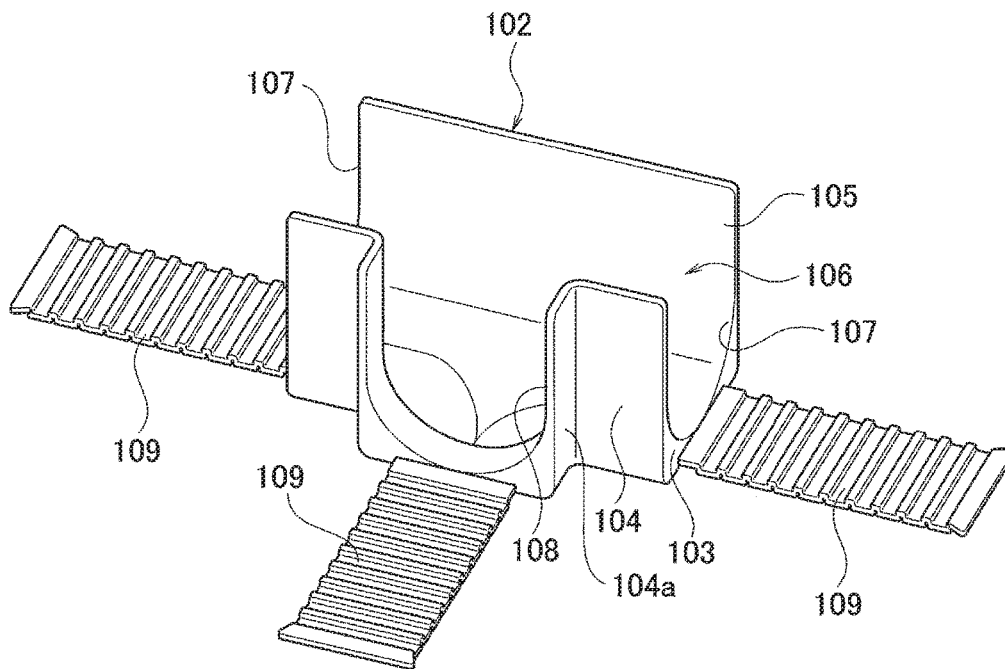
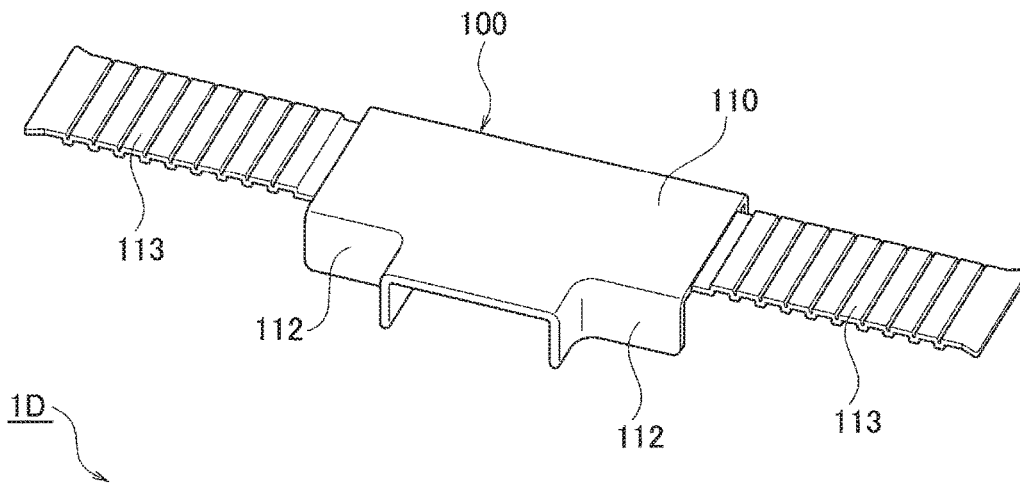


FIG. 49

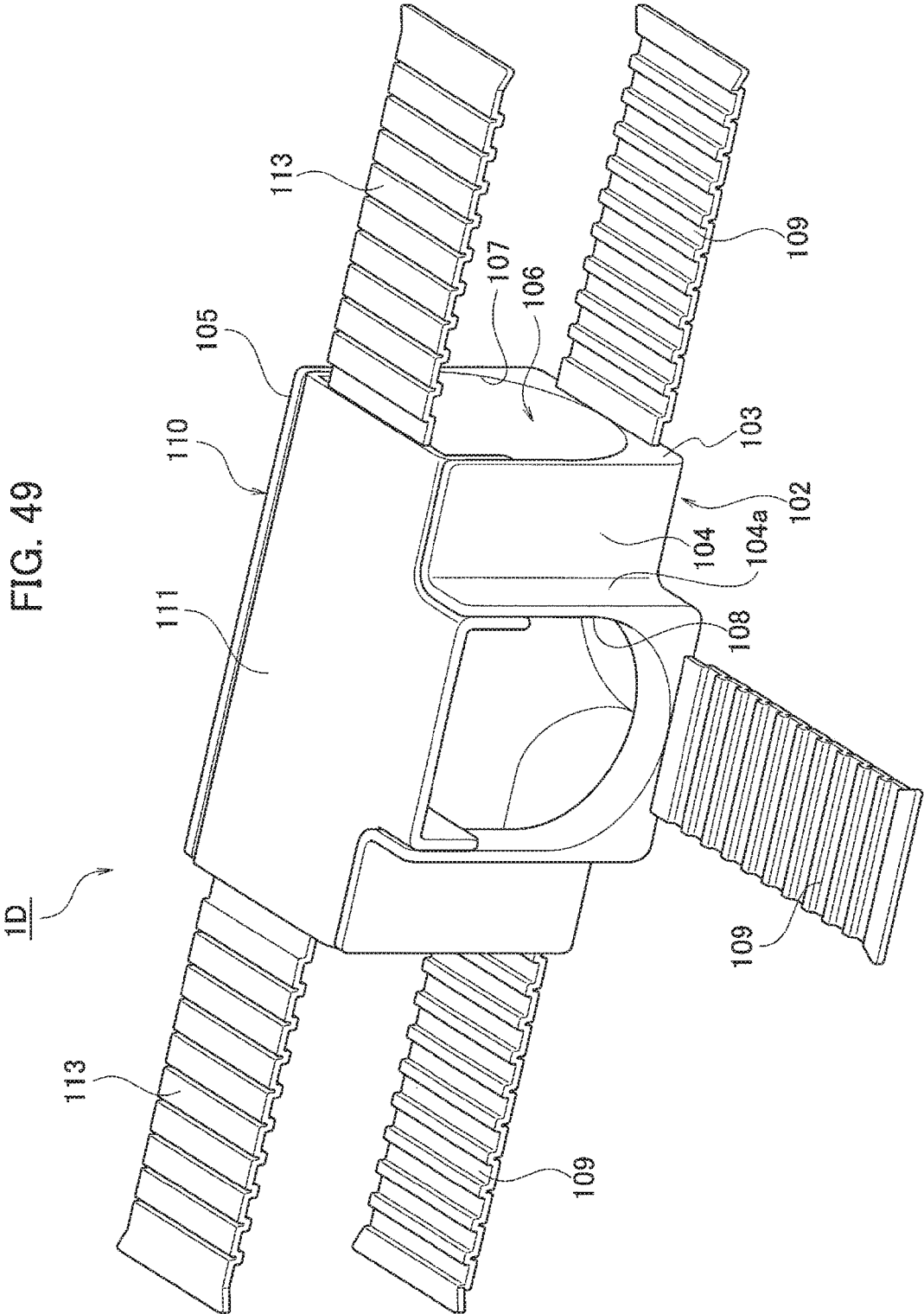
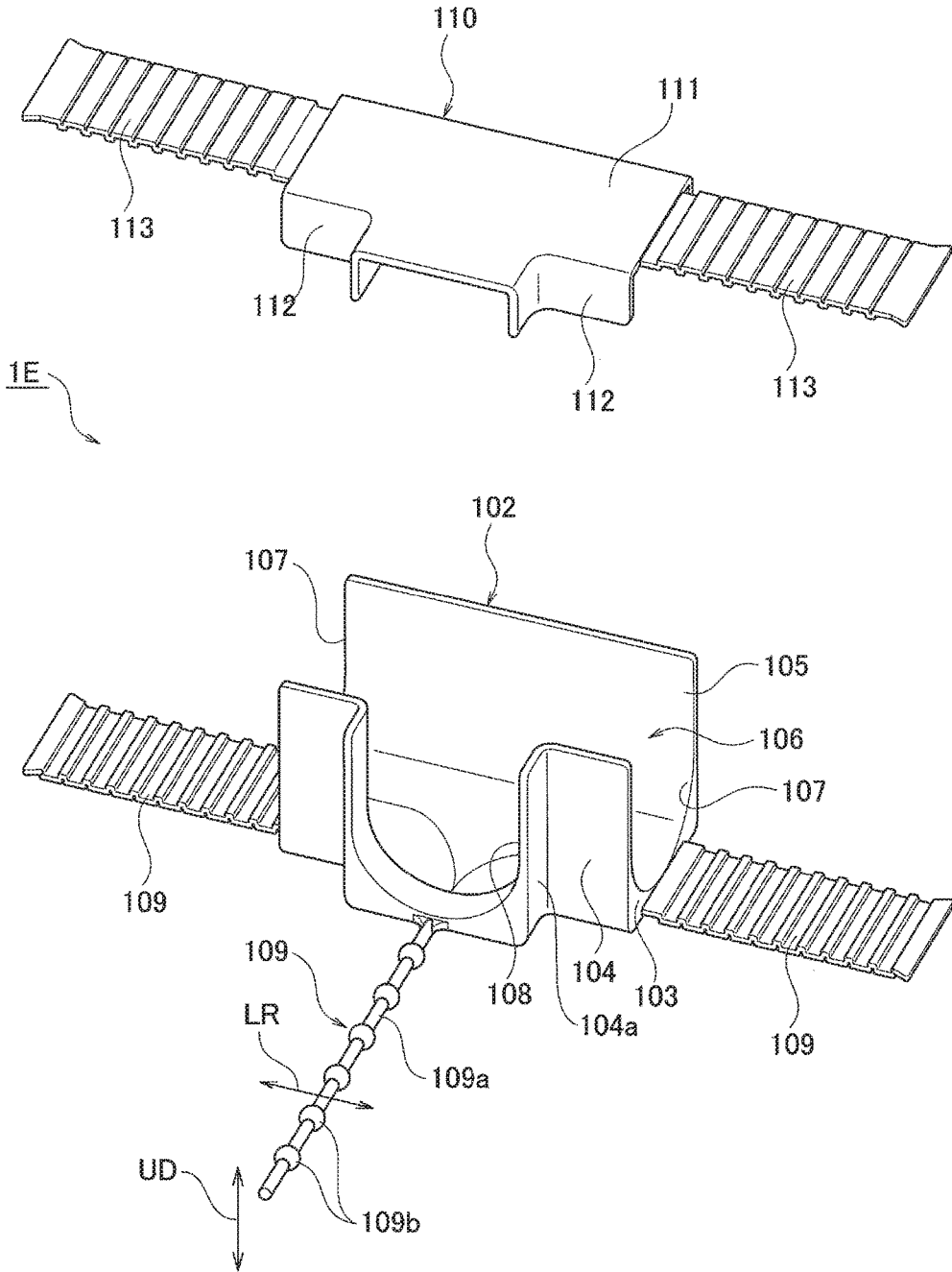


FIG. 50



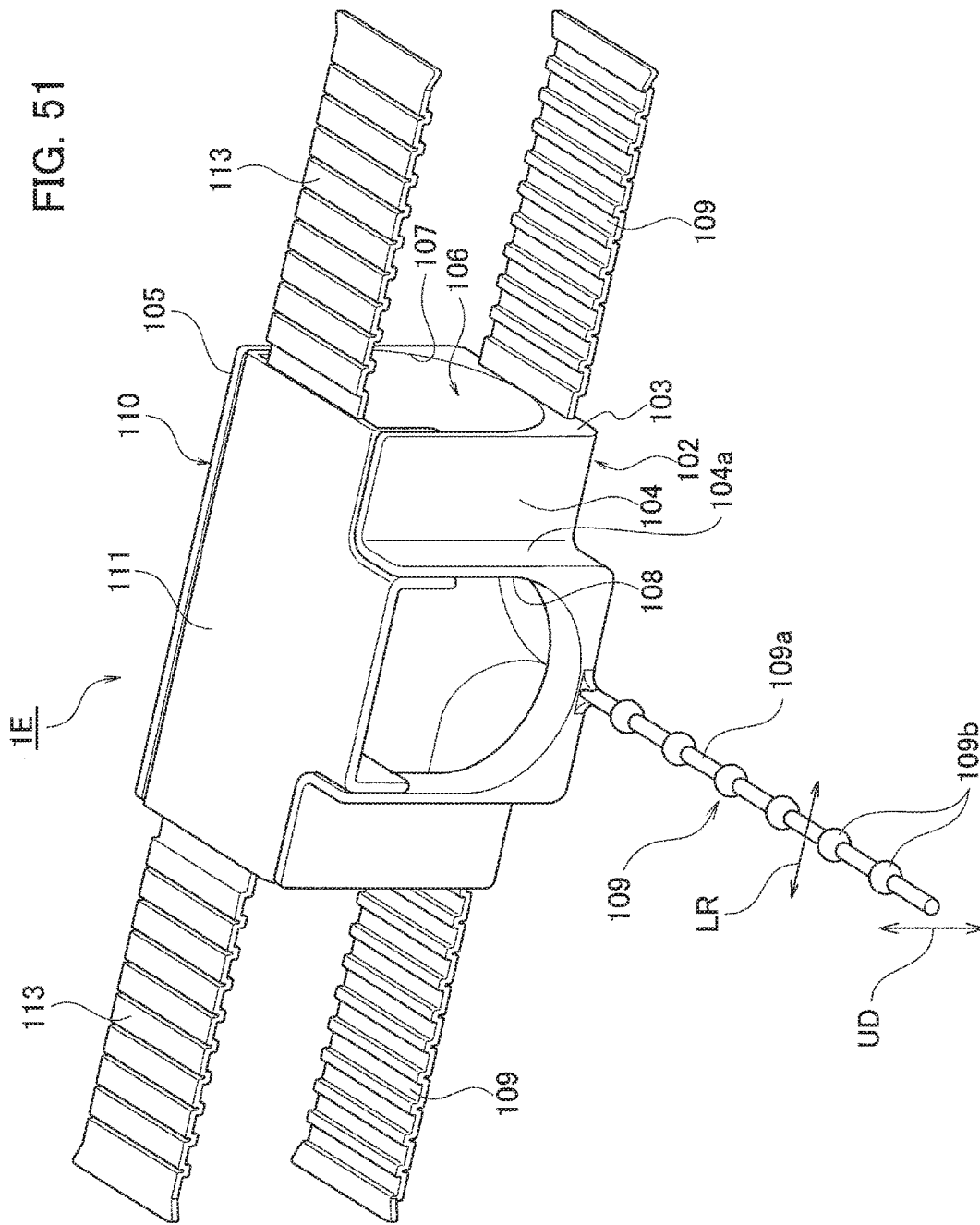


FIG. 52A

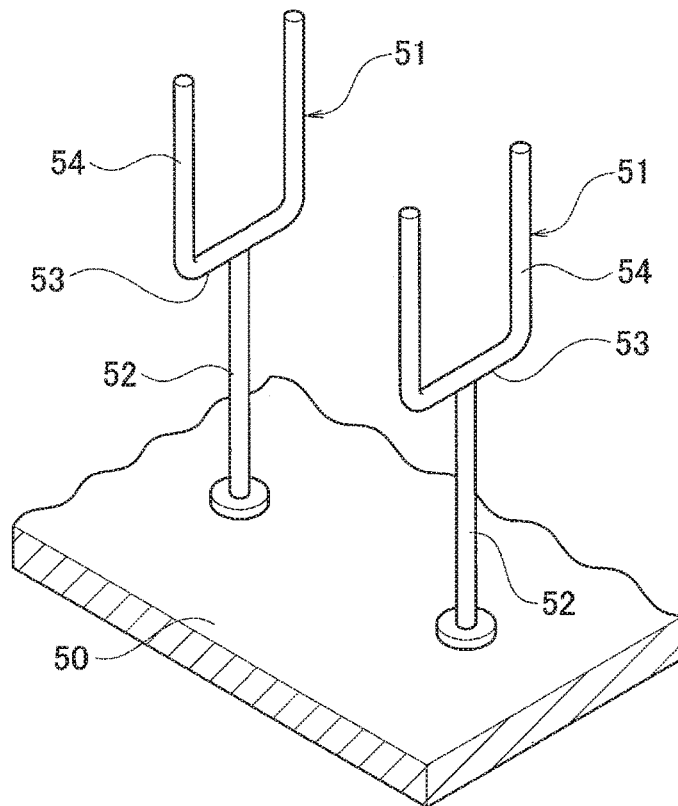
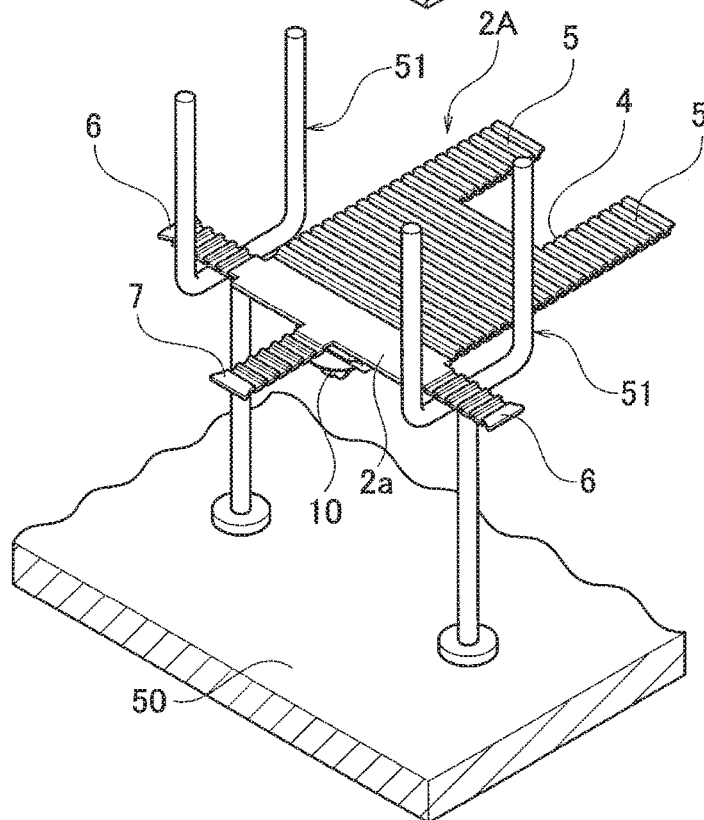
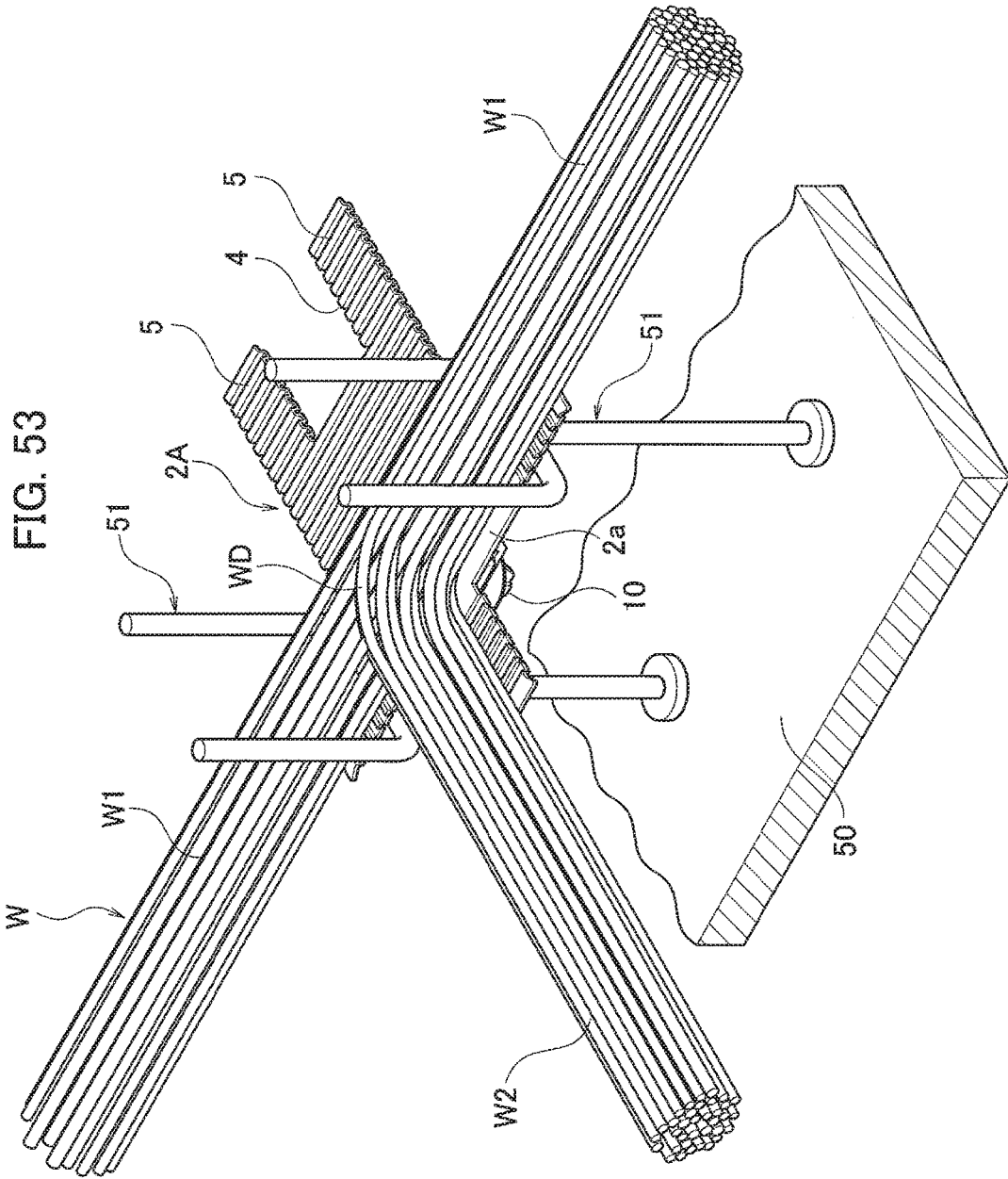


FIG. 52B





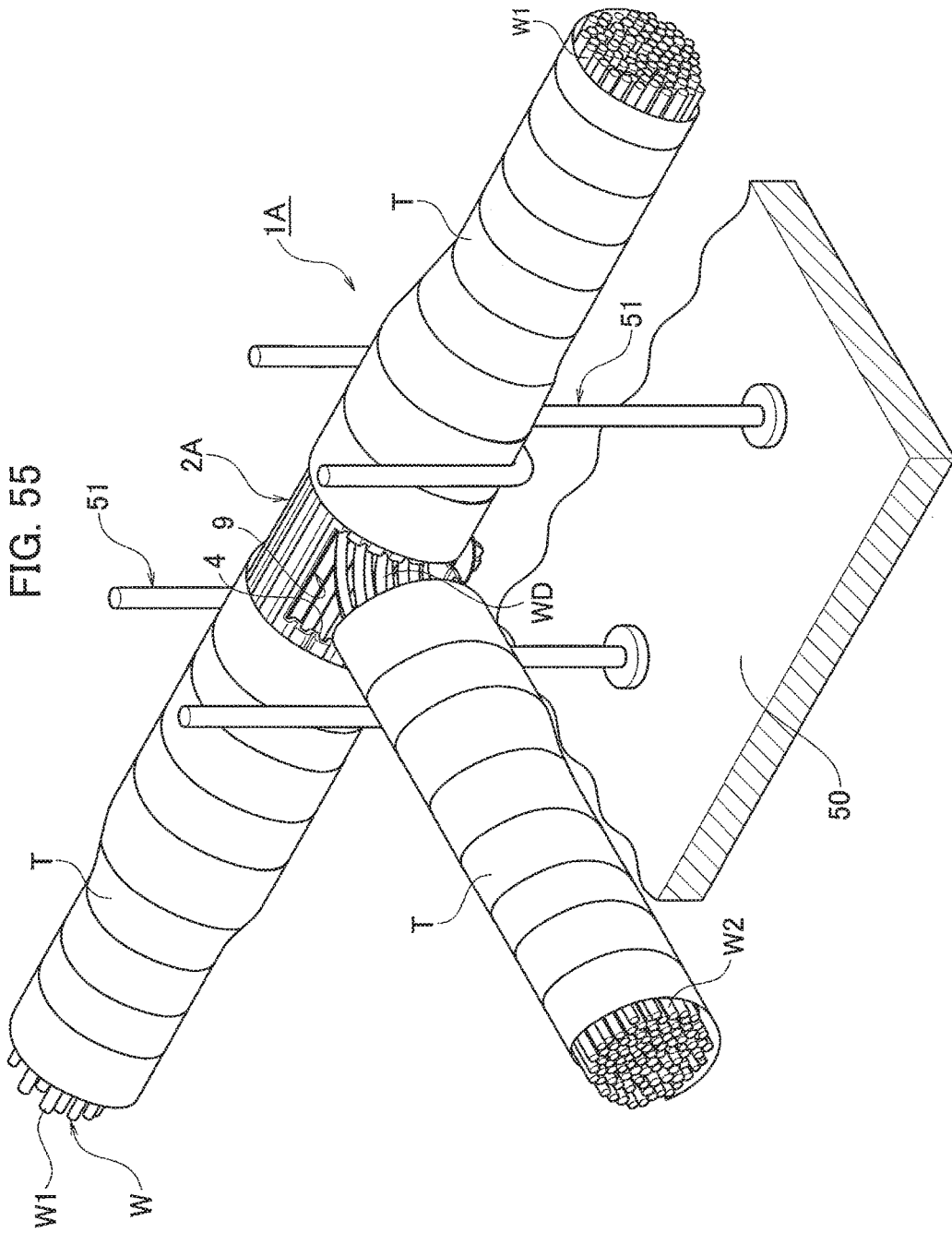
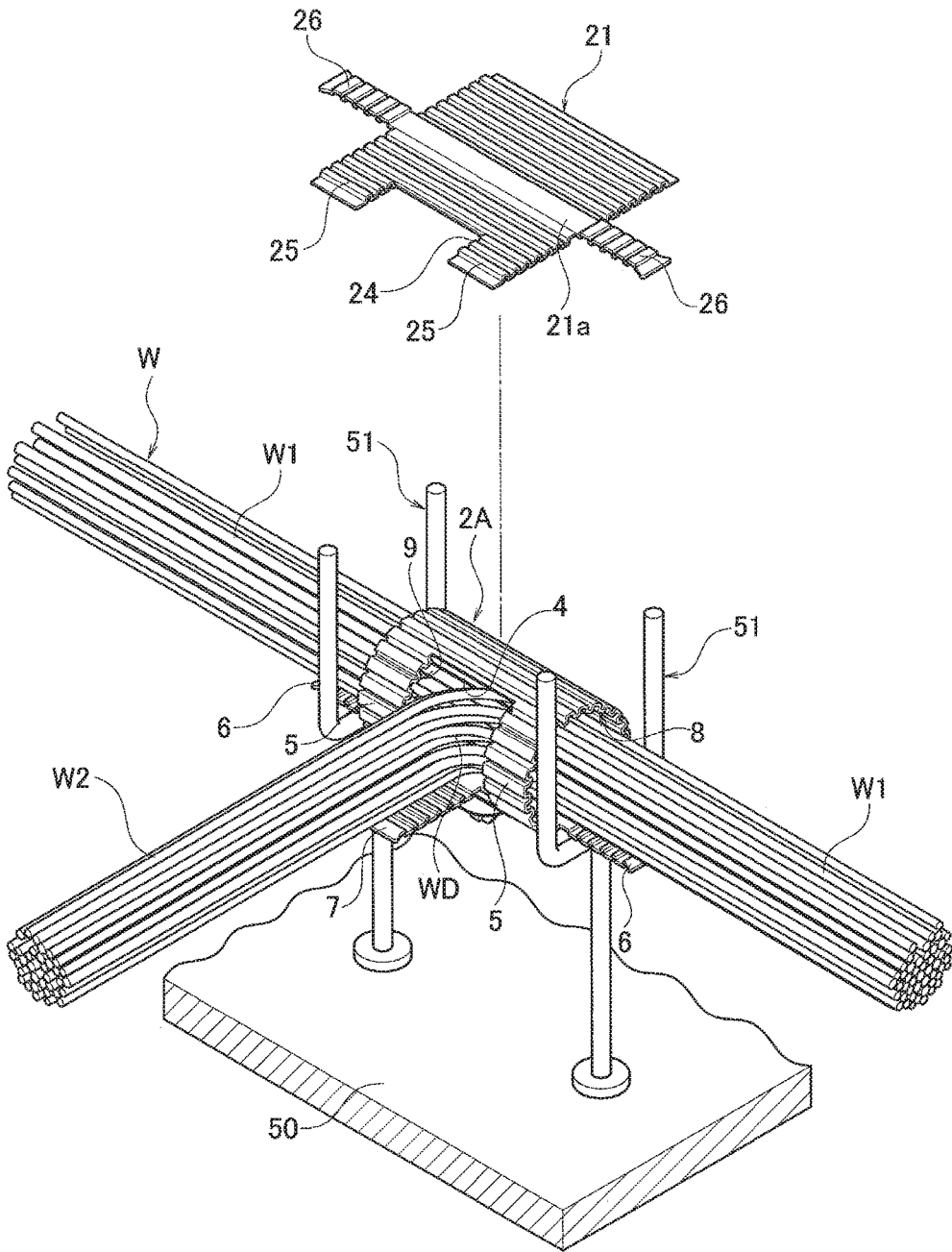
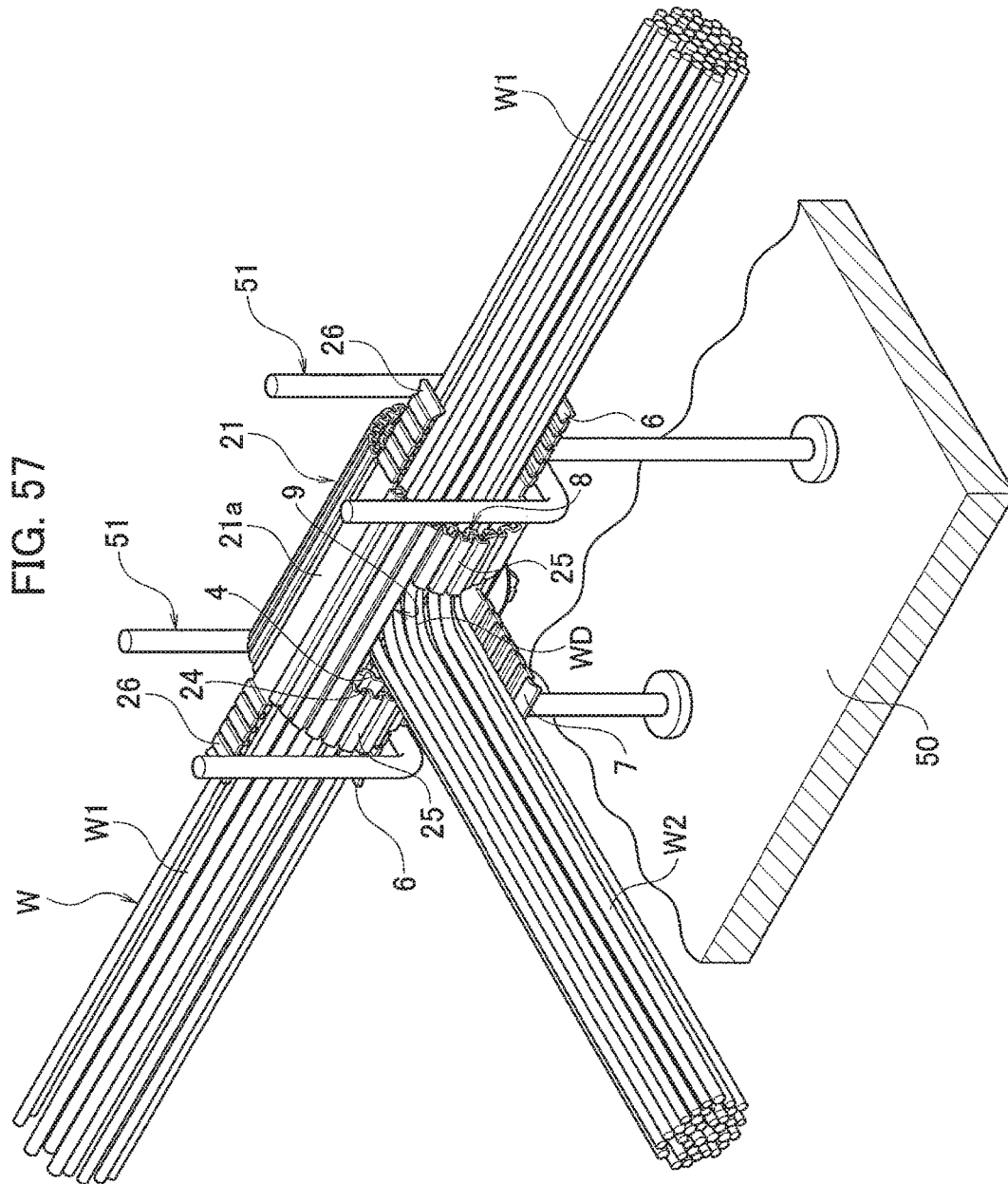


FIG. 56





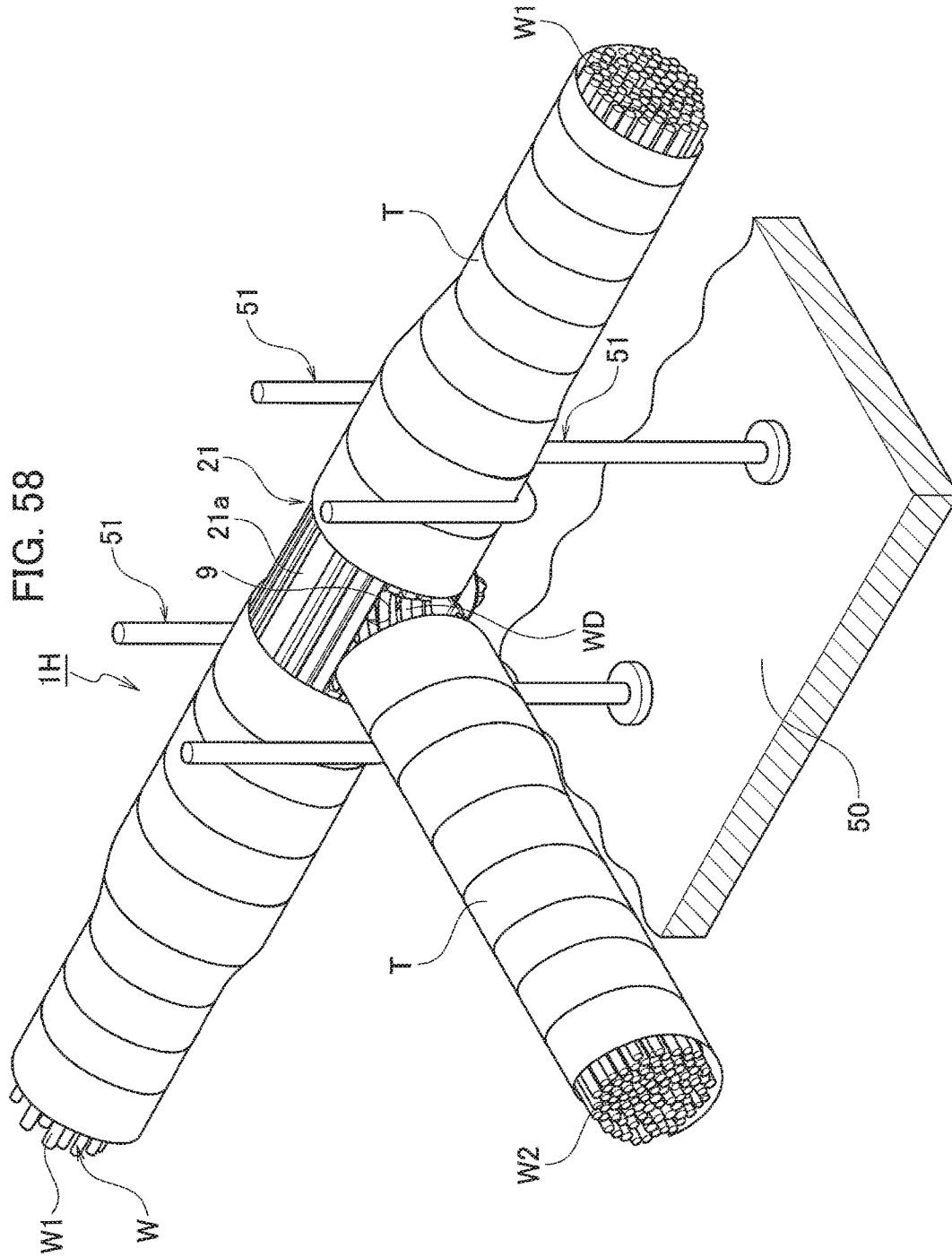
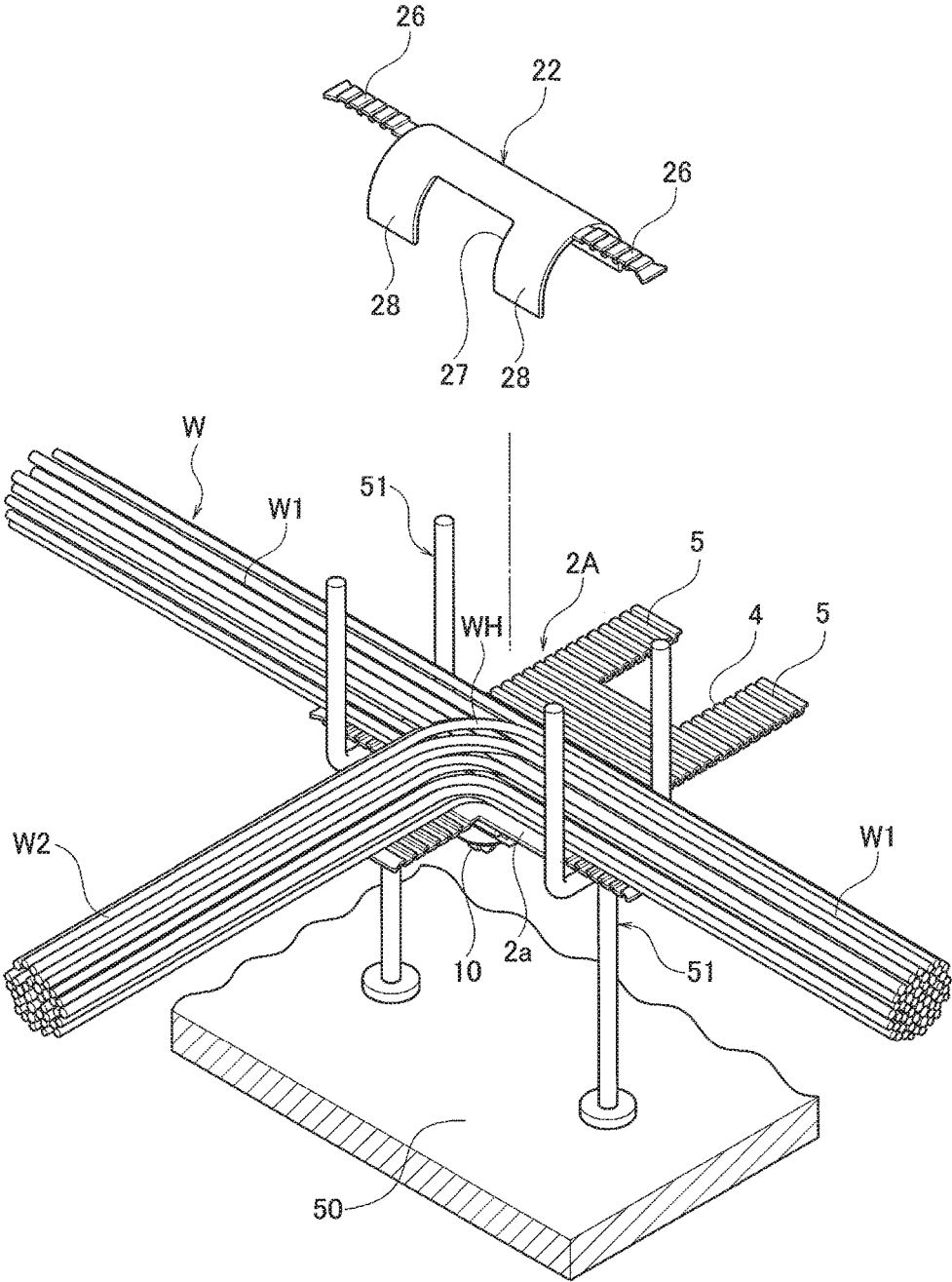
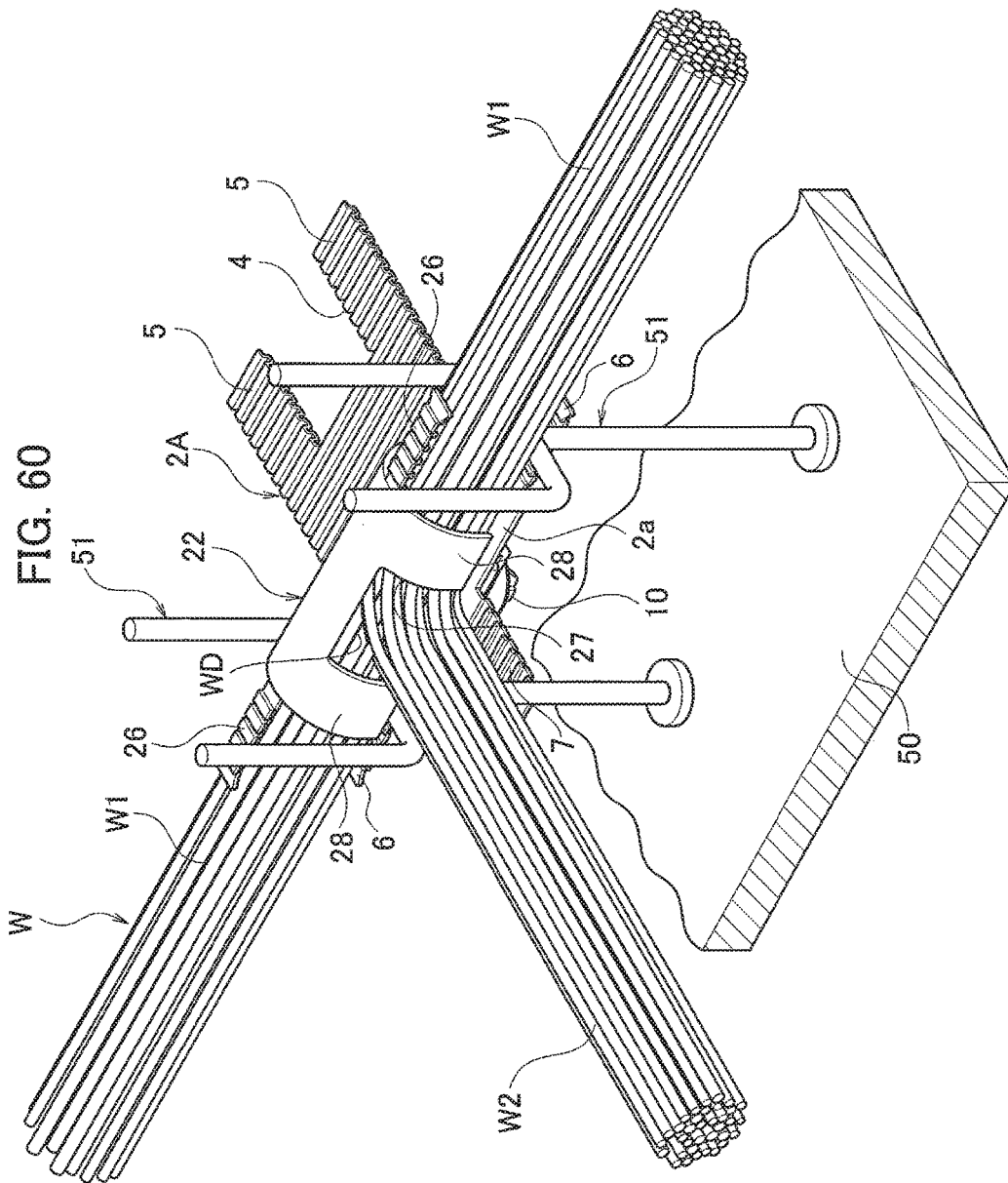
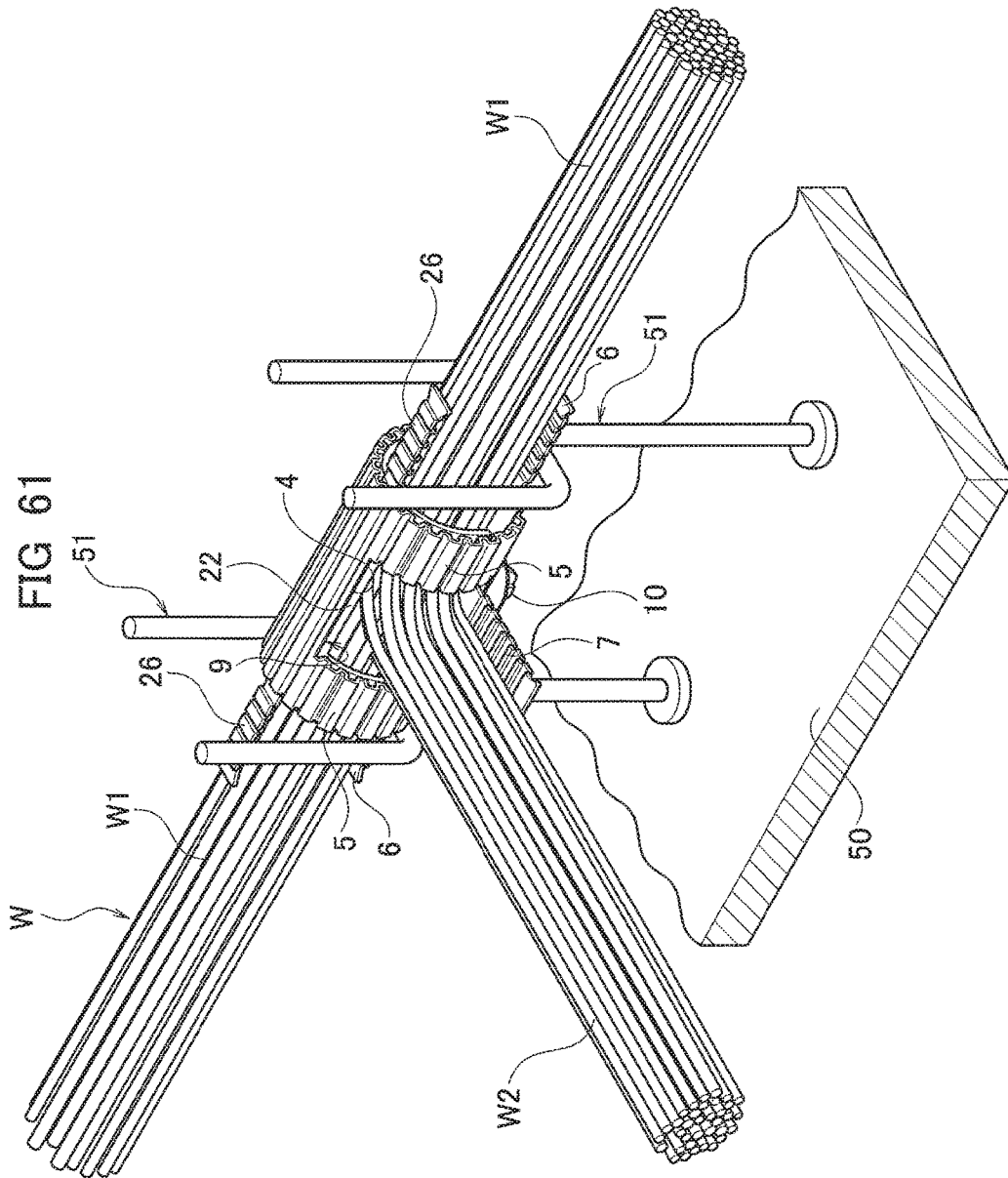


FIG. 59







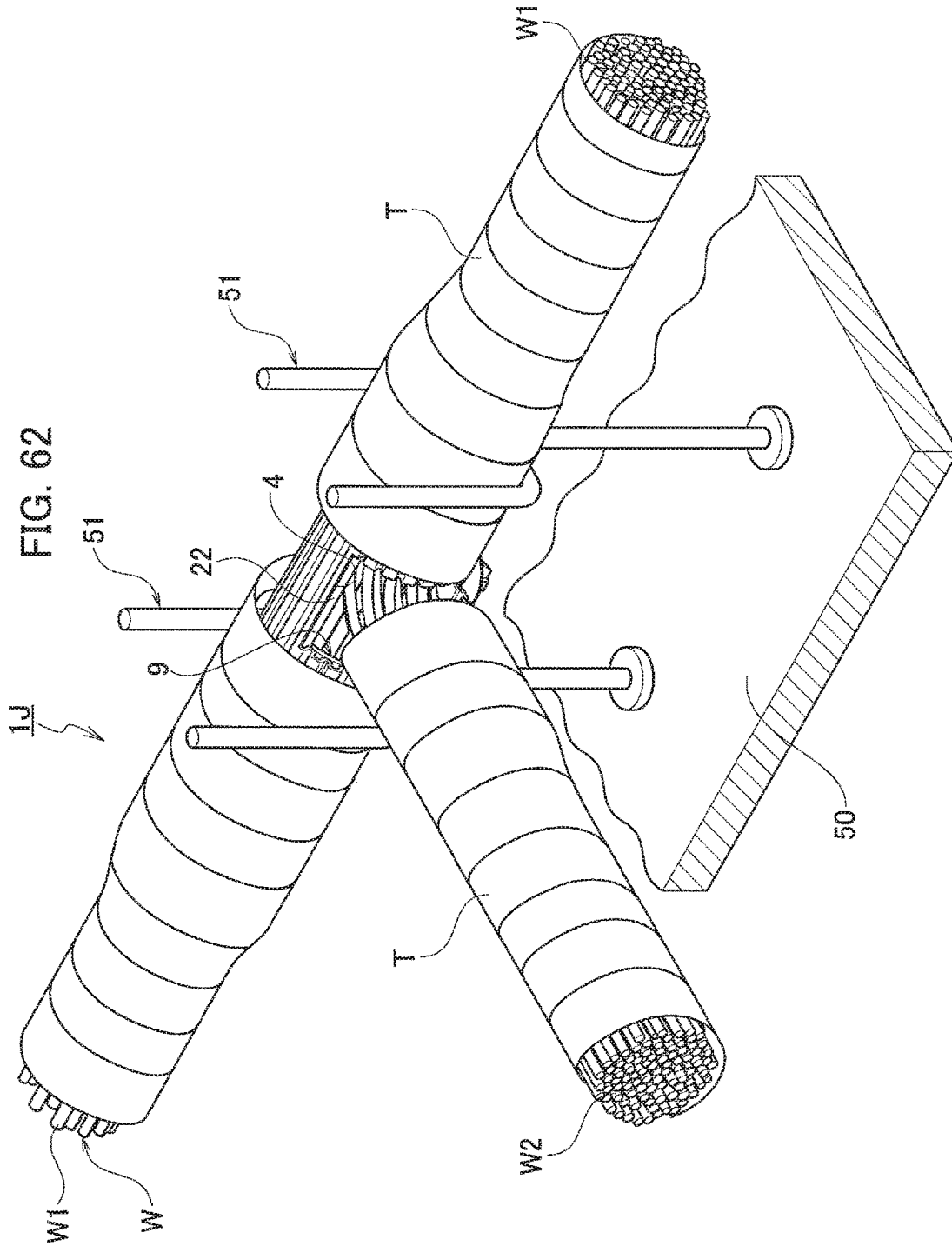
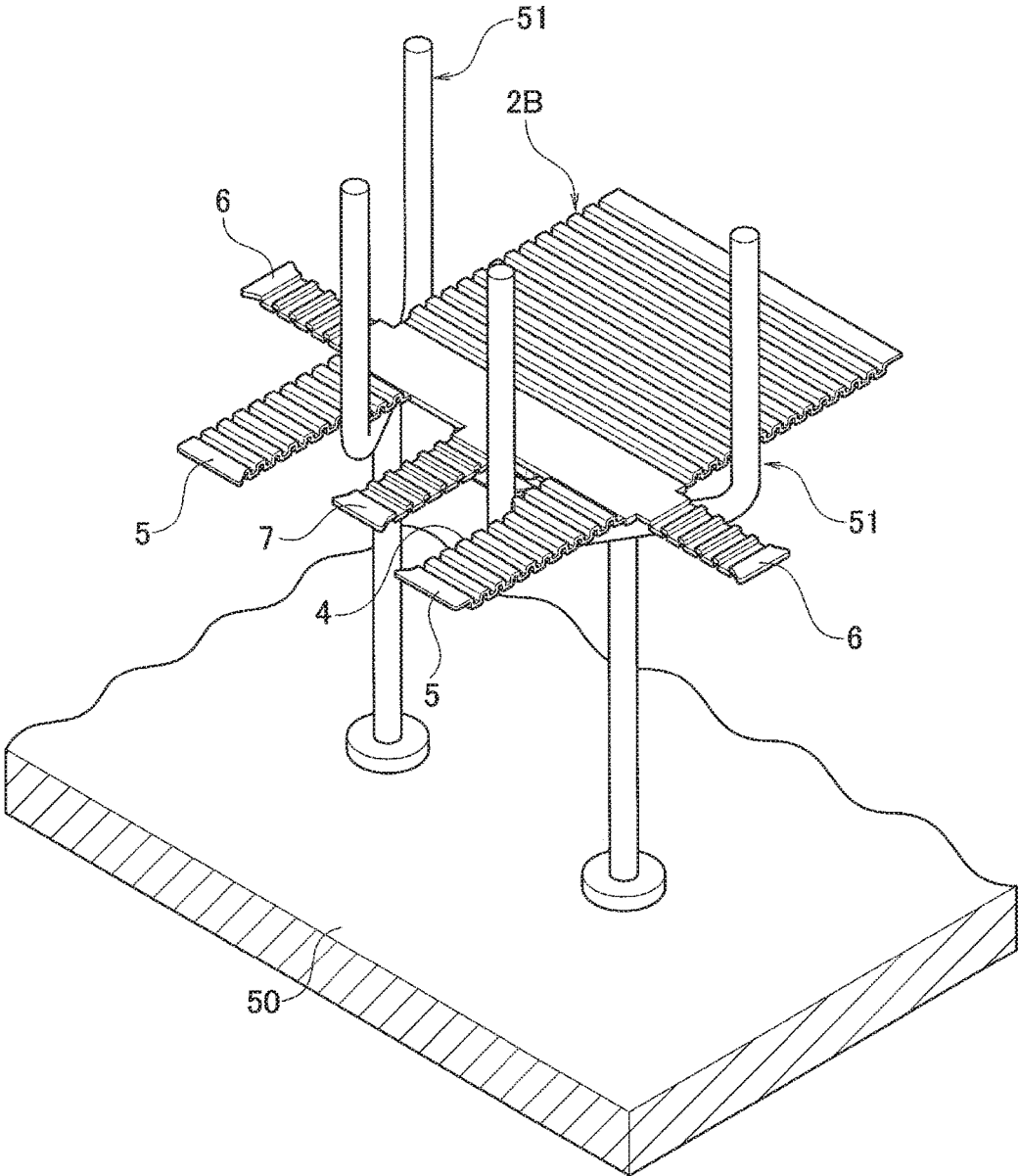
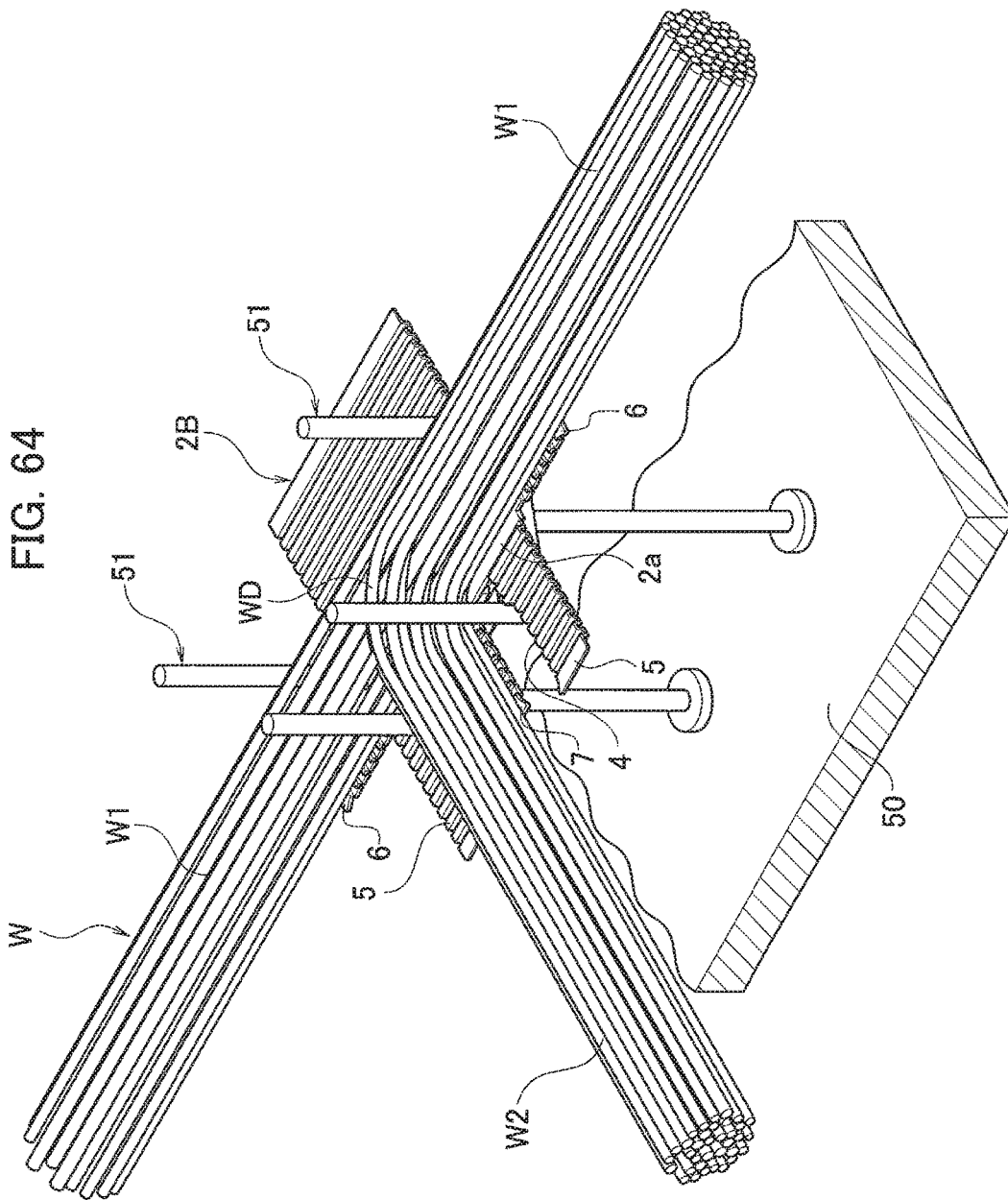
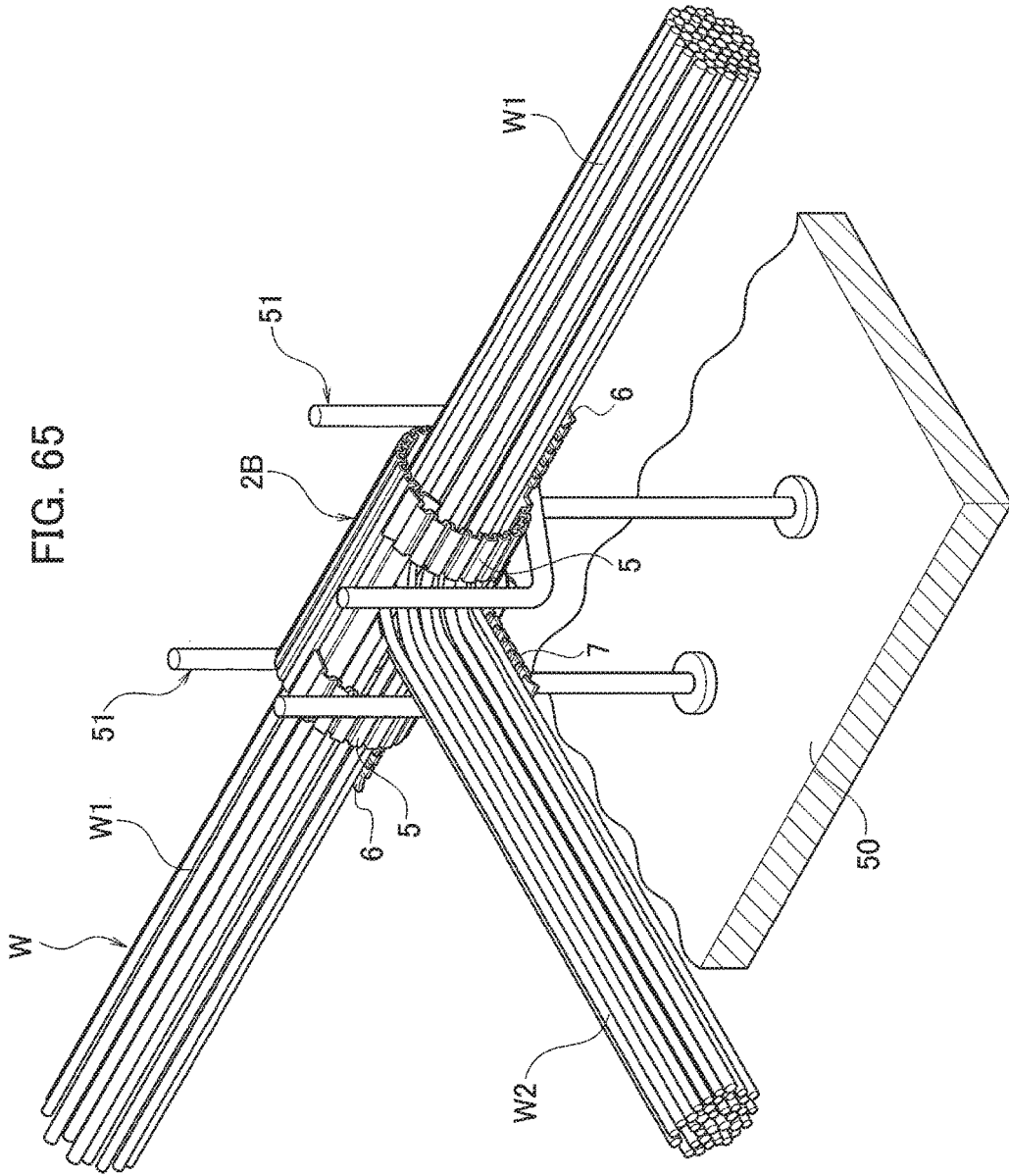


FIG. 63







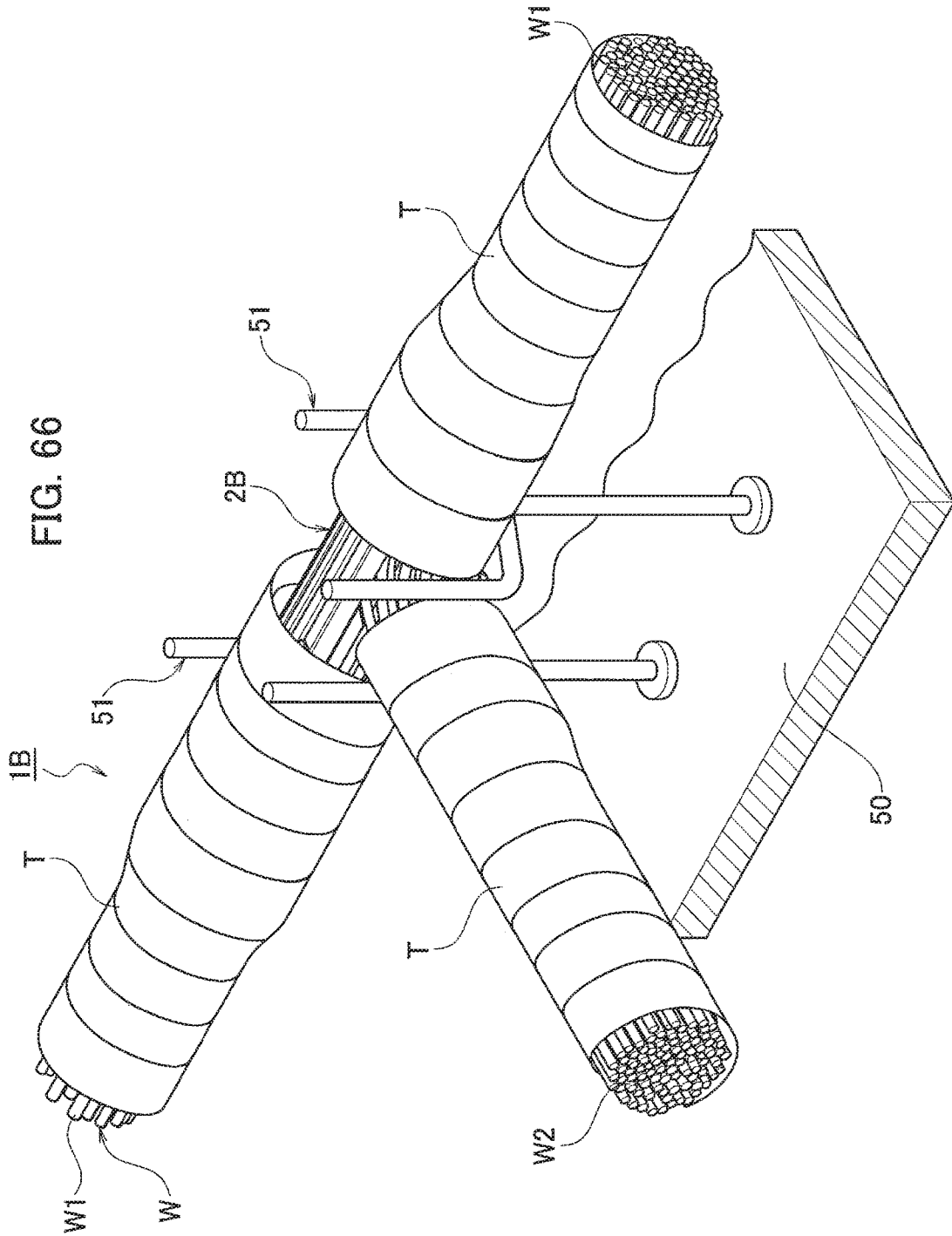
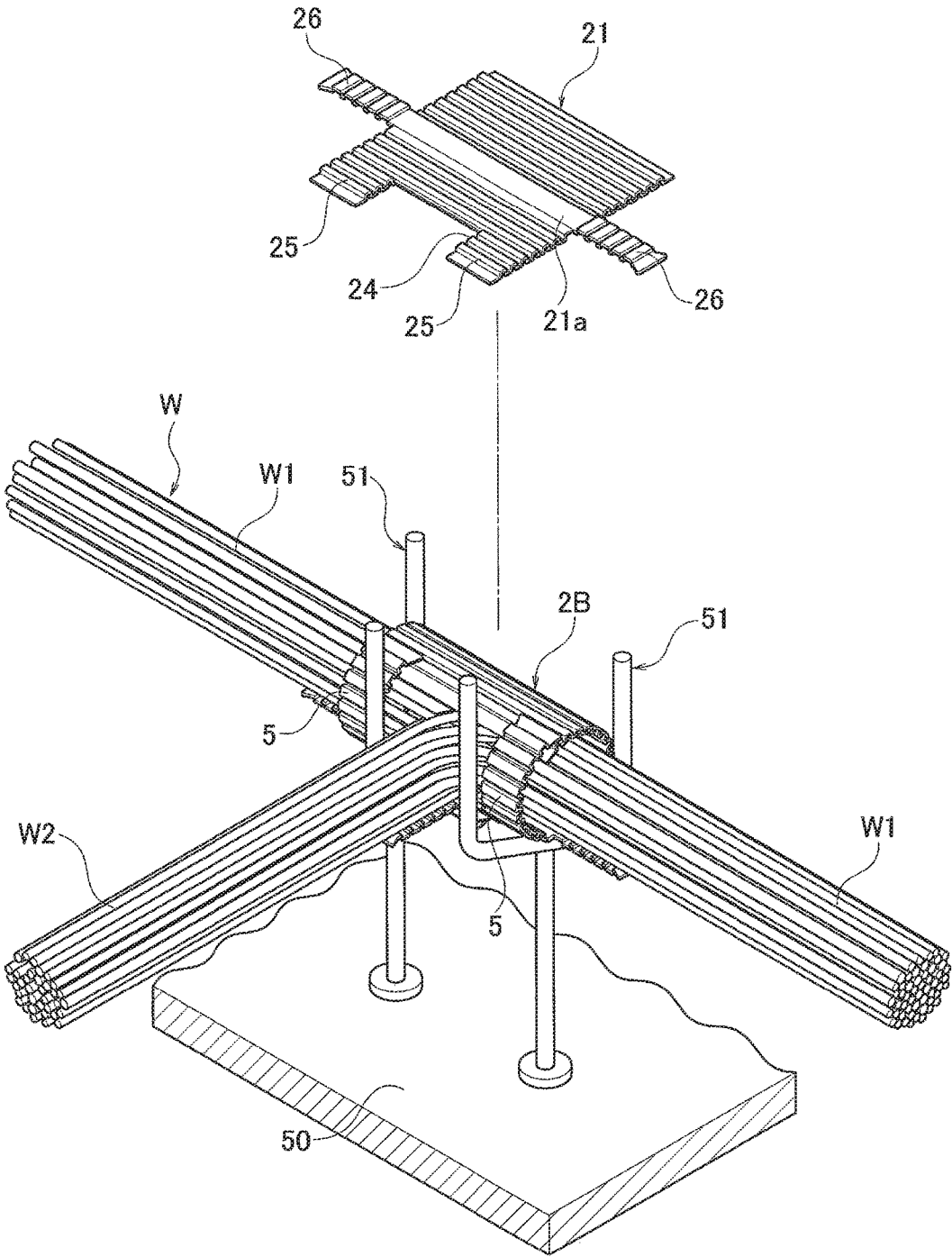
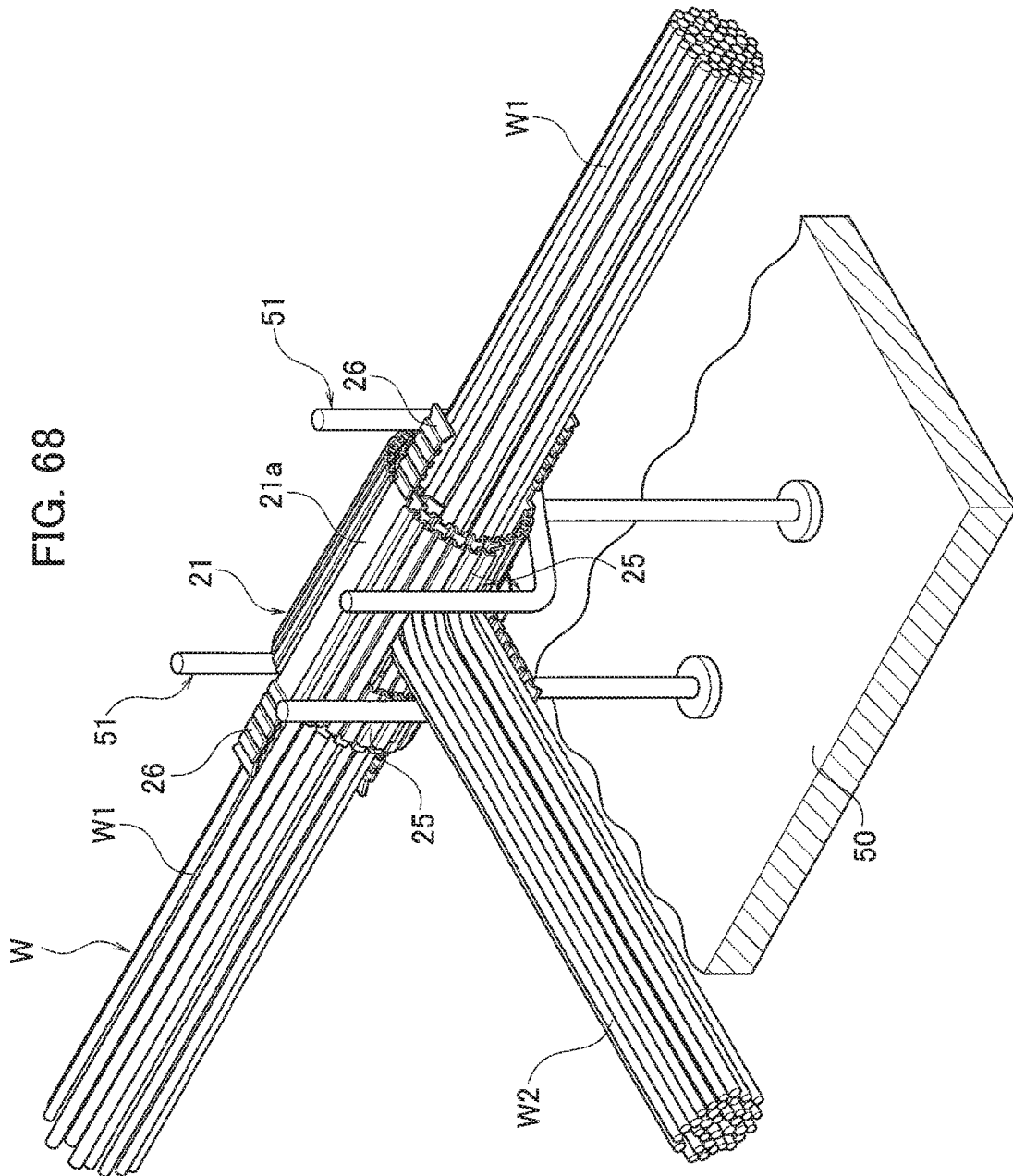


FIG. 67





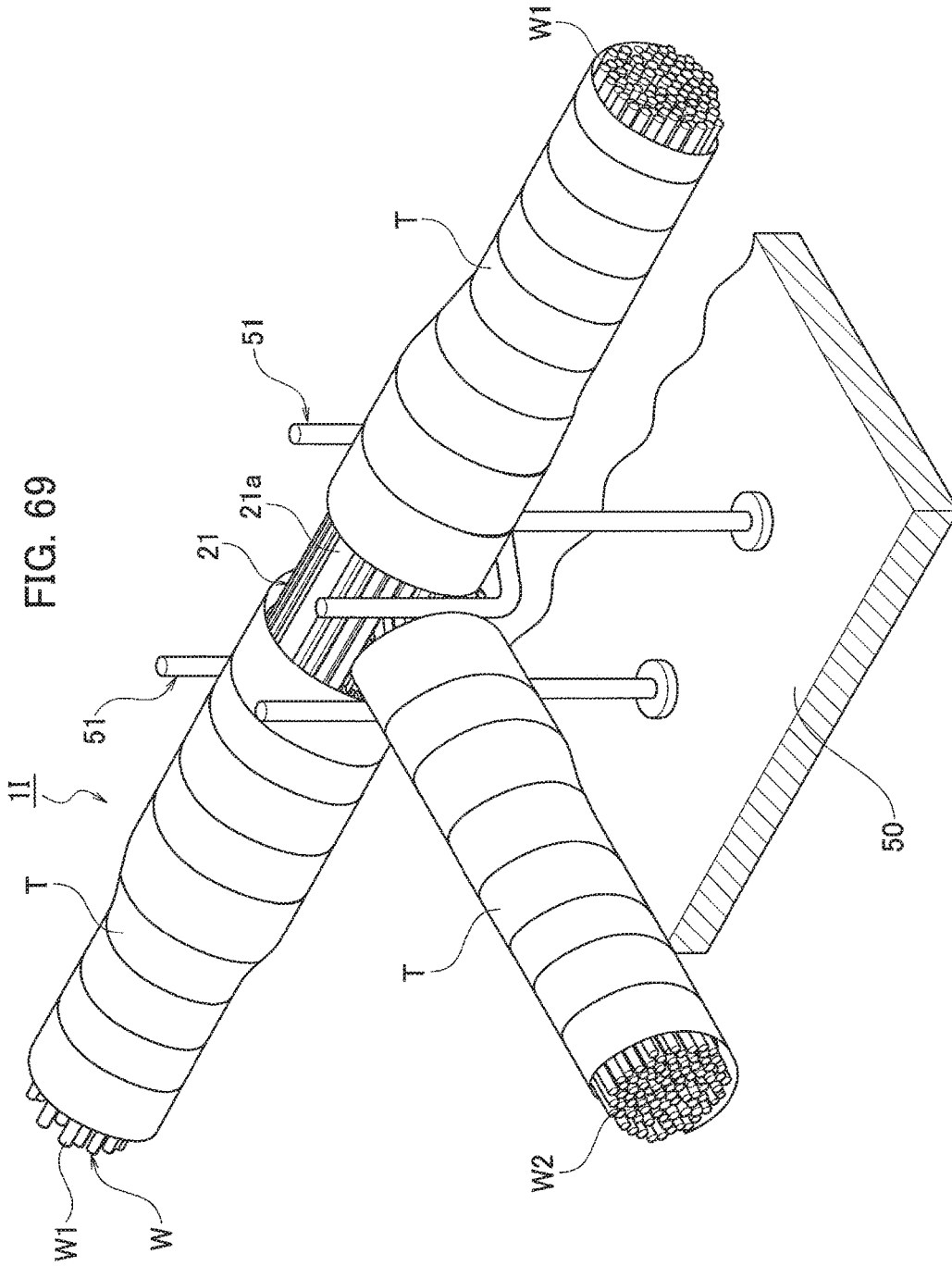
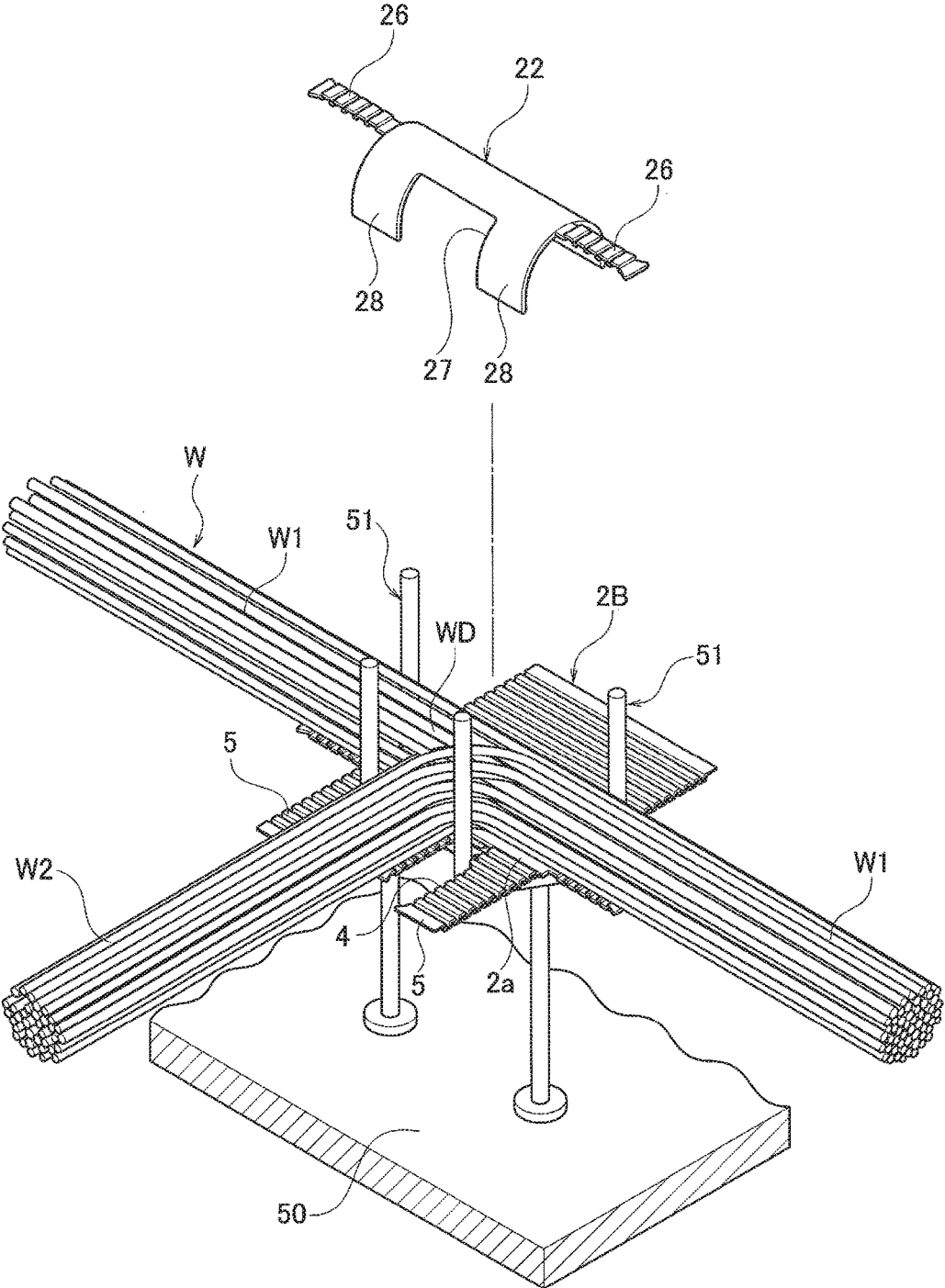


FIG. 70



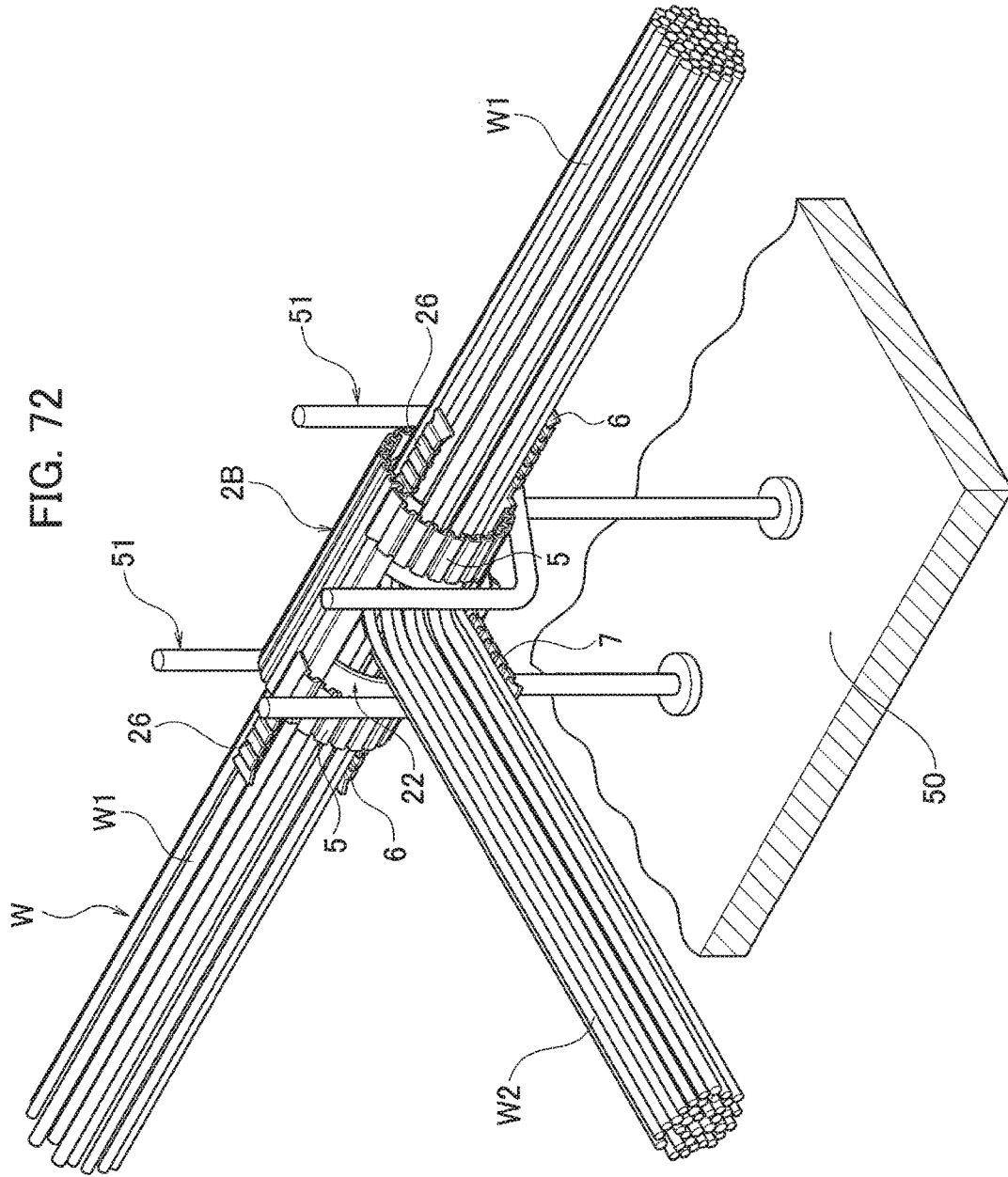
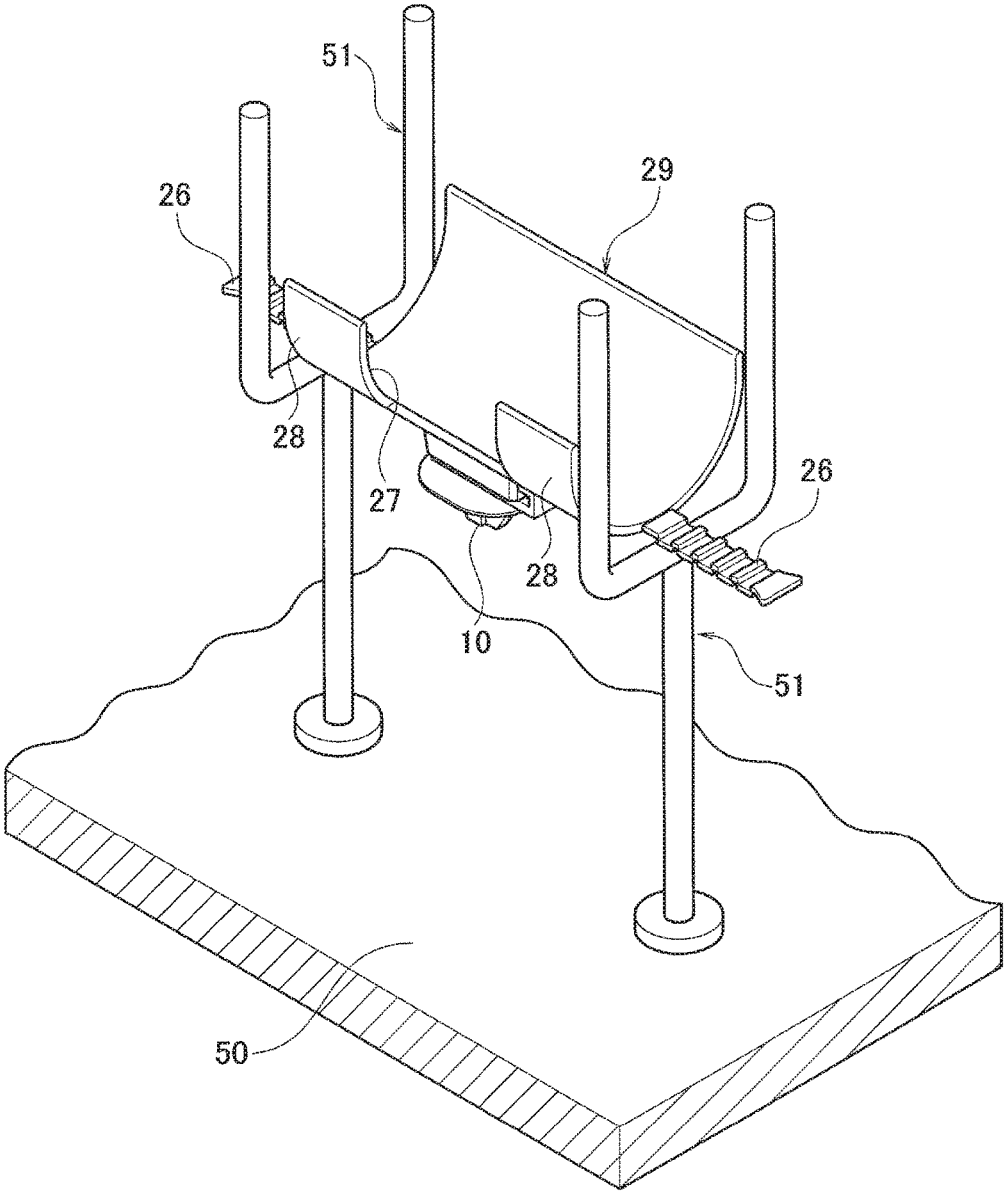


FIG. 74



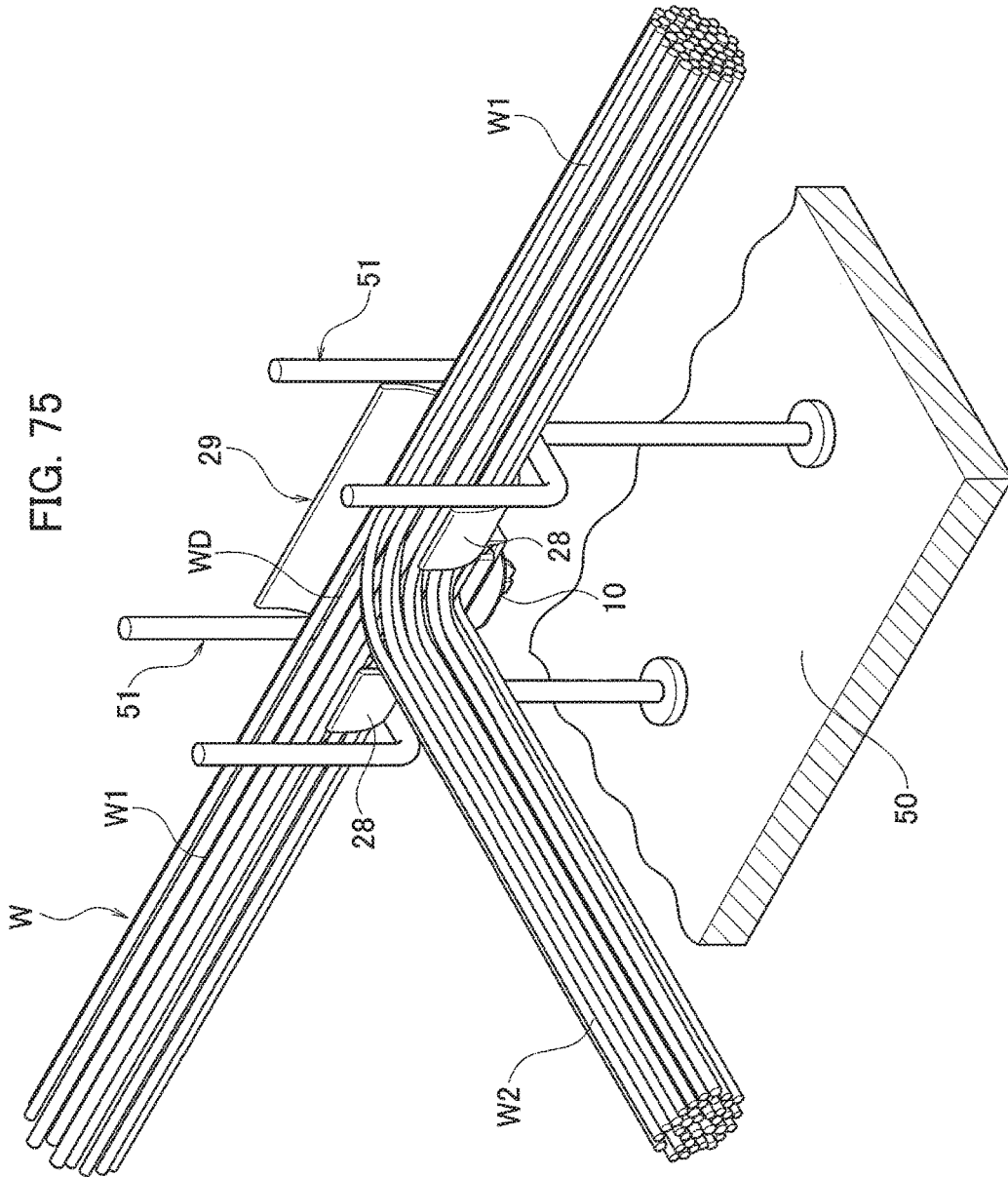
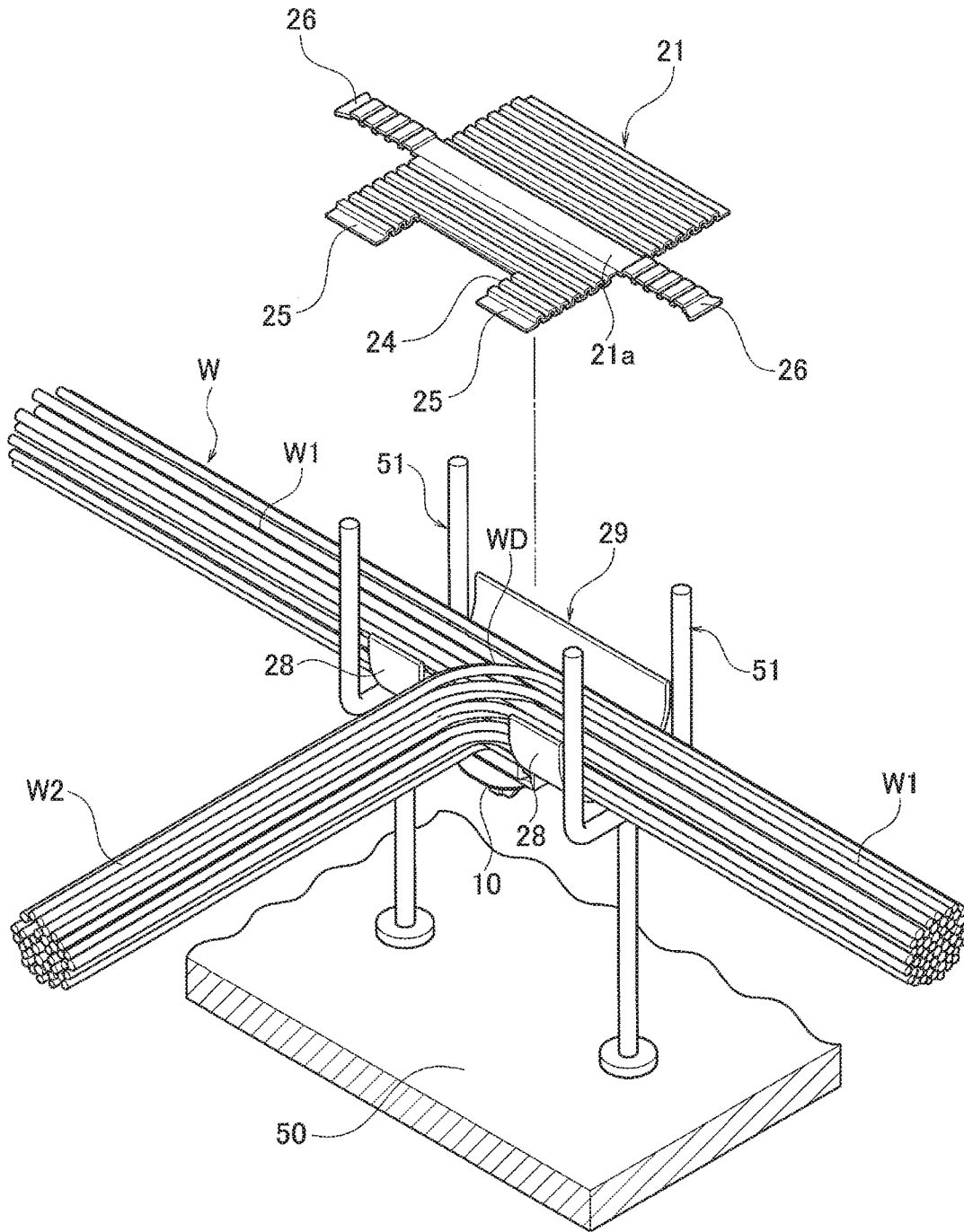
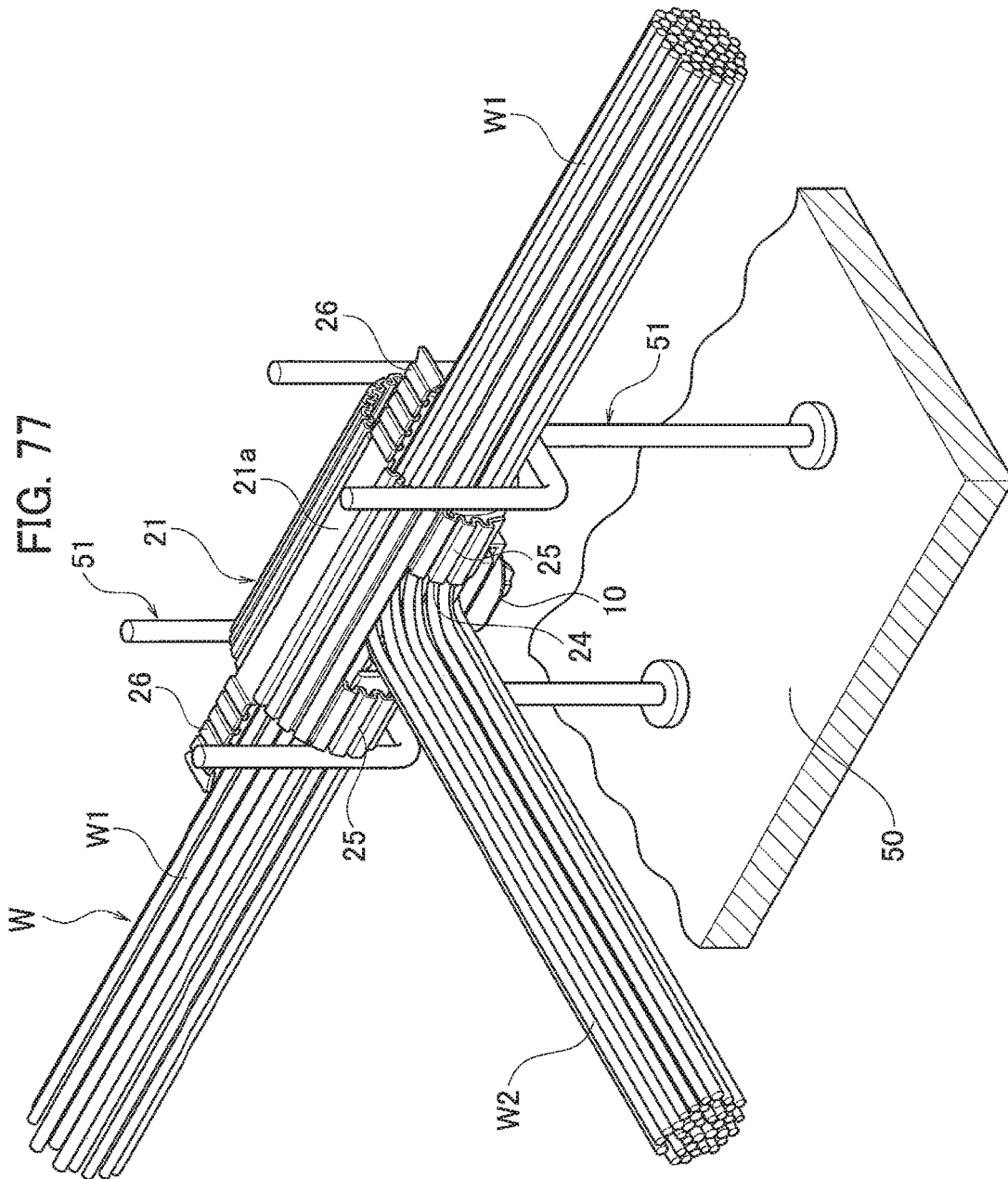


FIG. 76





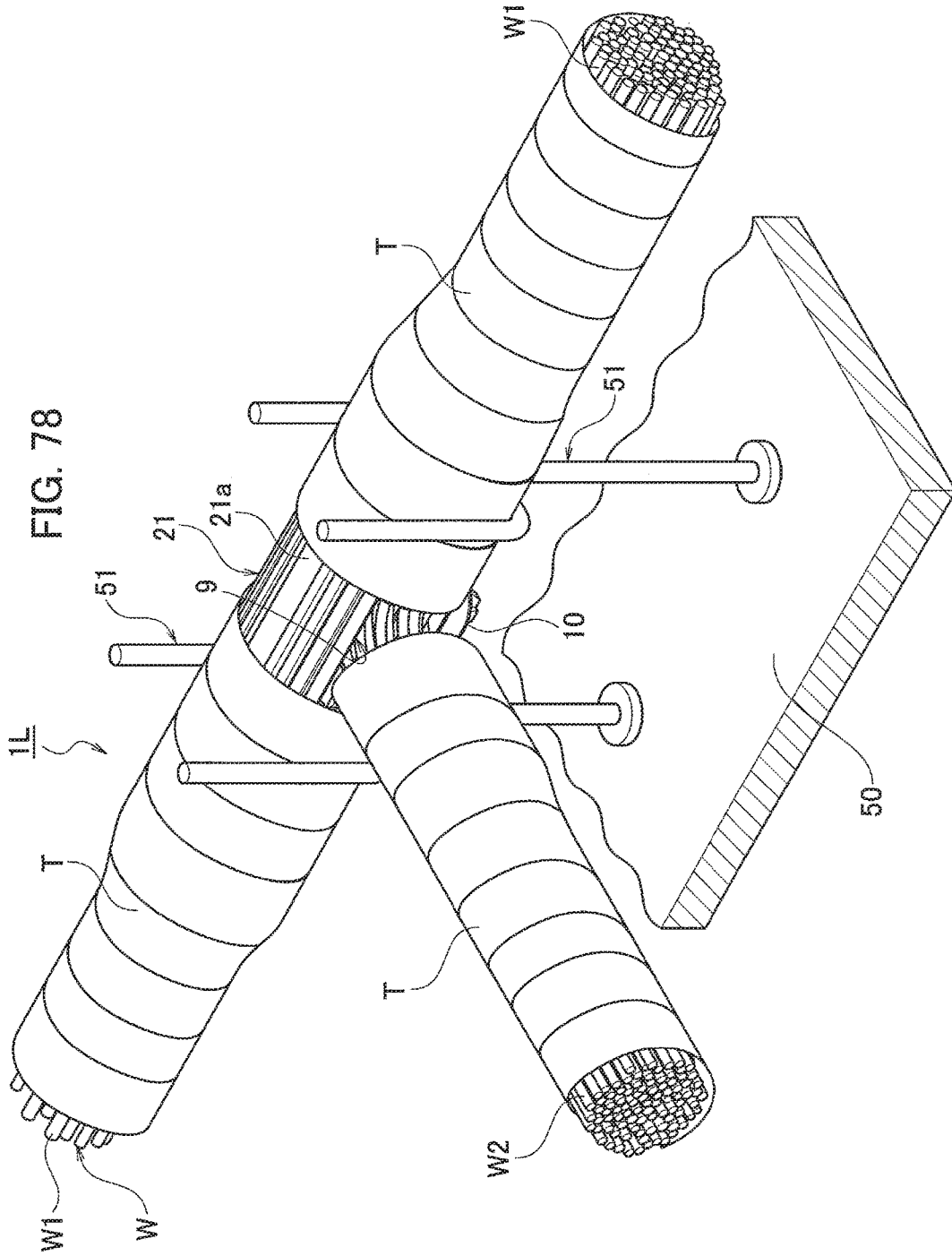
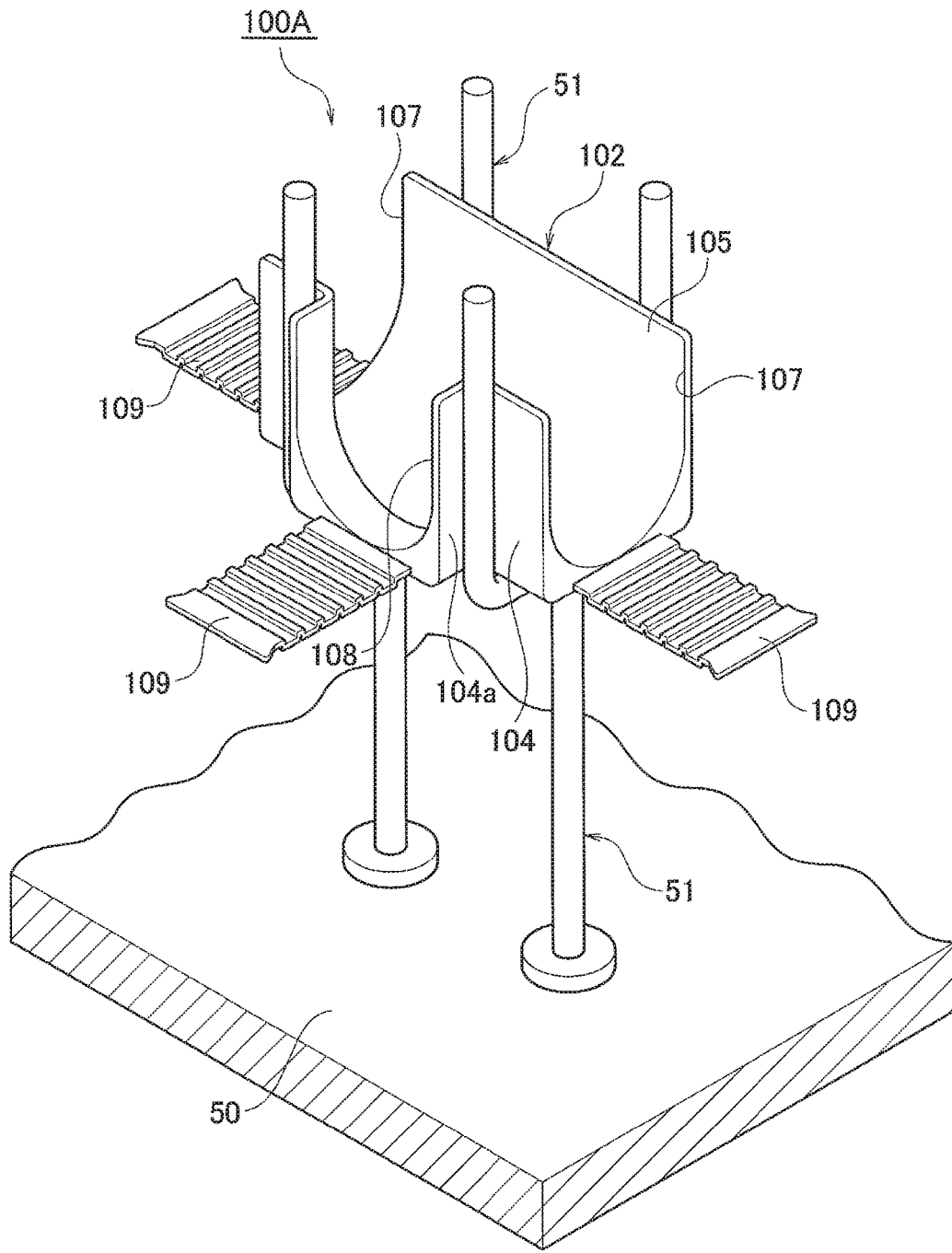
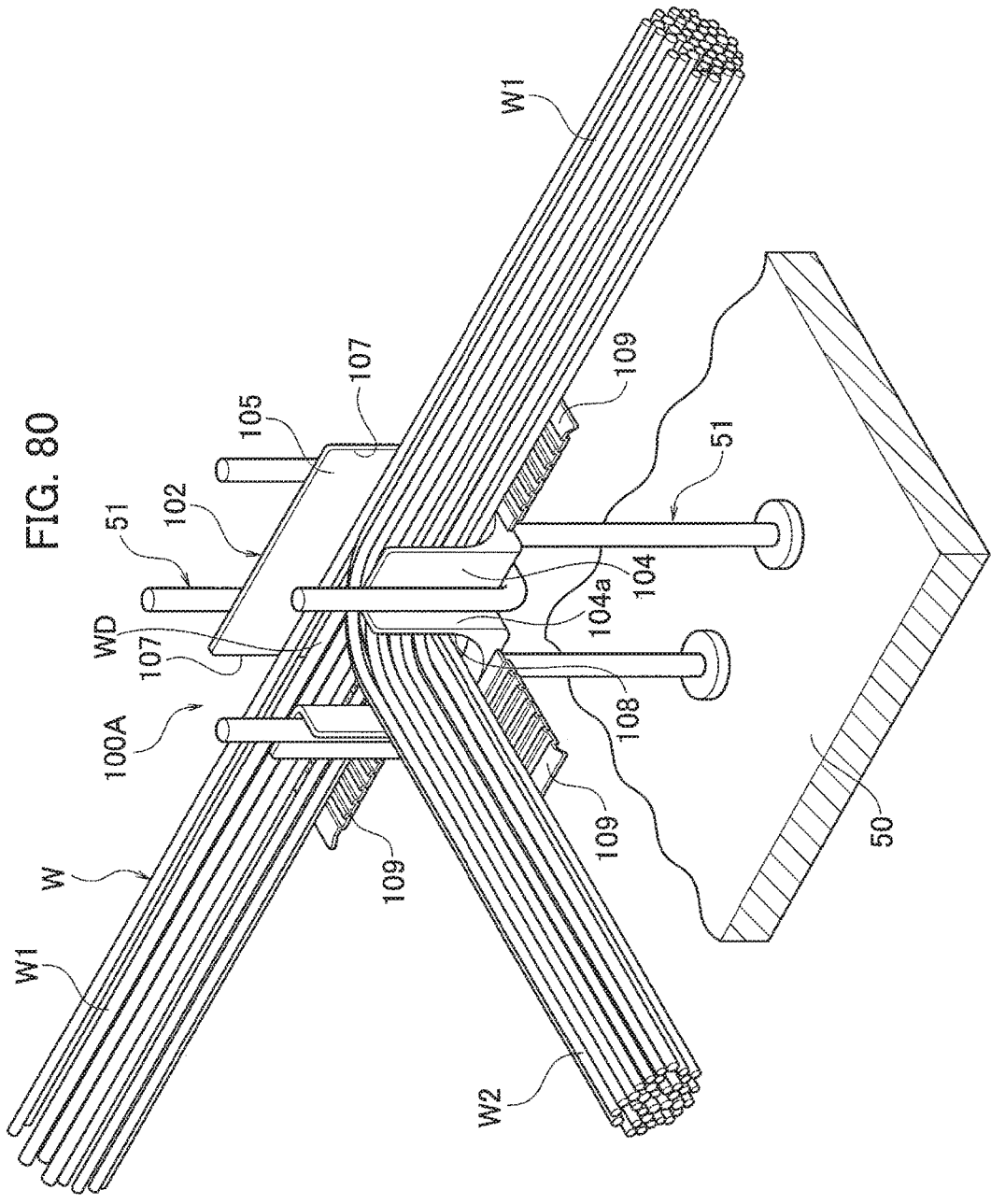
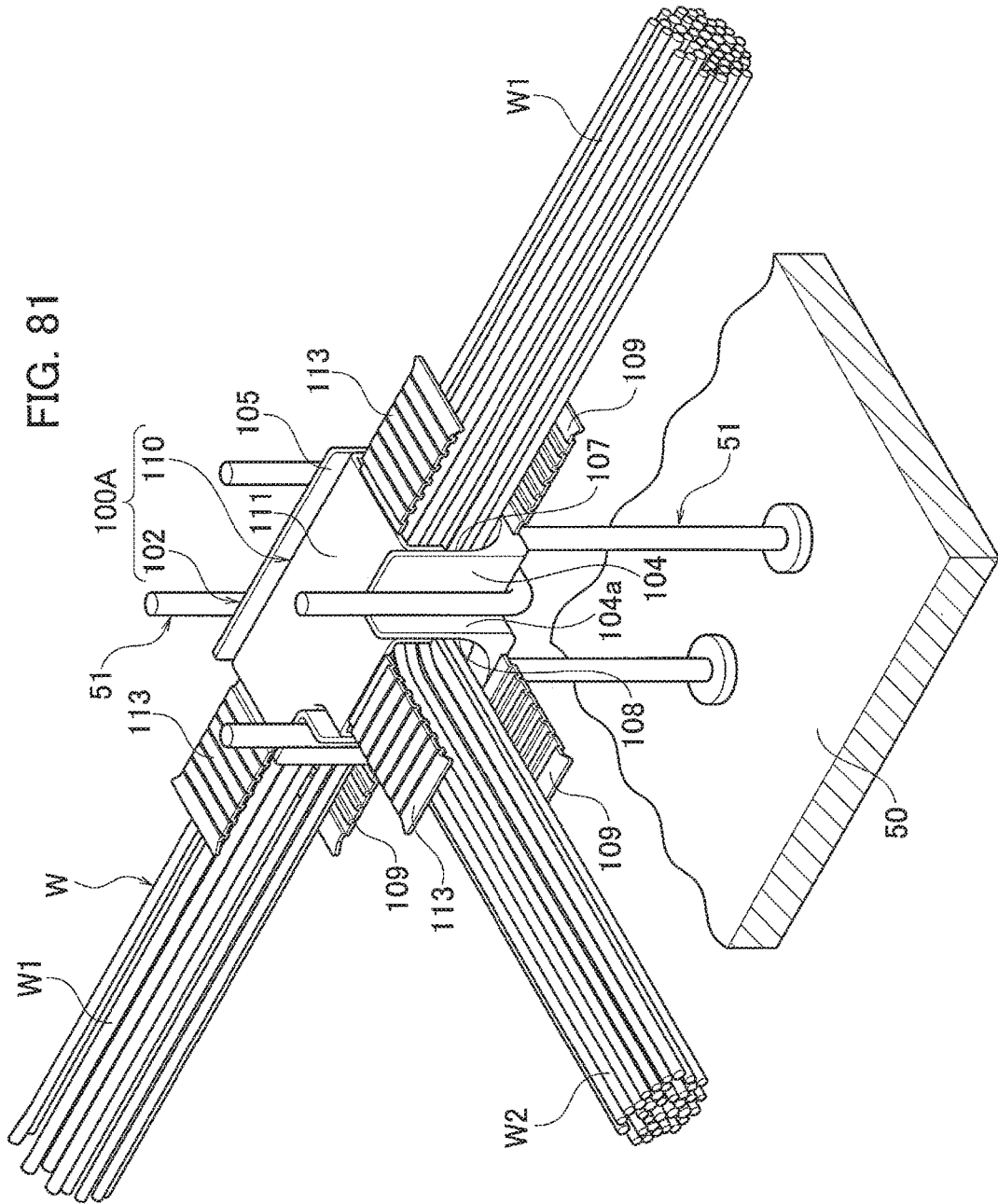
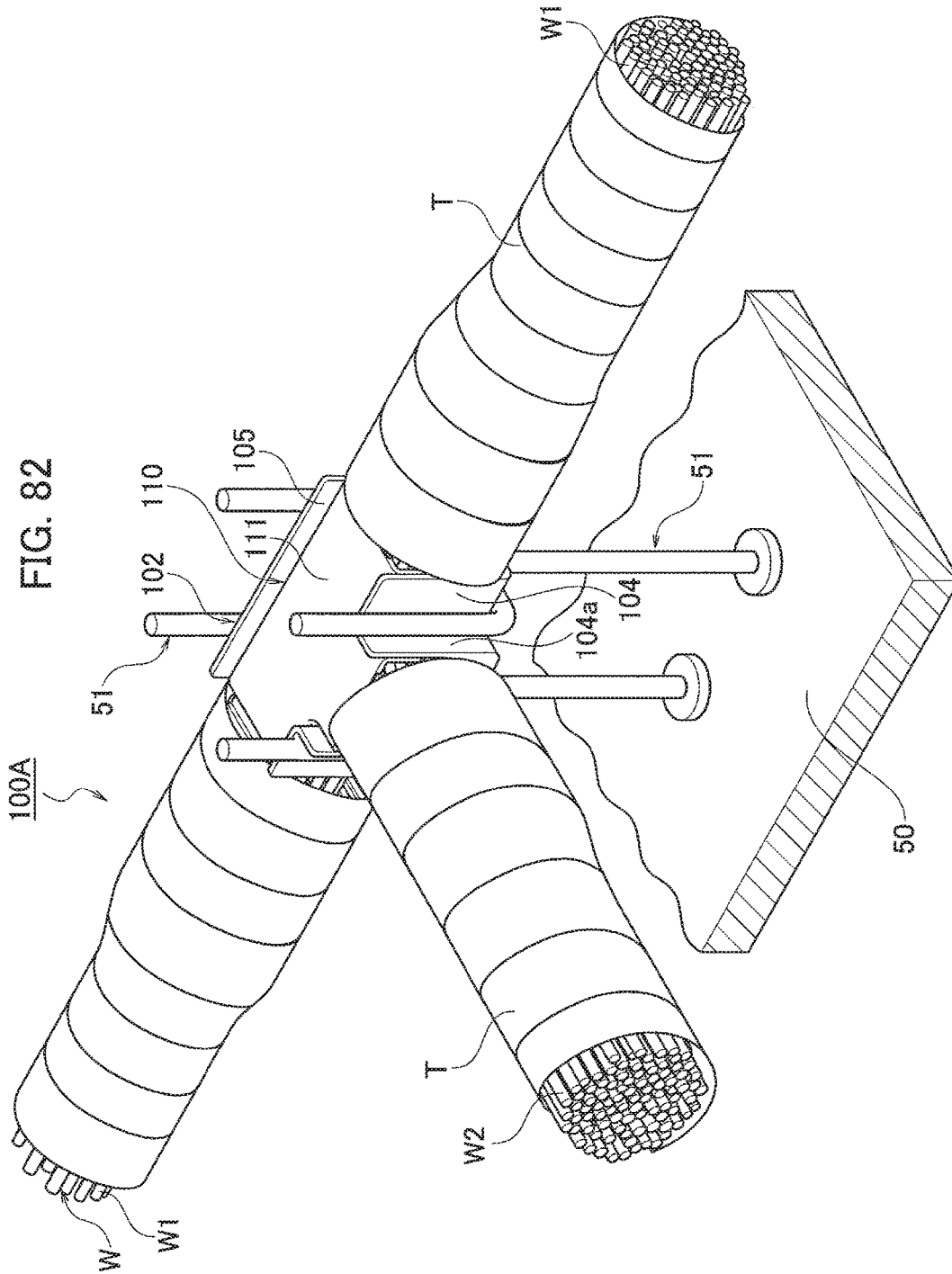


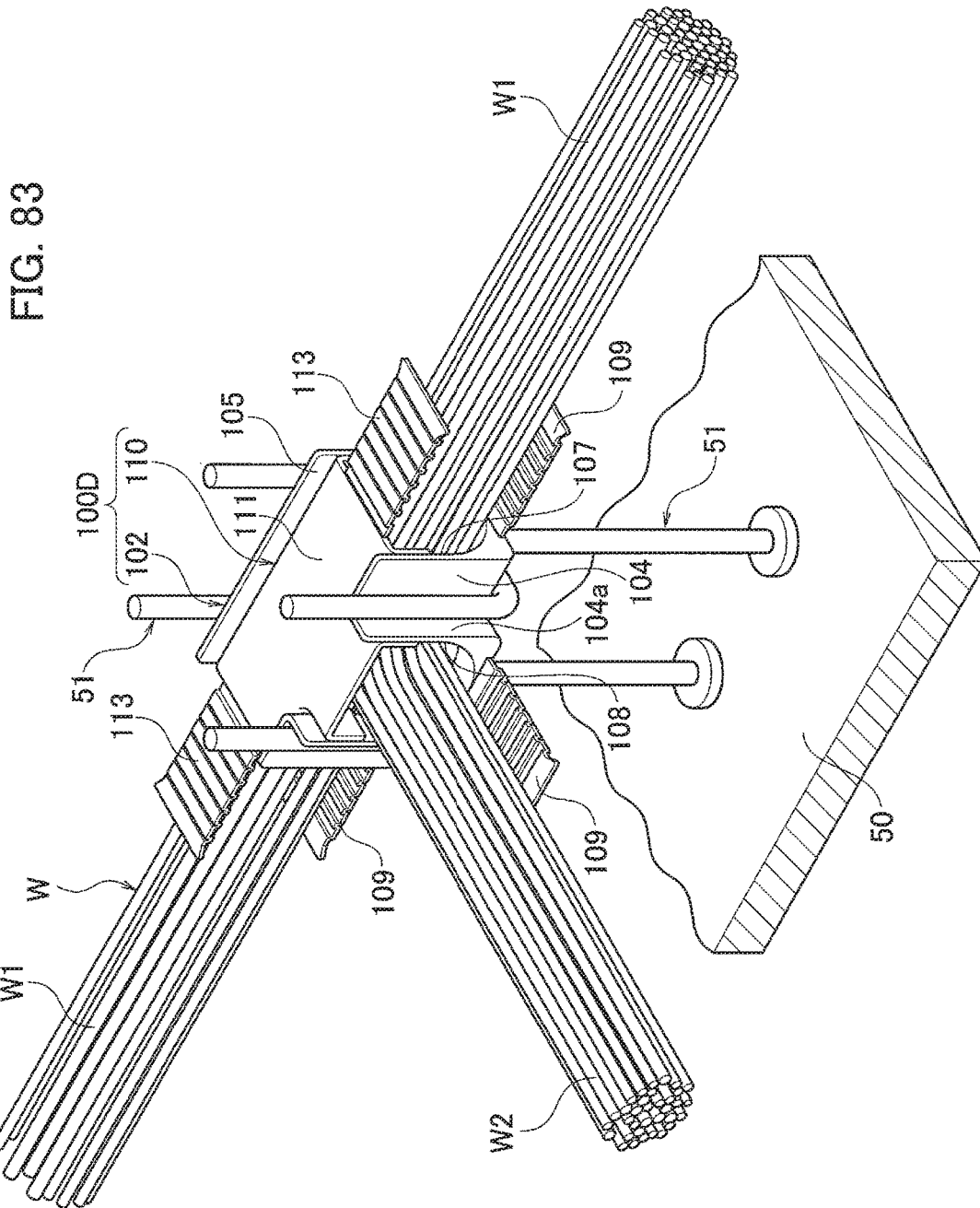
FIG. 79

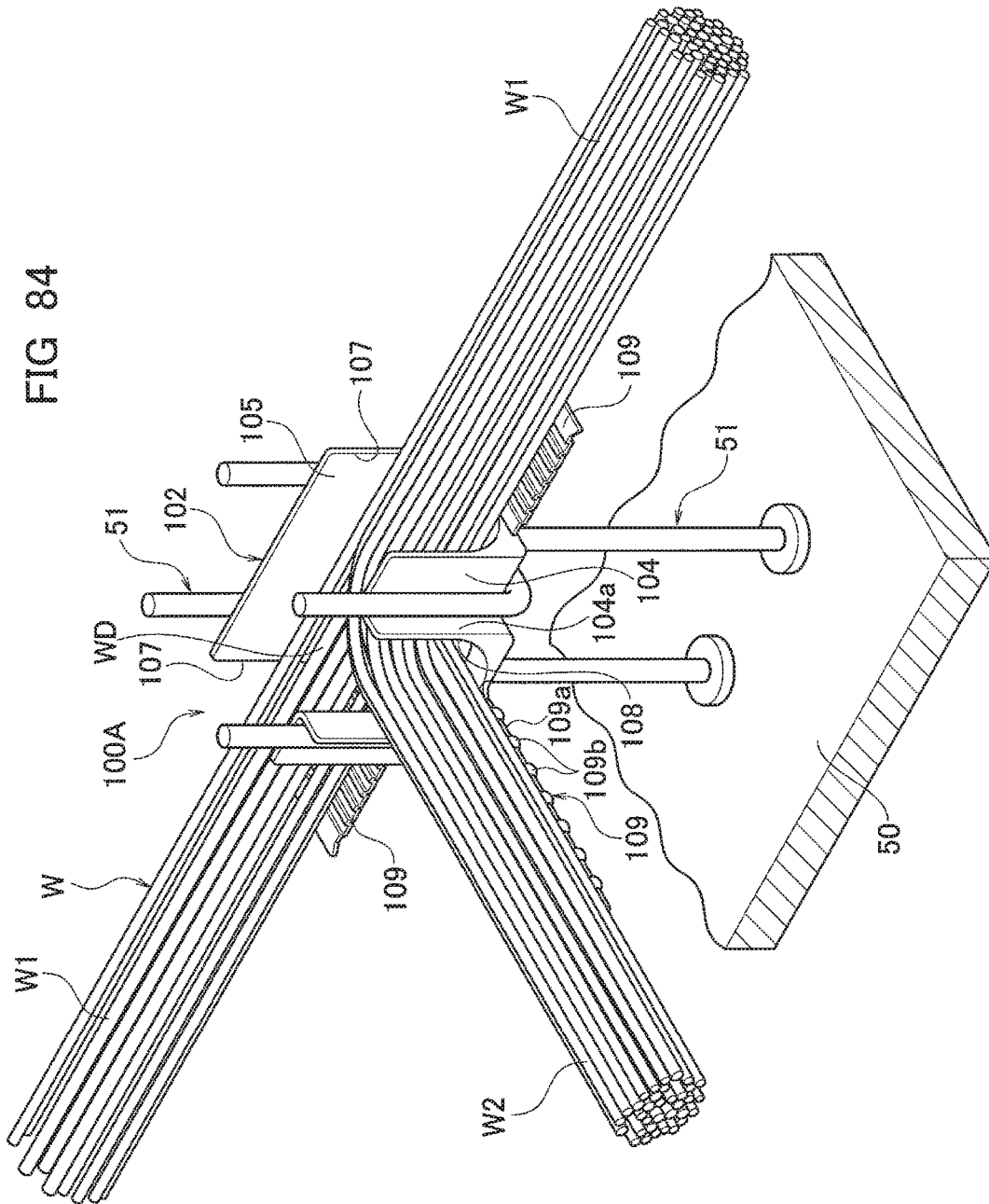


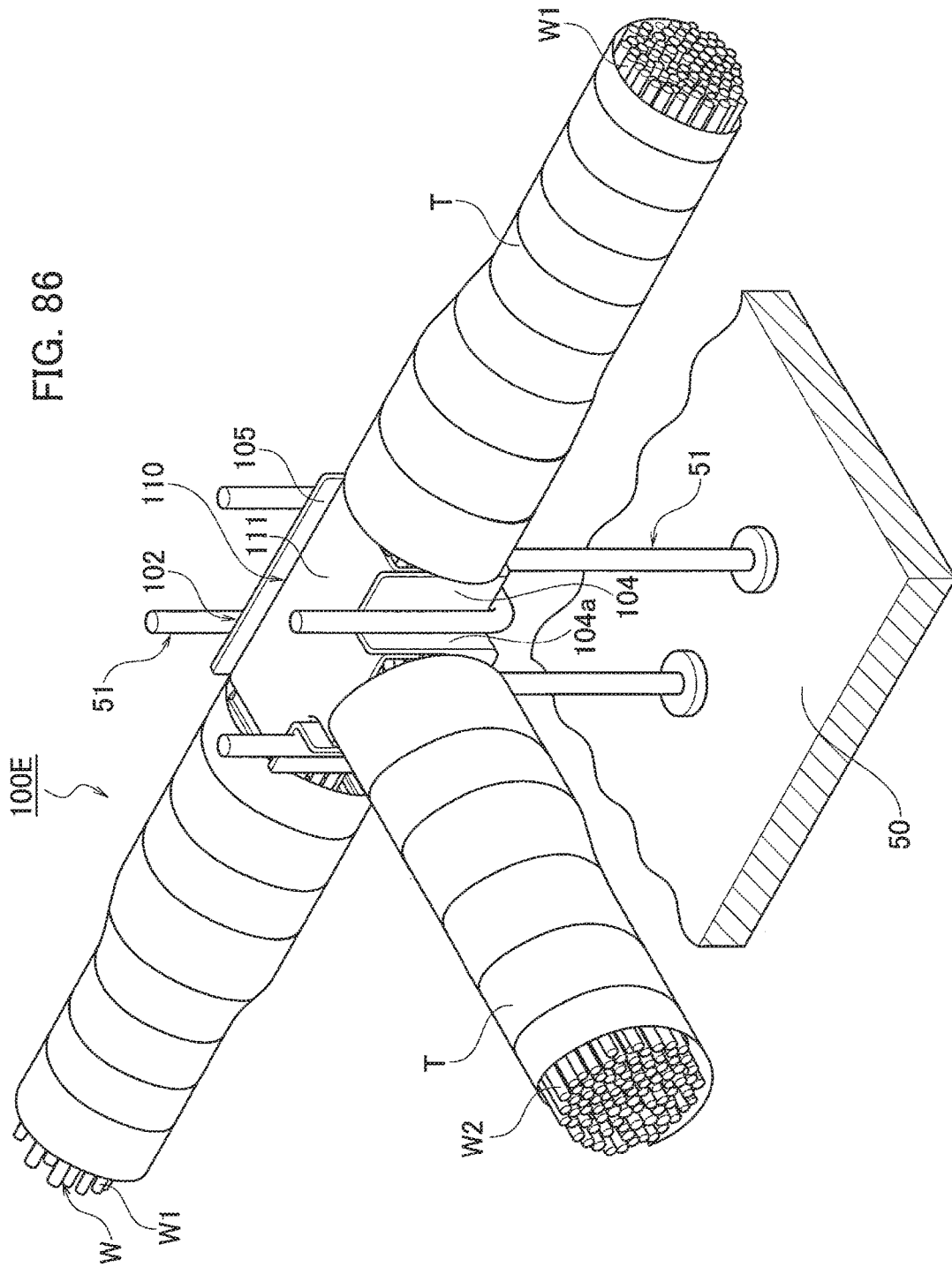












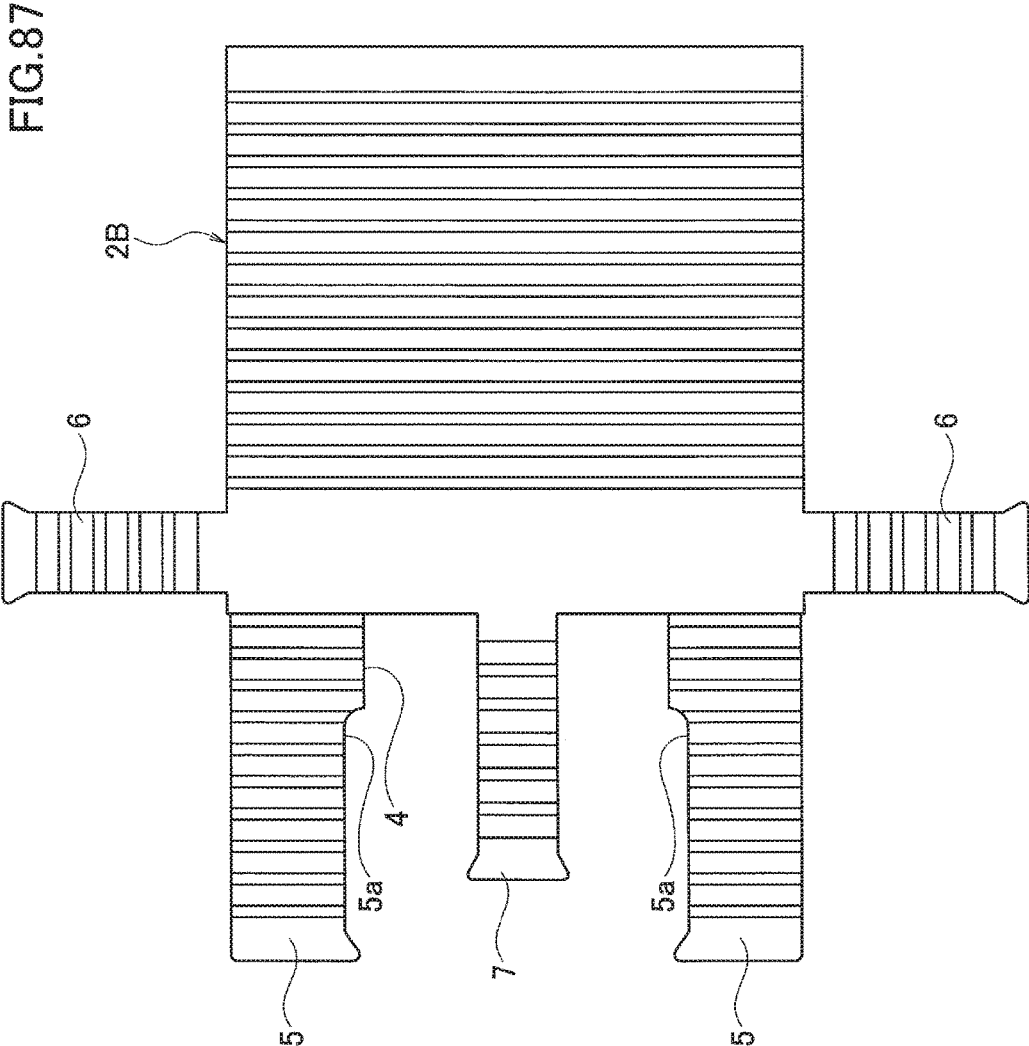
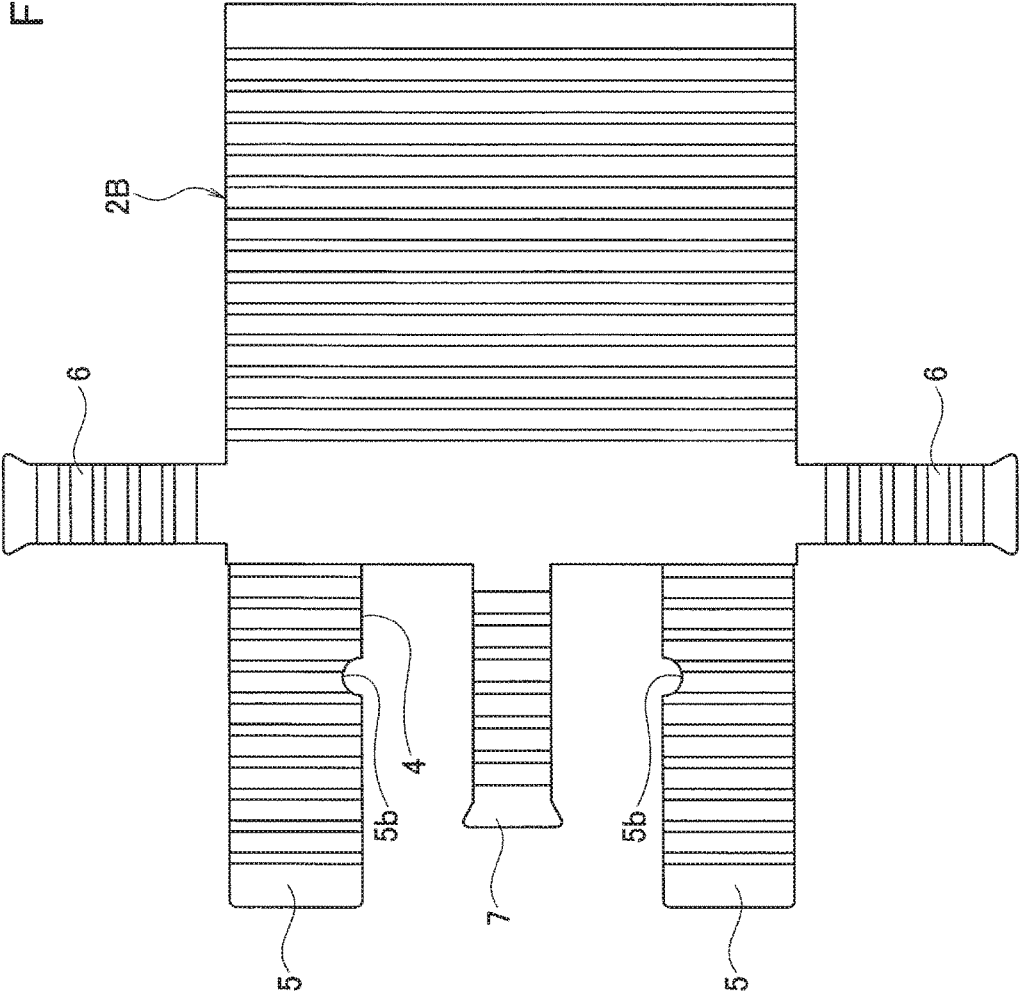
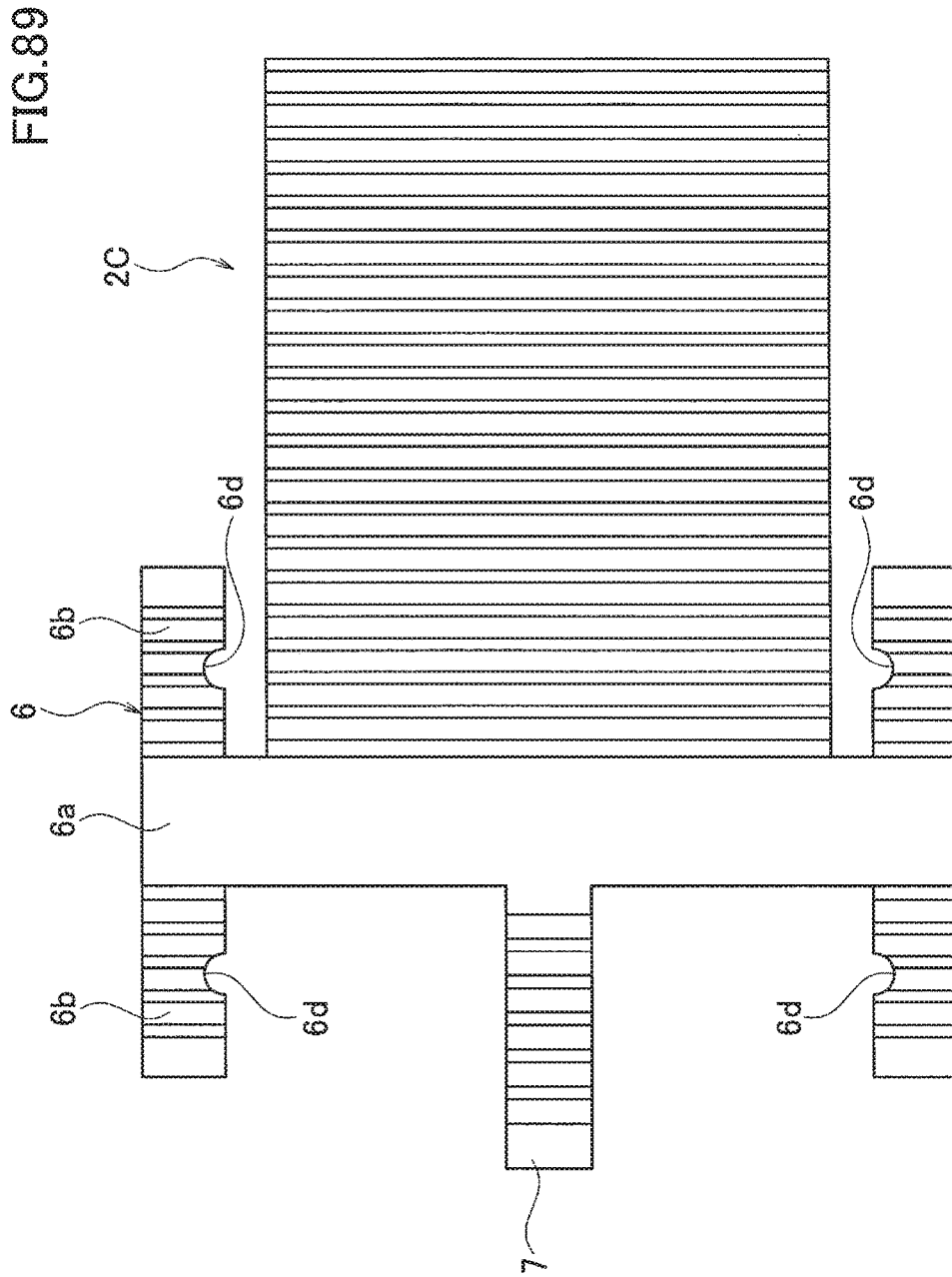


FIG.88





METHOD OF MANUFACTURING BRANCH PROTECTOR AND METHOD OF MANUFACTURING WIRE HARNESS

CROSS REFERENCE TO RELATED APPLICATION

This application is based upon and claims the benefit of priority from the prior Japanese Patent Application No. 2017-133568, filed on Jul. 7, 2017, the entire contents of which are incorporated herein by reference.

BACKGROUND OF THE INVENTION

The present invention relates to a method of manufacturing a branch protector that protects a wire branch portion, and a method of manufacturing a wire harness.

A branch protector disclosed in Japanese Patent Publication No. 5217873 is proposed as a related branch protector. As illustrated in FIGS. 1 and 2, this branch protector **200** has a branch protector main body **201** having a wire accommodating chamber **201a** and a cover **210** attached to the branch protector main body **201**.

The wire accommodating chamber **201a** is surrounded by a bottom wall **202** and a pair of side walls **203**, and the wire accommodating chamber **201a** whose upper surface is opened is formed. Two wire draw-out openings **204** are provided at both ends of the pair of side walls **203**. A tape winding tongue piece **206** is provided to extend at both ends of the pair of side walls **203**. One wire draw-out opening **205** is provided at a center position of one of the side walls **203** (a position between both ends of the side wall **203**). A branch line fixing plate **207** is provided to extend at a position where the wire draw-out opening **205** of the one side wall **203** is provided.

A wire branch portion (not illustrated) of a wire *W* is accommodated in the wire accommodating chamber **201a**. One branch line *W2* is branched from a trunk line *W1* at the wire branch portion. As a result, the two trunk lines *W1* and the one branch line *W2* extend in different directions from the wire branch portion. The two trunk lines *W1* are drawn out to the outside through the wire draw-out opening **204** at both the ends, respectively. The one branch line *W2* is drawn out to the outside through the wire draw-out opening **205** at the center position.

The cover **210** closes the upper surface of the wire accommodating chamber **201a** in the state of being mounted to the branch protector main body **201**. In addition, the wire branch portion is accommodated in the wire accommodating chamber **201a** covered with the branch protector main body **201** and the cover **210**, thereby protecting the wire branch portion.

The related branch protector **200** is manufactured in a state where the branch protector main body **201** is placed on a jig base. Specifically, the branch protector main body **201** is placed on the jig base in a positioned state. Next, the wire branch portion is accommodated in the wire accommodating chamber **201a**. Next, the upper surface of the wire accommodating chamber **201a** is closed by the cover **210**. Next, a tape *T* is wound collectively around the tape winding tongue piece **206** and the trunk line *W1*. Further, the branch line *W2* is fixed to the branch line fixing plate **207** by a fastening band **208**. The manufacture is completed with this process.

The related branch protector is exemplified in Japanese Patent Publication No. 5217873.

SUMMARY OF THE INVENTION

In a method of manufacturing the related branch protector **200**, however, it is necessary to lift the branch protector main

body **201** above the jig base during winding work of the tape *T*. Further, it is also necessary to lift a part of the branch protector main body **201** above the jig base during attachment work of the fastening band **208**. Therefore, there is a problem that the assembling workability of the branch protector **200** is poor.

The invention has been made to solve the above-described problems, and it is possible to provide a method of manufacturing a branch protector and a method of manufacturing a wire harness with favorable assembling workability according to the invention.

According to a technical aspect of the invention, the method of manufacturing a branch protector includes a component setting step of supporting a main component of the branch protector in a floating state from a jig base on a jig pin erected on the jig base, and an assembling step of assembling a wire branch portion to the main component.

According to the invention, the main component of the branch protector is supported in the floating state on the jig base, and a lower space of the main component of the branch protector can also be used as an assembling work space, and thus, the assembling workability is favorable.

BRIEF DESCRIPTION OF THE DRAWING

FIG. 1 is an exploded perspective view of a related branch protector;

FIG. 2 is a perspective view of an assembled state of the related branch protector;

FIG. 3 illustrates a first embodiment of the invention and is a perspective view from a front surface of a protector sheet in a developed state;

FIG. 4 illustrates the first embodiment of the invention and is a perspective view from a rear surface of the protector sheet in the developed state;

FIG. 5 illustrates the first embodiment of the invention and is a perspective view in which a wire branch portion is placed on the protector sheet;

FIG. 6A is a perspective view of a state where the protector sheet is wound around the wire branch portion in the first embodiment of the invention;

FIG. 6B is a front view of the state where the protector sheet is wound around the wire branch portion in the first embodiment of the invention;

FIG. 7A is a perspective view of a state where a restraint tape is wound around the protector sheet and a trunk line and the protector sheet and a branch line in the first embodiment of the invention;

FIG. 7B is a front view of the state where the restraint tape is wound around the protector sheet and the trunk line and the protector sheet and the branch line in the first embodiment of the invention;

FIG. 8 illustrates a second embodiment of the invention and is a perspective view from a front surface of a protector sheet in a developed state;

FIG. 9 illustrates the second embodiment of the invention and is a perspective view from a front surface of a protector sheet in a wound state;

FIG. 10 illustrates a third embodiment of the invention and is a perspective view from a front surface of a protector sheet in a developed state;

FIG. 11 illustrates the third embodiment of the invention and is a perspective view from a front surface of a protector sheet in a wound state;

FIG. 12 illustrates a fourth embodiment of the invention and is a perspective view from a front surface of a protector sheet in a developed state;

3

FIG. 13 illustrates the fourth embodiment of the invention and is a perspective view from a front surface of a protector sheet in a wound state;

FIG. 14 illustrates a fifth embodiment of the invention and is a perspective view from a front surface of a protector sheet in a developed state;

FIG. 15 illustrates the fifth embodiment of the invention and is a perspective view from a front surface of a protector sheet in a wound state;

FIG. 16 illustrates a sixth embodiment of the invention and is a perspective view from a front surface of a protector sheet in a developed state;

FIG. 17 illustrates the sixth embodiment of the invention and is a perspective view from a front surface of a protector sheet in a wound state;

FIG. 18 illustrates a seventh embodiment of the invention and is a perspective view from a front surface of a protector sheet in a developed state;

FIG. 19 illustrates the seventh embodiment of the invention and is a perspective view from a front surface of a protector sheet in a wound state;

FIG. 20 illustrates an eighth embodiment of the invention and is a perspective view of a protector sheet and a reinforcing protector sheet both in a developed state;

FIG. 21A is a perspective view of a state where the protector sheet is wound around a wire branch portion in the eighth embodiment of the invention;

FIG. 21B is a front view of the state where the protector sheet is wound around the wire branch portion in the eighth embodiment of the invention;

FIG. 22A is a perspective view of a state where the reinforcing protector sheet is wound above the protector sheet in the eighth embodiment of the invention;

FIG. 22B is a front view of the state where the reinforcing protector sheet is wound above the protector sheet in the eighth embodiment of the invention;

FIG. 23A is a perspective view of a state where a restraint tape is wound around the protector sheet, the reinforcing protector sheet, and a trunk line, and the protector sheet, the reinforcing protector sheet, and a branch line in the eighth embodiment of the invention;

FIG. 23B is a front view of the state where a restraint tape is wound around the protector sheet, the reinforcing protector sheet, and the trunk line, and the protector sheet, the reinforcing protector sheet, and the branch line in the eighth embodiment of the invention;

FIG. 24 illustrates a ninth embodiment of the invention and is a perspective view of a protector sheet and a reinforcing protector sheet both in a developed state;

FIG. 25 illustrates the ninth embodiment of the invention and is a perspective view of the protector sheet in a wound state and the reinforcing protector sheet;

FIG. 26 illustrates the ninth embodiment of the invention and is a perspective view of a state where the reinforcing protector sheet is wound above the protector sheet in the wound state;

FIG. 27 illustrates a tenth embodiment of the invention and is a perspective view of a protector sheet in a developed state and a reinforcing protector plate;

FIG. 28 illustrates the tenth embodiment of the invention and is a perspective view of a state where the reinforcing protector plate is placed on the protector sheet in the developed state;

FIG. 29 illustrates the tenth embodiment of the invention and is a perspective view of a state where the protector sheet is wound above the reinforcing protector plate;

4

FIG. 30 illustrates an eleventh embodiment of the invention and is a perspective view of a protector sheet in a developed state and a reinforcing protector plate;

FIG. 31 illustrates the eleventh embodiment of the invention and is a perspective view of a state where the reinforcing protector plate is placed on the protector sheet in the developed state;

FIG. 32 illustrates the eleventh embodiment of the invention and is a perspective view of a state where the protector sheet is wound above the reinforcing protector plate;

FIG. 33 illustrates a twelfth embodiment of the invention and is a perspective view of a protector plate and a reinforcing protector sheet in a developed state;

FIG. 34 illustrates the twelfth embodiment of the invention and is a perspective view of a state where the reinforcing protector sheet is wound above the protector plate;

FIG. 35 illustrates a thirteenth embodiment of the invention and is an exploded perspective view of a branch protector;

FIG. 36 illustrates the thirteenth embodiment of the invention and is a perspective view illustrating a state where a cover is arranged inside a branch protector main body;

FIG. 37 illustrates the thirteenth embodiment of the invention and is a perspective view of the state where the cover is arranged inside the branch protector main body as seen from a bottom surface;

FIG. 38 illustrates the thirteenth embodiment of the invention and is a perspective view in which a branch portion of a wire is accommodated inside the branch protector main body;

FIG. 39 illustrates the thirteenth embodiment of the invention and is a perspective view illustrating a state where the cover is dropped onto the branch portion of the wire accommodated in the branch protector main body;

FIG. 40 illustrates the thirteenth embodiment of the invention and is a perspective view illustrating a state where a tape is wound around a trunk line and a branch line drawn out from the branch protector;

FIG. 41 illustrates the thirteenth embodiment of the invention and is a perspective view illustrating a fact that it is possible to visually confirm that the cover is properly fitted;

FIG. 42 illustrates the thirteenth embodiment of the invention and is a cross-sectional view of the main part of the branch protector;

FIG. 43 illustrates a fourteenth embodiment of the invention and is an exploded perspective view of a branch protector;

FIG. 44 illustrates the fourteenth embodiment of the invention and is a cross-sectional view of the main part of the branch protector;

FIG. 45 illustrates a fifteenth embodiment of the invention and is an exploded perspective view of a branch protector;

FIG. 46 illustrates the fifteenth embodiment of the invention and is a perspective view illustrating a state where a cover is arranged inside a branch protector main body;

FIG. 47 illustrates the fifteenth embodiment of the invention and is a perspective view illustrating a case of being used for a branch portion where wires extend in three directions;

FIG. 48 illustrates a sixteenth embodiment of the invention and is an exploded perspective view of a branch protector;

FIG. 49 illustrates the sixteenth embodiment of the invention and is a perspective view illustrating a state where a cover is arranged inside a branch protector main body;

FIG. 50 illustrates a seventeenth embodiment of the invention and is an exploded perspective view of a branch protector;

FIG. 51 illustrates the seventeenth embodiment of the invention and is a perspective view illustrating a state where a cover is arranged inside a branch protector main body;

FIG. 52A is a perspective view of a jig base and a jig pin;

FIG. 52B is a perspective view for describing assembling using the jig pin regarding the branch protector of the first embodiment;

FIG. 53 is a perspective view for describing assembling using the jig pin regarding the branch protector of the first embodiment;

FIG. 54 is a perspective view for describing assembling using the jig pin regarding the branch protector of the first embodiment;

FIG. 55 is a perspective view for describing assembling using the jig pin regarding the branch protector of the first embodiment;

FIG. 56 is a perspective view for describing assembling using the jig pin regarding the branch protector of the eighth embodiment;

FIG. 57 is a perspective view for describing assembling using the jig pin regarding the branch protector of the eighth embodiment;

FIG. 58 is a perspective view for describing assembling using the jig pin regarding the branch protector of the eighth embodiment;

FIG. 59 is a perspective view for describing assembling using the jig pin regarding the branch protector of the tenth embodiment;

FIG. 60 is a perspective view for describing assembling using the jig pin regarding the branch protector of the tenth embodiment;

FIG. 61 is a perspective view for describing assembling using the jig pin regarding the branch protector of the tenth embodiment;

FIG. 62 is a perspective view for describing assembling using the jig pin regarding the branch protector of the tenth embodiment;

FIG. 63 is a perspective view for describing assembling using the jig pin regarding the branch protector of the ninth embodiment;

FIG. 64 is a perspective view for describing assembling using jig pins of the branch protector of the ninth embodiment;

FIG. 65 is a perspective view for describing assembling using jig pins of the branch protector of the ninth embodiment;

FIG. 66 is a perspective view for describing assembling using jig pins of the branch protector of the ninth embodiment;

FIG. 67 is a perspective view for describing assembling using jig pins of the branch protector of the ninth embodiment;

FIG. 68 is a perspective view for describing assembling using jig pins of the branch protector of the ninth embodiment;

FIG. 69 is a perspective view for describing assembling using jig pins of the branch protector of the ninth embodiment;

FIG. 70 is a perspective view for describing assembling using jig pins of the branch protector of the eleventh embodiment;

FIG. 71 is a perspective view for describing assembling using jig pins of the branch protector of the eleventh embodiment;

FIG. 72 is a perspective view for describing assembling using jig pins of the branch protector of the eleventh embodiment;

FIG. 73 is a perspective view for describing assembling using jig pins of the branch protector of the eleventh embodiment;

FIG. 74 is a perspective view for describing assembling using jig pins of the branch protector of the twelfth embodiment;

FIG. 75 is a perspective view for describing assembling using jig pins of the branch protector of the twelfth embodiment;

FIG. 76 is a perspective view for describing assembling using jig pins of the branch protector of the twelfth embodiment;

FIG. 77 is a perspective view for describing assembling using jig pins of the branch protector of the twelfth embodiment;

FIG. 78 is a perspective view for describing assembling using jig pins of the branch protector of the twelfth embodiment;

FIG. 79 is a perspective view for describing assembling using jig pins of the branch protector of the thirteenth embodiment;

FIG. 80 is a perspective view for describing assembling using jig pins of the branch protector of the thirteenth embodiment;

FIG. 81 is a perspective view for describing assembling using jig pins of the branch protector of the thirteenth embodiment;

FIG. 82 is a perspective view for describing assembling using jig pins of the branch protector of the thirteenth embodiment;

FIG. 83 is a perspective view for describing assembling using jig pins of the branch protector of the sixteenth embodiment;

FIG. 84 is a perspective view for describing assembling using jig pins of the branch protector of the seventeenth embodiment;

FIG. 85 is a perspective view for describing assembling using jig pins of the branch protector of the seventeenth embodiment;

FIG. 86 is a perspective view for describing assembling using jig pins of the branch protector of the seventeenth embodiment;

FIG. 87 is a developed view of a first modification of a protector sheet 2B;

FIG. 88 is a developed view of the first modification of the protector sheet 2B; and

FIG. 89 is a developed view of a first modification of a protector sheet 2C.

DESCRIPTION OF THE PREFERRED EMBODIMENTS

Embodiments of the invention will be described below with reference to the drawings.

First Embodiment

FIGS. 3 to 7B illustrate a first embodiment of the invention. A wire harness includes a wire (wire bundle) W that are routed along a predetermined routing path and has a wire branch portion WD and a branch protector 1A that protects the wire branch portion WD. As illustrated in FIG. 5, one branch line W2 is branched from a trunk line W1 at the wire branch portion WD. That is, the wire branch portion WD has

7

three branches in which two trunk lines W1 and one branch line W2 extend in different directions. The branch protector 1A that protects the three-branch wire branch portion WD will be described.

The branch protector 1A (illustrated in FIGS. 7A and 7B) includes a protector sheet 2A mounted on the outer circumference of the wire branch portion WD and a restraint tape T wound around the protector sheet 2A, the trunk line W1, and the branch line W2.

As illustrated in FIG. 3, the protector sheet 2A is a flexible sheet having a flat shape before being mounted to the wire branch portion WD.

The protector sheet 2A includes a pair of strip-shaped sheet portions 5 arranged with an interval by a cut-out portion 4, a tape winding protruding portion 6 for the two trunk lines W1, and a tape winding protruding portion 7 for one branch line.

The protector sheet 2A has a component placement portion 2a extending along a trunk line routing direction M. The component placement portion 2a is formed in a flat shape. The protector sheet 2A other than the component placement portion 2a is formed in a bellows-shape in which a recess and a protrusion are alternately repeated toward an orthogonal direction N (a winding distal end direction) of the trunk line routing direction M.

The protector sheet 2A is wound around an outer circumference of the wire branch portion WD except for a part where the branch line W2 is drawn out. The pair of strip-shaped sheet portions 5 is wound around parts of the trunk lines W1 on both outer sides of the part where the branch line W2 is drawn out. Winding distal ends of the respective strip-shaped sheet portions 5 are wound at the outer side of the protector sheet 2A to overlap each other. Trunk line draw-out openings 8 are formed at both ends of the protector sheet 2A in the trunk line routing direction M in accordance with a winding shape of the protector sheet 2A. The trunk lines W1 of the wire branch portion WD are drawn out from the respective trunk line draw-out openings 8.

A branch line draw-out opening 9 is formed by the cut-out portion 4 in the protector sheet 2A. The branch line W2 of the wire branch portion WD is drawn out from the branch line draw-out opening 9.

A clip mounting portion 2b is provided on a rear surface of the component placement portion 2a of the protector sheet 2A. A clip 10, which is a fixing portion for a vehicle body, is attached to the clip mounting portion 2b.

The respective tape winding protruding portions 6 for the trunk line W1 are provided to extend from both the ends of the protector sheet 2A in the trunk line routing direction M. The respective tape winding protruding portions 6 for the trunk line W1 protrude in directions of routing the trunk lines W1 drawn out from the trunk line draw-out openings 8, respectively, in the state of mounting the branch protector 1A.

The tape winding protruding portion 7 for the branch line W2 is provided to extend from a side end of the component placement portion 2a of the protector sheet 2A in the orthogonal direction N of the trunk line routing direction M. The tape winding protruding portion 7 for the branch line W2 is positioned on a side opposite to the cut-out portion 4. The tape winding protruding portion 7 for the branch line W2 protrudes in a direction of routing the branch line W2 drawn out from the branch line draw-out opening 9 in the state of mounting the branch protector 1A.

Each of the tape winding protruding portions 6 and 7 has a sheet shape continuous to the protector sheet 2A. Each of the tape winding protruding portions 6 and 7 is formed in a

8

bellows-shape in which a recess and a protrusion are alternately repeated along a protruding direction.

Assembling work of the branch protector 1A will be described. As illustrated in FIG. 3, the protector sheet 2A in a developed state is arranged at an assembling work position (for example, a position held by a jig pin erected on a jig base). Next, the wire branch portion WD is placed on the protector sheet 2A as illustrated in FIG. 5.

Specifically, the trunk lines W1 of the wire branch portion WD are placed on the component placement portion 2a and the two tape winding protruding portions 6 for the trunk lines W1, and the branch line W2 of the wire branch portion WD is placed on the tape winding protruding portion 7 for the branch line W2.

Next, the protector sheet 2A is wound around the outer circumference of the wire branch portion WD with no gap as illustrated in FIG. 6. The winding distal ends of the pair of strip-shaped sheet portions 5 of the protector sheet 2A are wound at the outer side of the protector sheet 2A to overlap each other.

Next, the restraint tape T is wound around the protector sheet 2A and the respective trunk lines W1 and the protector sheet 2A and the branch line W2 with no gap as illustrated in FIGS. 7A and 7B.

Specifically, regarding each of the trunk lines W1, the restraint tape T is wound around the outer circumference of the protector sheet 2A (each part of the strip-shaped sheet portions 5) in a range where each of the tape winding protruding portions 6 is not present, wound collectively around the outer circumferences of the tape winding protruding portion 6 and the trunk line W1 in a range where the tape winding protruding portion 6 is present, and wound around the outer circumference of the trunk line W1 with no gap at a part on a side closer to the distal end than the tape winding protruding portion 6, using both end positions of the cut-out portion 4 of the protector sheet 2A as winding start points. As a result, the respective trunk line draw-out openings 8 are completely shielded by the restraint tape T.

Regarding the branch line W2, the restraint tape T is wound collectively around the outer circumferences of the tape winding protruding portion 7 and the branch line W2 in a range where the tape winding protruding portion 7 is present and wound around the outer circumference of the branch line W2 with no gap at a part in front of a distal end of the tape winding protruding portion 7, using a root position of the tape winding protruding portion 7 as a winding start point. The assembling work of the branch protector 1A is completed in this manner.

The wire harness is assembled as components other than the branch protector 1A are mounted to the trunk line W1 and the branch line W2 before, after, or concurrently with the assembling work of the branch protector 1A.

As described above, the branch protector 1A has the cut-out portion 4 from which the branch line W2 of the wire branch portion WD is drawn out, and further, has the flexible protector sheet 2A wound around the trunk line W1 of the wire branch portion WD and from which the trunk lines W1 of the wire branch portion WD are drawn out and the tape winding protruding portions 6 provided to extend from both the ends of the protector sheet 2A, respectively, and protrude in the routing directions of the drawn-out trunk lines W1.

Therefore, the wire branch portion WD can be protected regardless of a size of the wire branch portion WD since the wire branch portion WD is protected by winding the protector sheet 2A around the wire branch portion WD. Moreover, a useless space is not formed inside the protector sheet 2A since the protector sheet 2A covers an outer surface of

the wire branch portion WD. As described above, it is possible to protect the wire branch portion WD regardless of the size of the wire branch portion WD, and moreover, it is possible to make the size compact as much as possible.

In addition, the protector sheet 2A has the tape winding protruding portion 6 at a part where the trunk line W1 is drawn out. Therefore, the trunk line W1 and the branch protector 1A can be firmly fixed by winding the restraint tape T around the trunk line W1 and the tape winding protruding portion 6 collectively. As a result, it is possible to reliably prevent the branch protector 1A from being detached from the trunk line W1 due to a pulling force acting on the trunk line W1, or from causing a relative positional deviation although the branch protector 1A is not detached.

The branch protector 1A includes the two trunk line draw-out openings 8 formed by the winding shapes of both the ends of the protector sheet 2A and from which the trunk lines W1 are drawn out, respectively, and the branch line draw-out opening 9 formed by the cut-out portion 4 of the protector sheet 2A and from which the branch line W2 is drawn out.

Therefore, it is unnecessary to form a unique shape such as a cut-out for to form the two trunk line draw-out openings 8 on the protector sheet 2A, and the branch protector 1A can be obtained with a simple sheet shape.

The protector sheet 2A has the pair of strip-shaped sheet portions 5 with the cut-out portion 4 therebetween, and is wound around the entire circumference of the trunk lines W1 on both outer sides of the branch line W2 of the wire branch portion WD.

Therefore, it is possible to protect the entire part of the wire branch portion WD by the protector sheet 2A except for the part where the branch line W2 is drawn out.

The winding distal ends of the respective strip-shaped sheet portions 5 are wound around the protector sheet 2A to overlap each other. Therefore, it is possible to protect the entire circumference of the trunk line W1 simply by winding the protector sheet 2A around the outer circumference of the trunk line W1. With the overlapping winding, the strength of the branch protector 1A is increased and a protection function is improved.

The protector sheet 2A has the tape winding protruding portion 7 that protrudes in the routing direction of the drawn-out branch line W2. Therefore, the branch line W2 and the branch protector 1A can be firmly fixed by winding the restraint tape T around the branch line W2 and the tape winding protruding portion 7 collectively. As a result, it is possible to reliably prevent the branch protector 1A from being detached from the branch line W2 due to a pulling force acting on the branch line W2, or from causing a relative positional deviation although the branch protector 1A is not detached.

The protector sheet 2A is formed in the bellows-shape except for the component placement portion 2a. Therefore, the winding workability is favorable since the protector sheet 2A can be easily wound around the trunk line W1.

Each of the tape winding protruding portions 6 and 7 for the trunk line W1 and the branch line W2 is formed like a sheet in the bellows-shape. Therefore, the trunk line W1 and the branch line W2 drawn out from the branch protector 1A can be easily bent and deformed in an up-down direction UD in the routing directions of the trunk line W1 and the branch line W2, and thus, the routing workability is favorable. Further, the degree of freedom in the routing direction is also high.

The protector sheet 2A is provided with the clip 10. Therefore, the branch protector 1A can be easily fixed to the vehicle body using the clip 10.

Second Embodiment

FIGS. 8 and 9 illustrate a second embodiment of the invention. As compared with the first embodiment, a position of the cut-out portion 4 of a protector sheet 2B and positions of the pair of strip-shaped sheet portions 5 in a branch protector of the second embodiment are different from those of the first embodiment. That is, the cut-out portion 4 is formed on a side opposite to that of the first embodiment in the component placement portion 2a, and the pair of strip-shaped sheet portions 5 is provided on a side opposite to that of the first embodiment. As a result, the tape winding protruding portion 7 for a branch line is provided to extend from the component placement portion 2a in the same direction similarly to the pair of strip-shaped sheet portions 5, and is arranged using the cut-out portion 4. That is, the tape winding protruding portion 7 for the branch line is positioned between the pair of strip-shaped sheet portions 5.

Since other configurations are the same as those of the first embodiment, the same constituent parts in the drawings will be denoted by the same reference numerals, and the description thereof will be omitted.

Even in the second embodiment, a wire branch portion can be protected regardless of a size of the wire branch portion (not illustrated), and moreover, it is possible to make the size compact as much as possible, which is similar to the first embodiment.

In addition, the tape winding protruding portion 6 is provided at a part where a trunk line (not illustrated) is drawn out to the protector sheet 2B, and thus, the trunk line and the branch protector can be firmly fixed by winding the restraint tape T around the trunk line and the tape winding protruding portion 6 collectively.

The tape winding protruding portion 7 for the branch line is provided to extend from the component placement portion 2a in the same direction similarly to the pair of strip-shaped sheet portions 5, and is arranged using the cut-out portion 4. Therefore, a size in the orthogonal direction N (a width direction) of the trunk line routing direction M of the protector sheet 2B in a developed state is shortened as compared with the first embodiment.

Third Embodiment

FIGS. 10 and 11 illustrate a third embodiment of the invention. As compared with the second embodiment, a branch protector of the third embodiment has a different configuration of the tape winding protruding portion 6 for a trunk line (not illustrated) of a protector sheet 2C. That is, the tape winding protruding portion 6 for the trunk line has a linear protrusion 6a extending along a routing direction of the drawn-out trunk line and a pair of winding protrusions 6b extending in an orthogonal direction from a distal end of the linear protrusion 6a. The linear protrusion 6a is formed at a flat portion to be continuous to the component placement portion 2a. The pair of winding protrusions 6b is formed in a bellows-shape in which a recess and a protrusion are alternately repeated along the orthogonal direction N (a winding distal end direction) of the trunk line routing direction M.

Since other configurations are the same as those of the first embodiment, the same constituent parts in the drawings

11

will be denoted by the same reference numerals, and the description thereof will be omitted.

Even in the third embodiment, a wire branch portion can be protected regardless of a size of the wire branch portion (not illustrated), and moreover, it is possible to make the size compact as much as possible, which is similar to the first embodiment.

In addition, the tape winding protruding portion 6 is provided at a part where the trunk line is drawn out to the protector sheet 2C, and thus, the trunk line and the branch protector can be firmly fixed by winding a restraint tape (not illustrated) around the trunk line and the tape winding protruding portion 6 collectively.

In particular, the tape winding protruding portion 6 for the trunk line has the linear protrusion 6a that abuts on a part of an outer circumference of the trunk line and the pair of winding protrusions 6b that is wound around the outer circumference of the trunk line. Therefore, the fixing of trunk line and branch protector, obtained by winding the restraint tape around the trunk line and the tape winding protruding portion 6 collectively, is further strengthened.

Fourth Embodiment

FIGS. 12 and 13 illustrate a fourth embodiment of the invention. A branch protector of the fourth embodiment protects a four-branch wire branch portion. That is, the wire branch portion in which two branch lines are branched from a trunk line in directions different from each other by 180 degrees is protected.

As illustrated in FIG. 12, the branch protector before being mounted to the wire branch portion is a single flexible sheet that includes a protector sheet 2D and four tape winding protruding portions 6 and 7 extending from the protector sheet 2D.

The protector sheet 2D has the pair of strip-shaped sheet portions 5 divided into two by the cut-out portion 4. The protector sheet 2D has the component placement portion 2a which is a flat portion. The tape winding protruding portions 6 for a trunk line (not illustrated) are provided to extend, respectively, from both ends of the component placement portion 2a of the protector sheet 2D in the trunk line routing direction M. The tape winding protruding portions 7 for a branch line (not illustrated) are provided to extend, respectively, from both side ends of the component placement portion 2a in the orthogonal direction N of the trunk line routing direction M of the component placement portion.

Configurations of the respective tape winding protruding portions 6 and 7 are the same as those of the first embodiment.

Even in the fourth embodiment, a wire branch portion can be protected regardless of a size of the wire branch portion (not illustrated), and moreover, it is possible to make the size compact as much as possible, which is similar to the first embodiment.

In addition, the tape winding protruding portion 6 is provided at a part where the trunk line is drawn out to the protector sheet 2D, and thus, the trunk line and the branch protector can be firmly fixed by winding a restraint tape (not illustrated) around the trunk line and the tape winding protruding portion 6 collectively.

Fifth Embodiment

FIGS. 14 and 15 illustrate a fifth embodiment of the invention. As compared with the first embodiment, a branch protector of the fifth embodiment has a different configura-

12

tion of the tape winding protruding portion 7 for a branch line of a protector sheet 2E. That is, the tape winding protruding portion 7 for the branch line is a flexible rod 7a. Spherical protrusions 7b are provided to protrude from the flexible rod 7a with intervals

Since other configurations are the same as those of the first embodiment, the same constituent parts in the drawings will be denoted by the same reference numerals, and the description thereof will be omitted.

Even in the fifth embodiment, a wire branch portion can be protected regardless of a size of the wire branch portion (not illustrated), and moreover, it is possible to make the size compact as much as possible, which is similar to the first embodiment.

In addition, the protector sheet 2E is provided with the tape winding protruding portion 6 at a part where a trunk line (not illustrated) is drawn out, and thus, the trunk line and the branch protector can be firmly fixed by winding a restraint tape (not illustrated) around the trunk line and the tape winding protruding portion 6 collectively.

The tape winding protruding portion 7 for the branch line is the flexible rod 7a, and thus, can be easily bent and deformed not only in the up-down direction UD but also in a left-right direction LR. Therefore, it is possible to three-dimensionally change a direction of routing the branch line drawn out from the branch line draw-out opening 9, and further, the assembling workability is more favorable and the degree of freedom in routing is also higher as compared with the first to fourth embodiments.

The tape winding protruding portion 7 for the branch line has the spherical protrusions 7b at intervals. Therefore, the restraint tape (not illustrated) is wound so as to eat into the spherical protrusion 7b, and thus, the branch line and the branch protector can be firmly fixed.

Sixth Embodiment

FIGS. 16 and 17 illustrate a sixth embodiment of the invention. As compared with the second embodiment, a branch protector of the sixth embodiment has a different configuration of the tape winding protruding portion 7 for a branch line (not illustrated) of a protector sheet 2F. That is, the tape winding protruding portion 7 for the branch line is the flexible rod 7a, which is similar to the fifth embodiment. Spherical protrusions 7b are provided to protrude from the flexible rod 7a with intervals

Since other configurations are the same as those of the second embodiment, the same constituent parts in the drawings will be denoted by the same reference numerals, and the description thereof will be omitted.

Even in the sixth embodiment, it is possible to obtain the same operational effects as those of the fifth embodiment.

Seventh Embodiment

FIGS. 18 and 19 illustrate a seventh embodiment of the invention. A branch protector of the seventh embodiment protects a four-branch wire branch portion, which is similar to the fourth embodiment. As compared with the fourth embodiment, the branch protector has a different configuration of the tape winding protruding portion 7 for a branch line (not illustrated) of a protector sheet 2G. That is, the tape winding protruding portion 7 for the branch line is the flexible rod 7a, which is similar to the fifth embodiment. Spherical protrusions 7b are provided to protrude from the flexible rod 7a with intervals

Since other configurations are the same as those of the fourth embodiment, the same constituent parts in the drawings will be denoted by the same reference numerals, and the description thereof will be omitted.

Even in the seventh embodiment, it is possible to obtain the same operational effects as those of the fifth embodiment.

Embodiment with Two Branch Protector Members

An eighth embodiment to a twelfth embodiment of the invention will be described. A branch protector in the eighth to twelfth embodiments has two branch protector members, which is different from the first to seventh embodiments. At least one of the two branch protector members is a flexible protector sheet. Each embodiment will be described hereinafter.

Eighth Embodiment

FIGS. 20 to 23B illustrate the eighth embodiment of the invention. A branch protector 1H of the eighth embodiment has two branch protector members, that is, the protector sheet 2A and a reinforcing protector sheet 21.

That is, the branch protector 1H includes the protector sheet 2A, the reinforcing protector sheet 21, and the restraint tape T that is wound around the protector sheet 2A, the reinforcing protector sheet 21, and the trunk line W1, and the protector sheet 2A, the reinforcing protector sheet 21, and the branch line W2.

Since the protector sheet 2A has the same configuration as that of the first embodiment, the same constituent parts in the drawings will be denoted by the same reference numerals, and the description thereof will be omitted.

As illustrated in FIG. 20, the reinforcing protector sheet 21 is a flexible sheet having a flat shape before being mounted to the wire branch portion WD.

The reinforcing protector sheet 21 includes a pair of strip-shaped sheet portions 25 arranged at intervals by a cut-out portion 24 and two tape winding protruding portions 26 for a trunk line.

The reinforcing protector sheet 21 is provided with a rigid sheet portion 21a extending along the trunk line routing direction M. The rigid sheet portion 21a is formed in a flat shape. A part of the reinforcing protector sheet 21 other than the rigid sheet portion 21a and the tape winding protruding portions 26 are formed in a bellows-shape in which a recess and a protrusion are alternately repeated toward the orthogonal direction N (winding distal end direction) of the trunk line routing direction M.

The reinforcing protector sheet 21 is wound from an outer side of the protector sheet 2A around an outer circumference on side of an upper surface of the wire branch portion WD except for a part where the branch line W2 is drawn out.

The respective tape winding protruding portions 26 for the trunk line W1 are provided to extend from both ends of the reinforcing protector sheet 21 in the trunk line routing direction M. The respective tape winding protruding portions 26 for the trunk line W1 protrude in directions of routing the trunk lines W1 drawn out from the trunk line draw-out openings 8, respectively, in the state of mounting the branch protector 1H.

Each of the tape winding protruding portions 26 for the trunk line W1 has a sheet shape similarly to the reinforcing protector sheet 21. Each of the tape winding protruding

portions 26 is formed in a bellows-shape in which a recess and a protrusion are alternately repeated along a protruding direction.

Next, assembling work of the branch protector 1H will be described. As illustrated in FIG. 20, the protector sheet 2A in a developed state is arranged at an assembling work position (for example, on the jig pin erected on the jig base). Next, the trunk lines W1 of the wire branch portion WD are placed on the component placement portion 2a of the protector sheet 2A and the two tape winding protruding portions 6 for the trunk lines W1, and the branch line W2 of the wire branch portion WD is placed on the tape winding protruding portion 7 for the branch line W2 as illustrated in FIGS. 21A and 21B.

Next, the protector sheet 2A is wound around the outer circumference of the wire branch portion WD with no gap as illustrated in FIGS. 21A and 21B. Winding distal ends of the pair of strip-shaped sheet portions 5 of the protector sheet 2A are wound at the outer side of the protector sheet 2A to overlap each other.

Next, the reinforcing protector sheet 21 is wound on the side of the upper surface of the wire branch portion WD so as to overlap the protector sheet 2A from above as illustrated in FIGS. 22A and 22B.

Next, the restraint tape T is wound around the protector sheet 2A, the reinforcing protector sheet 21, and the respective trunk lines W1, and the protector sheet 2A, the reinforcing protector sheet 21, and the branch line W2 with no gap as illustrated in FIGS. 23A and 23B.

Specifically, regarding each of the trunk lines W1, the restraint tape T is wound around the outer circumference of the protector sheet 2A in a range where each of the tape winding protruding portions 6 and 26 are not present, wound collectively around the tape winding protruding portions 6 and 26 and the trunk line W1 in a range where the tape winding protruding portions 6 and 26 are present, and wound around an outer circumference of the trunk line W1 with no gap at a part on a side closer to the distal end than the tape winding protruding portions 6 and 26, using both end positions of the cut-out portions 4 and 24 of the protector sheet 2A and the reinforcing protector sheet 21 as winding start points. As a result, the respective trunk line draw-out openings 8 are completely shielded by the restraint tape T.

Regarding the branch line W2, the restraint tape T is wound collectively around the outer circumferences of the tape winding protruding portion 7 and the branch line W2 in a range where the tape winding protruding portion 7 is present and wound around the outer circumference of the branch line W2 with no gap at a part on a side closer to a distal end of the tape winding protruding portion 7, using a root position of the tape winding protruding portion 7 as a winding start point. The assembling work of the branch protector 1H is completed in this manner.

A wire harness is assembled by mounting components other than the branch protector 1H to the trunk line W1 and the branch line W2.

As described above, the branch protector 1H has the cut-out portion 4 from which the branch line of the wire branch portion WD is drawn out, and further, has the flexible protector sheet 2A wound around the trunk line W1 of the wire branch portion WD and from which the trunk lines W1 of the wire branch portion WD are drawn out and the tape winding protruding portions 6 provided to extend from both the ends of the protector sheet 2A, respectively, and protrude in the routing directions of the drawn-out trunk lines W1.

Therefore, the wire branch portion WD can be protected regardless of a size of the wire branch portion WD since the

15

wire branch portion WD is protected by winding the protector sheet 2A around the wire branch portion WD. Moreover, a useless space is not formed inside the protector sheet 2A since the protector sheet 2A covers an outer surface of the wire branch portion WD. As described above, it is possible to protect the wire branch portion WD regardless of the size of the wire branch portion WD, and moreover, it is possible to make the size compact as much as possible.

In addition, the protector sheet 2A has the tape winding protruding portion 6 at a part where the trunk line W1 is drawn out. Therefore, the trunk line W1 and the branch protector 1H can be firmly fixed by winding the restraint tape T around the trunk line W1 and the tape winding protruding portion 6 collectively. As a result, it is possible to reliably prevent the branch protector 1H from being detached from the trunk line W1 due to a pulling force acting on the trunk line W1, or from causing a relative positional deviation although the branch protector 1H is not detached. In particular, since the reinforcing protector sheet 21 also has the tape winding protruding portion 26 of the trunk line W1, the trunk line W1 and the branch protector 1H can be more firmly fixed as compared with the first to seventh embodiments.

The branch protector 1H includes the two trunk line draw-out openings 8 formed by the winding shapes of both the ends of the protector sheet 2A and from which the trunk lines W1 are drawn out, respectively, and the branch line draw-out opening 9 formed by the cut-out portion 4 of the protector sheet 2A and from which the branch line W2 is drawn out.

Therefore, it is unnecessary to form a unique shape such as a cut-out for to form the two trunk line draw-out openings 8 and 9 on the protector sheet 2A, and a simple sheet shape is formed. Further, the reinforcing protector sheet 21 also has the same configuration. As described above, it is possible to obtain the branch protector 1H with the two simple sheet shapes.

The protector sheet 2A has the pair of strip-shaped sheet portions 5 with the cut-out portion 4 therebetween, and the protector sheet 2A is wound around the entire circumference of the trunk lines W1 on both outer sides of the branch line of the wire branch portion WD. Therefore, it is possible to protect the entire part of the wire branch portion WD by the protector sheet 2A except for the part where the branch line W2 is drawn out. Further, the reinforcing protector sheet 21 is also wound around the wire branch portion WD from above the protector sheet 2A. That is, since the branch protector 1H protects the wire branch portion WD with the two sheets of the protector sheet 2A and the reinforcing protector sheet 21, the wire branch portion WD can be firmly protected.

The winding distal ends of the respective strip-shaped sheet portions 5 are wound around the protector sheet 2A to overlap each other. Therefore, it is possible to protect the entire circumference of the trunk line W1 simply by winding the protector sheet 2A around the outer circumference of the trunk line W1. With the overlapping winding, the strength of the branch protector 1H is increased and a protection function is improved.

The protector sheet 2A has the tape winding protruding portion 7 that protrudes in the routing direction of the drawn-out branch line W2. Therefore, the branch line W2 and the branch protector 1H can be firmly fixed by winding the restraint tape T around the branch line W2 and the tape winding protruding portion 7 collectively. As a result, it is possible to reliably prevent the branch protector 1H from being detached from the branch line W2 due to a pulling

16

force acting on the branch line W2, or from causing a relative positional deviation although the branch protector 1H is not detached.

The protector sheet 2A is formed in the bellows-shape except for the component placement portion 2a. Therefore, the winding workability is favorable since the protector sheet 2A can be easily wound around the trunk line W1. The reinforcing protector sheet 21 is also formed in the bellows-shape except for the rigid portion. Therefore, the winding workability is favorable since the reinforcing protector sheet 21 can be easily wound around the trunk line W1.

Each of the tape winding protruding portions 6 and 7 of the trunk line W1 and the branch line W2 is formed like a sheet in a bellows-shape in which a recess and a protrusion are alternately repeated along a protruding direction. Therefore, the trunk line W1 and the branch line W2 drawn out from the branch protector 1H can be easily bent and deformed in an up-down direction UD in the routing directions of the trunk line W1 and the branch line W2, and thus, the routing workability is favorable. Further, the degree of freedom in the routing direction is also high.

The protector sheet 2A is provided with the clip 10. Therefore, the branch protector 1H can be easily fixed to the vehicle body using the clip 10.

Ninth Embodiment

FIGS. 24 to 26 illustrate the ninth embodiment of the invention. A branch protector of the ninth embodiment has two branch protector members, that is, a protector sheet 2B and the reinforcing protector sheet 21, which is similar to the eighth embodiment.

That is, the branch protector includes the protector sheet 2B, the reinforcing protector sheet 21, and a restraint tape (not illustrated) that is wound around the protector sheet 2B, the reinforcing protector sheet 21, and a trunk line (not illustrated), and the protector sheet 2B, the reinforcing protector sheet 21, and a branch line (not illustrated).

Since the protector sheet 2B has the same configuration as that of the second embodiment, the same constituent parts in the drawings will be denoted by the same reference numerals, and the description thereof will be omitted.

Since the reinforcing protector sheet 21 has the same configuration as that of the eighth embodiment, the same constituent parts in the drawings will be denoted by the same reference numerals, and the description thereof will be omitted.

Since assembling work of the branch protector is the same as that of the eighth embodiment, the description thereof will be omitted. A wire harness is assembled by performing mounting of components other than the branch protector to the trunk line and branch line in addition to the assembling of the branch protector

Even in the ninth embodiment, the wire branch portion WD can be protected regardless of a size of the wire branch portion WD, and moreover, it is possible to make the size compact as much as possible, which is similar to the eighth embodiment.

In addition, since the wire branch portion WD is protected by the two sheets of the protector sheet 2B and the reinforcing protector sheet 21, the wire branch portion WD can be firmly protected, which is similar to the eighth embodiment.

The branch protector of the ninth embodiment has the same effects as those of the eighth embodiment in addition to the above-described effects.

FIGS. 27 to 29 illustrate the tenth embodiment of the invention. A branch protector of the tenth embodiment has two branch protector members, that is, the protector sheet 2A and a reinforcing protector plate 22, which is different from the eighth and ninth embodiments.

That is, the branch protector includes the protector sheet 2A, the reinforcing protector plate 22, and a restraint tape (not illustrated) that is wound around the protector sheet 2A, the reinforcing protector plate 22, and a trunk line (not illustrated), and the protector sheet 2A, the reinforcing protector plate 22, and a branch line (not illustrated).

Since the protector sheet 2A has the same configuration as that of the first embodiment, the same constituent parts in the drawings will be denoted by the same reference numerals, and the description thereof will be omitted.

The reinforcing protector plate 22 has an arc shape and has rigidity to maintain the arc shape. The reinforcing protector plate 22 includes a pair of strip-shaped plate portions 28 arranged at intervals by a cut-out portion 27 and two tape winding protruding portions 26 for the trunk line.

Each of the tape winding protruding portions 26 is formed in a bellows-shape in which a recess and a protrusion are alternately repeated along a protruding direction. Therefore, only the respective tape winding protruding portions 26 are easily bent and deformed. Since each of the tape winding protruding portions 26 can be easily bent and deformed in the up-and-down direction UD with respect to a direction of routing the trunk line, the routing workability is favorable. Further, the degree of freedom in the routing direction is also high.

Next, assembling work of the branch protector will be described. As illustrated in FIG. 27, the protector sheet 2A in a developed state is arranged at an assembling work position. Next, the trunk lines (not illustrated) of a wire branch portion (not illustrated) are placed on the component placement portion 2a of the protector sheet 2A and the two tape winding protruding portions 6 for the trunk lines, and the branch line (not illustrated) of the wire branch portion is placed on the tape winding protruding portion 7 for the branch line.

Next, the reinforcing protector plate 22 is placed to cover the wire branch portion as illustrated in FIG. 28.

Next, the protector sheet 2A is wound around the wire branch portion from above the reinforcing protector plate 22 as illustrated in FIG. 29. The winding distal ends of the pair of strip-shaped sheet portions 5 of the protector sheet 2A are wound at the outer side of the protector sheet 2A to overlap each other.

Next, the restraint tape is wound around the protector sheet 2A, the reinforcing protector plate 22, and the respective trunk lines, and the protector sheet 2A, the reinforcing protector plate 22, and the branch line with no gap similarly to the eighth embodiment, and accordingly, the assembling work is completed.

A wire harness is assembled by mounting components other than the branch protector to the trunk line and the branch line.

Even in the tenth embodiment, the wire branch portion can be protected regardless of a size of the wire branch portion, and moreover, it is possible to make the size compact as much as possible, which is similar to the eighth embodiment.

The branch protector of the tenth embodiment has the same effects as those of the eighth embodiment in addition to the above-described effects.

In particular, the wire branch portion can be more firmly protected since the reinforcing protector plate 22 having higher rigidity than the reinforcing protector sheet 21 of the eighth embodiment is used in the tenth embodiment.

In addition, it is enough to place the reinforcing protector plate 22 on the wire branch portion in the tenth embodiment although it is necessary to wind the reinforcing protector sheet 21 around the wire branch portion in the eighth embodiment. Thus, the assembling workability is improved as compared with the eighth embodiment.

Eleventh Embodiment

FIGS. 30 to 32 illustrate the eleventh embodiment of the invention. A branch protector of the eleventh embodiment has two branch protector members, that is, the protector sheet 2B and the reinforcing protector plate 22, which is similar to the tenth embodiment.

Since the protector sheet 2B has the same configuration as that of the second embodiment, the same constituent parts in the drawings will be denoted by the same reference numerals, and the description thereof will be omitted.

Since the reinforcing protector plate 22 has the same configuration as that of the tenth embodiment, the same constituent parts in the drawings will be denoted by the same reference numerals, and the description thereof will be omitted.

Since assembling work of the branch protector is the same as that of the tenth embodiment, the description thereof will be omitted. A wire harness is assembled by performing mounting of components other than the branch protector to the trunk line and branch line in addition to the assembling of the branch protector.

Even in the eleventh embodiment, the wire branch portion can be protected regardless of a size of the wire branch portion, and moreover, it is possible to make the size compact as much as possible, which is similar to the tenth embodiment.

The branch protector of the eleventh embodiment has the same effects as those of the tenth embodiment in addition to the above-described effects.

Twelfth Embodiment

FIGS. 33 and 34 illustrate the twelfth embodiment of the invention. A branch protector of the twelfth embodiment has two branch protector members, that is, a protector plate 29 and the reinforcing protector sheet 21.

That is, the branch protector includes the protector plate 29, the reinforcing protector sheet 21, and a restraint tape (not illustrated) that is wound around the protector plate 29, the reinforcing protector sheet 21, and a trunk line (not illustrated), and the protector plate 29, the reinforcing protector sheet 21, and a branch line (not illustrated).

The protector plate 29 has rigidity at a degree to maintain its own shape even when an external force is applied. The protector plate 29 has a substantially circular arc shape and has basically the same configuration as the configuration of the reinforcing protector plate of the tenth and eleventh embodiments. That is, the protector plate 29 includes the pair of strip-shaped plate portions 28 arranged at intervals by the cut-out portion 27 and the two tape winding protruding portions 26 for the trunk line. A clip mounting portion 29a is provided on a rear surface of the protector plate 29. The clip 10, which is a fixing portion for a vehicle body, is attached to the clip mounting portion 29a.

Since the reinforcing protector sheet **21** has the same configuration as that of the eighth embodiment, the same constituent parts in the drawings will be denoted by the same reference numerals, and the description thereof will be omitted.

Next, assembling work of the branch protector will be described. As illustrated in FIG. **33**, the protector plate **29** is arranged at an assembling work position. Next, the trunk lines (not illustrated) of a wire branch portion (not illustrated) is placed on a bottom surface of the protector plate **29** and the two tape winding protruding portions **6** of the trunk lines, and the branch line (not illustrated) of the wire branch portion (not illustrated) is placed to pass through the cut-out portion **27** of the protector plate **29**.

Next, as illustrated in FIG. **34**, the reinforcing protector sheet **21** is wrapped directly around the wire branch portion exposed from an upper opening of the protector plate **29** and is wound around a part where the wire branch portion (not illustrated) is covered by the protector plate **29** with no gap from the outer side of the protector plate **29**.

Next, the restraint tape (not illustrated) is wound around the protector plate **29**, the reinforcing protector sheet **21**, and the respective trunk lines (not illustrated) with no gap, and accordingly, the assembling work is completed.

A wire harness is assembled by mounting components other than the branch protector to the trunk line and the branch line.

Even in the twelfth embodiment, the wire branch portion can be protected regardless of a size of the wire branch portion, and moreover, it is possible to make the size compact as much as possible, which is similar to the tenth and eleventh embodiments.

The branch protector of the twelfth embodiment has the same effects as those of the tenth and eleventh embodiments in addition to the above-described effects.

Tape winding protruding portions for the branch line (not illustrated) are not provided in both the protector plate **29** and the reinforcing protector sheet **21** in the twelfth embodiment, but may be provided in both or any one of the protector plate **29** and the reinforcing protector sheet **21**.

Thirteenth Embodiment

FIGS. **35** to **42** illustrate a thirteenth embodiment of the invention.

As illustrated in FIGS. **35** to **37**, a branch protector **100A** protects a three-branch wire branch portion **WD**. The branch protector **100A** includes a branch protector main body **102**, which is a main component, and a cover **110**.

The branch protector main body **102** has a bottom wall **103** and a pair of side walls **104** and **105** erected from both side ends of the bottom wall **103**. A wire accommodating chamber **106**, which is surrounded by the bottom wall **103** and the pair of side walls **104** and **105** and has an opened upper surface, is formed in the branch protector main body **102**. Wire draw-out openings **107** are formed at both ends of the pair of side walls **104** and **105**, respectively. The one side wall **104** has a pair of side wall protrusions **104a** at a central part (a position between both the ends of the side wall **104**), and a wire draw-out opening **108** is formed at distal ends of the pair of side wall protrusions **104a**. That is, the three wire draw-out openings **107** and **108** are formed in the side walls **104** and **105** of the branch protector main body **102** in the thirteenth embodiment.

As illustrated in FIG. **38**, the wire branch portion **WD** of the wire (wire bundle) **W** is accommodated in the wire accommodating chamber **106**. Both sides of the trunk line

W1 are drawn to the outside from the two wire draw-out openings **107** at both the ends of the pair of side walls **104** and **105**. The single branch line **W2** is drawn to the outside from the wire draw-out opening **108** at the central part of the one side wall **104**.

The bottom wall **103** is provided with wire fixing protruding portions **109** each of which protrudes from each of the wire draw-out openings **107** and **108** in each direction of routing the trunk lines **W1** and the branch line **W2**. Each of the wire fixing protruding portions **109** is formed in a bellows-shape in which a recess and a protrusion are alternately repeated along a protruding direction.

A clip mounting portion **103a** is provided on an outer surface of the bottom wall **103**. A clip **120**, which is a fixing portion for a vehicle body, is attached to the clip mounting portion **103a**.

The cover **110** is inserted into the wire accommodating chamber **106** through the opening on the upper surface of the wire accommodating chamber **106**. The cover **110** is placed on an upper surface of the wire branch portion **WD** accommodated in the wire accommodating chamber **106**.

The cover **110** has a flat-shaped cover main body **111** and a posture holding wall **112** provided at a circumferential edge of the cover main body **111**. The cover main body **111** is formed in substantially the same shape as the opening shape on the upper surface including the wire accommodating chamber **106** and the three wire draw-out openings **107** and **108** which are continuous to the wire accommodating chamber **106**.

The posture holding wall **112** extends downward from the cover main body **111** in the vertical direction. The posture holding wall **112** is at a position contacting or adjacent to inner surfaces of the wire accommodating chamber **106** and the side walls **104** and **105** of the respective wire draw-out openings **107** and **108** in the state of being positioned inside the wire accommodating chamber **106** (at a position in FIGS. **36** and **39**).

The cover main body **111** is provided with wire fixing protruding portions **113** each of which protrudes from each of the wire draw-out openings **107** and **108** in each of the directions of routing the trunk lines **W1** and the branch line **W2**. Each of the wire fixing protruding portions **113** is formed in a bellows-shape in which a recess and a protrusion are alternately repeated along a protruding direction.

Next, assembling work of the branch protector **100A** will be described. As illustrated in FIG. **38**, the wire branch portion **WD** is accommodated in the wire accommodating chamber **106** of the branch protector main body **102** from the opening on the upper surface thereof. The trunk lines **W1** of the wire **W** are drawn out from the wire draw-out openings **107** at both the ends of the pair of side walls **104** and **105**, respectively. The branch line **W2** of the wire **W** is drawn out from the wire draw-out opening **108** at the central portion of the one side wall **104**.

Next, as illustrated in FIG. **39**, the cover **110** is arranged above the wire accommodating chamber **106** and is dropped to be inserted into the wire accommodating chamber **106**. When the cover **110** does not fall into the wire accommodating chamber **106** due to a dimensional error or the like, a pressing force is applied from above to insert the cover **110**.

The cover **110** is arranged in the wire accommodating chamber **106** in the state of being placed on the wire branch portion **WD**. The wire fixing protruding portions **109** of the branch protector main body **102** are arranged on a lower side of the trunk lines **W1** and the branch line **W2** drawn out from the respective wire draw-out openings **107** and **108**, and the

21

respective wire fixing protruding portions **113** of the cover **110** are arranged on an upper side thereof.

Next, the restraint tape T is wound around parts of the respective wire draw-out openings **107** and **108** of the branch protector **100A** and the trunk lines W1 and the branch line W2 drawn out from the respective wire draw-out openings **107** and **108** as illustrated in FIG. **40**.

Specifically, the restraint tape T is wound collectively around parts of the branch protector main body **102** and the cover **110** at root parts of the pair of upper and lower wire fixing protruding portions **109** and **113**, wound collectively around the pair of upper and lower wire fixing protruding portions **109** and **113** and the trunk lines W1 and the pair of upper and lower wire fixing protruding portions **109** and **113** and the branch line W2 in a range where the pair of upper and lower wire fixing protruding portions **109** and **113** are arranged, and are wound around each outer circumference of the trunk lines W1 and the branch line W2 with no gap at parts where the trunk lines W1 and the branch line W2 are further drawn out from the distal ends of the pair of wire fixing protruding portions **109** and **113**. The assembling work of the branch protector **100A** is completed with winding the restraint tape T.

As described above, the branch protector **100A** includes the branch protector main body **102** whose upper surface is opened and having the wire accommodating chamber **106** accommodating the wire branch portion WD and at least the three wire draw-out openings **107** and **108** from which the respective wires W are drawn out from the wire accommodating chamber **106**, and the cover **110** that is placed on the wire branch portion WD accommodated in the wire accommodating chamber **106** from the opening on the upper surface of the wire accommodating chamber **106** and closes the upper surface of the wire accommodating chamber **106**.

Accordingly, since the cover **110** is placed on the wire branch portion WD accommodated in the wire accommodating chamber **106**, the wire branch portion WD can be accommodated regardless of a size of the wire branch portion WD, and moreover, a useless space is not formed in the wire accommodating chamber **106**. As described above, it is possible to accommodate the wire branch portion WD regardless of the size of the wire branch portion WD, and moreover, it is possible to make the size compact as much as possible. In other words, since the wire accommodating chamber **106** has accommodation capacity corresponding to the size of the wire branch portion WD, it is possible to make the branch protector **100A** compact in accordance with the size of the wire branch portion WD.

For example, when the size of the wire branch portion WD (changing depending on a size of a wire diameter and the number of wires) is smaller than a maximum accommodation capacity of the branch protector **100A**, an external space S is formed on the cover **110** mounted to the branch protector main body **102** as illustrated in FIG. **42**. It is possible to make the branch protector **100A** compact by the amount corresponding to the external space S. The external space S on the cover **110** can be used as an installation space of another component or the like.

Further, in a conventional example, there is a risk that a wire branch portion (not illustrated) moves (vibrates) inside a branch protector **100** so that the wire branch portion (not illustrated) is damaged as an extra space is formed in a wire accommodating chamber **101a** when the wire branch portion (not illustrated) is smaller than the accommodated capacity of the wire accommodating chamber **101a**. In this embodiment, however, the wire branch portion WD does not move

22

(vibrate) inside the branch protector **100A** so that the wire branch portion WD is not damaged.

As the cover **110** is dropped (inserted) between the pair of side walls **104** and **105** of the branch protector main body **102**, the cover **110** is set to a predetermined attachment position of the branch protector main body **102**. Therefore, it is possible to visually confirm that the cover **110** is fitted between the pair of side walls **104** and **105** as illustrated in FIG. **41** after the cover **110** is dropped, and thus, the quality can be improved.

Meanwhile, when the outer circumference of the wire branch portion WD is protected only by the tape winding, there is a risk that a situation where dimensional accuracy is not obtained regarding a wire length to the adjacent wire branch portion (not illustrated) may occur as the wire W is tightened by the tape winding. However, the wire branch portion WD is protected by being accommodated inside the branch protector **1A** in the thirteenth embodiment, and thus, the wire branch portion WD can be protected with the dimensional accuracy regarding the wire length to the adjacent wire branch portion (not illustrated).

The branch protector main body **102** and the cover **110** are provided with the wire fixing protruding portions **109** and **113** protruding from the wire draw-out openings **107** and **108** in the directions of routing the wire W, respectively. Therefore, the branch protector **100A** and the wire W (the trunk line W1 and the branch line W2) can be firmly fixed by winding the restraint tape T around the wire fixing protruding portions **109** and **113** collectively together with the wire W (the trunk line W1 and the branch line W2).

Each of the wire fixing protruding portions **109** and **113** of the branch protector main body **102** and the cover **110** is formed in the bellows-shape. Therefore, the wire W (the trunk line W1 and the branch line W2) drawn out from the branch protector **100A** can be easily bent and deformed in the up-down direction in the directions of routing of the wire W (the trunk line W1 and the branch line W2), and thus, the degree of freedom in the routing direction is high, and the routing workability is favorable.

The cover **110** is provided with the posture holding wall **112** that has substantially the same shape as the opening shape on the upper surface of the wire accommodating chamber **106** and adjacently opposes the inner surfaces of the side walls **104** and **105** of the wire accommodating chamber **106**. Accordingly, a falling posture of the cover **110** is held by the posture holding wall **112** when the cover **110** is dropped (inserted) into the wire accommodating chamber **106** through the opening on the upper surface of the wire accommodating chamber **106**, and thus, the cover **110** falls onto the wire branch portion WD of the wire accommodating chamber **106** without being inclined and is placed on the wire branch portion WD.

The posture holding wall **112** extends downward from the cover main body **111** in the vertical direction. Therefore, since the posture holding wall **112** does not protrude upward from the cover main body **111**, it is possible to prevent inclination of the cover **110** at the time of falling while securing the external space S that can be formed on the cover **110** attached to the branch protector main body **102**.

The branch protector main body **102** is provided with the clip **120**. Therefore, the branch protector **100A** can be easily fixed to the vehicle body using the clip **120**.

As illustrated in FIG. **42**, since a load from the cover **110** is easily transmitted to the clip **120** via the wire branch portion WD, it is easy to perform fixing work to the vehicle body.

FIGS. 43 and 44 illustrate a fourteenth embodiment of the invention. A branch protector 100B of the fourteenth embodiment is provided with a protruding portion 121 protruding inside the wire accommodating chamber 106 on the bottom wall 103 as compared with the thirteenth embodiment. The protruding portion 121 is provided at a position right above the clip 120. The protruding portion 121 is set to have substantially the same height as an assumed height of the wire branch portion WD. That is, the protruding portion 121 has a dimension to abut on a lower surface of the cover 110 mounted to the branch protector main body 102 or to reach near the lower surface of the cover 110. The protruding portion 121 has a cylindrical shape.

The protruding portion 121 is arranged in the state of skewering the wire branch portion WD in a state where the wire branch portion WD is accommodated in the wire accommodating chamber 106.

Since other configurations are the same as those of the thirteenth embodiment, the same constituent parts in the drawings will be denoted by the same reference numerals, and the description thereof will be omitted.

Even in the fourteenth embodiment, the cover 110 is placed on the wire branch portion WD accommodated in the wire accommodating chamber 106, and thus, the wire branch portion WD can be accommodated regardless of a size of the wire branch portion WD, and moreover, a useless space is not formed in the wire accommodating chamber 106, which is similar to the thirteenth embodiment. As described above, it is possible to accommodate the wire branch portion WD regardless of the size of the wire branch portion WD, and moreover, it is possible to make the size compact as much as possible.

The branch protector main body 102 is provided with the protruding portion 121 protruding from the bottom wall 103 inside the wire accommodating chamber 106. Therefore, a load from the cover 110 is more easily transmitted to the clip 120 via the protruding portion 121 than in the case of the thirteenth embodiment, and thus, a fixing operation to a vehicle body becomes easier. Since the protruding portion 121 is positioned right above the clip 120, the load from the cover 110 is more easily transmitted to the clip 120 via the protruding portion 121, so that the fixing operation to the vehicle body is further facilitated. In a case where the size of the wire branch portion WD is smaller than an assumed size, the protruding portion 121 is cut to be short so as not to interfere with the cover 110 and used.

The protruding portion 121 is arranged in the state of skewering the wire branch portion WD. Therefore, the protruding portion 121 also functions as a fixing portion between the wire branch portion WD and the branch protector main body 102, and also functions as a portion positioning the wire branch portion WD inside the wire accommodating chamber 106.

The protruding portion 121 has the cylindrical shape. Therefore, since the cylindrical shape has no edge, the wire W is not damaged by the edge.

Fifteenth Embodiment

FIGS. 45 to 47 illustrate a fifteenth embodiment of the invention. A branch protector 100C of the fifteenth embodiment has four wire draw-out openings 107 and 108 as compared with that of the thirteenth embodiment. That is, a pair of side wall protruding portions 105a is also provided

on the other side wall 105, and the wire draw-out opening 108 is provided at a distal end of the pair of side wall protruding portions 105a.

The branch protector 100C can protect a wire branch portion (not illustrated) from which four wires (two trunk lines and two branch lines in this embodiment) extend in different directions.

Since other configurations are the same as those of the thirteenth embodiment, the same constituent parts in the drawings will be denoted by the same reference numerals, and the description thereof will be omitted.

Even in the fifteenth embodiment, the cover 110 is placed on the wire branch portion (not illustrated) accommodated in the wire accommodating chamber 106, and thus, the wire branch portion (not illustrated) can be accommodated regardless of a size of the wire branch portion (not illustrated), and moreover, a useless space is not formed in the wire accommodating chamber 106, which is similar to the thirteenth embodiment. As described above, it is possible to accommodate the wire branch portion (not illustrated) regardless of the size of the wire branch portion (not illustrated), and moreover, it is possible to make the size compact as much as possible.

As illustrated in FIG. 47, the branch protector 100C of the fifteenth embodiment can be also used to protect a wire branch portion (not illustrated) from which three wires (two trunk lines W1 and one branch line W2) extend in different directions. In this case, since the one wire draw-out opening 108 is not used, this unused wire draw-out opening 108 is closed with the wire fixing protruding portions 109 and 113. For example, the wire fixing protruding portion 109 on the branch protector main body 102 is cut, and the wire fixing protruding portion 113 on the cover 110 is bent to close the wire draw-out opening 108, and the bent and deformed wire fixing protruding portion 113 is fixed to the branch protector main body 102 by the restraint tape T.

Sixteenth Embodiment

FIGS. 48 and 49 illustrate a sixteenth embodiment of the invention. A branch protector 100D of the sixteenth embodiment is different from the thirteenth embodiment in terms of the following point. That is, the cover 110 is provided with the wire fixing protruding portion 113 protruding in a direction of routing a trunk line (not illustrated) from each of the wire draw-out openings 107 similarly to the thirteenth embodiment. However, the cover 110 is not provided with a wire fixing protruding portion protruding in a direction of routing a branch line (not illustrated) from the wire draw-out opening 108.

Since other configurations are the same as those of the thirteenth embodiment, the same constituent parts in the drawings will be denoted by the same reference numerals, and the description thereof will be omitted.

A tape is wound around the branch line (not illustrated) drawn out from the branch protector 100D collectively with the wire fixing protruding portion 109 on the branch protector main body 102.

Even in the sixteenth embodiment, the cover 110 is placed on the wire branch portion (not illustrated) accommodated in the wire accommodating chamber 106, and thus, the wire branch portion (not illustrated) can be accommodated regardless of a size of the wire branch portion (not illustrated), and moreover, a useless space is not formed in the wire accommodating chamber 106, which is similar to the thirteenth embodiment. As described above, it is possible to accommodate the wire branch portion (not illustrated)

regardless of the size of the wire branch portion (not illustrated), and moreover, it is possible to make the size compact as much as possible.

Since the wire fixing protruding portion **109** for the branch line is provided only on the branch protector main body **102**, it is easy to wind the tape when a total diameter of the branch line **W2** is extremely smaller than a total diameter of the trunk line **W1**.

Seventeenth Embodiment

FIGS. **50** and **51** illustrate a seventeenth embodiment of the invention. A branch protector **100E** of the seventeenth embodiment is different from the thirteenth embodiment in terms of the following point. That is, the wire fixing protruding portion **113** protruding in a direction of routing the trunk line **W1** (illustrated in FIG. **85**) from each of the wire draw-out openings **107** on the cover **110** is provided similarly to the thirteenth embodiment. However, there is no wire fixing protruding portion protruding in a direction of routing the branch line **W2** (illustrated in FIG. **85**) from the wire draw-out opening **108** on the cover **110** similarly to the sixteenth embodiment.

In addition, the wire fixing protruding portion **109** protruding in a direction of routing the branch line **W2** (illustrated in FIG. **85**) from the wire draw-out opening **108** on the branch protector main body **102** does not have a bellows-shape but is a flexible rod **109a**. Spherical protrusions **109b** are provided to protrude from the flexible rod **109a** with intervals

Since other configurations are the same as those of the thirteenth embodiment, the same constituent parts in the drawings will be denoted by the same reference numerals, and the description thereof will be omitted.

A tape is wound around the branch line **W2** (illustrated in FIG. **85**) drawn out from the branch protector **100E** collectively with the wire fixing protruding portion **109** on the branch protector main body **102**.

Even in the seventeenth embodiment, the cover **110** is placed on the wire branch portion (not illustrated) accommodated in the wire accommodating chamber **106**, and thus, the wire branch portion (not illustrated) can be accommodated regardless of a size of the wire branch portion (not illustrated), and moreover, a useless space is not formed in the wire accommodating chamber **106**, which is similar to the thirteenth embodiment. As described above, it is possible to accommodate the wire branch portion (not illustrated) regardless of the size of the wire branch portion (not illustrated), and moreover, it is possible to make the size compact as much as possible.

Since the wire fixing protruding portion **109** for the branch line is provided only on the branch protector main body **102**, it is easy to wind the tape when a total diameter of the branch line **W2** is extremely smaller than a total diameter of the trunk line **W1**.

The wire fixing protruding portion **109** for the branch line is the flexible rod **109a**, and thus, can be easily bent and deformed not only in the up-down direction **UD** but also in a left-right direction **LR**. Therefore, it is possible to three-dimensionally change the direction of routing the branch line **W2** (illustrated in FIG. **85**) drawn out from the wire draw-out opening **108**, and further, the assembling workability is more favorable and the degree of freedom in routing is also higher as compared with the thirteenth to sixteenth embodiments.

The wire fixing protruding portion **109** for the branch line has the spherical protrusions **109b** at intervals. Therefore,

the restraint tape **T** (illustrated in FIG. **86**) is wound so as to eat into the spherical protrusion **109b**, and thus, the branch line **W2** (illustrated in FIG. **85**) and the branch protector **100E** can be firmly fixed.

(Manufacturing Method Using Jig Pin)

Next, an assembling procedure (a manufacturing method) of the branch protector **1A** and the like of each of the embodiments using jig pins **51** will be described.

As illustrated in FIG. **52A**, the two jig pins **51** are erected on a jig base **50** with an interval therebetween. Each of the jig pins **51** includes a vertical portion **52** whose proximal end is supported by the jig base **50**, a horizontal holding portion **53** horizontally extending from a distal end of the vertical portion **52**, and two vertical holding portions **54** erected from each end of the horizontal holding portion **53**. The horizontal holding portions **53** and the vertical holding portions **54** of the two jig pins **51** are oriented in the same directions, respectively.

Assembling of First Embodiment

First, as illustrated in FIG. **52B**, the protector sheet **2A** in the developed state is placed on the two jig pins **51**, and the protector sheet **2A** is supported in a floating state from the jig base **50** (a component setting step).

Next, the wire branch portion **WD** is placed on the protector sheet **2A** as illustrated in FIG. **53**. Next, the protector sheet **2A** is wound around the outer circumference of the wire branch portion **WD** as illustrated in FIG. **54**. Next, as illustrated in FIG. **55**, the restraint tape **T** is wound around draw-out points of the trunk line **W1** and the branch line **W2** while holding the winding state of the protector sheet **2A** (an assembling step). Accordingly, the assembling of the branch protector **1A** of the first embodiment is completed.

Incidentally, when a part of the jig pin **51** has trouble in the assembling work, a position of the protector sheet **2A** or the like on the jig pin **51** is appropriately shifted. This is also similarly applied to the following assembling work.

Assembling of Eighth Embodiment

Assembling is performed in the same manner as the first embodiment up to a state in FIG. **56**. Thereafter, as illustrated in FIG. **56**, the reinforcing protector sheet **21** is placed to cover the protector sheet **2A** from above. Next, as illustrated in FIG. **57**, the reinforcing protector sheet **21** is wound around the protector sheet **2A** to overlap each other. Next, as illustrated in FIG. **58**, the restraint tape **T** is wound around draw-out points of the trunk line **W1** and the branch line **W2** while holding the winding states of the protector sheet **2A** and the reinforcing protector sheet **21**. Accordingly, the assembling of the branch protector **1H** of the eighth embodiment is completed.

Assembling of Tenth Embodiment

Assembling is performed in the same manner as the first embodiment up to a state in FIG. **53**. Thereafter, as illustrated in FIGS. **59** and **60**, the reinforcing protector plate **22** is placed to cover the wire branch portion **WD** from above. Next, the protector sheet **2A** is wound above the reinforcing protector plate **22** to overlap each other as illustrated in FIG. **61**. Next, as illustrated in FIG. **62**, the restraint tape **T** is wound around draw-out points of the trunk line **W1** and the branch line **W2** while holding the winding state of the

protector sheet 2A. Accordingly, the assembling of the branch protector 1 of the tenth embodiment is completed.

Assembling of Second Embodiment

First, as illustrated in FIG. 63, the protector sheet 2B in the developed state is placed on the two jig pins 51, and the protector sheet 2B is supported in a floating state from the jig base 50 (a component setting step).

Next, the wire branch portion WD is placed on the protector sheet 2B as illustrated in FIG. 64. Next, the protector sheet 2B is wound around the outer circumference of the wire branch portion WD as illustrated in FIG. 65. Next, as illustrated in FIG. 66, the restraint tape T is wound around draw-out points of the trunk line W1 and the branch line W2 while holding the winding state of the protector sheet 2B (an assembling step). Accordingly, the assembling of the branch protector 1B of the second embodiment is completed.

Assembling of Ninth Embodiment

Assembling is performed in the same manner as the second embodiment up to a state in FIG. 65. Thereafter, as illustrated in FIG. 67, the reinforcing protector sheet 21 is placed on the protector sheet 2B to cover the protector sheet 2B. Next, as illustrated in FIG. 68, the reinforcing protector sheet 21 is wound from above the protector sheet 2B to overlap each other. Next, as illustrated in FIG. 69, the restraint tape T is wound around draw-out points of the trunk line W1 and the branch line W2 while holding the winding states of the protector sheet 2B and the reinforcing protector sheet 21. Accordingly, the assembling of a branch protector 1I of the ninth embodiment is completed.

Assembling of Eleventh Embodiment

Assembling is performed in the same manner as the second embodiment up to a state in FIG. 64. Thereafter, as illustrated in FIGS. 70 and 71, the reinforcing protector plate 22 is placed to cover the wire branch portion WD from above. Next, the protector sheet 2B is wound from above the reinforcing protector plate 22 as illustrated in FIG. 72. Next, as illustrated in FIG. 73, the restraint tape T is wound around draw-out points of the trunk line W1 and the branch line W2 while holding the winding state of the protector sheet 2B. Accordingly, the assembling of a branch protector 1K of the eleventh embodiment is completed.

Assembling of Twelfth Embodiment

First, as illustrated in FIG. 74, the reinforcing protector plate 29 is placed on the two jig pins 51, and the reinforcing protector plate 29 is supported in the floating state from the jig base 50 (a component setting step).

Next, the wire branch portion WD is placed on the reinforcing protector plate 29 as illustrated in FIG. 75. Next, the protector sheet 21 is placed to cover the wire branch portion WD from above as illustrated in FIG. 76. Next, the protector sheet 21 is wound from above the reinforcing protector plate 29 as illustrated in FIG. 77. Next, as illustrated in FIG. 78, the restraint tape T is wound around draw-out points of the trunk line W1 and the branch line W2 while holding the winding state of the protector sheet 21 (an assembling step). Accordingly, the assembling of a branch protector 1L of the twelfth embodiment is completed.

Assembling of Third to Seventh Embodiments: Not Illustrated

Regarding the branch protectors of the third to seventh embodiments, assembling may be performed in each assembling procedure of the branch protectors 1A and 1B of the first and second embodiments using each of the protector sheets 2C to 2G.

Assembling of Thirteenth Embodiment

First, as illustrated in FIG. 79, the branch protector main body 102 is placed on the two jig pins 51, and the branch protector main body 102 is supported in the floating state from the jig base 50 (a component setting step).

Next, as illustrated in FIG. 80, the wire branch portion WD is accommodated in the wire accommodating chamber 106 of the branch protector main body 102. The trunk lines W1 of the wire W are drawn out from the wire draw-out openings 107 at both the ends of the pair of side walls 104 and 105, respectively. The branch line W2 of the wire W is drawn out from the wire draw-out opening 108 at the central portion of the one side wall 104.

Next, as illustrated in FIG. 81, the cover 110 is arranged above the wire accommodating chamber 106, and the cover 110 is dropped to be inserted into the wire accommodating chamber 106.

Next, as illustrated in FIG. 82, the restraint tape T is wound around the portions of the wire draw-out openings 107 and 108 of the branch protector 100A and the trunk line W1 and the branch line W2 drawn out from the respective wire draw-out openings 107 and 108 (an assembling step). Thus, the assembling of the branch protector 100C of the thirteenth embodiment is completed.

Assembling of Fourteenth and Fifteenth Embodiments: Not Illustrated

Regarding the branch protectors 100B and 100C of the fourteenth and fifteenth embodiments, the branch protector main body 102 and the cover 110 of each of the branch protectors 100B and 100C may be used to perform assembling in accordance with the assembling procedure of the branch protector 100A of the thirteenth embodiment.

Assembling of Sixteenth Embodiment

The branch protector 100D of the sixteenth embodiment may be assembled in accordance with the assembling procedure of the branch protector 100A of the thirteenth embodiment.

However, as illustrated in FIG. 83, the cover 110 is not provided with a wire fixing protruding portion protruding in a direction of routing a branch line (not illustrated) from the wire draw-out opening 108. Therefore, a tape is wound around the branch line (not illustrated) drawn out from the branch protector 100D only with the wire fixing protruding portion 109 on the branch protector main body 102. Thus, the assembling of the branch protector 100D of the sixteenth embodiment is completed.

Assembling of Seventeenth Embodiment

The branch protector 100E of the seventeenth embodiment may be assembled in accordance with the assembling procedure of the branch protector 100A of the thirteenth embodiment.

29

More specifically, the branch protector main body **102** is placed on the two jig pins **51**, and the branch protector main body **102** is supported in the floating state from the jig base **50** (a component setting step).

Next, as illustrated in FIG. **84**, the wire branch portion **WD** is accommodated in the wire accommodating chamber **106** of the branch protector main body **102**. The trunk lines **W1** of the wire **W** are drawn out from the wire draw-out openings **107** at both the ends of the pair of side walls **104** and **105**, respectively. The branch line **W2** of the wire **W** is drawn out from the wire draw-out opening **108** at the central portion of the one side wall **104**.

Next, as illustrated in FIG. **85**, the cover **110** is arranged above the wire accommodating chamber **106**, and the cover **110** is dropped to be inserted into the wire accommodating chamber **106**.

Next, as illustrated in FIG. **86**, the restraint tape **T** is wound around the portions of the wire draw-out openings **107** and **108** of the branch protector **100E** and the trunk line **W1** and the branch line **W2** drawn out from the respective wire draw-out openings **107** and **108** (an assembling step). The branch line **W2** drawn out from the branch protector **100E** is wound collectively around the flexible rod **109a** attached with the spherical protrusion **109b**. Thus, the assembling of the branch protector **100E** of the seventeenth embodiment is completed.

Next, the assembling procedure (manufacturing method) of the branch protector **1A**, **1B**, **1H** to **1L**, and **100A** to **100E** of the respective embodiments using the jig pin **51** has been described above.

In this assembling procedure (manufacturing method), the protector sheets **2A** and **2B**, the reinforcing protector plate **29**, and the branch protector main body **102**, which are the main components of the branch protectors **1A** to **1L** (there are missing numbers), are supported by the jig pins **51** in the floating state from the jig base **50**, and the space below the protector sheets **2A** and **2B**, the reinforcing protector plate **29**, and the branch protector main body **102** can also be used as an assembling work space. Therefore, the tape winding of the restraint tape **T** can be easily performed in each of the above-described embodiments, and the assembling workability is favorable. Incidentally, it is possible to easily perform the assembling work other than the tape winding of the restraint tape **T**.

(Modification of Protector Sheet)

FIG. **87** illustrates a first modification of the protector sheet **2B**. In the first modification of the protector sheet **2B**, a cut-out portion **5a** is formed in each of the pair of strip-shaped sheet portions **5**. When positioning with the jig pin **51** is performed at each of the cut-out portions **5a**, the protector sheet **2B** can be reliably supported by the jig pins **51** in the floating state from the jig base **50**.

FIG. **88** illustrates a second modification of the protector sheet **2B**. In the second modification of the protector sheet **2B**, a groove **5b** is formed in each of the pair of strip-shaped sheet portions **5**. When positioning with the jig pin **51** is performed at each of the grooves **5b**, the protector sheet **2B** can be reliably supported by the jig pins **51** in the floating state from the jig base **50**.

FIG. **85** illustrates a first modification of the protector sheet **2C**. In the first modification of the protector sheet **2C**, a groove **6d** is formed in each of the pair of tape winding protruding portions **6**, and the cut-out portion **5a** is formed in each of the wire strip-shaped sheet portions **5**. When positioning with the jig pin **51** is performed at each of the

30

cut-out portions **5a**, the protector sheet **2B** can be reliably supported by the jig pins **51** in the floating state from the jig base **50**.

Incidentally, the number of the jig pins **51** used in the manufacturing method of each of the embodiments is two, but may be one or three or more. Further, the form of the jig pin **51** is also bifurcated, but it may be trifurcated or higher. The form of the jig pin **51** is appropriately changed in accordance with the form of the main component.

Modification of First to Twelfth Embodiments

Although the restraint tape **T** is wound directly around the outer circumference of the wire **W** in the first to twelfth embodiments, the restraint tape **T** is wound above a corrugated tube when the corrugated tube is attached to the wire **W**.

Although the one trunk line (wire bundle) **W1** and the one branch line (wire bundle) **W2** are drawn out from the trunk line draw-out opening **8** and the branch line draw-out opening **9**, respectively, in the first to twelfth embodiments, a plurality of trunk lines (wire bundles) **W1** and a plurality of branch lines (wire bundles) **W2** may be drawn out therefrom. Here, the one trunk line (wire bundle) **W1** and the one branch line (wire bundle) **W2** are those routed along the same routing path.

The component placement portions **2a** of the protector sheets **2A** to **2E** are formed as the flat plate portion in the first to twelfth embodiments, but may be formed in the bellows-shape.

Although the single cut-out portion **4** is provided in the first to twelfth embodiments, a plurality of cut-out portions **4** may be provided. The branch line (wire bundle) **W2** may be drawn out from each of the cut-out portions **4**, **24**, and **27**.

In the first to fifth embodiments and the eighth to twelfth embodiments, the tape winding protruding portion **7** for the branch line may be formed in the flexible rod **7a** having the spherical protrusions **7b** with the interval therebetween similarly to the fifth and sixth embodiments.

Modification of Thirteenth to Seventeenth Embodiments

Although the restraint tape **T** is wound directly around the outer circumference of the wire **W** in the thirteenth to seventeenth embodiments, the restraint tape **T** is wound above a corrugated tube when the corrugated tube is attached to the wire **W**.

In the thirteenth to fifteenth embodiments, both the branch protector main body **102** and the cover **110** are provided with the wire fixing protruding portions **109** and **113** protruding from the wire draw-out openings **107** and **108** in the routing direction of the wire **W**. Any one of the branch protector main body **102** and the cover **110** (the sixteenth and seventeenth embodiments correspond to specific examples of this modification) may be provided with the wire fixing protruding portions **109** and **113** protruding from the wire draw-out openings **107** and **108** in the routing direction of the wire **W**. In this case, it is necessary to provide a means for fixing between the branch protector main body **102** and the cover **110** in some cases.

Although the branch protectors **100A** to **100C** and the wires **W** (the trunk line **W1** and the branch line **W2**) are fixed by winding the restraint tape **T** collectively around the wire fixing protruding portions **109** and **113** together with the wires **W** (the trunk line **W1** and the branch line **W2**) in the thirteenth to seventeenth embodiments, the branch protec-

31

tors 100A to 100C and the wires W (the trunk line W1 and the branch line W2) may be fixed by collectively fastening the wire fixing protruding portions 109 and 113 together with the wires W (the trunk line W1 and the branch line W2) using a binding band.

The wire draw-out openings 107 and 108 are provided on the side walls 104 and 105, respectively, in the thirteenth to fifteenth embodiments, but may be provided on the bottom wall 103 or may be provided across the side walls 104 and 105 and the bottom wall 103.

The single wire (wire bundle) W is drawn out from the wire draw-out openings 107 and 108 in the thirteenth to fifteenth embodiments, but a plurality of wires (wire bundle) may be drawn out. For example, although the single branch line (wire bundle) W2 is drawn out from the wire draw-out opening 108, a plurality of branch lines (wire bundle) W2 may be drawn out. Here, the single wire (wire bundle) W means one routed along the same routing path.

What is claimed is:

1. A method of manufacturing a branch protector comprising:

a component setting step of supporting a main component in a floating state from a jig base on a jig pin erected on the jig base; and

an assembling step of assembling a wire branch portion to the main component, wherein

the main component includes a first opening and a second opening, during the assembling step, such that a trunk line of the wire branch portion extends out of the main component through the first opening and a branch line of the wire branch portion extends out of the main component through the second opening,

the main component further includes a tape winding protruding portion that extends outward from the first opening or the second opening during the assembling step,

in the assembling step, a restraint tape is wound collectively around the tape winding protruding portion of the main component and the wire branch portion, such that the restraint tape is in direct contact with the tape winding protruding portion and wires of the wire branch portion,

the main component is a flexible protector sheet, in the component setting step, the protector sheet in a developed state is supported by the jig pin, and

in the assembling step, the wire branch portion is placed on the protector sheet, the protector sheet is wound around an outer circumference of the wire branch portion, and the restraint tape is wound collectively around the tape winding protruding portion of the protector sheet from which the trunk line of the wire branch portion is drawn out and the trunk line, such that the restraint tape is in direct contact with the tape winding protruding portion and wires of the trunk line.

2. A method of manufacturing a branch protector comprising:

a component setting step of supporting a main component in a floating state from a jig base on a jig pin erected on the jig base; and

an assembling step of assembling a wire branch portion to the main component, wherein

the main component includes a first opening and a second opening, during the assembling step, such that a trunk line of the wire branch portion extends out of the main component through the first opening and a branch line of the wire branch portion extends out of the main component through the second opening,

32

the main component further includes a tape winding protruding portion that extends outward from the first opening or the second opening during the assembling step,

in the assembling step, a restraint tape is wound collectively around the tape winding protruding portion of the main component and the wire branch portion, such that the restraint tape is in direct contact with the tape winding protruding portion and wires of the wire branch portion,

the main component is a flexible protector sheet, the tape winding protruding portion of the flexible protector sheet extends outward from the first opening, through which the trunk line of the wire branch portion extends, during the assembling step,

in the component setting step, the protector sheet in a developed state is supported by the jig pin, and

in the assembling step, the wire branch portion is placed on the protector sheet, the protector sheet is wound around an outer circumference of the wire branch portion, a reinforcing protector member is further arranged on the outer circumference of the wire branch portion, and the restraint tape is wound collectively around the tape winding protruding portion of the protector sheet, a tape winding protruding portion of the reinforcing protector member, from which the trunk line of the wire branch portion is drawn out, and the trunk line, such that the restraint tape is in direct contact with the tape winding protruding portion of the protector sheet, the tape winding protruding portion of the reinforcing protector member, and the trunk line.

3. A method of manufacturing a branch protector comprising:

a component setting step of supporting a main component in a floating state from a jig base on a jig in erected on the jig base; and

an assembling step of assembling a wire branch portion to the main component, wherein

the main component includes a first opening and a second opening, during the assembling step, such that a trunk line of the wire branch portion extends out of the main component through the first opening and a branch line of the wire branch portion extends out of the main component through the second opening,

the main component further includes a tape winding protruding portion that extends outward from the first opening or the second opening during the assembling step,

in the assembling step, a restraint tape is wound collectively around the tape winding protruding portion of the main component and the wire branch portion, such that the restraint tape is in direct contact with the tape winding protruding portion and wires of the wire branch portion,

the main component is a reinforcing protector plate having rigidity to maintain a form of a circular arc shape, the tape winding protruding portion of the reinforcing protector plate extends outward from the first opening, through which the trunk line of the wire branch portion extends, during the assembling step,

in the component setting step, the reinforcing protector plate is supported by the jig pin,

in the assembling step, the wire branch portion is placed on the reinforcing protector plate, a protector sheet is wound around an outer circumference of the wire branch portion, and the restraint tape is wound collectively around the tape winding protruding portion of the

33

reinforcing protector plate, a tape winding protruding portion of the protector sheet, from which the trunk line of the wire branch portion is drawn out, and the trunk line, such that the restraint tape is in direct contact with the tape winding protruding portion of the reinforcing protector plate, the tape winding protruding portion of the protector sheet, and the trunk line, and

the tape winding protruding portion of the protector sheet extends outward from the first opening, through which the trunk line of the wire branch portion extends, during the assembling step.

4. The method of manufacturing a branch protector according to claim 1, wherein

the tape winding protruding portion of the main component extends outward from the second opening, through which the branch line of the wire branch portion extends, during the assembling step,

in the assembling step, the restraint tape is wound collectively around the tape winding protruding portion of the main component, from which the branch line of the wire branch portion is drawn out, and the branch line.

5. A method of manufacturing a branch protector comprising:

a component setting step of supporting a main component in a floating state from a jig base on a jig pin erected on the jig base; and

an assembling step of assembling a wire branch portion to the main component, wherein

the main component includes a first opening and a second opening, during the assembling step, such that a trunk line of the wire branch portion extends out of the main component through the first opening and a branch line of the wire branch portion extends out of the main component through the second opening,

the main component further includes a tape winding protruding portion that extends outward from the first opening or the second opening during the assembling step,

in the assembling step, a restraint tape is wound collectively around the tape winding protruding portion of the main component and the wire branch portion, such that the restraint tape is in direct contact with the tape winding protruding portion and wires of the wire branch portion,

the main component is a branch protector main body having a wire accommodating chamber whose upper surface is opened,

the tape winding protruding portion of the branch protector main body extends outward from the first opening, through which the trunk line of the wire branch portion extends,

in the component setting step, the branch protector main body is supported by the jig pin,

in the assembling step, the wire branch portion is accommodated in the wire accommodating chamber of the branch protector main body, a cover is arranged on the wire accommodating chamber from above the wire branch portion, and the restraint tape is wound collectively around a the tape winding protruding portion of the branch protector main body and/or a tape winding protruding portion of the cover, from which a trunk line of the wire branch portion is drawn out, and the trunk line, and

the tape winding protruding portion of the cover extends outward from the first opening, through which the trunk line of the wire branch portion extends, during the assembling step.

34

6. The method of manufacturing a branch protector according to claim 5, wherein

the main component includes an additional tape winding protruding portion that extends outward from the second opening, through which the branch line of the wire branch portion extends,

in the assembling step, the restraint tape is wound around the additional tape winding protruding portion of the branch protector main body and/or an additional tape winding protruding portion of the cover from which a branch line of the wire branch portion is drawn out, and the branch line, and

the additional tape winding protruding portion of the cover extends outward from the second opening, through which the branch line of the wire branch portion extends, during the assembling step.

7. A wire harness comprising a branch protector manufactured by the method of manufacturing a branch protector according to claim 1.

8. A method of manufacturing a branch protector comprising:

a component setting step of supporting a main component in a floating state from a jig base on a jig pin erected on the jig base; and

an assembling step of assembling a wire branch portion to the main component, wherein

the main component includes a first opening and a second opening, during the assembling step, such that a trunk line of the wire branch portion extends out of the main component through the first opening and a branch line of the wire branch portion extends out of the main component through the second opening,

the main component further includes a tape winding protruding portion that extends outward from the first opening or the second opening during the assembling step,

in the assembling step, a restraint tape is wound collectively around the tape winding protruding portion of the main component and the wire branch portion, such that the restraint tape is in direct contact with the tape winding protruding portion and wires of the wire branch portion, and

the tape winding protruding portion has a sheet shape that, in the assembling step, contacts the wire branch portion on only a single side of the wire branch portion, in a radial direction of the wire branch portion.

9. The method of manufacturing a branch protector according to claim 8, wherein the tape winding protruding portion includes bellows.

10. A method of manufacturing a branch protector comprising:

a component setting step of supporting a main component in a floating state from a jig base on a jig pin erected on the jig base; and

an assembling step of assembling a wire branch portion to the main component, wherein

the main component includes a first opening and a second opening, during the assembling step, such that a trunk line of the wire branch portion extends out of the main component through the first opening and a branch line of the wire branch portion extends out of the main component through the second opening,

the main component further includes a tape winding protruding portion that extends outward from the first opening or the second opening during the assembling step,

in the assembling step, a restraint tape is wound collectively around the tape winding protruding portion of the main component and the wire branch portion, such that the restraint tape is in direct contact with the tape winding protruding portion and wires of the wire branch portion, and

the tape winding protruding portion is a flexible rod that, in the assembling step, contacts the wire branch portion on only a single side of the wire branch portion, in a radial direction of the wire branch portion, in the assembling step.

11. The method of manufacturing a branch protector according to claim **10**, wherein the tape winding protruding portion includes spherical protrusions.

* * * * *