

C. NASH.

Improvement in Plows.

No. 132,406.

Patented Oct. 22, 1872.

Fig. 1.

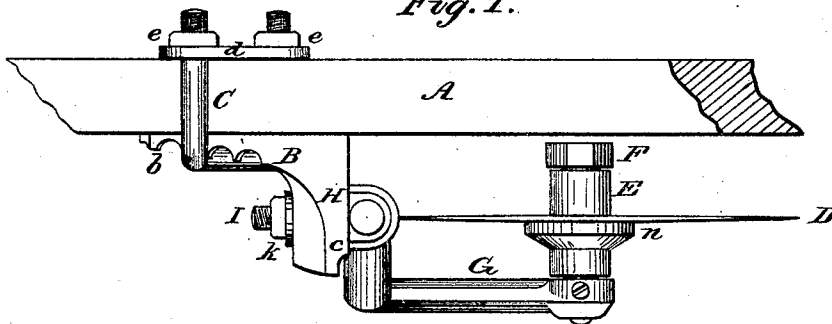

Fig. 2.

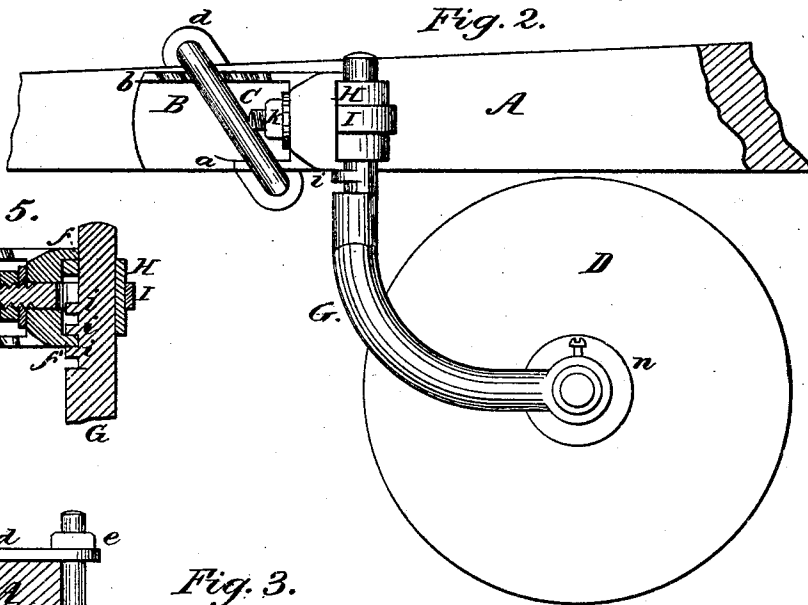

Fig. 5.

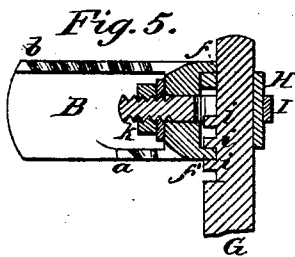

Fig. 3.

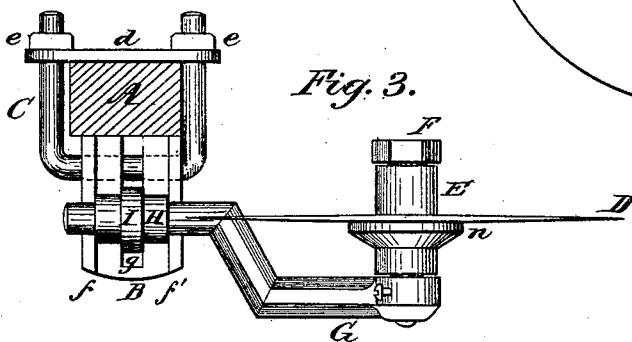
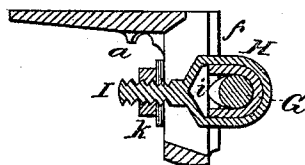

Fig. 4.



Witnesses.  
Jacob Behel.  
J. S. Marlone.

Inventor.  
Chester Nash.

# UNITED STATES PATENT OFFICE.

CHESTER NASH, OF BACON, ILLINOIS.

## IMPROVEMENT IN PLOWS.

Specification forming part of Letters Patent No. 132,406, dated October 22, 1872.

*To all whom it may concern:*

Be it known that I, CHESTER NASH, of Bacon, in the county of Ogle and State of Illinois, have invented certain Improvements in Rolling Colters, of which the following is a specification:

The first part of the invention relates to the bracket by means of which the colter is secured to the plow-beam; and consists in providing this bracket with a series of notches or flutings upon its outer face, whereby its position upon the beam may be adjusted at will without changing the position of the clamping-stirrup or screw-staple, and without the employment of any additional pieces. The second part of the invention consists in securing the colter-shank to the bracket by means of an inclosing and supporting-box and an eye-bolt, the face of the bracket being provided with two horizontal flanges between which the box fits, the shank having upon one side a series of notches, into any one of which one of the flanges may be made to enter for the purpose of adjusting the height of the colter, the bracket being slotted so as to permit the colter to be adjusted laterally, as will be fully explained.

Figure 1 is a plan view embodying my invention. Fig. 2 is a side elevation. Fig. 3 is a rear-end view. Fig. 4 is a center horizontal section of the joint. Fig. 5 is a center vertical section of the joint.

A is a portion of a plow-beam, which may be any of the usual or proper forms. B is a bracket fitted to beam A, the forward portion of which is provided with raised flanges *a* and *b*. The flange *a*, near the angle formed by the projecting arm *c*, is fluted to receive the screw-staple clamp C in such a manner as will permit the upper portion thereof to be moved backward or forward, the inner portion of the fluting being widened for the purpose. The flange *b* is provided with a series of radial flutings radiating from the fluting in *a*. These flutings are also to receive the screw-staple clamp, and are for the purpose of raising or lowering the rear end of the bracket, by means of which the rolling colter may be set to run at a greater or less depth. C is a screw-staple clamp which embraces the bracket B and beam A, and is provided with clamp-plate *d* and screw-nuts *e e*, by means of which the bracket B is held in

place on beam A, and may be adjusted longitudinally thereon, and set to run at a greater or less depth. The projecting arm *c* of bracket B is provided with flanges *f f'*, and is also provided with a horizontal slot, *g*. D is a rolling colter of suitable size, constructed as it is usual to construct such colters, and is secured on hub E to collar *n* by rivets or otherwise. Hub E is bored to receive stud-journal F, which is fitted into the free end of arm G, and held in place by set-screw or otherwise. G is a curved caster-arm, and is of such form that, when the colter is secured in place thereto, the plane of the colter shall cut the center of the journal of the caster-arm. The journal portion of the arm is provided with a series of prominences, as seen at *i* in Figs. 2 and 5. The spaces between the prominences *i* are of such size as to receive the lower flange *f'* on arm *c* of bracket B, and are so arranged that the arm may be raised or lowered by changing it into the different spaces between the prominences *i* for the purpose of changing the working depth of the colter. The transverse section of prominences *i* is of V-form, as seen at *i*, Fig. 4, and is for the purpose of limiting the vibratory movement of the colter. H is a box, the upper end of which is fitted to receive the cylindrical upper portion of caster-arm G. The lower portion of box H is cut away in the front side to receive the prominences *i* on arm G, and is of sufficient width to admit of the required vibratory movement of the colter D, which is limited by means of the prominences *i* against the sides of the lower portion of box H. The box H is of proper length to fit in between the flanges *f* and *f'*, and is held in place on bracket B by means of a screw eye-bolt, I, which encircles box H and is passed through slot *g* in bracket B, to which it is secured by screw-nut *k*. By this arrangement the colter may be set to or from the land for the purpose of bringing it in proper position with respect to the plow, the slot *g* permitting of such lateral adjustment.

In the construction of my rolling colter I have employed but one caster-arm, and in this instance have placed it on the land-side of the colter. The object of this arrangement is to prevent clogging and to enable the colter to clear itself of anything likely to clog it.

I am aware that the position of the colter-

shank relative to the plow-beam has been heretofore adjusted by moving the bracket and screw-staple upon the beam, but in the construction heretofore employed, an additional piece of metal is required, arranged on top of the beam to furnish a seat for the stirrup. This is objectionable, because this supplemental piece is liable to become displaced and even lost; and, further, because it is difficult to provide as wide a range of adjustment as is desirable.

It will be seen that as the box H is confined between the flanges *f f'* the shank is effectually held from vibrating about the eye-bolt I. Thus these flanges are made to serve a double purpose—that is, to adjust the height of the colter and to maintain it in a proper vertical position, and as they extend the entire length of arm *c* the colter-blade may be moved the

entire length of the slot *g*, and yet be held firmly in its place without any twisting strain upon the bolt I.

I claim as my invention—

1. The bracket B provided with the notches or flutings *a b*, in combination with the screw-staple C for attaching the colter to the plow-beam and adjusting it thereon, substantially as set forth.

2. The combination of bracket B, having the arm *c* provided with flanges *f f'* and slot *g*, the box H, the eye-bolt I, and the shank G provided with projections *i*, substantially as described.

CHESTER NASH.

Witnesses:

J. G. MANLOVE,  
JACOB BEHEL.