

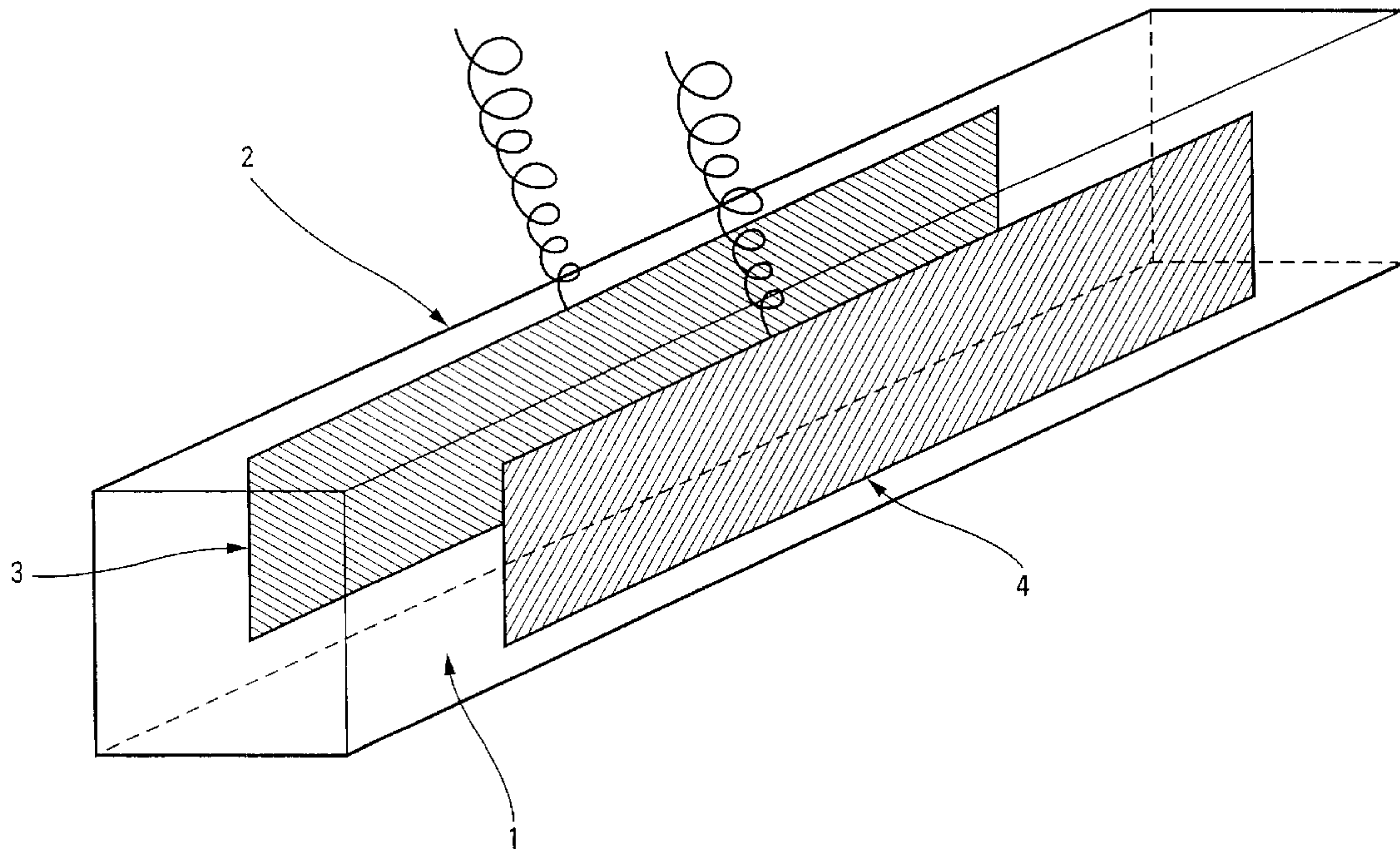

(86) Date de dépôt PCT/PCT Filing Date: 2001/06/20  
 (87) Date publication PCT/PCT Publication Date: 2001/12/27  
 (85) Entrée phase nationale/National Entry: 2002/12/23  
 (86) N° demande PCT/PCT Application No.: CA 2001/000917  
 (87) N° publication PCT/PCT Publication No.: 2001/097636  
 (30) Priorité/Priority: 2000/06/21 (0007948) FR

(51) Cl.Int.<sup>7</sup>/Int.Cl.<sup>7</sup> A23N 15/00  
 (71) Demandeur/Applicant:  
MCCAIN FOODS LIMITED, CA  
 (72) Inventeurs/Inventors:  
COUSIN, JEAN-FRANCOIS, FR;  
DESAILLY, FABRICE, FR;  
GOULLIEUX, ADELIN, FR;  
PAIN, JEAN-PIERRE, FR  
 (74) Agent: BERESKIN & PARR

(54) Titre : PROCEDE SERVANT A TRAITER DES LEGUMES ET DES FRUITS AVANT LEUR CUISSON  
 (54) Title: PROCESS FOR TREATING VEGETABLES AND FRUIT BEFORE COOKING



(57) **Abrégé/Abstract:**

A process for treating vegetables and fruit in order to reduce their resistance to cutting. Treatment involves the application of a high electric field directly to the vegetables and fruit, under such conditions that the resulting temperature increase for the vegetables and fruit is almost zero and at any rate, sufficiently low not to amount to a preheating step.

## (12) INTERNATIONAL APPLICATION PUBLISHED UNDER THE PATENT COOPERATION TREATY (PCT)

(19) World Intellectual Property Organization  
International Bureau(43) International Publication Date  
27 December 2001 (27.12.2001)

PCT

(10) International Publication Number  
**WO 01/97636 A1**(51) International Patent Classification<sup>7</sup>: **A23N 15/00**

(21) International Application Number: PCT/CA01/00917

(22) International Filing Date: 20 June 2001 (20.06.2001)

(25) Filing Language: English

(26) Publication Language: English

(30) Priority Data:  
0007948 21 June 2000 (21.06.2000) FR(71) Applicant (for all designated States except US): **MCCAIN ALIMENTAIRE SA** [FR/FR]; Parc d'Entreprises de la Motte du Bois, Boîte Postale 39, F-63440 Harnes (FR).(71) Applicant (for MG only): **MCCAIN FOODS LIMITED** [CA/CA]; 107 Main Street, P.O. Box 97, Florenceville, New Brunswick E7L 1B2 (CA).

(72) Inventors; and

(75) Inventors/Applicants (for US only): **COUSIN,****Jean-Francois** [FR/FR]; 78, rue Jacquemars Gielee, F-59800 Lille (FR). **DESAILLY, Fabrice** [FR/FR]; 19, rue Jeanne d'Arc, F-62580 Vimy (FR). **GOULLIEUX, Adeline** [FR/FR]; 92, rue des Etangs, F-60490 Mareuil la Motte (FR). **PAIN, Jean-Pierre** [FR/FR]; 36, rue Champion, F-60880 Le Meux (FR).(74) Agent: **BERESKIN & PARR**; 40 King Street West, 40th Floor, Toronto, Ontario M5H 3Y2 (CA).(81) Designated States (*national*): AE, AG, AL, AM, AT, AU, AZ, BA, BB, BG, BR, BY, BZ, CA, CH, CN, CO, CR, CU, CZ, DE, DK, DM, DZ, EE, ES, FI, GB, GD, GE, GH, GM, HR, HU, ID, IL, IN, IS, JP, KE, KG, KP, KR, KZ, LC, LK, LR, LS, LT, LU, LV, MA, MD, MG, MK, MN, MW, MX, MZ, NO, NZ, PL, PT, RO, RU, SD, SE, SG, SI, SK, SL, TJ, TM, TR, TT, TZ, UA, UG, US, UZ, VN, YU, ZA, ZW.(84) Designated States (*regional*): ARIPO patent (GH, GM, KE, LS, MW, MZ, SD, SL, SZ, TZ, UG, ZW), Eurasian patent (AM, AZ, BY, KG, KZ, MD, RU, TJ, TM), European patent (AT, BE, CH, CY, DE, DK, ES, FI, FR, GB, GR, IE, IT, LU, MC, NL, PT, SE, TR), OAPI patent (BF, BJ, CF, CG, CI, CM, GA, GN, GW, ML, MR, NE, SN, TD, TG).

[Continued on next page]

(54) Title: PROCESS FOR TREATING VEGETABLES AND FRUIT BEFORE COOKING

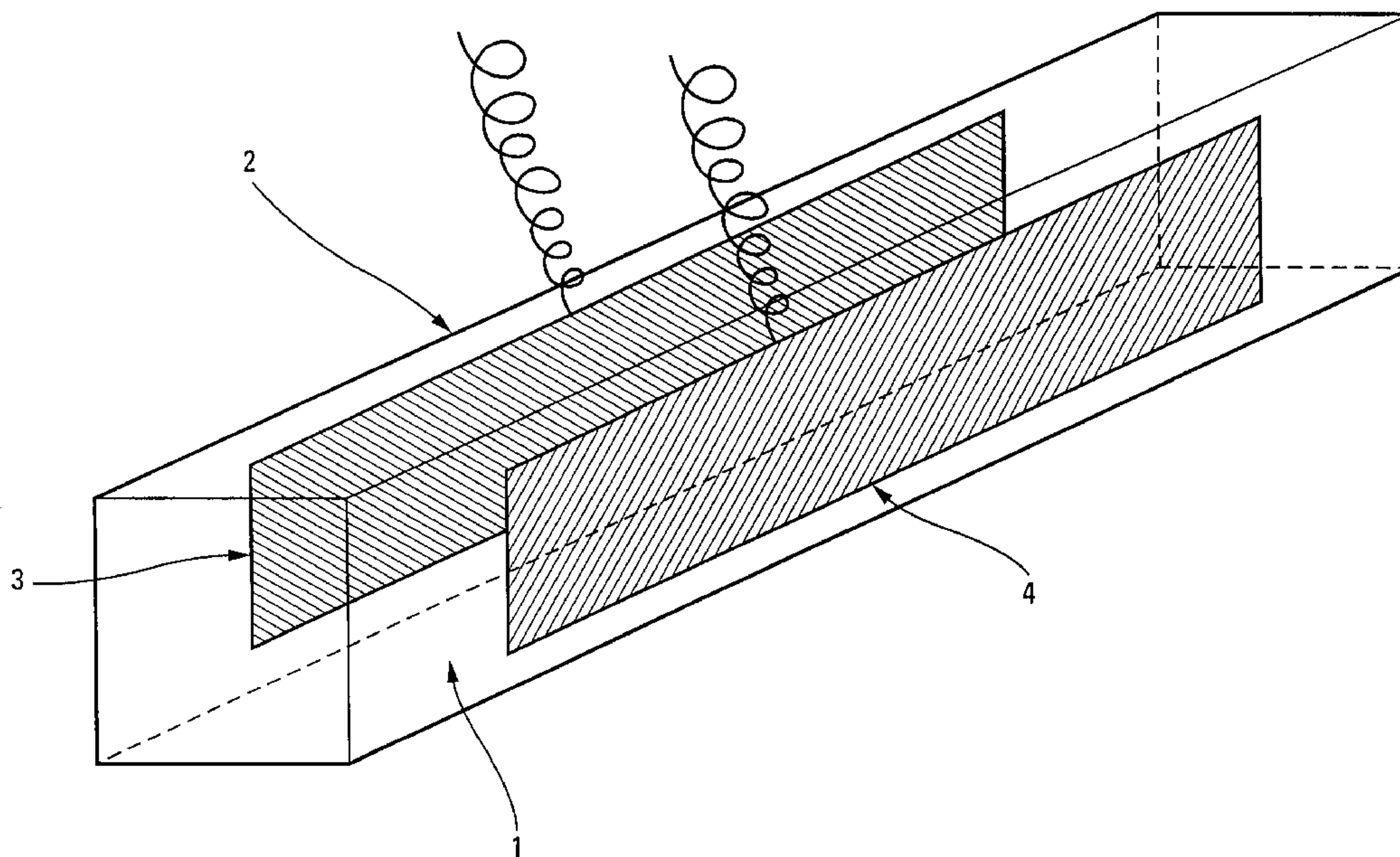

(57) Abstract: A process for treating vegetables and fruit in order to reduce their resistance to cutting. Treatment involves the application of a high electric field directly to the vegetables and fruit, under such conditions that the resulting temperature increase for the vegetables and fruit is almost zero and at any rate, sufficiently low not to amount to a preheating step.



WO 01/97636 A1

**WO 01/97636 A1**



**Published:**

- *with international search report*
- *before the expiration of the time limit for amending the claims and to be republished in the event of receipt of amendments*

*For two-letter codes and other abbreviations, refer to the "Guidance Notes on Codes and Abbreviations" appearing at the beginning of each regular issue of the PCT Gazette.*

- 1 -

**Title: PROCESS FOR TREATING VEGETABLES  
AND FRUIT BEFORE COOKING**

**FIELD OF THE INVENTION**

This invention concerns a process for treating tubers or roots,  
5 and more generally, vegetables and fruit such as potato, beet, turnip, carrot,  
salsify etc., before cooking.

**BACKGROUND OF THE INVENTION**

The invention applies particularly, but not exclusively, to the  
processing of potato tubers in the production of French fries.

10 Traditionally, the processing of vegetables includes a  
sequence of automated stages, during which vegetable tubers or roots are  
washed, peeled, size-sorted, cut, blanched, dried, possibly immersed in  
frying oils, frozen and packed. In the cutting stage, the vegetables are sliced  
into pieces, rings, or specifically as relates to French fries, into strips.

15 By way of example, the description below will particularity focus  
on the processing of potato tubers intended to make French fries, which is a  
preferred application of the process of this invention.

In order to ease tuber cutting, in other words, to reduce  
resistance to cutting, tubers traditionally are submitted to heat processing,  
20 which increases their flexibility. Typically, the tubers are directed toward a  
horizontal cylindrical tank, which is equipped with an endless screw, and  
contains water heated to a temperature of 40° to 60°C, where they are left for  
a period of 20 to 40 minutes. This process of preparing the tuber for cutting  
through heat processing, requires a major volume of water (from 25 to 30  
25 cubic meters of water for an automated line producing 15 tonnes of finished  
product per hour); this volume of water also has to be renewed, heated and  
maintained at the appropriate temperature.

This typical process has a number of drawbacks, including:

30 - At the surface of the tuber, a cooking ring is produced, due to  
starch gelatinization. This degrades the quality of the finished product in  
terms of texture and colour. The colour difference of the cook ring is viewed

- 2 -

as a defect to be eliminated, which results in a loss of material;

- Losses resulting from dissolution of tuber material in the water;

5 - Odors that may develop due to bacterial activity in the water and biological reactions;

- Processing which is not homogenous, since it operates through diffusion toward the inside of the tubers; a desired inside temperature is reached more rapidly in small tubers than in medium or large tubers.

10 Pre-treatment to reduce the tubers' resistance to cutting is necessary to ease the action of cutting tools, avoid twisting of the cut strips or a poor cut, as well as damage to the cutting knives. Inappropriate pre-treatment may result in a non-shear cut, and a "shattering" or crushing effect, that appears on the sliced strips as slits that are likely to make the  
15 strips fragile. Non-shear cutting means a major deterioration of the vegetable cells in the product, and therefore, large loss of material due to deteriorated cells. If a strip breaks below a minimal desired length, it will have to be eliminated or directed to a stream for by-product processing. Also, slits that appear during non-shear cutting will take on a brown  
20 discoloration during the cooking process; that harms the product appearance and increases oil absorption.

It would be desirable to submit tubers to treatment that will prepare them for cutting, and is efficient; in other words, a kind of treatment which avoids the "shattering" effect, while minimizing or even eliminating the  
25 drawbacks that were mentioned about traditional preheating.

To overcome the limitations of conventional methods of pretreating tubers, solutions involving electrical processes were investigated.

30 The application of pulsed electric fields is known in various areas of food product processing, for example food industry, specifically for sugar extraction from beets, or sterilization of food products.

U.S. Patent No. 3,997,678 (Vigerstrom) discloses a process

- 3 -

for processing potato tubers that are intended to be made into French fries. The process includes a blanching stage between the cutting and the immersion into frying oil, during which the strips are immersed in a bath of water and heated until sterilization is achieved by application of an electric field through electrodes immersed in the water. Traditionally, a blanching or precooking stage is included in processes for making tubers into fries. It is meant to reduce the temperature or the frying time, and consists in a preheating stage, in order to extract reducing sugars and inactivate enzymes. It is seen as a gelatinization of starch.

10 In contrast to the process that is disclosed in U.S. Patent No. 3,997,678, in which the application of an electric field occurs following cutting to heat and sterilize the product, the present invention focuses on treatment before cutting, to reduce the tuber resistance to cutting.

#### **SUMMARY OF THE INVENTION**

15 The invention provides a process that includes, as well known, a treatment stage for tubers or roots, and more generally, of vegetables and fruit in order to reduce their resistance to cutting, and thus reduce any loss of material during subsequent stages of the manufacturing process.

20 According to the invention, said stage consists in the application of a high electric field directly to vegetables and fruit, under such conditions that the resulting temperature increase for the vegetables and fruit is almost zero or at least sufficiently low as not to amount to a preheating stage. The application of a high electric field, such as is used for extracting sugar from beet and precooking fries, translates to vegetables and fruit, and particularly to potato tubers, with the effect of softening which is favourable to shear cutting during subsequent stages for transforming the tubers into fry strips. The process is found to be insensitive to tuber volume, whatever the size of the tuber, with the absence of any noticeable elevation of the tuber temperature; as such no cooking ring is formed that would lead to loss of material as occurs in the case of heat processing.

30 Tests have shown that, to obtain optimal cutting, tubers should be immersed in water and an electric field of 46 to 65 V/cm applied between

- 4 -

electrodes in the water, during a period of between 3 and 5 seconds.

#### **BRIEF DESCRIPTION OF DRAWING**

Other features and advantages of the invention will appear from the following description of a preferred embodiment which is given as  
5 a non-limiting example of a process according to the invention.

In the enclosed drawing, the single figure schematically represents an apparatus for carrying out the process.

#### **DESCRIPTION OF PREFERRED EMBODIMENT**

The following description relates to treatment of tubers or  
10 roots, specifically potato tubers intended for French fry manufacturing. However, it should be understood that all that follows may be generally applied to vegetables and fruit intended to be cut.

After being peeled, the tubers or roots are immersed in water 1  
in a tank 2 that is electrically isolated, and in which two electrodes 3, 4 made  
15 of titanium for instance, are immersed.

Appropriate systems such as wheels, screws, pipes or conveyors, may be used to continuously transport the tubers through the space between the electrodes.

The water conductivity is adjusted to be close to, and preferably  
20 below, the conductivity of tubers or roots, in order to limit any water heating. For instance, the water conductivity is set to be below about 0.020 S/m.

Preferably, treatment is performed at a low frequency, for instance, 50 or 60 Hz.

As an example, for potato tubers, an electric field between 45  
25 and 65 V/cm is applied to electrodes 3, 4 during periods of from 3 to 5 seconds.

For an electric field of 65 V/m applied for 5 seconds, the increase in temperature found for the water/tuber mixture is 5.6° C.

For an electric field of 45 V/cm applied for 3 seconds, this  
30 temperature increase is then only 1.6° C; in other words, the temperature increase is still sufficiently low that it produces neither any loss of material into the water, nor any cooking ring.

- 5 -

Precisely determining the voltage applied, and the application period, depends on the potato variety. The electrical processing has an impact on the colour, the texture and the taste of the finished product.

Comparative tests performed on different potato varieties (Bintje, Russet Burbank, Première varieties) have shown, following electrical processing, a quality of cutting which is at least equal to that obtained following traditional heat processing. Based on a sample strip which was heat processed, to which a sensorial score (tactile appreciation of the roughness of the strip edge) of 2.5 was given, tests with electric field pre-treatment gave a similar sensorial score of 3.5 for all varieties tested. It was also noted that the quality of cutting increased as the electric field increased.

These qualitative assessments were performed together with quantitative texture measurements, performed with a "texturometer"; a device that allows quantification of the tuber resistance to slicing. Results showed that the energy that is necessary to slice tubers which have been electrically processed is similar to the energy necessary to slice heat processed tubers.

Also, it was found that the energy at slicing decreased with an increase in electric field.

This definitely proves the efficiency of an electric field, which is applied under the conditions of the invention.

In addition to guaranteeing a shear cut, electrical processing according to the invention has several advantages, including:

- The consumption of a reduced volume of water (renewed at a lower rate), since there is no need to maintain a given temperature, and since the material, not being cooked, and therefore no longer has a tendency to dissolve in the water;
- A very short processing period (3 to 5 seconds, compared to the 20 to 40 minutes that are necessary for heat processing);
- Homogenous processing in volume, whatever the tuber size;
- Substantial energy savings. The energy consumed during

- 6 -

heat processing is about 40 Wh/kg, whereas energy consumed during electrical processing is about 6 Wh/kg;

- Electrical treatment before cutting increases enzymatic inactivation performed during blanching.

5           Electrical treatment also helps reduce the blanching time before frying, and thereby loss of material (hydrocarbons and starch) dissolved in the water because of precooking performed during the blanching stage.

10           Obviously, the invention is not limited to the embodiment described, and many modifications may be made, while keeping within this invention.

15           In particular, while the above example concerns the processing of potato tubers for French fry manufacturing, it would be easy for a skilled person to experimentally determine optimal operating conditions for processing other tubers or roots, or more generally, other vegetables or fruits, and specifically, to choose a processing period associated with an electric field of a given intensity.

20           Preferably, the electric field should be between 30 and 75 V/cm approximately, and the processing period between 1 and 10 seconds approximately.

          This invention is not limited to the use of an aqueous environment, and is workable with any liquid or fluid which conducts electricity to help create an electric field in accordance with the present invention.

- 7 -

**WE CLAIM:**

1. A process for treating vegetables and fruit before cooking in order to reduce their resistance to cutting, characterized by the application of a high electric field directly to the vegetables and/or fruit under conditions  
5 such that the resulting increase in the temperature of the vegetables and/or fruit is almost zero or at least sufficiently low as to not amount to a preheating step.
2. A process as claimed in claim 1, characterized in that the electric field is applied through titanium electrodes that are immersed in  
10 water in a tank containing the vegetables and/or fruit.
3. A process as claimed in claim 1 or 2, characterized in that an electric field of 45 to 65 V/cm is applied during a period between 3 and 5 seconds.
4. A process as claimed in and one of claims 1 to 3,  
15 characterized in that, during application of the electric field, the vegetables and/or fruit are immersed in water having a conductivity that is below or equal to the conductivity of the vegetables and/or fruit.
5. A process as claimed in claim 4, characterized in that the conductivity of the water is below 0.020 S/m.
- 20 6. A process as claimed in any one of claims 1 to 5, characterized in that the process is applied to processing of potatoes prior to cutting the potatoes into strips for the purpose of producing French fries.

