



(51) **International Patent Classification:**
G09F 9/30 (2006.01) *F16C 11/04* (2006.01)
G06F 1/16 (2006.01)

(21) **International Application Number:**
PCT/KR2020/000374

(22) **International Filing Date:**
09 January 2020 (09.01.2020)

(25) **Filing Language:** English

(26) **Publication Language:** English

(30) **Priority Data:**
62/799,705 31 January 2019 (31.01.2019) US
10-2019-0049318 26 April 2019 (26.04.2019) KR

(71) **Applicant:** LG ELECTRONICS INC. [KR/KR]; 128, Yeoui-daero, Yeongdeungpo-gu, Seoul 07336 (KR).

(72) **Inventor:** CHA, Youngdo; IP Center, LG Electronics Inc., 19, Yangjae-daero 11-gil, Seocho-gu, Seoul 06772 (KR).

(74) **Agent:** PARK, Jang-Won; 2nd-3rd Fl., 566, Gangnam-daero, Gangnam-Gu, Seoul 06044 (KR).

(81) **Designated States** (unless otherwise indicated, for every kind of national protection available): AE, AG, AL, AM, AO, AT, AU, AZ, BA, BB, BG, BH, BN, BR, BW, BY, BZ, CA, CH, CL, CN, CO, CR, CU, CZ, DE, DJ, DK, DM, DO, DZ, EC, EE, EG, ES, FI, GB, GD, GE, GH, GM, GT, HN, HR, HU, ID, IL, IN, IR, IS, JO, JP, KE, KG, KH, KN, KP, KW, KZ, LA, LC, LK, LR, LS, LU, LY, MA, MD, ME, MG, MK, MN, MW, MX, MY, MZ, NA, NG, NI, NO, NZ, OM, PA, PE, PG, PH, PL, PT, QA, RO, RS, RU, RW, SA, SC, SD, SE, SG, SK, SL, ST, SV, SY, TH, TJ, TM, TN, TR, TT, TZ, UA, UG, US, UZ, VC, VN, WS, ZA, ZM, ZW.

(84) **Designated States** (unless otherwise indicated, for every kind of regional protection available): ARIPO (BW, GH,

(54) **Title:** FLEXIBLE DISPLAY DEVICE

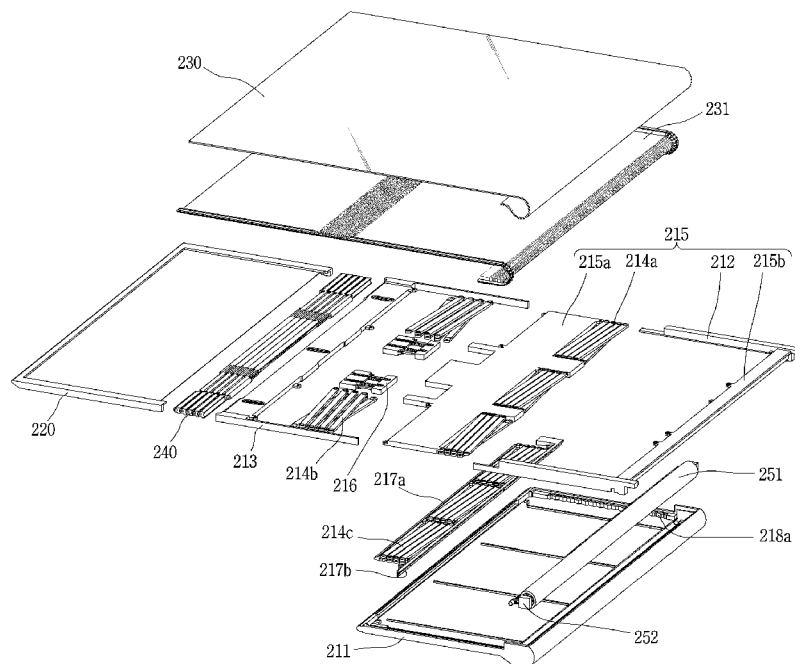

(57) **Abstract:** A flexible display device includes: a first body having a plurality of parts connected to each other so as to be relatively moveable; a second body connected to the first body so as to be relatively rotatable; a flexible display unit formed to be folded and unfolded, and arranged on a front surface of the first and second bodies; and a rear plate coupled to a rear surface of the flexible display unit, and formed to be transformed together with the flexible display unit, wherein the rear plate is formed so that at least part thereof is wound in the first body, and the wound part of the rear plate is moved to the front surface of the first body by interworking with a relative movement of the plurality of parts, so that an exposed region of the flexible display unit is increased.



WO 2020/159095 A1

GM, KE, LR, LS, MW, MZ, NA, RW, SD, SL, ST, SZ, TZ,
UG, ZM, ZW), Eurasian (AM, AZ, BY, KG, KZ, RU, TJ,
TM), European (AL, AT, BE, BG, CH, CY, CZ, DE, DK,
EE, ES, FI, FR, GB, GR, HR, HU, IE, IS, IT, LT, LU, LV,
MC, MK, MT, NL, NO, PL, PT, RO, RS, SE, SI, SK, SM,
TR), OAPI (BF, BJ, CF, CG, CI, CM, GA, GN, GQ, GW,
KM, ML, MR, NE, SN, TD, TG).

Published:

— *with international search report (Art. 21(3))*

Description

Title of Invention: FLEXIBLE DISPLAY DEVICE

Technical Field

- [1] The present disclosure relates to a flexible display device, and particularly, to a flexible display device having a flexible display unit which is transformable by an external force.

Background Art

- [2] A portable electronic device (hereinafter, a mobile terminal) such as a communication terminal, a multimedia device, a portable computer, a game machine and a capturing device is provided with a display for displaying video information. The mobile terminal may have a folding structure to be folded into a smaller size, for convenience of portability. In such an electronic device, two bodies are connected to each other by a folding structure (e.g., a hinge unit).
- [3] Since the conventional display has no folding structure, it was impossible to implement a structure to arrange a display on two bodies connected to each other in a foldable manner. Therefore, it was impossible to apply a large screen to an electronic device of a folding structure.
- [4] However, as a flexible display which can be bent is being developed recently, research to apply such a flexible display to a mobile terminal is actively ongoing. In this case, since the flexible display is arranged on two bodies through a folding structure, a large screen may be implemented.
- [5] In a flexible display device, even if a flexible display is transformable into a folding state and an unfolding state by using a hinge unit, there is a limitation in extending a screen. Further, when the folding state is converted into the unfolding state or vice versa, an unnecessary load may be applied to the flexible display, or a folding in a reverse direction may be performed to cause inconvenience to a user.
- [6] Therefore, there is provided a mechanism of a flexible display device, capable of having a display long in a vertical direction in a folding state for utilization as a smart phone, having a screen ratio of about 1:1 in an unfolding state, and extending a screen exposed to the outside by an extending operation. Here, considered is a method for providing a smooth movement of a flexible display unit for implementation of various states.

Disclosure of Invention

Technical Problem

- [7] Therefore, an aspect of the detailed description is to provide a flexible display device which can perform folding, unfolding and extending, and more particularly, to a rolling

type of new mechanism for extending of a flexible display unit.

- [8] Another aspect of the detailed description is to provide a structure of a flexible display device which can perform a smooth movement by folding, unfolding and extending.

Solution to Problem

- [9] To achieve these and other advantages and in accordance with the purpose of this specification, as embodied and broadly described herein, a flexible display device has a structure that one body has one side to which another body is rotatably connected, and another side where a flexible display unit is rolled. The flexible display unit may be supported by a rear plate, and may have a structure to be transformable together with the rear plate.
- [10] More specifically, the flexible display device includes: a first body having a plurality of parts connected to each other so as to be relatively moveable; a second body connected to the first body so as to be relatively rotatable; a flexible display unit formed to be folded and unfolded, and arranged on a front surface of the first and second bodies; and a rear plate coupled to a rear surface of the flexible display unit, and formed to be transformed together with the flexible display unit.
- [11] The rear plate is formed so that at least part thereof is wound in the first body, and the wound part of the rear plate is moved to the front surface of the first body by interworking with a relative movement of the plurality of parts, so that an exposed region of the flexible display unit is increased.
- [12] In an embodiment of the present disclosure, the rear plate may include: mounting portions extended in one direction, and recessed to couple the rear surface of the flexible display unit; transformation portions having a plurality of extension bars arranged in parallel so as to cross the mounting portions, and formed to be transformed in correspondence to the flexible display unit; and a bending supporting portion extended towards the outside from both sides of the mounting portions.
- [13] In another embodiment, a bonding member may be formed between an upper surface of the rear plate and a bottom surface of the flexible display unit.
- [14] In another embodiment, the bending supporting portion may be formed to be bent by being concaved downward, and a metallic supporting member may be coupled to a bottom surface of the bending supporting portion. The metallic supporting member may maintain a parallel state when the flexible display unit is unfolded, and may maintain a bent state when the flexible display unit is folded or rolled.
- [15] In another embodiment, a molding member having a concavo-convex shape may be coupled to an upper surface of the bending supporting portion.
- [16] In another embodiment, the transformation portions may include: a first trans-

formation portion having a plurality of extension bars arranged in parallel and spaced from each other with predetermined intervals, so as to be transformed in correspondence to folding and unfolding of the flexible display unit; and a second transformation portion spaced from the first transformation portion, and having a plurality of extension bars arranged in parallel so as to be transformed in correspondence to the wound part of the rear plate.

- [17] In another embodiment, the flexible display unit may be changed into an extending state from an unfolding state, by being unfolded by a relative movement of the plurality of parts.
- [18] In another embodiment, in a folding state of the flexible display unit, the second body may be arranged to cover a rear surface of the first body, and the flexible display unit may be exposed to the outside.
- [19] In another embodiment, a hinge unit for connecting the first body and the second body to each other so as to be relatively rotatable may be installed at one side of the first body, and bearing portions for winding at least part of the flexible display unit thereon may be installed at another side of the first body.
- [20] In another embodiment, the hinge unit may be provided with a plurality of hinge segments sequentially arranged in one direction, and the hinge segments may be arranged to enclose a side surface of the first body in a folding state of the flexible display unit.
- [21] In another embodiment, the bearing portions may include: a first bearing configured to wind the flexible display unit thereon; and a second bearing spaced from the first bearing, and configured to support the flexible display unit in the first body. A groove for inserting the second bearing may be formed at the first body, and the second bearing may perform a rotation and a linear movement in the groove.
- [22] In another embodiment, the plurality of parts of the first body may include: a first part; a second part coupled to the first part; and a third part installed so as to be slidable between the first part and the second part.
- [23] In another embodiment, the flexible display device further includes a first extension unit arranged at the first body. The first extension unit may include a plurality of links rotatably connected to each other; and a first fixing housing and a second fixing housing arranged in a state that the plurality of links are interposed therebetween. And the first fixing housing may be coupled to the flexible display unit and may be formed to be moveable in the first body, and the second fixing housing may be fixed to the first body.
- [24] In another embodiment, the flexible display device may further include a second extension unit arranged to be overlapped with the first extension unit, having one side connected to the first part, and having another side connected to one end of the flexible

display unit. And the second extension unit may include a third fixing housing and a fourth fixing housing arranged in a state that a plurality of links are interposed therebetween.

[25] In another embodiment, a flexible display device includes: a first body having a plurality of parts connected to each other so as to be relatively moveable; a second body connected to one side of the first body by a hinge unit, so as to be relatively rotatable with respect to the first body; a flexible display unit formed to be folded and rolled, and arranged on a front surface of the first and second bodies; a rear plate coupled to a rear surface of the flexible display unit, and formed to be transformed together with the flexible display unit; and bearing portions installed at another side of the first body, and configured to wind at least part of the flexible display unit thereon. The flexible display unit may be changed into an extending state from an unfolding state, by being unfolded together with the rear plate by a relative movement of the plurality of parts.

[26] In another embodiment, the bearing portions may include: a first bearing configured to wind the flexible display unit thereon; and a second bearing spaced from the first bearing, and configured to support the flexible display unit in the first body.

Advantageous Effects of Invention

[27] Effects of the present disclosure obtained by the aforementioned solution means are as follows.

[28] Firstly, the flexible display unit having three screen sizes of a folding state, an unfolding state and an extending state may be implemented through a structure of folding, unfolding and rolling of the flexible display unit. In this case, a user may be provided with three modes of a mobile phone, a note, and a tablet having an extended screen.

[29] Secondly, through an interworking structure of the bodies, a connection operation of a folding state, an unfolding state and an extending state may be implemented in a compact space. Further, through a movement of the rear plate coupled to the rear surface of the flexible display unit, a smooth operation of the flexible display unit (rolling, unrolling and extending) can be performed. Also, the flexible display unit can be smoothly supported, and an unnecessary load can be prevented.

Brief Description of Drawings

[30] FIG. 1 is a block diagram for explaining a mobile terminal according to the present disclosure.

[31] FIG. 2A is a perspective view of a flexible display device, which shows an outer folding state.

[32] FIG. 2B is a perspective view of the flexible display device, which shows an

unfolding state.

[33] FIG. 2C is a perspective view of the flexible display device, which shows an extending state of the flexible display device and thus an extendedly-varied state of a flexible display unit.

[34] FIGS. 3A, 3B and 3C are conceptual views showing implementable states of the flexible display device.

[35] FIG. 4 is a planar view showing an inner form of the flexible display device having the flexible display unit removed therefrom.

[36] FIG. 5 is a disassembled perspective view of the flexible display device.

[37] FIG. 6 is a perspective view showing a rear plate.

[38] FIG. 7A is a partially enlarged view showing a metallic supporting member coupled to the rear plate.

[39] FIG. 7B is a sectional view showing the flexible display unit coupled to the rear plate.

[40] FIG. 8 is an enlarged sectional view showing an arrangement structure of the rear plate and the flexible display unit, in a first state where the flexible display unit has been unfolded.

[41] FIG. 9 is an enlarged sectional view showing an arrangement structure of the rear plate and the flexible display unit, in a second state where the flexible display unit has been folded.

[42] FIG. 10 is a sectional view showing a state that the flexible display unit is rolled by a first bearing.

[43] FIG. 11 is a perspective view showing a rear plate according to another embodiment of the present disclosure.

[44] FIG. 12A is a partially enlarged view showing a molding member coupled to the rear plate.

[45] FIG. 12B is a sectional view showing a lamination structure of a flexible display unit coupled to the rear plate.

Mode for the Invention

[46] Description will now be given in detail according to exemplary embodiments disclosed herein, with reference to the accompanying drawings. For the sake of brief description with reference to the drawings, the same or equivalent components may be provided with the same or similar reference numbers, and description thereof will not be repeated. In general, a suffix such as "module" and "unit" may be used to refer to elements or components. Use of such a suffix herein is merely intended to facilitate description of the specification, and the suffix itself is not intended to give any special meaning or function. In describing the present disclosure, if a detailed explanation for

a related known function or construction is considered to unnecessarily divert the gist of the present disclosure, such explanation has been omitted but would be understood by those skilled in the art. The accompanying drawings are used to help easily understand the technical idea of the present disclosure and it should be understood that the idea of the present disclosure is not limited by the accompanying drawings. The idea of the present disclosure should be construed to extend to any alterations, equivalents and substitutes besides the accompanying drawings.

[47] It will be understood that although the terms first, second, etc. may be used herein to describe various elements, these elements should not be limited by these terms. These terms are generally only used to distinguish one element from another.

[48] It will be understood that when an element is referred to as being "connected with" another element, the element can be connected with the another element or intervening elements may also be present. In contrast, when an element is referred to as being "directly connected with" another element, there are no intervening elements present.

[49] A singular representation may include a plural representation unless it represents a definitely different meaning from the context.

[50] Terms such as "include" or "has" are used herein and should be understood that they are intended to indicate an existence of several components, functions or steps, disclosed in the specification, and it is also understood that greater or fewer components, functions, or steps may likewise be utilized.

[51] Display devices presented herein may be implemented using a variety of different types of terminals. Examples of such devices include cellular phones, smart phones, user equipment, laptop computers, digital broadcast terminals, personal digital assistants (PDAs), portable multimedia players (PMPs), navigators, portable computers (PCs), slate PCs, tablet PCs, ultra books, wearable devices (for example, smart watches, smart glasses, head mounted displays (HMDs)), and the like.

[52] By way of non-limiting example only, further description will be made with reference to particular types of mobile terminals. However, such teachings apply equally to other types of terminals, such as those types noted above. In addition, these teachings may also be applied to stationary terminals such as digital TV, desktop computers, and the like. Hereinafter, for convenience of description, the mobile terminal will be described as one example of a flexible display device.

[53] FIG. 1 is a block diagram of a mobile terminal in accordance with the present disclosure.

[54] The mobile terminal 100 may be shown having components such as a wireless communication unit 110, an input unit 120, a sensing unit 140, an output unit 150, an interface unit 160, a memory 170, a controller (or control unit) 180, and a power supply unit 190. It is understood that implementing all of the illustrated components is

not a requirement. Greater or fewer components may alternatively be implemented.

[55] In more detail, the wireless communication unit 110 may typically include one or more modules which permit communications such as wireless communications between the mobile terminal 100 and a wireless communication system, communications between the mobile terminal 100 and another mobile terminal, or communications between the mobile terminal 100 and an external server. Further, the wireless communication unit 110 may typically include one or more modules which connect the mobile terminal 100 to one or more networks.

[56] The wireless communication unit 110 may include one or more of a broadcast receiving module 111, a mobile communication module 112, a wireless Internet module 113, a short-range communication module 114, and a location information module 115.

[57] The input unit 120 may include a camera 121 or an image input unit for obtaining images or video, a microphone 122, which is one type of audio input device for inputting an audio signal, and a user input unit 123 (for example, a touch key, a mechanical key, and the like) for allowing a user to input information. Data (for example, audio, video, image, and the like) may be obtained by the input unit 120 and may be analyzed and processed according to user commands.

[58] The sensing unit 140 may typically be implemented using one or more sensors configured to sense internal information of the mobile terminal, the surrounding environment of the mobile terminal, user information, and the like. For example, the sensing unit 140 may include at least one of a proximity sensor 141, an illumination sensor 142, a touch sensor, an acceleration sensor, a magnetic sensor, a G-sensor, a gyroscope sensor, a motion sensor, an RGB sensor, an infrared (IR) sensor, a finger scan sensor, a ultrasonic sensor, an optical sensor (for example, camera 121), a microphone 122, a battery gauge, an environment sensor (for example, a barometer, a hygrometer, a thermometer, a radiation detection sensor, a thermal sensor, and a gas sensor, among others), and a chemical sensor (for example, an electronic nose, a health care sensor, a biometric sensor, and the like). The mobile terminal disclosed herein may be configured to utilize information obtained from one or more sensors of the sensing unit 140, and combinations thereof.

[59] The output unit 150 may typically be configured to output various types of information, such as audio, video, tactile output, and the like. The output unit 150 may be shown having at least one of a display unit 151, an audio output module 152, a haptic module 153, and an optical output module 154. The display unit 151 may have an inter-layered structure or an integrated structure with a touch sensor in order to implement a touch screen. The touch screen may function as the user input unit 123 which provides an input interface between the mobile terminal 100 and the user and si-

multaneously provide an output interface between the mobile terminal 100 and a user.

[60] The interface unit 160 serves as an interface with various types of external devices that are coupled to the mobile terminal 100. The interface unit 160, for example, may include any of wired or wireless ports, external power supply ports, wired or wireless data ports, memory card ports, ports for connecting a device having an identification module, audio input/output (I/O) ports, video I/O ports, earphone ports, and the like. In some cases, the mobile terminal 100 may perform assorted control functions associated with a connected external device, in response to the external device being connected to the interface unit 160.

[61] The memory 170 is typically implemented to store data to support various functions or features of the mobile terminal 100. For instance, the memory 170 may be configured to store application programs executed in the mobile terminal 100, data or instructions for operations of the mobile terminal 100, and the like. Some of these application programs may be downloaded from an external server via wireless communication. Other application programs may be installed within the mobile terminal 100 at time of manufacturing or shipping, which is typically the case for basic functions of the mobile terminal 100 (for example, receiving a call, placing a call, receiving a message, sending a message, and the like). Application programs may be stored in the memory 170, installed in the mobile terminal 100, and executed by the controller 180 to perform an operation (or function) for the mobile terminal 100.

[62] The controller 180 typically functions to control an overall operation of the mobile terminal 100, in addition to the operations associated with the application programs. The controller 180 may provide or process information or functions appropriate for a user by processing signals, data, information and the like, which are input or output by the aforementioned various components, or activating application programs stored in the memory 170.

[63] Also, the controller 180 may control at least some of the components illustrated in FIG. 1, to execute an application program that have been stored in the memory 170. In addition, the controller 180 may control at least two of those components included in the mobile terminal 100 to activate the application program.

[64] The power supply unit 190 may be configured to receive external power or provide internal power in order to supply appropriate power required for operating elements and components included in the mobile terminal 100. The power supply unit 190 may include a battery, and the battery may be configured to be embedded in the terminal body, or configured to be detachable from the terminal body.

[65] At least part of the components may cooperatively operate to implement an operation, a control or a control method of a mobile terminal according to various embodiments disclosed herein. Also, the operation, the control or the control method of

the mobile terminal may be implemented on the mobile terminal by an activation of at least one application program stored in the memory 170.

- [66] Hereinafter, description will be given in more detail of the aforementioned components with reference to FIG. 1, prior to describing various embodiments implemented through the mobile terminal 100.
- [67] First, regarding the wireless communication unit 110, the broadcast receiving module 111 is typically configured to receive a broadcast signal and/or broadcast associated information from an external broadcast managing entity via a broadcast channel. The broadcast channel may include a satellite channel, a terrestrial channel, or both. In some embodiments, two or more broadcast receiving modules may be utilized to facilitate simultaneous reception of two or more broadcast channels, or to support switching among broadcast channels.
- [68] The broadcast management server may be a server that generates and transmits a broadcast signal and/or broadcast associated information or a server that receives a previously generated broadcast signal and/or broadcast associated information and transmits the same to a terminal. The broadcast signal may include a TV broadcast signal, a radio broadcast signal, a data broadcast signal, and the like. Also, the broadcast signal may further include a broadcast signal in a form that a TV or radio broadcast signal is combined with a data broadcast signal.
- [69] The broadcast signal may be encrypted by at least one of technical standards (or broadcasting methods, e.g., ISO, IEC, DVB, ATSC, etc.) for transmitting and receiving a digital broadcast signal. The broadcast receiving module 111 may receive the digital broadcast signal using a method suitable for a technical standard selected from those technical standards.
- [70] Examples of the broadcast associated information may include information associated with a broadcast channel, a broadcast program, a broadcast service provider, and the like. The broadcast associated information may be provided via a mobile communication network. In this case, the broadcast associated information may be received by the mobile communication module 112.
- [71] The broadcast associated information may be implemented in various formats. For instance, broadcast associated information may include Electronic Program Guide (EPG) of Digital Multimedia Broadcasting (DMB), Electronic Service Guide (ESG) of Digital Video Broadcast-Handheld (DVB-H), and the like. The broadcast signal and/or the broadcast related information received through the broadcast receiving module 111 may be stored in the memory 160.
- [72] The mobile communication module 112 can transmit and/or receive wireless signals to and from one or more network entities. Typical examples of a network entity include a base station, an external mobile terminal, a server, and the like. Such network

entities form part of a mobile communication network, which is constructed according to technical standards or communication methods for mobile communications (for example, Global System for Mobile Communication (GSM), Code Division Multi Access (CDMA), CDMA2000 (Code Division Multi Access 2000), EV-DO (Enhanced Voice-Data Optimized or Enhanced Voice-Data Only), Wideband CDMA (WCDMA), High Speed Downlink Packet access (HSDPA), HSUPA (High Speed Uplink Packet Access), Long Term Evolution (LTE) , LTE-A (Long Term Evolution-Advanced), and the like).

[73] The wireless signal may include various types of data depending on a voice call signal, a video call signal, or a text / multimedia message transmission / reception.

[74] The wireless Internet module 113 refers to a module for wireless Internet access. This module may be internally or externally coupled to the mobile terminal 100. The wireless Internet module 113 may transmit and/or receive wireless signals via communication networks according to wireless Internet technologies.

[75] Examples of such wireless Internet access include Wireless LAN (WLAN), Wireless Fidelity (Wi-Fi), Wi-Fi Direct, Digital Living Network Alliance (DLNA), Wireless Broadband (WiBro), Worldwide Interoperability for Microwave Access (WiMAX), High Speed Downlink Packet Access (HSDPA), High Speed Uplink Packet Access (HSUPA), Long Term Evolution (LTE), LTE-advanced (LTE-A) and the like. The wireless Internet module 113 may transmit/receive data according to one or more of such wireless Internet technologies, and other Internet technologies as well.

[76] When the wireless Internet access is implemented according to, for example, WiBro, HSDPA, HSUPA, GSM, CDMA, WCDMA, LTE, LTE-A and the like, as part of a mobile communication network, the wireless Internet module 113 performs such wireless Internet access. As such, the Internet module 113 may cooperate with, or function as, the mobile communication module 112.

[77] The short-range communication module 114 is configured to facilitate short-range communications. Suitable technologies for implementing such short-range communications include BLUETOOTH™, Radio Frequency Identification (RFID), Infrared Data Association (IrDA), Ultra-WideBand (UWB), ZigBee, Near Field Communication (NFC), Wireless-Fidelity (Wi-Fi), Wi-Fi Direct, Wireless USB (Wireless Universal Serial Bus), and the like. The short-range communication module 114 in general supports wireless communications between the mobile terminal 100 and a wireless communication system, communications between the mobile terminal 100 and another mobile terminal 100, or communications between the mobile terminal and a network where another mobile terminal 100 (or an external server) is located, via wireless area networks. One example of the wireless area networks is a wireless personal area networks.

- [78] Here, another mobile terminal (which may be configured similarly to mobile terminal 100) may be a wearable device, for example, a smart watch, a smart glass or a head mounted display (HMD), which is able to exchange data with the mobile terminal 100 (or otherwise cooperate with the mobile terminal 100). The short-range communication module 114 may sense or recognize the wearable device, and permit communication between the wearable device and the mobile terminal 100. In addition, when the sensed wearable device is a device which is authenticated to communicate with the mobile terminal 100, the controller 180, for example, may cause transmission of at least part of data processed in the mobile terminal 100 to the wearable device via the short-range communication module 114. Hence, a user of the wearable device may use the data processed in the mobile terminal 100 on the wearable device. For example, when a call is received in the mobile terminal 100, the user may answer the call using the wearable device. Also, when a message is received in the mobile terminal 100, the user can check the received message using the wearable device.
- [79] The location information module 115 is generally configured to detect, calculate, derive or otherwise identify a position (or current position) of the mobile terminal. As an example, the location information module 115 includes a Global Position System (GPS) module, a Wi-Fi module, or both. For example, when the mobile terminal uses a GPS module, a position of the mobile terminal may be acquired using a signal sent from a GPS satellite. As another example, when the mobile terminal uses the Wi-Fi module, a position of the mobile terminal can be acquired based on information related to a wireless access point (AP) which transmits or receives a wireless signal to or from the Wi-Fi module. If desired, the location information module 115 may alternatively or additionally function with any of the other modules of the wireless communication unit 110 to obtain data related to the position of the mobile terminal. The location information module 115 is a module used for acquiring the position (or the current position) and may not be limited to a module for directly calculating or acquiring the position of the mobile terminal.
- [80] Examples of such inputs include audio, image, video, data, and user input. Image and video input is often obtained using one or more cameras 121. Such cameras 121 may process image frames of still pictures or video obtained by image sensors in a video or image capture mode. The processed image frames can be displayed on the display unit 151 or stored in memory 170. Meanwhile, the cameras 121 may be arranged in a matrix configuration to permit a plurality of images having various angles or focal points to be input to the mobile terminal 100. Also, the cameras 121 may be located in a stereoscopic arrangement to acquire left and right images for implementing a stereoscopic image.
- [81] The microphone 122 processes an external audio signal into electric audio (sound)

data. The processed audio data can be processed in various manners according to a function being executed in the mobile terminal 100. If desired, the microphone 122 may include assorted noise removing algorithms to remove unwanted noise generated in the course of receiving the external audio signal.

[82] The user input unit 123 is a component that permits input by a user. Such user input may enable the controller 180 to control operation of the mobile terminal 100. The user input unit 123 may include one or more of a mechanical input element (for example, a mechanical key, a button located on a front and/or rear surface or a side surface of the mobile terminal 100, a dome switch, a jog wheel, a jog switch, and the like), or a touch-sensitive input element, among others. As one example, the touch-sensitive input element may be a virtual key, a soft key or a visual key, which is displayed on a touch screen through software processing, or a touch key which is located on the mobile terminal at a location that is other than the touch screen. On the other hand, the virtual key or the visual key may be displayed on the touch screen in various shapes, for example, graphic, text, icon, video, or a combination thereof.

[83] The sensing unit 140 is generally configured to sense one or more of internal information of the mobile terminal, surrounding environment information of the mobile terminal, user information, or the like, and generate a corresponding sensing signal. The controller 180 generally cooperates with the sensing unit 140 to control operations of the mobile terminal 100 or execute data processing, a function or an operation associated with an application program installed in the mobile terminal based on the sensing signal. The sensing unit 140 may be implemented using any of a variety of sensors, some of which will now be described in more detail.

[84] The proximity sensor 141 refers to a sensor to sense presence or absence of an object approaching a surface, or an object located near a surface, by using an electromagnetic field, infrared rays, or the like without a mechanical contact. The proximity sensor 141 may be arranged at an inner area of the mobile terminal covered by the touch screen, or near the touch screen.

[85] The proximity sensor 141, for example, may include any of a transmissive type photoelectric sensor, a direct reflective type photoelectric sensor, a mirror reflective type photoelectric sensor, a high-frequency oscillation proximity sensor, a capacitance type proximity sensor, a magnetic type proximity sensor, an infrared rays proximity sensor, and the like. When the touch screen is implemented as a capacitance type, the proximity sensor 141 can sense proximity of a pointer relative to the touch screen by changes of an electromagnetic field, which is responsive to an approach of an object with conductivity. In this case, the touch screen (touch sensor) may also be categorized as a proximity sensor.

[86] The term "proximity touch" will often be referred to herein to denote the scenario in

which a pointer is positioned to be proximate to the touch screen without contacting the touch screen. The term "contact touch" will often be referred to herein to denote the scenario in which a pointer makes physical contact with the touch screen. For the position corresponding to the proximity touch of the pointer relative to the touch screen, such position will correspond to a position where the pointer is perpendicular to the touch screen. The proximity sensor 141 may sense proximity touch, and proximity touch patterns (for example, distance, direction, speed, time, position, moving status, and the like). In general, controller 180 processes data corresponding to proximity touches and proximity touch patterns sensed by the proximity sensor 141, and cause output of visual information on the touch screen. In addition, the controller 180 can control the mobile terminal 100 to execute different operations or process different data (or information) according to whether a touch with respect to a point on the touch screen is either a proximity touch or a contact touch.

[87] A touch sensor senses a touch (or a touch input) applied to the touch screen (or the display unit 151) using any of a variety of touch methods. Examples of such touch methods include a resistive type, a capacitive type, an infrared type, and a magnetic field type, among others.

[88] As one example, the touch sensor may be configured to convert changes of pressure applied to a specific part of the display unit 151, or convert capacitance occurring at a specific part of the display unit 151, into electric input signals. The touch sensor may also be configured to sense not only a touched position and a touched area, but also touch pressure and/or touch capacitance. A touch object is generally used to apply a touch input to the touch sensor. Examples of typical touch objects include a finger, a touch pen, a stylus pen, a pointer, or the like.

[89] When a touch input is sensed by a touch sensor, corresponding signals may be transmitted to a touch controller. The touch controller may process the received signals, and then transmit corresponding data to the controller 180. Accordingly, the controller 180 may sense which area of the display unit 151 has been touched. Here, the touch controller may be a component separate from the controller 180, the controller 180, and combinations thereof.

[90] Meanwhile, the controller 180 may execute the same or different controls according to a type of touch object that touches the touch screen or a touch key provided in addition to the touch screen. Whether to execute the same or different control according to the object which provides a touch input may be decided based on a current operating state of the mobile terminal 100 or a currently executed application program, for example.

[91] The touch sensor and the proximity sensor may be implemented individually, or in combination, to sense various types of touches. Such touches include a short (or tap)

touch, a long touch, a multi-touch, a drag touch, a flick touch, a pinch-in touch, a pinch-out touch, a swipe touch, a hovering touch, and the like.

- [92] If desired, an ultrasonic sensor may be implemented to recognize location information relating to a touch object using ultrasonic waves. The controller 180, for example, may calculate a position of a wave generation source based on information sensed by an illumination sensor and a plurality of ultrasonic sensors. Since light is much faster than ultrasonic waves, the time for which the light reaches the optical sensor is much shorter than the time for which the ultrasonic wave reaches the ultrasonic sensor. The position of the wave generation source may be calculated using this fact. For instance, the position of the wave generation source may be calculated using the time difference from the time that the ultrasonic wave reaches the sensor based on the light as a reference signal.
- [93] The camera 121, which has been depicted as a component of the input unit 120, typically includes at least one a camera sensor (CCD, CMOS etc.), a photo sensor (or image sensors), and a laser sensor.
- [94] Implementing the camera 121 with a laser sensor may allow detection of a touch of a physical object with respect to a 3D stereoscopic image. The photo sensor may be laminated on, or overlapped with, the display device. The photo sensor may be configured to scan movement of the physical object in proximity to the touch screen. In more detail, the photo sensor may include photo diodes and transistors (TRs) at rows and columns to scan content received at the photo sensor using an electrical signal which changes according to the quantity of applied light. Namely, the photo sensor may calculate the coordinates of the physical object according to variation of light to thus obtain location information of the physical object.
- [95] The display unit 151 is generally configured to output information processed in the mobile terminal 100. For example, the display unit 151 may display execution screen information of an application program executing at the mobile terminal 100 or user interface (UI) and graphic user interface (GUI) information in response to the execution screen information.
- [96] Also, the display unit 151 may be implemented as a stereoscopic display unit for displaying stereoscopic images.
- [97] A typical stereoscopic display unit may employ a stereoscopic display scheme such as a stereoscopic scheme (a glass scheme), an auto-stereoscopic scheme (glassless scheme), a projection scheme (holographic scheme), or the like.
- [98] The audio output module 152 may receive audio data from the wireless communication unit 110 or output audio data stored in the memory 170 during modes such as a signal reception mode, a call mode, a record mode, a voice recognition mode, a broadcast reception mode, and the like. The audio output module 152 can provide

audible output related to a particular function (e.g., a call signal reception sound, a message reception sound, etc.) performed by the mobile terminal 100. The audio output module 152 may also be implemented as a receiver, a speaker, a buzzer, or the like.

[99] A haptic module 153 can be configured to generate various tactile effects that a user feels, perceives, or otherwise experiences. A typical example of a tactile effect generated by the haptic module 153 is vibration. The strength, pattern and the like of the vibration generated by the haptic module 153 may be controlled by user selection or setting by the controller 180. For example, the haptic module 153 may output different vibrations in a combining manner or a sequential manner.

[100] Besides vibration, the haptic module 153 can generate various other tactile effects, including an effect by stimulation such as a pin arrangement vertically moving to contact skin, a spray force or suction force of air through a jet orifice or a suction opening, a touch to the skin, a contact of an electrode, electrostatic force, an effect by reproducing the sense of cold and warmth using an element that can absorb or generate heat, and the like.

[101] The haptic module 153 can also be implemented to allow the user to feel a tactile effect through a muscle sensation such as the user's fingers or arm, as well as transferring the tactile effect through direct contact. Two or more haptic modules 153 may be provided according to the particular configuration of the mobile terminal 100.

[102] An optical output module 154 can output a signal for indicating an event generation using light of a light source. Examples of events generated in the mobile terminal 100 may include message reception, call signal reception, a missed call, an alarm, a schedule notice, an email reception, information reception through an application, and the like.

[103] A signal output by the optical output module 154 may be implemented in such a manner that the mobile terminal emits monochromatic light or light with a plurality of colors. The signal output may be terminated as the mobile terminal senses that a user has checked the generated event, for example.

[104] The interface unit 160 serves as an interface for external devices to be connected with the mobile terminal 100. For example, the interface unit 160 can receive data transmitted from an external device, receive power to transfer to elements and components within the mobile terminal 100, or transmit internal data of the mobile terminal 100 to such external device. The interface unit 160 may include wired or wireless headset ports, external power supply ports, wired or wireless data ports, memory card ports, ports for connecting a device having an identification module, audio input/output (I/O) ports, video I/O ports, earphone ports, or the like.

[105] The identification module may be a chip that stores various information for authen-

ticating authority of using the mobile terminal 100 and may include a user identity module (UIM), a subscriber identity module (SIM), a universal subscriber identity module (USIM), and the like. In addition, the device having the identification module (also referred to herein as an "identifying device") may take the form of a smart card. Accordingly, the identifying device can be connected with the terminal 100 via the interface unit 160.

[106] When the mobile terminal 100 is connected with an external cradle, the interface unit 160 can serve as a passage to allow power from the cradle to be supplied to the mobile terminal 100 or may serve as a passage to allow various command signals input by the user from the cradle to be transferred to the mobile terminal therethrough. Various command signals or power input from the cradle may operate as signals for recognizing that the mobile terminal is properly mounted on the cradle.

[107] The memory 170 can store programs to support operations of the controller 180 and store input/output data (for example, phonebook, messages, still images, videos, etc.). The memory 170 may store data related to various patterns of vibrations and audio which are output in response to touch inputs on the touch screen.

[108] The memory 170 may include one or more types of storage mediums including a flash memory type, a hard disk type, a solid state disk (SSD) type, a silicon disk drive (SDD) type, a multimedia card micro type, a card-type memory (e.g., SD or DX memory, etc.), a Random Access Memory (RAM), a Static Random Access Memory (SRAM), a Read-Only Memory (ROM), an Electrically Erasable Programmable Read-Only Memory (EEPROM), a Programmable Read-Only memory (PROM), a magnetic memory, a magnetic disk, an optical disk, and the like. The mobile terminal 100 may also be operated in relation to a network storage device that performs the storage function of the memory 170 over a network, such as the Internet.

[109] The controller 180 may typically control operations relating to application programs and the general operations of the mobile terminal 100. For example, the controller 180 may set or release a lock state for restricting a user from inputting a control command with respect to applications when a status of the mobile terminal meets a preset condition.

[110] The controller 180 can also perform the controlling and processing associated with voice calls, data communications, video calls, and the like, or perform pattern recognition processing to recognize a handwriting input or a picture drawing input performed on the touch screen as characters or images, respectively. In addition, the controller 180 can control one or a combination of those components in order to implement various exemplary embodiments disclosed herein.

[111] The power supply unit 190 receives external power or provides internal power and supply the appropriate power required for operating respective elements and

components included in the wearable device 100 under the control of the controller 180. The power supply unit 190 may include a battery, which is typically rechargeable or be detachably coupled to the terminal body for charging.

[112] The power supply unit 190 may include a connection port. The connection port may be configured as one example of the interface unit 160 to which an external charger for supplying power to recharge the battery is electrically connected.

[113] As another example, the power supply unit 190 may be configured to recharge the battery in a wireless manner without use of the connection port. In this example, the power supply unit 190 can receive power, transferred from an external wireless power transmitter, using at least one of an inductive coupling method which is based on magnetic induction or a magnetic resonance coupling method which is based on electromagnetic resonance.

[114] Various embodiments described herein may be implemented in a computer-readable medium, a machine-readable medium, or similar medium using, for example, software, hardware, or any combination thereof.

[115] The display unit 151 is generally configured to output information processed in the mobile terminal 100. For example, the display unit 151 may display execution screen information of an application program executing at the mobile terminal 100 or user interface (UI) and graphic user interface (GUI) information in response to the execution screen information.

[116] The display module 151 may include at least one of a liquid crystal display (LCD), a thin film transistor-LCD (TFT LCD), an organic light-emitting diode (OLED), a flexible display, a three-dimensional (3D) display and an e-ink display.

[117] The display unit 151 may be implemented using two display devices, according to the configuration type thereof. For instance, a plurality of the display units 151 may be arranged on one side, either spaced apart from each other, or these devices may be integrated, or these devices may be arranged on different surfaces.

[118] The display unit 151 may include a touch sensor that senses a touch with respect to the display unit 151 so as to receive a control command in a touch manner. Accordingly, when a touch is applied to the display unit 151, the touch sensor may sense the touch, and a controller 180 may generate a control command corresponding to the touch. Contents input in the touch manner may be characters, numbers, instructions in various modes, or a menu item that can be specified.

[119] The microphone 122 may be configured to receive the user's voice, other sounds, and the like. The microphone 122 may be provided at a plurality of places, and configured to receive stereo sounds.

[120] The interface unit 160 may serve as a path allowing the mobile terminal 100 to interface with external devices. For example, the interface unit 160 may be at least one

of a connection terminal for connecting to another device (for example, an earphone, an external speaker, or the like), a port for near field communication (for example, an Infrared Data Association (IrDA) port, a Bluetooth port, a wireless LAN port, and the like), or a power supply terminal for supplying power to the mobile terminal 100. The interface unit 160 may be implemented in the form of a socket for accommodating an external card, such as Subscriber Identification Module (SIM), User Identity Module (UIM), or a memory card for information storage.

- [121] At least one antenna for wireless communication may be disposed on the terminal body. The antenna may be embedded in the terminal body or formed in the case. For example, an antenna which configures a part of the broadcast receiving module 111 (see FIG. 1) may be retractable into the terminal body. Alternatively, an antenna may be formed in a form of film to be attached onto an inner surface of the housing or a case including a conductive material may serve as an antenna.
- [122] The terminal body is provided with a power supply unit 190 (see FIG. 1) for supplying power to the mobile terminal 100. The power supply unit 190 may include a battery 191 which is mounted in the terminal body or detachably coupled to an outside of the terminal body.
- [123] The battery 191 may receive power via a power cable connected to the interface unit 160. Also, the battery 191 may be (re)chargeable in a wireless manner using a wireless charger. The wireless charging may be implemented by magnetic induction or electromagnetic resonance.
- [124] An accessory for protecting an appearance or assisting or extending the functions of the mobile terminal 100 may further be provided on the mobile terminal 100. As one example of the accessory, a cover or pouch for covering or accommodating at least one surface of the mobile terminal 100 may be provided. The cover or pouch may cooperate with the display unit 151 to extend the function of the mobile terminal 100. Another example of the accessory may be a touch pen for assisting or extending a touch input onto a touch screen.
- [125] FIG. 2A is a perspective view of a flexible display device 200, which shows an outer folding state. FIG. 2B is a perspective view of the flexible display device 200, which shows an unfolding state. And FIG. 2C is a perspective view of the flexible display device 200, which shows an extending state of the flexible display device and thus an extendedly-varied state of a flexible display unit.
- [126] The flexible display device 200 may be understood as a type of the aforementioned mobile terminal, and the device may be referred to as a flexible display device for convenience in this specification.
- [127] The flexible display device 200 according to the present disclosure may be provided with a flexible display unit 230 which is formed to be transformable by an external

force. And a rear plate 231 is coupled to a rear surface of the flexible display unit 230. Accordingly, the flexible display unit 230 may be transformable smoothly.

[128] Here, the transformation may mean at least one of curve, bending, folding, twist and rolling of a display module. Such a transformable display module may be referred to as a 'flexible display'. Here, the flexible display unit 230 may include a general flexible display, e-paper and a combination thereof.

[129] A general flexible display means a display having characteristics of the conventional flat display, manufactured on a thin and flexible substrate which can be curved, bent, folded, twisted and rolled like paper, and thus having a light and strong characteristic.

[130] Further, electronic paper is a display technology using a general ink characteristic, which may be different from the conventional flat display in that reflected light is used. The electronic paper may change information by using twist balls, or by using an electrophoresis using capsules.

[131] The flexible display device 200 according to the present disclosure may have a state that the flexible display unit 230 is transformed by an external force (e.g., a folded state having a finite curvature radius, hereinafter, will be referred to as first state, refer to FIG. 2A), and a state that the flexible display unit 230 is not transformed (e.g., a state having an infinite curvature radius, hereinafter, will be referred to as second state, refer to FIGS. 2B and 2C). In the second state, a display region of the flexible display unit 230 is planar.

[132] Also, the flexible display device 200 according to the present disclosure may have a state that the flexible display unit 230 is additionally extended by an additional external force (e.g., an extended state having an infinite curvature radius, hereinafter, will be referred to as third state).

[133] As shown, information displayed in the first state may include visual information outputted on a curved surface. Such visual information is implemented as light-emitting of sub pixels arranged in the form of matrices is controlled independently. The sub pixels mean a minimum unit to implement a single color.

[134] The flexible display unit 230 may have a curved state, not a flat state in the first state (e.g., a curved state up and down or right and left, a folded state). In this case, if an external force is applied to the flexible display unit 230, the flexible display unit 230 may be transformed to a flat state (or a less curved state) or a more curved state.

[135] The flexible display unit 230 may implement a flexible touch screen (not shown) by combining with a touch sensor. When a touch input is applied to the flexible touch screen (not shown), the controller 180 (refer to FIG. 1) may perform a control corresponding to the touch input. The flexible touch screen may be configured to sense a touch input not only in the first state, but also in the second and third states.

[136] The flexible display device 200 according to a modification of the present disclosure

may be provided with a transformation sensing means for sensing a transformation of the flexible display unit 230. The transformation sensing means may be included in the sensing unit 140 (refer to FIG. 1).

[137] The transformation sensing means may be provided at the flexible display unit 230 or bodies 210, 220, thereby sensing information related to a transformation of the flexible display unit 230. The information related to a transformation may be a transformation direction, a transformation degree, a transformation position, a transformation time of the flexible display unit 230, and an acceleration to restore the transformed flexible display unit 230. Also, the information may be various information which can be sensed due to bending of the flexible display unit 230.

[138] The controller 180 (refer to FIG. 1) may change information displayed on the flexible display unit 230, or may generate a control signal for controlling a function of the flexible display device 200, based on the information related to a transformation of the flexible display unit 230 sensed by the transformation sensing means .

[139] A state transformation of the flexible display unit 230 is not limited to a transformation by an external force. For instance, when the flexible display unit 230 is in the first state, the first state may be changed into the second state or the third state by a command of a user or an application.

[140] The flexible display device 200 according to an embodiment of the present disclosure may be provided with a case (for instance, a frame, a cover, etc.) for forming appearance. The case may include the first body 210 and the second body 220, and various types of electronic components may be arranged in the first body 210 and the second body 220.

[141] The flexible display device 200 may be provided on one surface of each of the first and second bodies 210, 220 rotatably connected to each other, and may be transformed by a movement of the first and second bodies 210, 220.

[142] As shown in FIG. 2A, the flexible display unit 230 may be folded along the second body 220 in the first state. The flexible display unit 230 may be folded to cover an upper surface of the first body 210 together with the second body 220 in an outwardly-exposed state, and a rear surface of the first body 210 may be overlapped with the second body 220.

[143] More specifically, the first body 210 of the flexible display device 200 supports one region of the flexible display unit 230, and the second body 220 of the flexible display device 200 supports another region (the remaining region) of the flexible display unit 230. Here, a plurality of electronic components for driving the flexible display device 200 may be mounted to at least one of the first and second bodies 210, 220.

[144] The first and second bodies 210, 220 may perform a relative rotation in a connected state to each other, with a predetermined angle. And the flexible display unit 230 may

be in a folded state (first state) to overlap at least one region thereof, by being bent.

[145] As shown in FIG. 2B, the flexible display device 200 may have an unfolding state (second state) that the flexible display unit 230 is unfolded. In this case, the first and second bodies 210, 220 may be arranged on the same plane in parallel, and the flexible display unit 230 may be in an unfolded state by the first and second bodies 210, 220. This may allow a user to perform various tasks such as an electronic book and a web surfing.

[146] As shown in FIG. 2C, in the second state, the flexible display unit 230 may implement the third state that the flexible display unit 230 exposed to the outside is extended as the flexible display unit 230 wound in the first body 210 is withdrawn out. In this case, a user may use a large screen more conveniently by utilizing the extended flexible display unit 230.

[147] FIGS. 3A~3C are conceptual views showing implementable states in the flexible display device 200.

[148] The rear plate 231 may be coupled to a rear surface of the flexible display unit 230. The rear plate 231 can implement the first state shown in FIG. 3A, the second state shown in FIG. 3B, and the third state shown in FIG. 3C, by being transformed together with the flexible display unit 230.

[149] As shown in FIG. 3A, the flexible display device 200 may implement the first state that rear surfaces of the first and second bodies 210, 220 face each other, as one side of the flexible display unit 230 is folded together with the rear plate 231. Here, the outer side surface of the flexible display unit 230 maintains an outwardly-exposed state, and is arranged outside each of the first and second bodies 210, 220.

[150] In the first state of the flexible display device 200, the first and second bodies 210, 220 are overlapped with each other, and a space between one region and another region of the flexible display unit 230 may be bent with a curved surface. The curved surface of the flexible display unit 230 enables the rear plate 231 to be bent by a hinge unit 240.

[151] As shown in FIG. 3A, since the second body 220 is folded to the flexible display unit 230 with respect to the first body 210, the hinge unit 240 is configured to enclose one side surface of the first body 210 at the time of a folding operation.

[152] Here, one side surface of the first body 210 may have a thickness greater than that of the second body 220, and the first body 210 encloses one side surface of the second body 220 together with the flexible display unit 230. As a result, an outer folding may be implemented.

[153] That is, the flexible display device 200 may implement an outer folding structure as the rear plate 231 is transformed together with the flexible display unit 230. Under the outer folding structure, the flexible display unit 230 is in an outward-exposed state at

the time of a folding operation, and covers an outer surface of the first body 210 together with the second body 220.

[154] As shown in FIG. 3B, the flexible display device 200 may have an unfolding state (second state) that the flexible display unit 230 is unfolded. In the second state, the first and second bodies 210, 220 may be arranged on the same plane in parallel.

[155] While the first state of the flexible display device 200 is changed into the second state, an angle formed by one region and another region of the flexible display unit 230 may be variable. This can be implemented by a transformation of the rear plate 231.

[156] The rear plate 231 may be folded by a transformation of a first transformation portion 235a. And a region of the flexible display unit 230, corresponding to the first transformation portion 235a is gradually folded as an angle of the first transformation portion 235a is changed. This can allow the first state to be converted into the second state.

[157] As shown in FIG. 3C, in the second state that the flexible display unit 230 is unfolded, the flexible display device 200 may implement the third state that a region of the flexible display unit 230 wound in the first body 210 is moved to the front surface of the first body 210 as the length of the first body 210 is increased, and thus an extended display region may be obtained.

[158] More specifically, the rear plate 231 may be formed so that at least part thereof is wound in the first body 210. The wound part of the rear plate 231 may be moved to the front surface of the first body 210 by interworking with a relative movement of a plurality of parts, so that an exposed region of the flexible display unit 230 is increased.

[159] A second transformation portion 235b of the rear plate 231 may be transformed so that at least part thereof is wound in the first body 210. As a result, at least part of the flexible display unit 230 may be wound in the first body 210. If the length of the first body 210 is increased, a part of the flexible display unit 230 wound in the first body 210 is moved to the front surface of the first body 210. This can allow an extended display region to be obtained.

[160] That is, as shown in FIGS. 3A~3C, the flexible display device 200 may implement the first state that the flexible display unit 230 is folded, the second state that the flexible display unit 230 is unfolded, and the third state that an outwardly-exposed area of the flexible display unit 230 is extended. Accordingly, a user may utilize a mobile terminal which is used at ordinary times, as a note or a tablet more conveniently.

[161] That is, the flexible display device 200 according to the present disclosure can implement the flexible display unit 230 having three screen sizes of a folding state, an unfolding state and an extending state, and can provide a user with three modes of a phone, a note and a tablet. Further, through an interworking structure of the bodies

210, 220, a connection operation of a folding state, an unfolding state and an extending state may be implemented in a compact space.

[162] FIG. 4 is a planar view showing an inner form of the flexible display device 200 having the flexible display unit 230 removed therefrom, and FIG. 5 is a disassembled perspective view of the flexible display device 200.

[163] The flexible display device 200 may further include the first body 210, the second body 220, the hinge unit 240, the flexible display unit 230 and the rear plate 231. The flexible display unit 230 coupled to the rear plate 231 may implement a first state (folding), a second state (unrolling), and a third state (extending) by movement of the first body 210 and the second body 220.

[164] The rear plate 231 may be coupled to a rear surface of the flexible display unit 230. The rear plate 231 serves to support the flexible display unit 230, and is transformable together with the flexible display unit 230 according to each state when the flexible display device 200 implements folding, unrolling, and extending.

[165] A detailed structure of the rear plate 231 will be explained later.

[166] The first body 210 may be provided with a plurality of parts connected to each other so as to be relatively moveable with respect to each other. The first body 210 may include a first part 211, a second part 212 and a third part 213.

[167] The first part 211 is a part which can be held by a user's hand, and may form appearance of a rear surface of the first body 210.

[168] A predetermined recess extended in a lengthwise direction may be formed at one end of the first part 211, and a bearing portion may be installed at the recess.

[169] The bearing portion may mean a first bearing 251, and the first bearing 251 may be inserted into the recess so as to wind at least part of the flexible display unit 230 thereon together with the rear plate 231. The part of the rear plate 231 and the flexible display unit 230, wound along the first bearing 251, may be moved in a direction parallel to an upper surface of the first part 211, in a spaced state from the upper surface of the first part 211 by a predetermined gap.

[170] The second part 212 has its one side coupled to the first part 211, and may be formed to have a '□' shape. Each edge of the second part 212 may be fixed by being coupled to the first part 211.

[171] A second fixing housing 215b may be formed at one side of the second part 212, and one side of a first link 214b which will be explained later may be fixed to the second fixing housing 215b. The second fixing housing 215b covers the first bearing 251 inserted into the first part 211, thereby preventing separation of the first bearing 251.

[172] In the second part 212, may be installed a first link 214a formed to be extended and contracted according to whether the flexible display unit 230 is extended or not, and a first fixing housing 215a for fixing one side of the first link 214a.

- [173] The third part 213 is formed to have a '⊔' shape, and may be installed to face the second part 212. The hinge unit 240 may be coupled to one side of the third part 213, and the third part 213 may be rotatably coupled to the second body 220 by the hinge unit 240.
- [174] The third part 213 may be installed so as to be slidable between the first part 211 and the second part 212. The third part 213 may slide in a state that both sides thereof extended towards the second part 212 are supported by one side of the first part 211.
- [175] The first body 210 may include extension units 215, 219 for implementing a third state (extending) of the flexible display unit 230.
- [176] The extension units 215, 219 serve to implement an extending state that at least part of the flexible display unit 230, wound in the first body 210, has its area exposed to the outside increased, by movement of the third part 213. The extension units 215, 219 may be formed to be extended by an extended length of the rear plate 231 and the flexible display unit 230, as the third part 213 performs a sliding between the first part 211 and the second part 212.
- [177] That is, since an entire length of the first body 210 is increased by an extended length of the rear plate 231 and the flexible display unit 230 through the extension units 215, 219, the third state of the flexible display device 200 may be stably implemented.
- [178] The extension units may include the first extension unit 215 and the second extension unit 219. The first extension unit 215 is arranged at the first body 210, and may include a plurality of first links 214a rotatably connected to each other, and the first fixing housing 215a and the second fixing housing 215b arranged in a state that the plurality of first links 214a are interposed therebetween.
- [179] If a user pulls one side of the second body 220 or the third part 213 by his or her hand in order to increase an outwardly-exposed area of the flexible display unit 230, the rear plate 231 and a wound part of the flexible display unit 230 are unrolled, and the first fixing housing 215a may move along a moving direction of the flexible display unit 230, by the length of the unrolled flexible display unit 230. In this case, the plurality of first links 214a installed between the first fixing housing 215a and the second fixing housing 215b become unfolded by a relative rotation, thereby covering the extended length of the flexible display unit 230.
- [180] The first fixing housing 215a may be coupled to the flexible display unit 230, and may be formed to be moveable in the first body 210. The second fixing housing 215b may be fixed to the first body 210. Accordingly, the first extension unit 215 may be extended by an extended length of the flexible display unit 230 in the third state.
- [181] The second extension unit 219 may include a third fixing housing 217a, a fourth fixing housing 217b, and a third link 214c positioned between the third fixing housing 217a and the fourth fixing housing 217b.

- [182] The second extension unit 219 and the first extension unit 215 have an up-down arrangement structure, and may be arranged to be overlapped with each other. One side of the second extension unit 219 may be connected to the first part 211, and another side thereof may be connected to one end of the flexible display unit 230.
- [183] The second body 220 may have a structure to be relatively rotatable with respect to the first body 210, through the hinge unit 240. Under the structure, the flexible display device 200 may implement a folding state.
- [184] The flexible display unit 230 coupled to the rear plate 231 is coupled to one surface of the second body 220, thereby allowing a user to perform a folding operation or an unfolding operation with holding the second body 220.
- [185] When the flexible display unit 230 is in a folding state (the first state), the second body 220 may be arranged to cover the rear surface of the first body 210. In this case, the flexible display unit 230 is exposed to the outside.
- [186] The hinge unit 240 for connecting the first body 210 and the second body 220 to each other so as to be relatively rotatable is arranged at one side of the first body 210. As the hinge unit 240 is operated, the second body 220 may be folded with respect to the first body 210.
- [187] The hinge unit 240 is provided with a plurality of hinge segments 241 sequentially arranged in one direction, and the hinge segments 241 may be arranged to enclose the side surface of the first body 210 in a folding state of the flexible display unit 230.
- [188] The flexible display unit 230 may be formed to have a flexible characteristic for both of folding and rolling. The flexible display unit 230 is arranged on the front surface of the first body 210 and the second body 220, and can be transformed in correspondence to folding, unfolding and extending by movement of the first body 210 and the second body 220.
- [189] The flexible display unit 230 may be formed so that at least part thereof is wound in the first body 210. The wound part of the flexible display unit 230 may be moved to the front surface of the first body 210 by interworking with a relative movement of a plurality of parts, so that an exposed region of the flexible display unit 230 is increased.
- [190] That is, the flexible display unit 230 has a structure to be changed into an extending state from an unfolding state, by being unfolded by a relative movement of the plurality of parts. This can provide a user with a larger screen.
- [191] As shown in FIG. 4, a main PCB 261 for processing a signal for driving of the flexible display device 200, a battery 264 for power supply, and a driver IC 231 for operating the flexible display unit 230 may be positioned so as to be overlapped with the second body.
- [192] A hardware component 263 having various types of sensors and a camera module

may be positioned so as to be overlapped with the first fixing housing 215a, and a sub PCB 262 may be positioned so as to be overlapped with the third part 213.

- [193] FIG. 6 is a perspective view showing the rear plate 231. FIG. 7A is a partially enlarged view showing a metallic supporting member coupled to the rear plate 231. And FIG. 7B is a sectional view showing the flexible display unit 230 coupled to the rear plate 231.
- [194] The rear plate 231 is coupled to the rear surface of the flexible display unit 230, and may be formed to be transformable together with the flexible display unit 230.
- [195] The rear plate 231 may be formed to be folded or unfolded for the first and second states of the flexible display device 200. And the rear plate 231 may be formed to be wound in the first body 210 at least partially. Here, the wound part of the rear plate 231 may be moved to the front surface of the first body 210 by interworking with a relative movement of a plurality of parts, so that an exposed region of the flexible display unit 230 is increased.
- [196] The rear plate 231 may be formed of a stainless (STS) thin film.
- [197] The rear plate 231 may be provided with mounting portions 233a, 233a' for coupling the rear surface of the flexible display unit 230, and transformation portions 235a, 235b which are transformable in correspondence to a movement of the flexible display unit 230. Also, the rear plate 231 may be provided with a bending supporting portion 234 extended towards the outside from both sides of the mounting portions.
- [198] The mounting portions 233a, 233a' for forming a bottom surface of the rear plate 231 may be formed to be extended in one direction in the shape of a thin plate, and may be concaved with a predetermined depth so as to mount the rear surface of the flexible display unit 230.
- [199] The rear plate 231 may be provided with a bending supporting portion 234 extended towards the outside from both sides of the mounting portions. The bending supporting portion 234 may be formed to be bent by being concaved downward, and may have a bendable structure in one direction. For instance, the bending supporting portion 234 may be formed to have a U-shape.
- [200] As shown in FIG. 7A, a metallic supporting member 236 may be coupled to a bottom surface of the bending supporting portion 234.
- [201] The metallic supporting member 236 may be extended in one direction along the bottom surface of the bending supporting portion 234 of the rear plate 231. The metallic supporting member 236 may be formed to have a shape corresponding to the bottom surface of the bending supporting portion 234.
- [202] The metallic supporting member 236 may maintain a parallel state when the flexible display unit 230 is unfolded, and may maintain a bent state when the flexible display unit 230 is folded or rolled. The metallic supporting member 236 may be formed of

titanium specially processed to maintain a bent state by transformation.

[203] Transformation portions 235a, 235b serve to transform the flexible display unit 230. The transformation portions 235a, 235b may be formed to be transformable for implementation of folding, unfolding, rolling or unrolling of the flexible display unit 230.

[204] The transformation portions 235a, 235b may include the first transformation portion 235a and the second transformation portion 235b. The first transformation portion 235a and the second transformation portion 235b may be formed on different regions of the rear plate 231, and can be transformed so that the rear plate 231 is folded or the rear plate 231 is wound along the first bearing 251.

[205] As shown in the enlarged part of FIG. 6, each of the first transformation portion 235a and the second transformation portion 235b may have a structure that a plurality of extension bars 235c which connect both sides of the bending supporting portion 234 are arranged in parallel. In case of folding or rolling the flexible display unit 230, the plurality of extension bars 235c can be bent as the neighboring extension bars 235c are relatively moved. Accordingly, folding and rolling of the rear plate 231 can be implemented, and folding and rolling of the flexible display unit 230 coupled to the rear plate 231 can be implemented.

[206] Alternatively, the first transformation portion 235a and the second transformation portion 235b may be formed by cutting a selected region of the rear plate 231 by predetermined intervals. In this case, may be obtained the same effect as the plurality of extension bars 235c which connect the bending supporting portions 234 positioned at both sides of the mounting portion 233a.

[207] Here, the first transformation portion 235a may be formed at a position corresponding to the hinge unit 240, and may be bent for implementation of the first state that the flexible display unit 230 is folded.

[208] The second transformation portion 235b may be positioned in the first body 210, and can be bent for rolling of the flexible display unit 230 along a rotation body 251b of the first bearing 251.

[209] As shown in FIG. 7B, the flexible display unit 230 can be coupled to the mounting portions 233a, 233a' by a bonding member 237.

[210] The bonding member 237 may be installed between the flexible display unit 230 and the mounting portions 233a, 233a' of the rear plate 231.

[211] The bonding member 237 may serve to firmly couple a lower surface of the flexible display unit 230 to a bottom surface of the rear plate 231. The bonding member 237 may be formed of a flexible material so that a gap of the flexible display unit 230 is prevented, the gap occurring when there is a space between the rear plate 231 and the flexible display unit 230, as the rear plate 231 and the flexible display unit 230 are transformed.

- [212] Further, the bonding member 237 serves to restrict damage of the flexible display unit 230 by an external force, by preventing a stress occurring between the rear plate 231 and the flexible display unit 230.
- [213] For instance, the bonding member 237 may be formed of elastomer resin having an elastic force, by using synthetic epoxy resin, etc. Accordingly, the bonding member 237 serves to firmly couple the flexible display unit 230 and the rear plate 231 to each other, and to smoothly transform the rear plate 231 in correspondence to the flexible display unit 230 when the flexible display unit 230 is transformed by folding or rolling.
- [214] The mounting portions 233a, 233a' may be concaved to have a U-shape. The mounting portions 233a, 233a' may include a horizontal portion 233 having a flat shape so as to be coupled to the rear surface of the flexible display unit 230, and a vertical portion 232 upward extended from both ends of the horizontal portion 233 so as to cross the horizontal portion 233.
- [215] The flexible display unit 230 may be coupled onto the horizontal portion 233 of the mounting portions 233a, 233a' of the rear plate 231 by the bonding member 237.
- [216] Here, the flexible display unit 230 may be formed to have the same height as the vertical portion 232. In this case, since the flexible display unit 230 is formed to have the same height as the bending supporting portion 234, appearance exposed to the outside may be enhanced more.
- [217] FIG. 8 is an enlarged sectional view showing an arrangement structure of the rear plate 231 and the flexible display unit 230, in a first state where the flexible display unit 230 has been unfolded. And FIG. 9 is an enlarged sectional view showing an arrangement structure of the rear plate 231 and the flexible display unit 230, in a second state where the flexible display device 200 has been folded.
- [218] As aforementioned, the first and second bodies 210, 220 of the flexible display device 200 may be connected to each other by the hinge unit 240 so as to be relatively rotatable with respect to each other.
- [219] The hinge unit 240 serves to connect the first and second bodies 210, 220 to each other so as to be relatively rotatable with respect to each other, and may be arranged between the first and second bodies 210, 220. The flexible display unit 230 is arranged on one surface of the first and second bodies 210, 220, and can be folded and unfolded by the relative rotation.
- [220] The hinge unit 240 may include a plurality of hinge segments 241 sequentially arranged in one direction, and each of the hinge segments 241 may be arranged to enclose the side surface of the first body 210 in a first state that the flexible display unit 230 is folded.
- [221] The first transformation portion 235a may be formed at a position corresponding to the hinge unit 240, and can be bent for implementation of the first state that the flexible

display unit 230 is folded.

- [222] The second transformation portion 235b may be positioned in the first body 210, and can be bent for rolling of the flexible display unit 230 along the rotation body 251b of the first bearing 251.
- [223] As aforementioned, the first transformation portion 235a may be provided with a plurality of extension bars 235c. The first transformation portion 235a may be transformed into a shape corresponding to folding of the hinge unit 240, in order to implement the first state that the first and second bodies 210, 220 are overlapped with each other.
- [224] As shown in FIG. 9, if the hinge unit 240 is folded for implementation of the first state of the flexible display device 200, the first transformation portion 235a of the rear plate 231 may be transformed in correspondence to folding of the hinge unit 240.
- [225] More specifically, if the hinge unit 240 is folded, each extension bar 235c of the first transformation portion 235a, arranged to be overlapped with the hinge unit 240 up and down may have its position changed. That is, if the hinge unit 240 is folded, a distance between the neighboring extension bars 235c of the first transformation portion 235a is changed. Accordingly, as shown in FIG. 9, the first transformation portion 235a can be bent in correspondence to folding of the hinge unit 240.
- [226] As shown in FIGS. 8 and 9, when the hinge segments 241 of the hinge unit 240 are converted to a folding state from an unfolding state, a distance of the one end may become far from a rotation center of the hinge segments 241, and the flexible display unit 230 may be arranged to cover the one end.
- [227] That is, at the time of a folding operation, one upper end 232 of the flexible display unit becomes far from the rotation center of the hinge segments 241, whereas another lower end 233 of the flexible display unit becomes close to the rotation center. In this case, the first and second bodies 210, 220 may perform a relative sliding in order to compensate for the distance change.
- [228] That is, when the flexible display unit 230 is folded, it is required to compensate for a length change due to a transformation of the hinge unit 240. Accordingly, an elastic member 216 of the first body 210 may be extended or contracted to compensate for the length change due to a transformation of the hinge unit 240.
- [229] That is, if the flexible display unit 230 is folded together with the rear plate 231, the elastic member 216 installed at the first body 210 is extended or contracted to thus partially compensate for the length change due to a transformation of the hinge unit 240.
- [230] Here, a region of the rear plate 231 is fixed to the second body 220. Accordingly, as the elastic member 216 installed for sliding of the first body 210, and second links 214b installed at both sides of the elastic member 216 are extended and contracted, the

length change due to a transformation of the hinge unit 240 can be compensated.

[231] Further, since the elastic member 216 is installed at the third part 213, sliding of the first body 210 may be implemented.

[232] The third part 213 has a structure to be slidably inserted to the first and second parts 211, 212. One side of the third part 213 may be connected to one of the hinge segments 241.

[233] Here, one end of the elastic member 216 may be connected to the third part 213, and another end thereof may be connected to the first fixing housing 215a. The elastic member 216 may be configured to provide an elastic force to the third part 213, and to compensate for a distance due to bending of the hinge unit 240. Here, the elastic member 216 may provide an elastic force to the third part 213 in a direction which becomes far from the hinge unit 240.

[234] FIG. 10 is a sectional view showing a state that the flexible display unit 230 is rolled by the first bearing 251.

[235] Bearing portions for winding at least part of the rear plate 231 and the flexible display unit 230 thereon may be installed at one side of the first body 210.

[236] The bearing portions 251, 252 may include the first bearing 251 configured to wind the flexible display unit 230 thereon, and the second bearing 252 spaced from the first bearing 251 and configured to support the flexible display unit 230 in the first body 210.

[237] The first bearing 251 may be installed at a first bearing insertion groove 217 recessed at one side of the first part 211.

[238] The first bearing 251 may include a fixing shaft 251a coupled to the first body 210, and a rotation body 251b having a hollow part for inserting the fixing shaft 251a and configured to wind the flexible display unit 230 thereon.

[239] The rotation body 251b of the first bearing 251 may have a structure to be rotated with contacting a ball 251e.

[240] The first bearing 251 may form a movement of the flexible display unit 230 so that a part of the flexible display unit 230 is smoothly inserted into or withdrawn from the first body 210 together with the rear plate 231, when the flexible display device 200 is in the third state from the second state.

[241] The second transformation portion 235b may be formed at one end of the rear plate 231 in correspondence to the first bearing portion 251.

[242] The second transformation portion 235b may be positioned in the first body 210, and may be bent so that the flexible display unit 230 can be rolled along the rotation body 251b of the first bearing 251.

[243] As aforementioned, the second transformation portion 235b may be provided with the plurality of extension bars 235c. The second transformation portion 235b may be

transformed to correspond to the shape of an outer side surface of the first bearing 251, in order to implement the third state that the flexible display unit 230 exposed to the outside is extended, in the second state that the first and second bodies 210, 220 are unfolded in parallel.

[244] When the second transformation portion 235b is transformed to correspond to the shape of the outer side surface of the first bearing 251, a region of the flexible display unit 230 wound in the first body 210 is withdrawn, and the flexible display unit 230 exposed to the outside is extended.

[245] In this case, a user can utilize a large screen more conveniently by using the extended flexible display unit 230.

[246] That is, as shown in FIG. 10, for the third state of the flexible display device 200, the second transformation portion 235b of the rear plate 231 is transformed to correspond to the outer side surface of the first bearing 251. This can allow the flexible display unit 230 to be inserted into or withdrawn from the first body 210.

[247] If the second transformation portion 235b is transformed to correspond to the outer side surface of the first bearing 251, the position of the extension bars 235c of the second transformation portion 235b may be changed. As shown in FIG. 10, as a distance between the neighboring extension bars 235c of the second transformation portion 235b is changed, the second transformation portion 235b is transformed into a shape corresponding to the outer side surface of the first bearing 251.

[248] A second bearing insertion groove 218 recessed to insert the second bearing 252 may be formed at one side of the first part 211 of the first body 210. The second bearing insertion groove 218 may be formed at a position spaced from the first bearing insertion groove 217 by a predetermined distance.

[249] The second bearing insertion groove 218 may be formed to have a depth deeper than that of the second bearing 252. The second bearing 252 can perform a rotation and a linear movement in the second bearing insertion groove 218.

[250] Here, the second bearing 252 may serve to assist a movement of the flexible display unit 230, so that a region of the flexible display unit 230 of the flexible display device 200 is smoothly inserted into or withdrawn from the first body 210. For this, a member formed of a rubber material to increase a frictional force may be formed on the surface of the second bearing. Here, the member may be formed of a material which can absorb an impact due to a rotation of the flexible display unit 230.

[251] FIG. 11 is a perspective view showing a rear plate 331 according to another embodiment of the present disclosure. FIG. 12A is a partially enlarged view showing a molding member 336 coupled to the rear plate 331. And FIG. 12B is a sectional view showing a lamination structure of a flexible display unit 330 coupled to the rear plate 331.

- [252] The rear plate 331 is coupled to a rear surface of the flexible display unit 330, and may be transformed together with the flexible display unit 330.
- [253] The rear plate 331 may be formed to be folded or unfolded for implementation of first and second states of a flexible display device 300. Also, the rear plate 331 may be formed to be wound in the first body 210 at least partially. Here, the wound part of the rear plate 331 may be moved to the front surface of the first body 210 by interworking with a relative movement of a plurality of parts, so that an exposed region of the flexible display unit 330 is increased.
- [254] The rear plate 331 may be formed of stainless (STS) thin film. The rear plate 331 may be provided with mounting portions 333a, 333a' for coupling the rear surface of the flexible display unit 330, transformation portions 335a, 335b which are transformable in correspondence to a movement of the flexible display unit 330, and a bending supporting portion 334 extended towards the outside from both sides of the mounting portions.
- [255] The first and second transformation portions 335a, 335b of the rear plate 331 can be transformed through a position and a structure thereof, for implementation of folding, unfolding, rolling or unrolling of the flexible display unit 330. And a bonding member 337 is installed between the flexible display unit 330 and the mounting portions 333a, 333a' of the rear plate 331. These have been aforementioned, and thus detailed descriptions thereof will be omitted.
- [256] However, the flexible display device 300 according to this embodiment may be provided with the bending supporting portion 334 extended towards the outside from both sides of the mounting portions 333a, 333a' of the rear plate 331. Here, an outer side surface of the bending supporting portion 334 may have a flat shape.
- [257] A molding member 336 may be coupled to an upper surface of the bending supporting portion 334. A bottom surface of the molding member 336 may have a flat shape to correspond to the upper surface of the bending supporting portion 334, and an upper surface thereof may have a concavo-convex shape.
- [258] When folding or rolling of the rear plate 331 is performed in an opposite direction to folding or rolling of the flexible display unit 330, interference may occur at the concavo-convex structure formed on the upper surface of the molding member 336. As a result, folding or rolling of the rear plate 331 in the opposite direction to folding or rolling of the flexible display unit 330 may be restricted. That is, the molding member 336 may prevent counter-folding or counter-rolling of the rear plate 331.
- [259] The molding member 336 may maintain its parallel state when the flexible display unit 330 is unfolded, and may maintain its bent state when the flexible display unit 330 is folded or rolled. The molding member 336 may be formed of a material such as synthetic resin.

[260] The aforementioned flexible display device is not limited to the configurations and the methods of the embodiments described above, but all or some of the embodiments may be selectively combined so that various modifications can be made.

Industrial Applicability

[261] The embodiments of the present invention may be applied to a flexible display device having a flexible display unit.

Claims

- [Claim 1] A flexible display device, comprising:
a first body;
a second body;
a flexible display unit arranged on a front surface of the first and second bodies; and
a rear plate coupled to a rear surface of the flexible display unit, and configured to be transformed together with the flexible display unit, wherein in a folded state of the flexible display unit, the second body covers a rear surface of the first body, a first part of the rear plate is wound around a bearing portion in the first body together with a first part of the flexible display unit, and a second part of the rear plate is coupled to a second part of the flexible display unit exposed to the outside,
wherein in an unfolded state of the flexible display unit, the first body and the second body are arranged in parallel, and
wherein in an extending state of the flexible display unit from the unfolded state, the first body is extended and the first part of the rear plate is unwound from the bearing portion together with the flexible display unit to increase an exposed region of the flexible display unit.
- [Claim 2] The flexible display device of claim 1, wherein the rear plate includes: mounting portions extended in one direction, and recessed to couple the rear surface of the flexible display unit;
transformation portions having a plurality of extension bars arranged in parallel so as to cross the mounting portions, and configured to be transformed in correspondence to the flexible display unit; and
a bending supporting portion extended towards the outside from both sides of the mounting portions.
- [Claim 3] The flexible display device of claim 2, further comprising:
a bonding member between an upper surface of the rear plate and a bottom surface of the flexible display unit.
- [Claim 4] The flexible display device of claim 2, wherein the bending supporting portion is concaved downward, and
wherein a metallic supporting member is coupled to a bottom surface of the bending supporting portion, in correspondence to a shape of the bottom surface.
- [Claim 5] The flexible display device of claim 2, further comprising:

- a molding member having a concavo-convex shape coupled to an upper surface of the bending supporting portion.
- [Claim 6] The flexible display device of claim 2, wherein the transformation portions include:
a first transformation portion having a plurality of extension bars arranged in parallel and spaced from each other with predetermined intervals, so as to be transformed in correspondence to a folding and unfolding of the flexible display unit; and
a second transformation portion spaced from the first transformation portion, and having a plurality of extension bars arranged in parallel so as to be transformed in correspondence to the first part of the rear plate wound around the bearing portion.
- [Claim 7] The flexible display device of claim 1, wherein the first body includes a plurality of parts connected to each other so as to be relatively moveable, and
wherein the flexible display unit is changed into the extending state from the unfolded state, by being extended by a relative movement of the plurality of parts of the first body.
- [Claim 8] The flexible display device of claim 2, wherein the bearing portion is installed at a first side of the first body.
- [Claim 9] The flexible display device of claim 1, further comprising:
a hinge unit connecting the first body and the second body to each other such that the first body and the second body can be folded and unfolded with respect to each other, and
wherein the hinge unit is installed at another side of the first body.
- [Claim 10] The flexible display device of claim 9, wherein the hinge unit includes a plurality of hinge segments sequentially arranged in one direction, and enclosing a side surface of the first body in the folded state of the flexible display unit.
- [Claim 11] The flexible display device of claim 1, wherein the bearing portion includes:
a first bearing configured to wind the flexible display unit thereon; and
a second bearing spaced from the first bearing, and configured to support the flexible display unit in the first body, and
wherein the first body includes a groove for inserting the second bearing, and the second bearing performs a rotation and a linear movement in the groove.
- [Claim 12] The flexible display device of claim 7, wherein the plurality of parts of

the first body include:

a first part;

a second part coupled to the first part; and

a third part slidable between the first part and the second part.

[Claim 13]

The flexible display device of claim 12, further comprising:

a first extension unit arranged at the first body,

wherein the first extension unit includes a plurality of links rotatably connected to each other, and a first fixing housing and a second fixing housing arranged with the plurality of links are interposed therebetween, and

wherein the first fixing housing is coupled to the flexible display unit and is moveable in the first body, and the second fixing housing is fixed to the first body.

[Claim 14]

The flexible display device of claim 13, further comprising:

a second extension unit overlapping with the first extension unit,

having one side connected to the first part, and having another side connected to one end of the flexible display unit,

wherein the second extension unit includes a third fixing housing and a fourth fixing housing arranged with a plurality of links are interposed therebetween.

[Claim 15]

A flexible display device, comprising:

a first body having a plurality of parts connected to each other so as to be relatively moveable;

a second body connected to one side of the first body by a hinge unit, so as to be relatively rotatable with respect to the first body;

a flexible display unit configured to be folded and rolled, and arranged on a front surface of the first and second bodies;

a rear plate coupled to a rear surface of the flexible display unit, and configured to be transformed together with the flexible display unit; and

bearing portions installed at another side of the first body, and configured to wind at least part of rear plate together with the flexible display unit thereon,

wherein the flexible display unit is changed into an extending state from an unfolding state, by being unfolded together with the rear plate by a relative movement of the plurality of parts.

[Claim 16]

The flexible display device of claim 15, wherein the bearing portions include:

- a first bearing configured to wind the rear plate together with the flexible display unit thereon; and
- a second bearing spaced from the first bearing, and configured to support the rear plate with the flexible display unit in the first body.
- [Claim 17] The flexible display device of claim 15, wherein in a folded state of the flexible display unit, the second body covers a rear surface of the first body, a first part of the rear plate is wound around the bearing portion in the first body together with a first part of the flexible display unit and a second part of the rear plate is coupled to a second part of the flexible display unit exposed to the outside,
- wherein in an unfolded state of the flexible display unit, the first body and the second body are arranged in parallel, and
- wherein in an extending state of the flexible display unit from the unfolded state, the first body is extended and the first part of the rear plate is unwound from the bearing portion together with the flexible display unit to increase an exposed region of the flexible display unit.
- [Claim 18] The flexible display device of claim 17, wherein the rear plate includes: mounting portions extended in one direction, and recessed to couple the rear surface of the flexible display unit;
- transformation portions having a plurality of extension bars arranged in parallel so as to cross the mounting portions, and configured to be transformed in correspondence to the flexible display unit; and
- a bending supporting portion extended towards the outside from both sides of the mounting portions.
- [Claim 19] The flexible display device of claim 18, further comprising:
- a bonding member between an upper surface of the rear plate and a bottom surface of the flexible display unit.
- [Claim 20] The flexible display device of claim 18, wherein the bending supporting portion is concaved downward, and
- wherein a metallic supporting member is coupled to a bottom surface of the bending supporting portion, in correspondence to a shape of the bottom surface.

[Fig. 1]

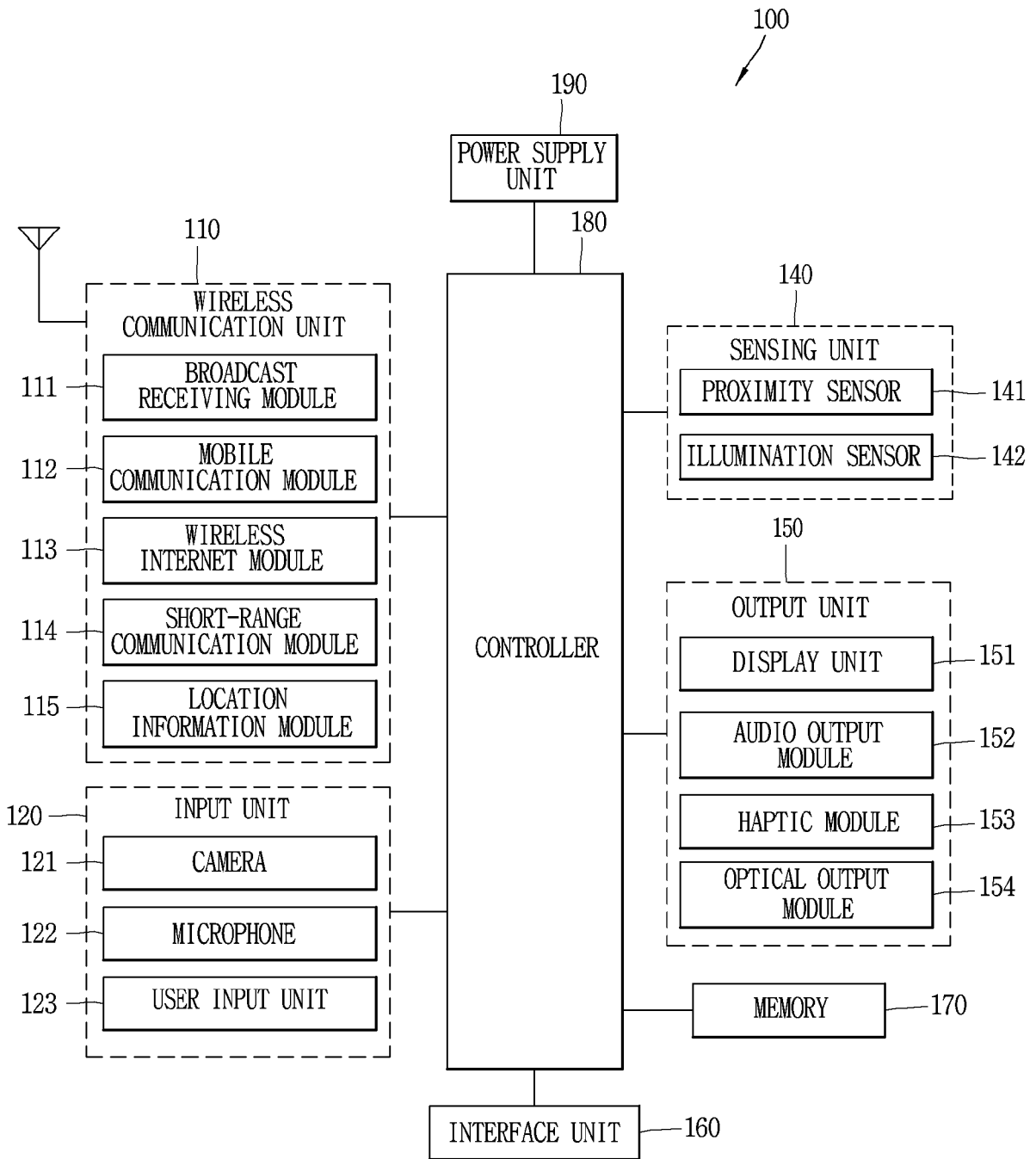

[Fig. 2a]

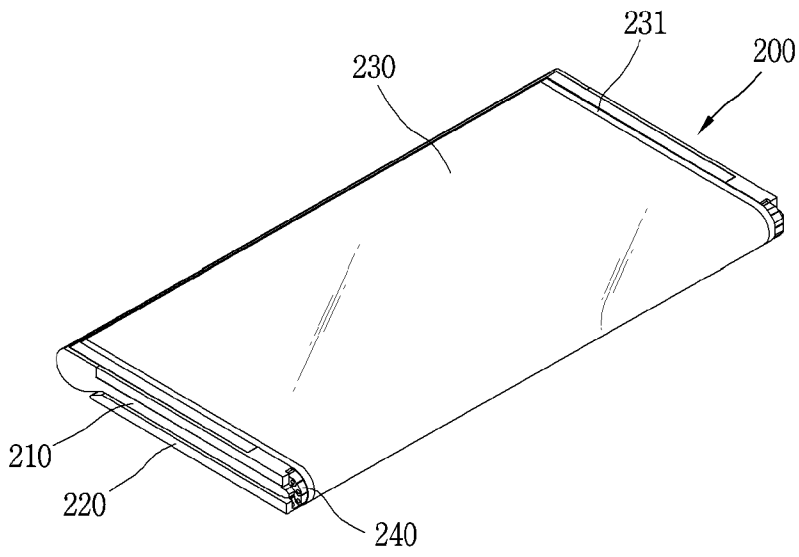

[Fig. 2b]

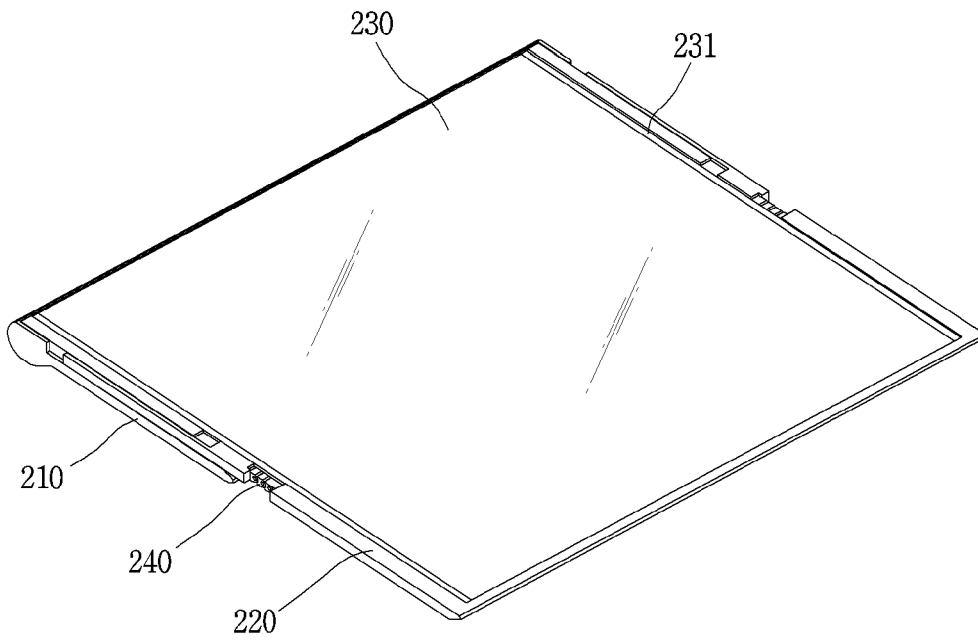

[Fig. 2c]

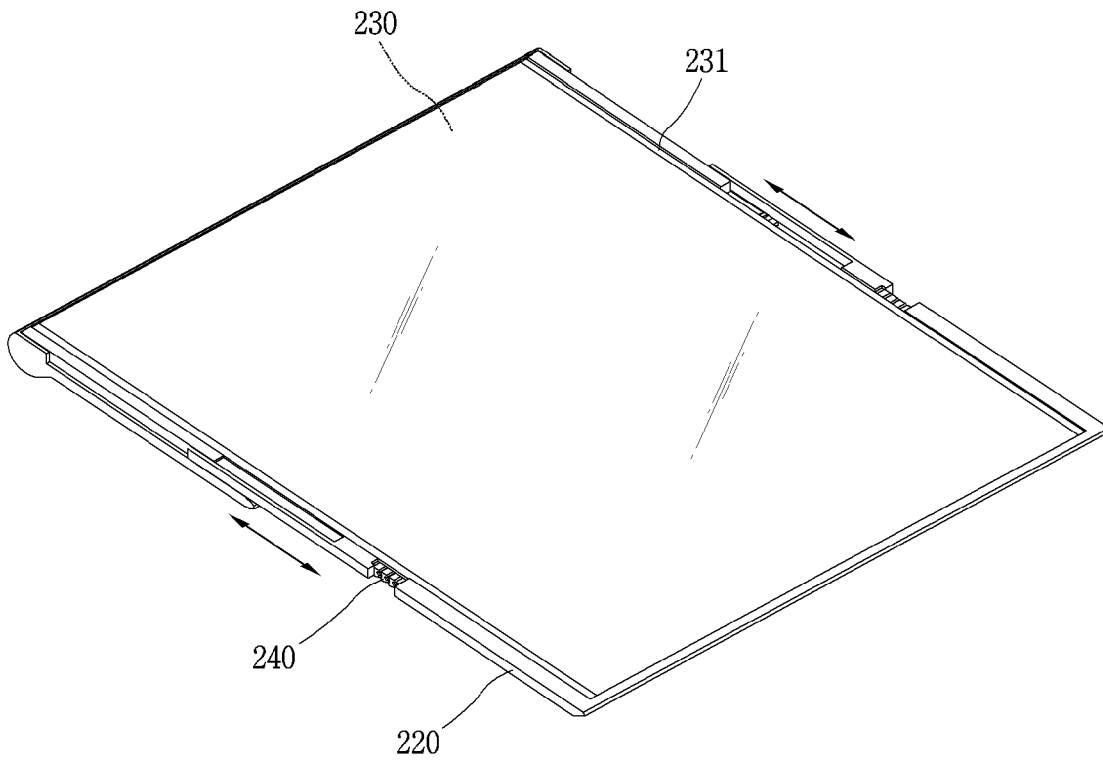

[Fig. 3a]

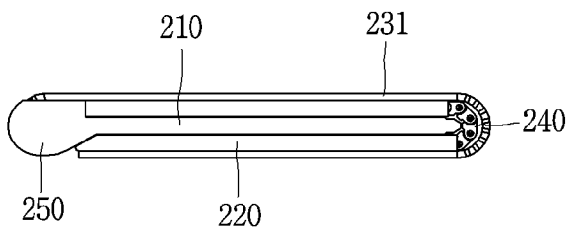

[Fig. 3b]

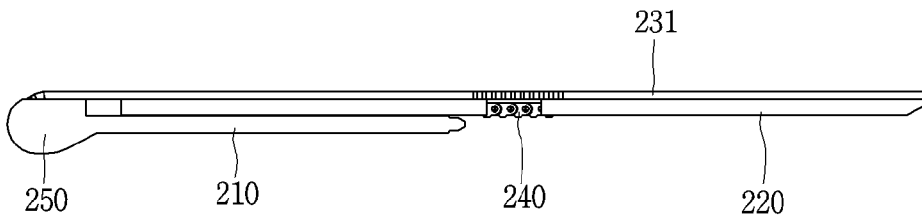

[Fig. 3c]

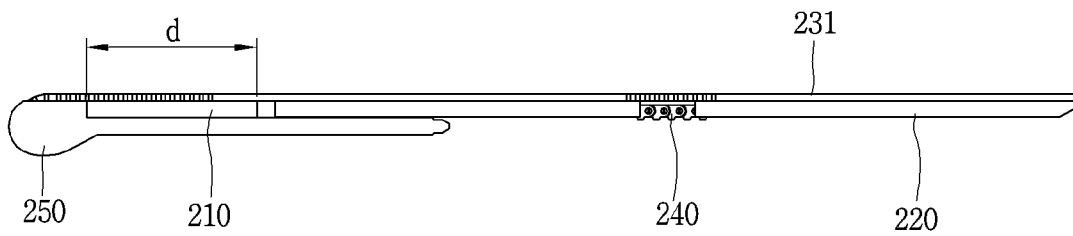

[Fig. 4]

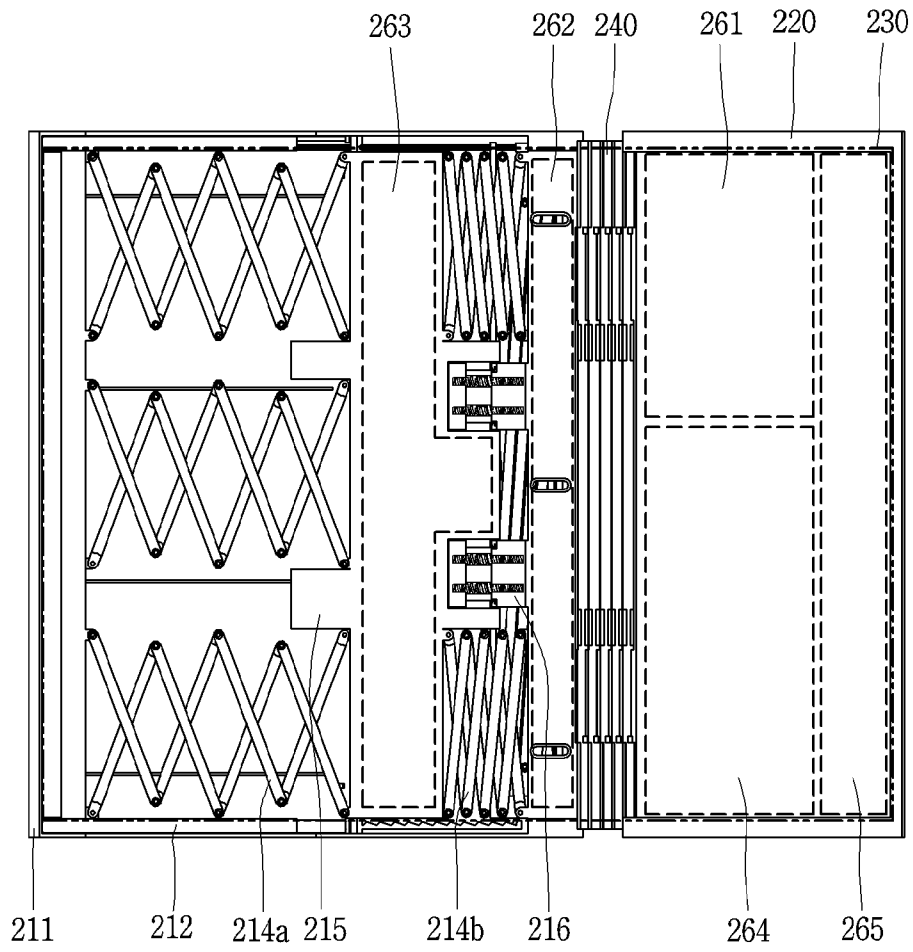

[Fig. 5]

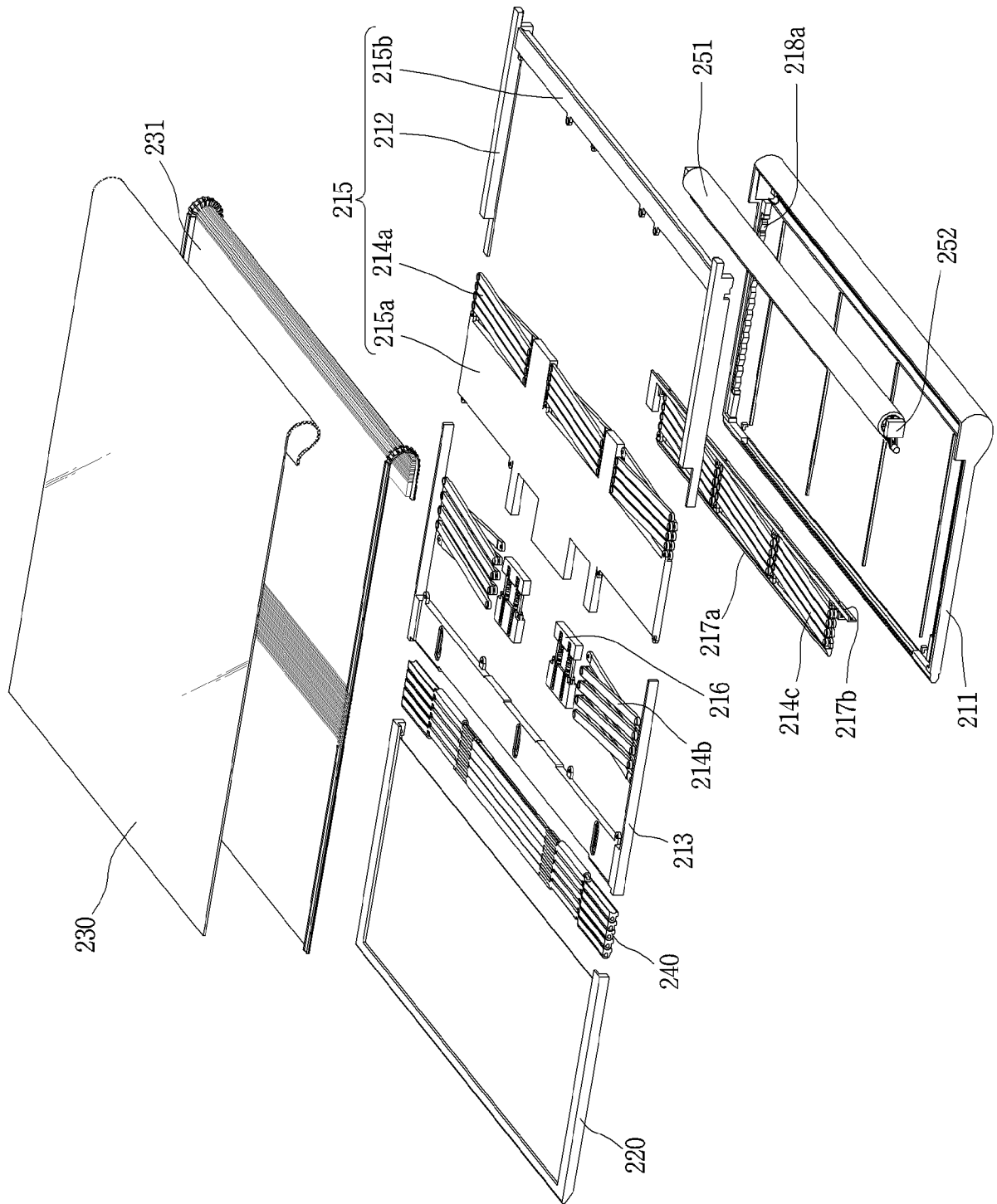

[Fig. 6]

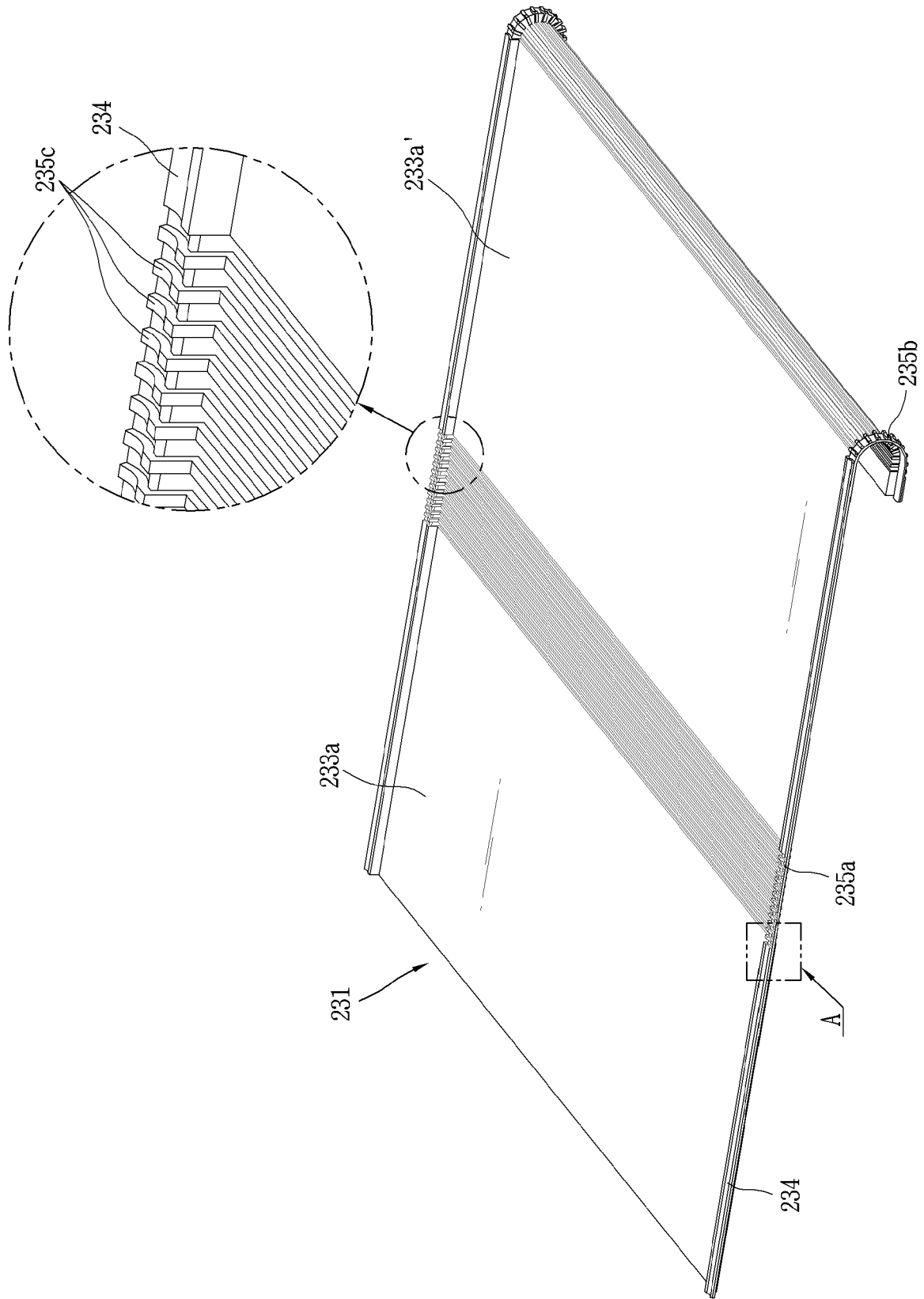

[Fig. 7a]

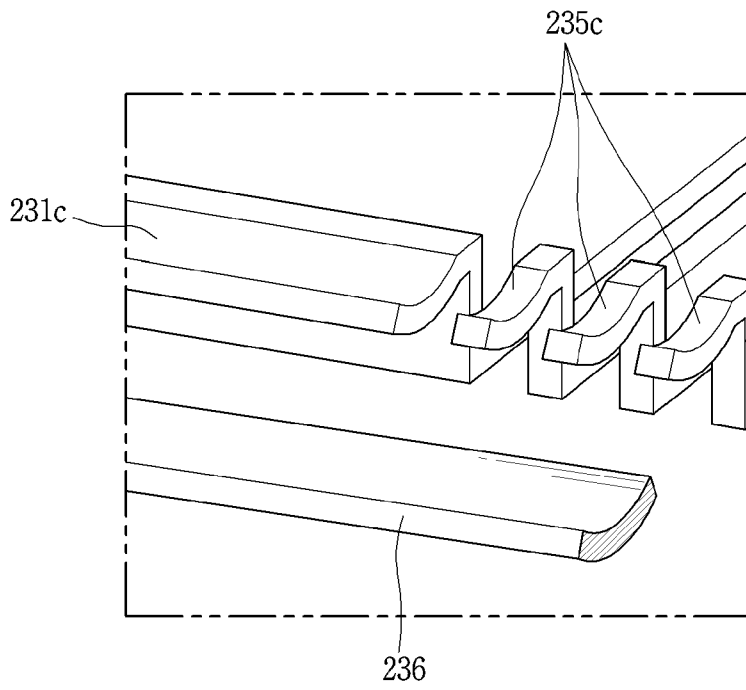

[Fig. 7b]

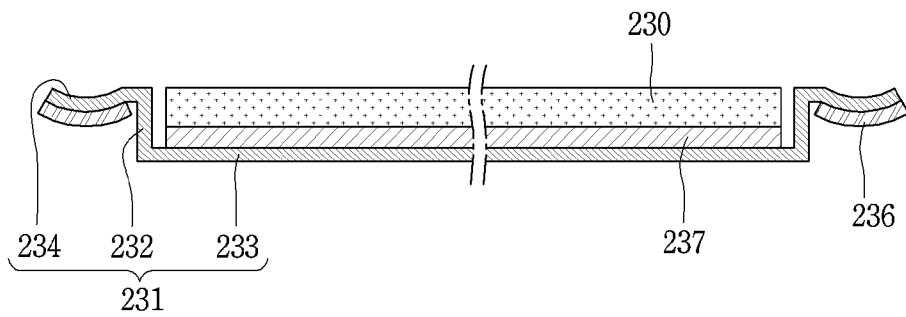

[Fig. 8]

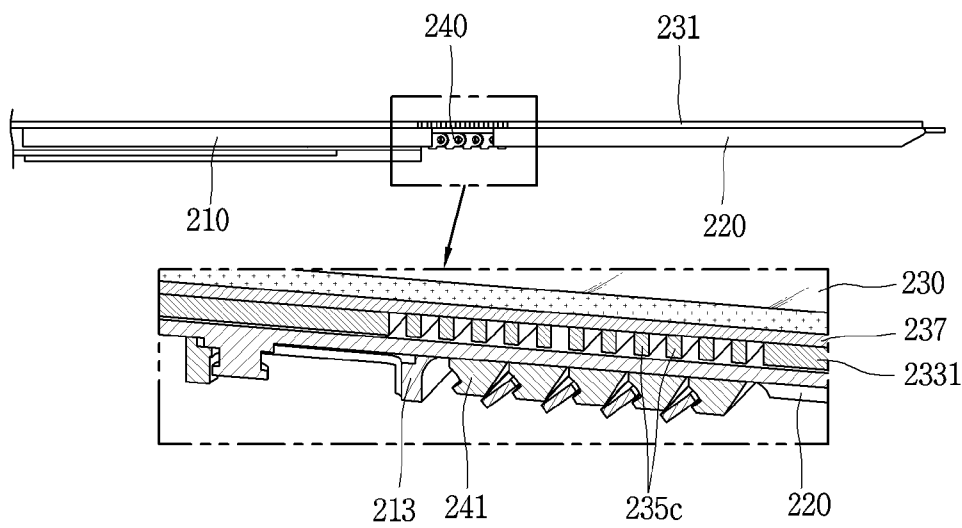

[Fig. 9]

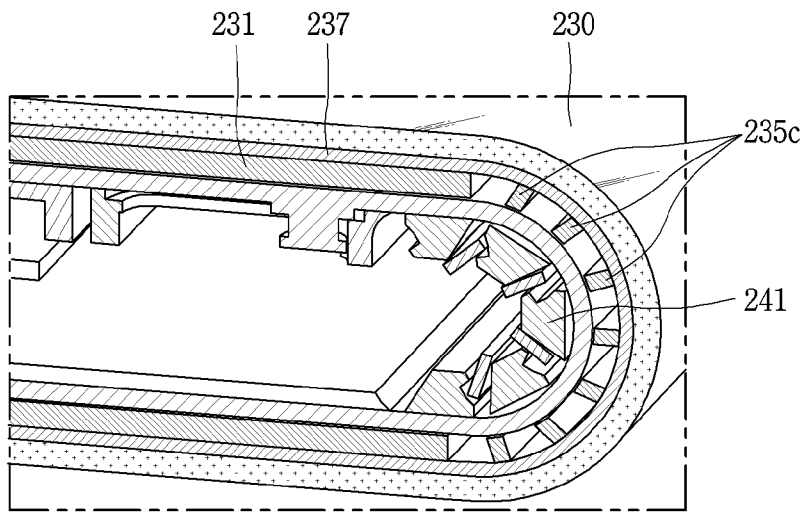

[Fig. 10]

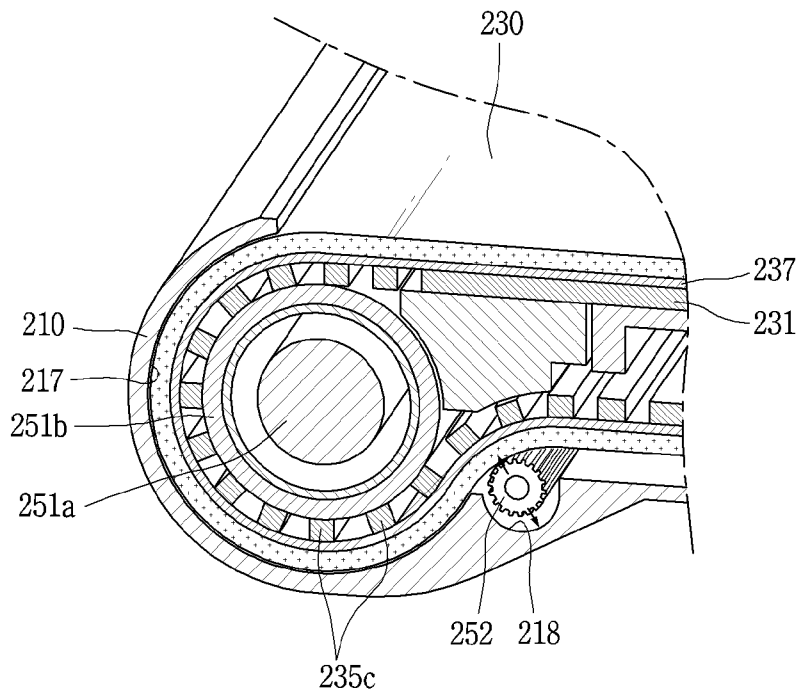

[Fig. 11]

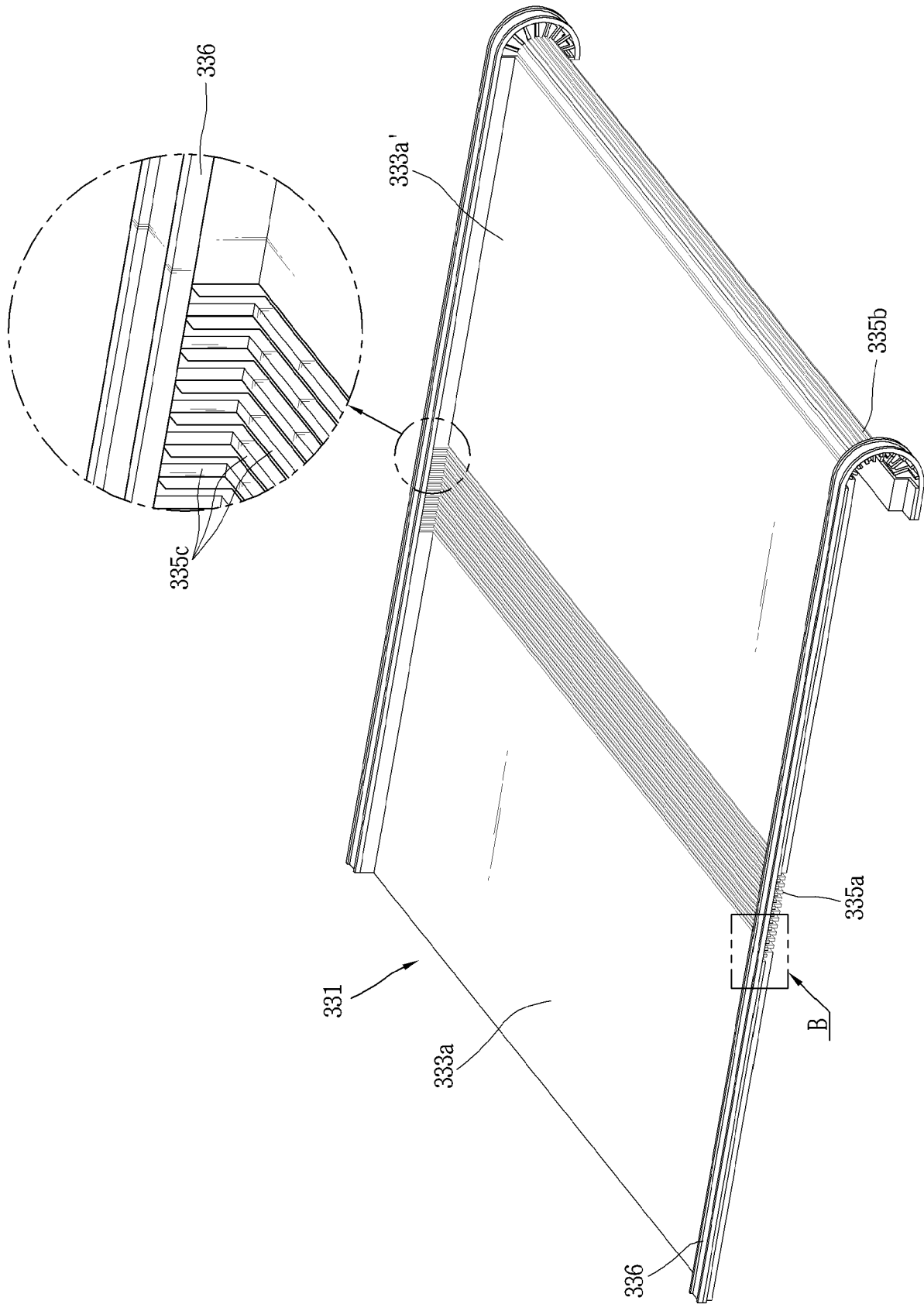

[Fig. 12a]

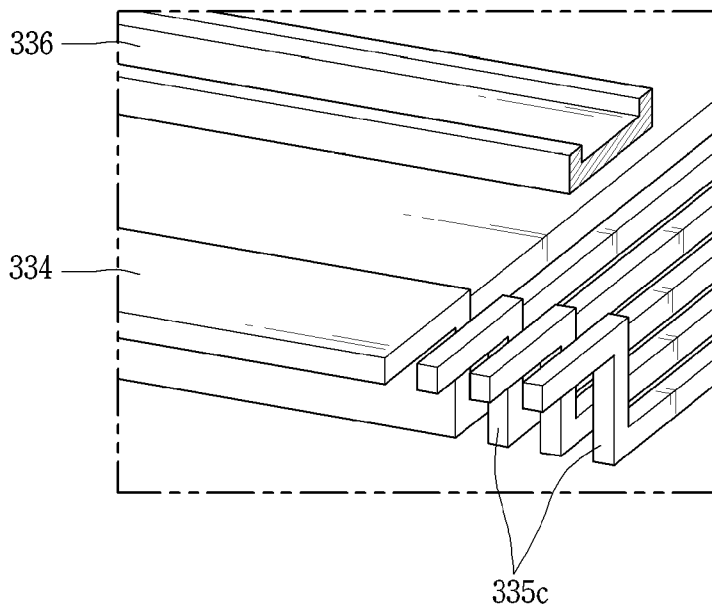

[Fig. 12b]

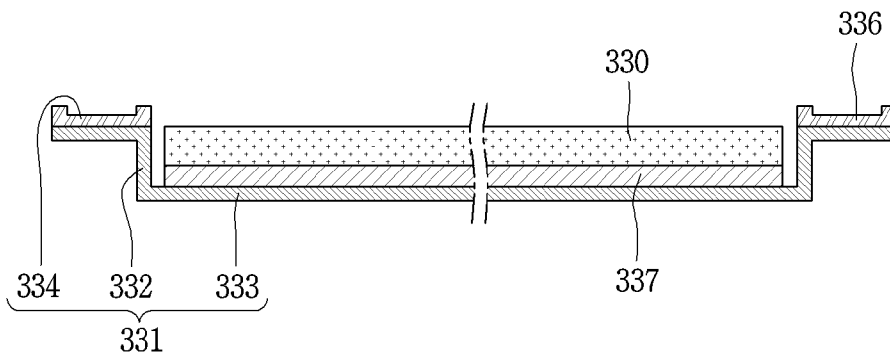

INTERNATIONAL SEARCH REPORT

International application No.
PCT/KR2020/000374**A. CLASSIFICATION OF SUBJECT MATTER****G09F 9/30(2006.01)i, G06F 1/16(2006.01)i, F16C 11/04(2006.01)i**

According to International Patent Classification (IPC) or to both national classification and IPC

B. FIELDS SEARCHEDMinimum documentation searched (classification system followed by classification symbols)
G09F 9/30; F16C 11/04; G06F 1/16; H04M 1/02Documentation searched other than minimum documentation to the extent that such documents are included in the fields searched
Korean utility models and applications for utility models
Japanese utility models and applications for utility modelsElectronic data base consulted during the international search (name of data base and, where practicable, search terms used)
eKOMPASS(KIPO internal) & keywords: flexible display, folding state, unfolding state, extending state, bearing, hinge, rear plate**C. DOCUMENTS CONSIDERED TO BE RELEVANT**

Category*	Citation of document, with indication, where appropriate, of the relevant passages	Relevant to claim No.
Y	KR 10-1784880 B1 (GANANHAN DONGJIDUL INC.) 16 October 2017 paragraphs [0065]-[0077]; and figures 19-26	1-20
Y	KR 10-2018-0107358 A (SENEKA CO., LTD.) 02 October 2018 paragraphs [0070], [0096]-[0101], [0106]; and figures 1, 6, 8-10	1-20
A	KR 10-2018-0064492 A (HUAWEI TECHNOLOGIES CO., LTD.) 14 June 2018 paragraphs [0042]-[0044]; and figures 3-5	1-20
A	US 2018-0174497 A1 (LIM, YOU SEOB) 21 June 2018 paragraphs [0079]-[0080]; and figure 6	1-20
A	US 2014-0211399 A1 (MICROSOFT CORPORATION) 31 July 2014 paragraphs [0017]-[0027]; and figures 1-2	1-20

 Further documents are listed in the continuation of Box C. See patent family annex.

* Special categories of cited documents:

"A" document defining the general state of the art which is not considered to be of particular relevance

"D" document cited by the applicant in the international application

"E" earlier application or patent but published on or after the international filing date

"L" document which may throw doubts on priority claim(s) or which is cited to establish the publication date of another citation or other special reason (as specified)

"O" document referring to an oral disclosure, use, exhibition or other means

"P" document published prior to the international filing date but later than the priority date claimed

"T" later document published after the international filing date or priority date and not in conflict with the application but cited to understand the principle or theory underlying the invention

"X" document of particular relevance; the claimed invention cannot be considered novel or cannot be considered to involve an inventive step when the document is taken alone

"Y" document of particular relevance; the claimed invention cannot be considered to involve an inventive step when the document is combined with one or more other such documents, such combination being obvious to a person skilled in the art

"&" document member of the same patent family

Date of the actual completion of the international search

16 April 2020 (16.04.2020)

Date of mailing of the international search report

16 April 2020 (16.04.2020)

Name and mailing address of the ISA/KR

International Application Division
Korean Intellectual Property Office
189 Cheongsa-ro, Seo-gu, Daejeon, 35208, Republic of Korea

Facsimile No. +82-42-481-8578

Authorized officer

KIM, Sung Hee

Telephone No. +82-42-481-3516



INTERNATIONAL SEARCH REPORT

Information on patent family members

International application No.

PCT/KR2020/000374

Patent document cited in search report	Publication date	Patent family member(s)	Publication date
KR 10-1784880 B1	16/10/2017	WO 2018-186631 A1	11/10/2018
KR 10-2018-0107358 A	02/10/2018	CN 207399686 U TW M554688 U	22/05/2018 21/01/2018
KR 10-2018-0064492 A	14/06/2018	CN 108076171 A EP 3349422 A1 EP 3349422 B1 JP 2019-506651 A US 2019-0032380 A1 WO 2018-090888 A1	25/05/2018 18/07/2018 16/10/2019 07/03/2019 31/01/2019 24/05/2018
US 2018-0174497 A1	21/06/2018	CN 207264687 U JP 3211702 U KR 10-1759612 B1 KR 10-1779012 B1 KR 10-2016-0020949 A US 10403177 B2 US 2017-0169741 A1 US 9934706 B2 WO 2016-024852 A2 WO 2016-024852 A3 WO 2016-024852 A9	20/04/2018 03/08/2017 20/07/2017 18/09/2017 24/02/2016 03/09/2019 15/06/2017 03/04/2018 18/02/2016 28/04/2016 18/02/2016
US 2014-0211399 A1	31/07/2014	CN 102902308 A CN 102902308 B EP 2751639 A2 EP 2751639 B1 ES 2616031 T3 HK 1178634 A1 JP 2014-531796 A JP 6151253 B2 KR 10-1993390 B1 KR 10-2014-0059274 A KR 10-2019-0077107 A TW 201315196 A TW I584626 B US 2013-0058063 A1 US 8711566 B2 US 9195272 B2 WO 2013-033479 A2 WO 2013-033479 A3	30/01/2013 17/08/2016 09/07/2014 16/11/2016 09/06/2017 14/07/2017 27/11/2014 21/06/2017 26/06/2019 15/05/2014 02/07/2019 01/04/2013 21/05/2017 07/03/2013 29/04/2014 24/11/2015 07/03/2013 25/04/2013