



US006970096B2

(12) **United States Patent**
Nagata et al.

(10) **Patent No.:** **US 6,970,096 B2**
(45) **Date of Patent:** **Nov. 29, 2005**

(54) **TRANSMITTER USED FOR
REMOTE-CONTROL SYSTEM**

5,885,159 A * 3/1999 DeAngelis 463/39
6,037,858 A 3/2000 Seki
6,175,784 B1 1/2001 Jicha et al.
2004/0039495 A1 2/2004 Yamaguchi et al.

(75) Inventors: **Akihiko Nagata**, Tokyo (JP); **Takashi Yamaguchi**, Tokyo (JP); **Jingo Wada**, Tokyo (JP)

FOREIGN PATENT DOCUMENTS

(73) Assignee: **Konami Corporation**, Tokyo (JP)

DE 36 18 464 12/1987
FR 2 757 553 5/1996
GB 2 350 919 12/2000

(*) Notice: Subject to any disclaimer, the term of this patent is extended or adjusted under 35 U.S.C. 154(b) by 599 days.

(Continued)

OTHER PUBLICATIONS

(21) Appl. No.: **09/989,274**

Derwent abstract of DE 3618464, Dec. 3, 1987, Derwent Acc No. 1987-342928.*

(22) Filed: **Nov. 20, 2001**

Primary Examiner—Edwin C. Holloway, III

(65) **Prior Publication Data**

US 2003/0016138 A1 Jan. 23, 2003

(74) *Attorney, Agent, or Firm*—Jordan and Hamburg LLP

(30) **Foreign Application Priority Data**

Jul. 17, 2001 (JP) 2001-217301

(57) **ABSTRACT**

(51) **Int. Cl.⁷** **G08C 19/00**

To provide a transmitter suitable for making it possible to change the identification information for a drive by using the data transmitted from a transmitter. The transmitter comprises a data generation device for alternately generating the data for controlling operations of a drive or the data for changing the identification information for the drive in accordance with an operation of a predetermined input unit performed by a user, a transmission device including a first transmission section and a second transmission section provided on positions different from each other on a casing for covering a transmitter and capable of transmitting the generated data from the transmission sections, and a transmission-section change device for changing transmission sections used for data transmission in accordance with the type of data so that the data for controlling operations of the drive is transmitted from the first transmission section and the data for changing the identification information for the drive is transmitted from the second transmission section.

(52) **U.S. Cl.** **340/825.22; 340/825.69**

(58) **Field of Search** 340/825.22, 825.69, 340/825.72, 5.61–5.64, 5.23, 426.13, 501; 318/16, 581; 701/2; 307/10.5; 446/454–467; 180/187; 398/106, 111, 112; 246/187 B; 455/99; 463/6, 39; 341/176

(56) **References Cited**

U.S. PATENT DOCUMENTS

3,639,755 A * 2/1972 Wrege 246/187 B
4,334,221 A * 6/1982 Rosenhagen et al. 463/6
5,077,547 A * 12/1991 Burgmann 340/501
5,334,076 A 8/1994 Shinozuka
5,355,525 A * 10/1994 Lindmayer et al. 455/99
5,781,143 A 7/1998 Rossin

10 Claims, 13 Drawing Sheets

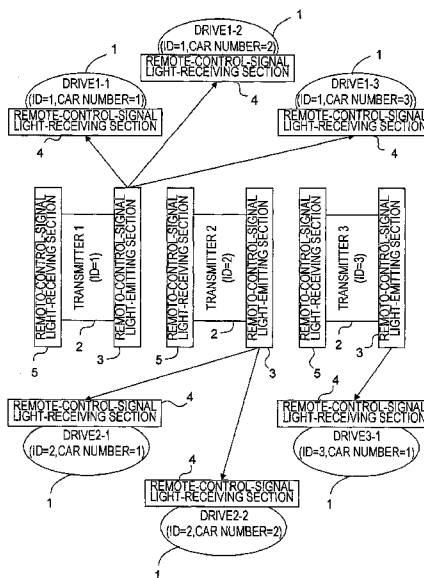

FOREIGN PATENT DOCUMENTS					
JP	02-252395	10/1990	JP	10-66165	3/1998
JP	05-308678	11/1993	JP	11-069465	3/1999
JP	6-12846	1/1994	JP	2000-051541	2/2000
			* cited by examiner		

FIG. 1

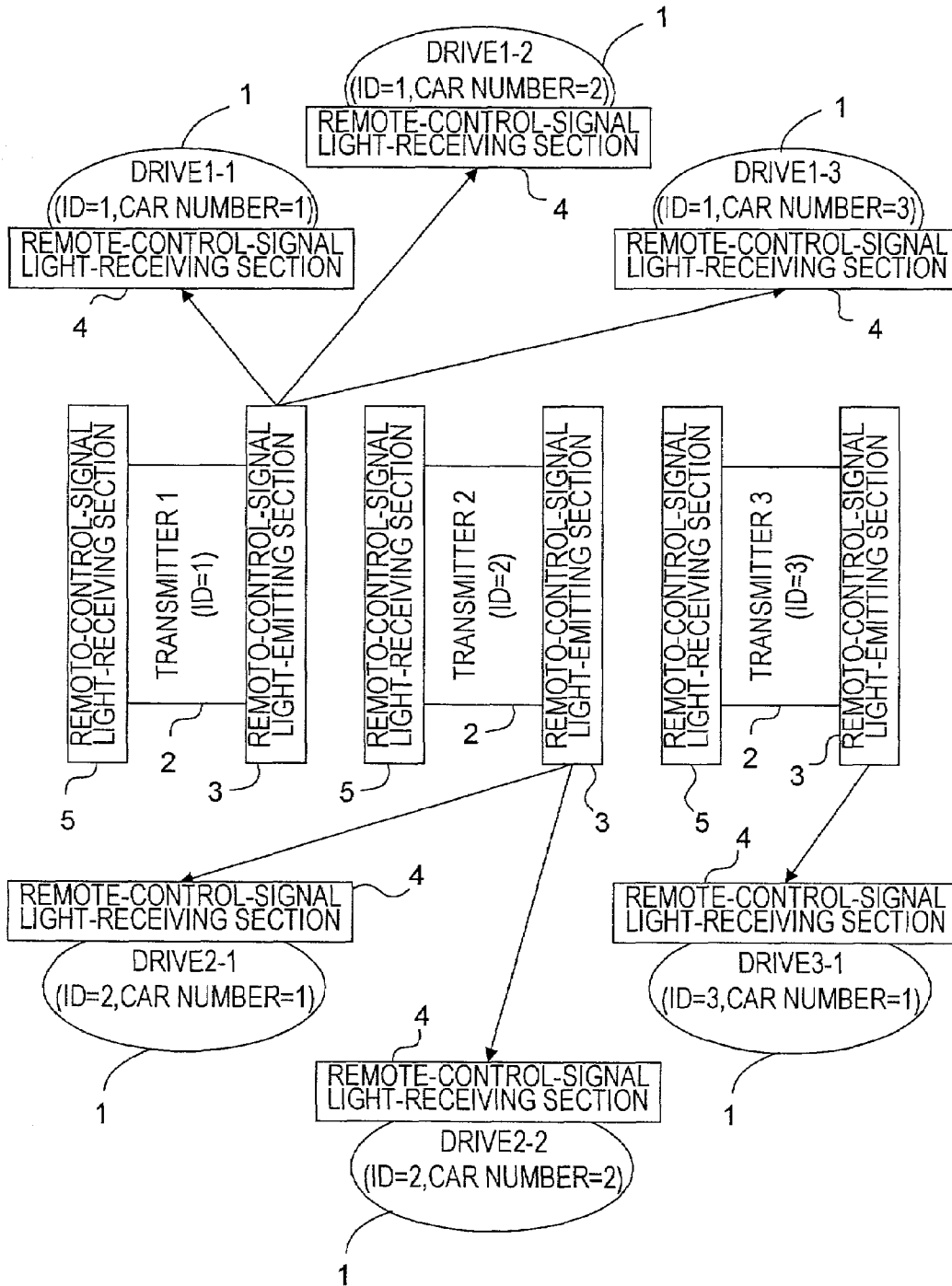

FIG.2

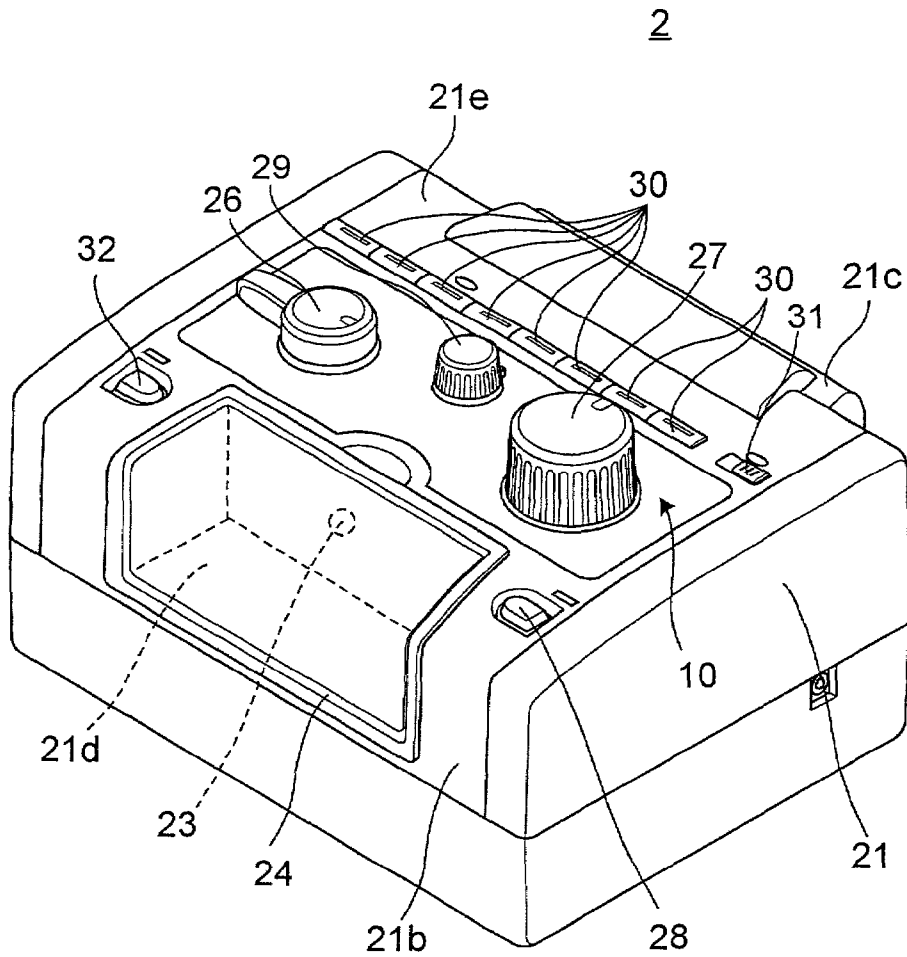

FIG. 3

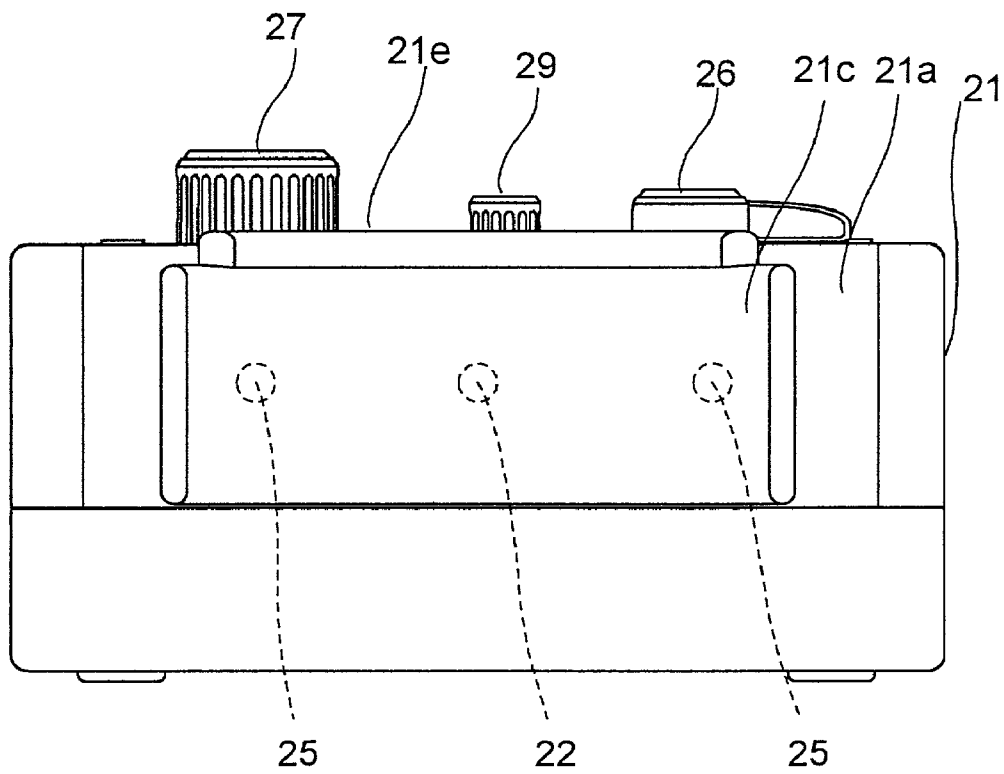

FIG. 4

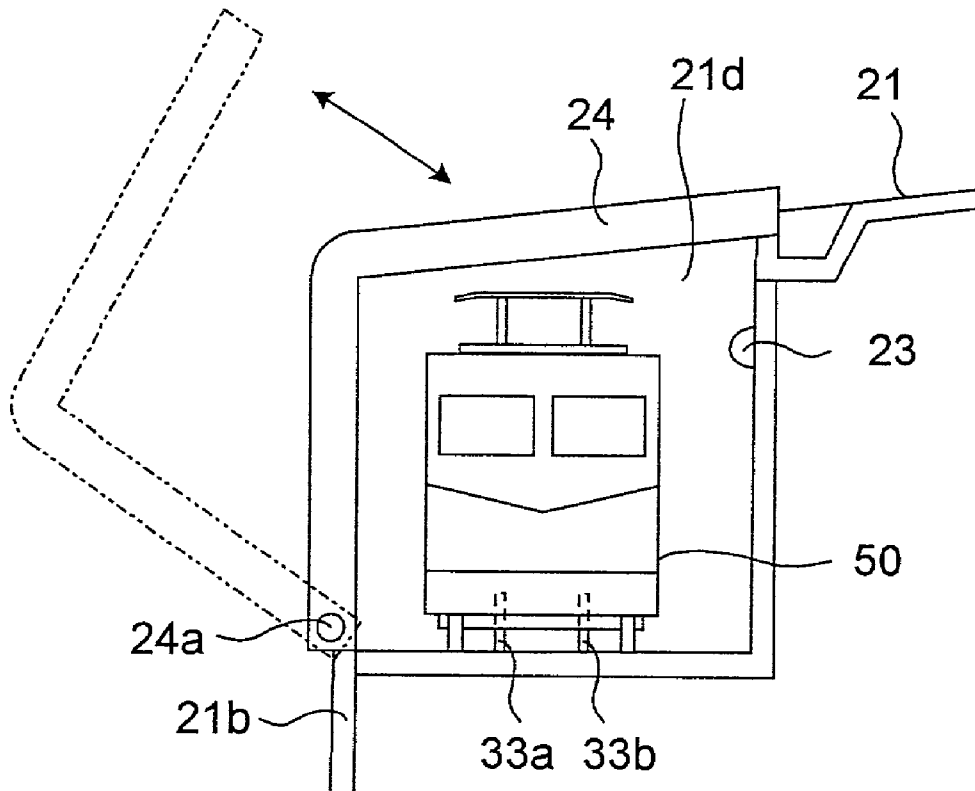

FIG. 5

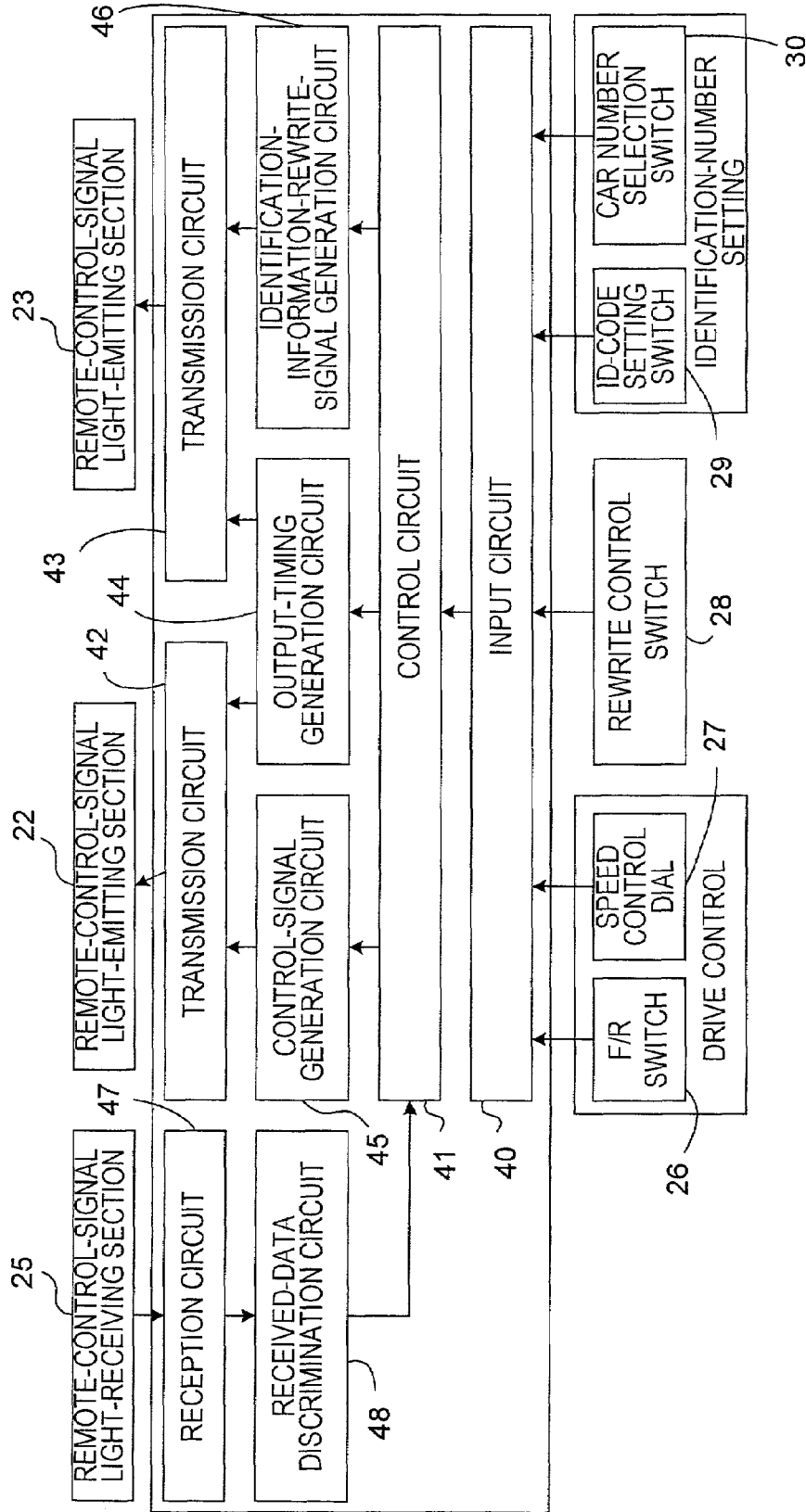

FIG. 6A

CASE OF TRANSMISSION OF CONTROL DESIGNATION SIGNAL

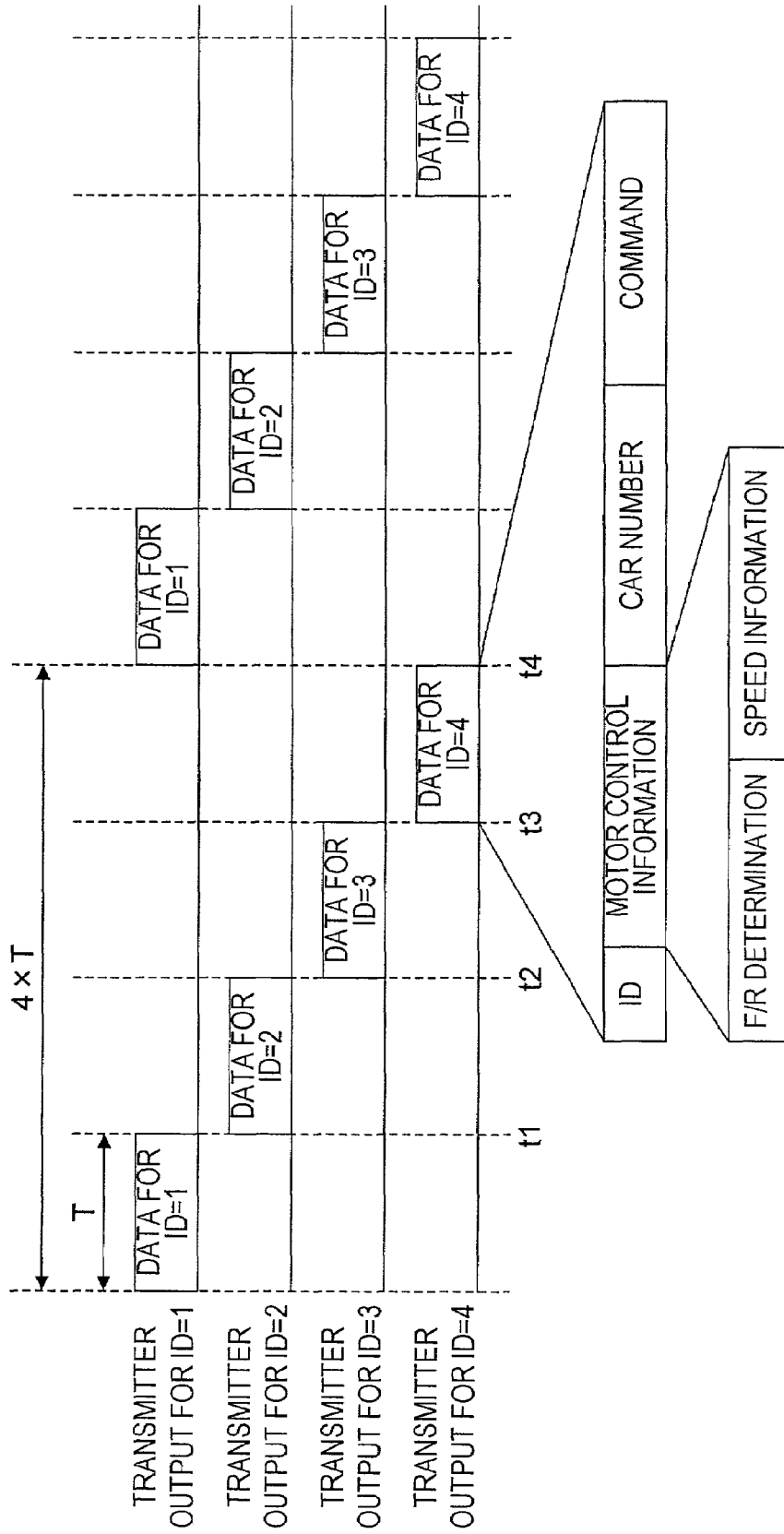

FIG.6B

CASE OF TRANSMISSION OF IDENTIFICATION-INFORMATION-REWRITE- DESIGNATION SIGNAL

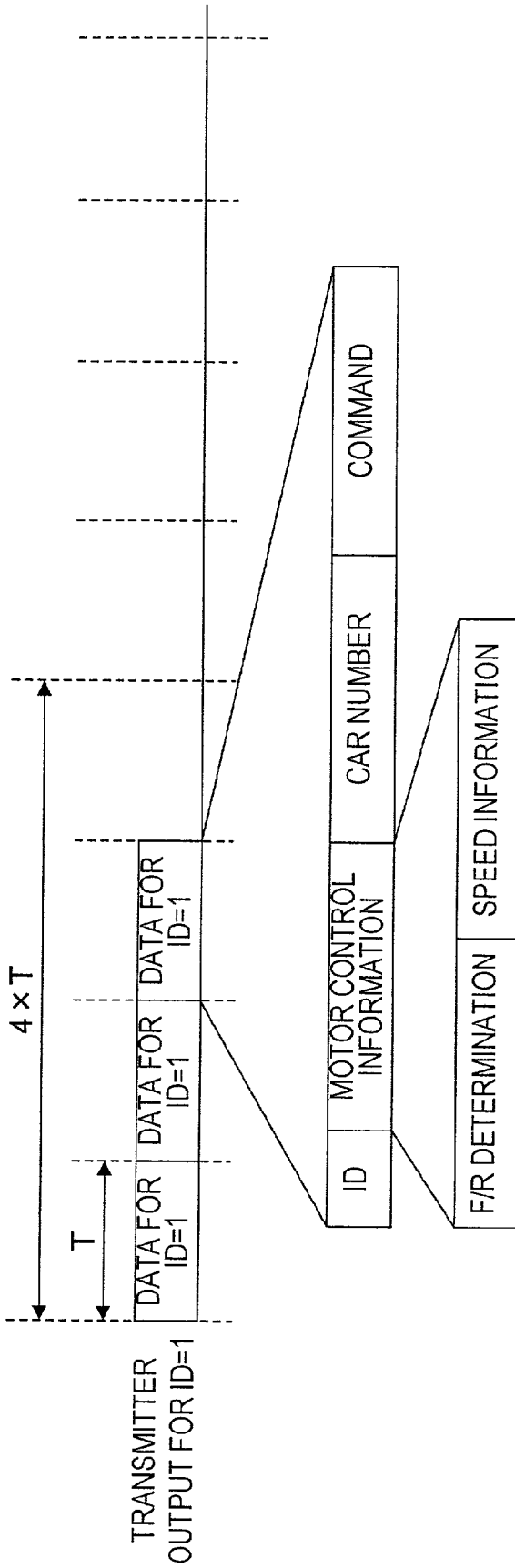

FIG. 7

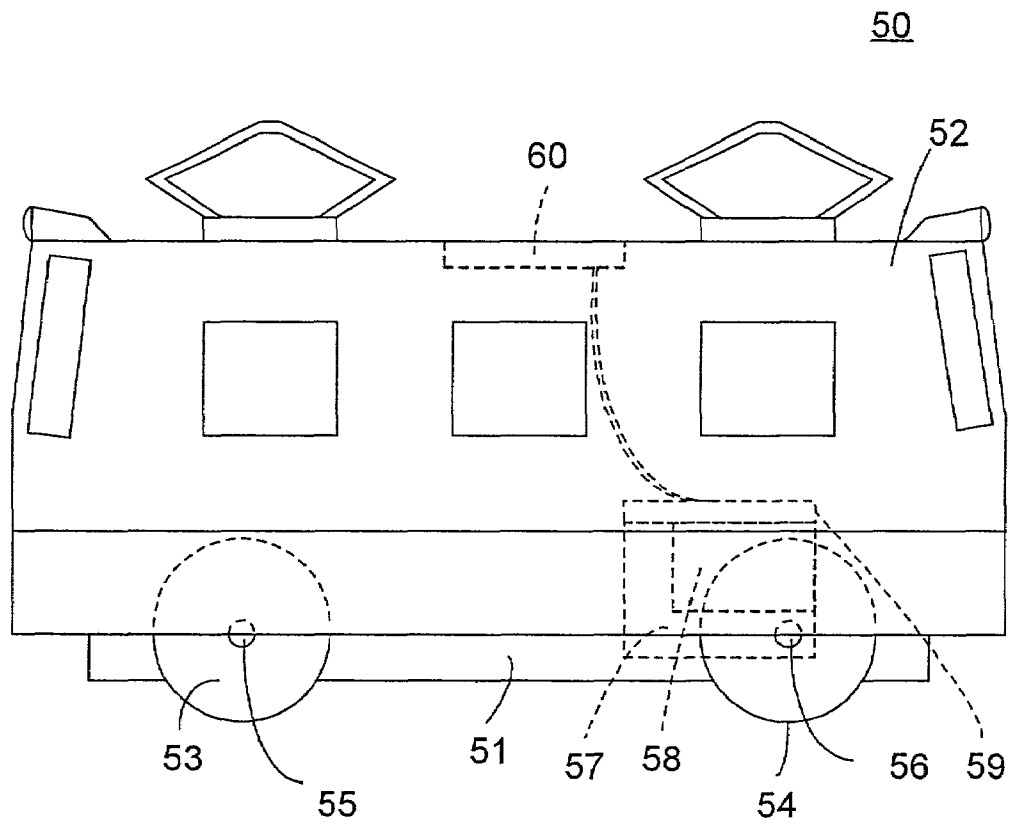

FIG. 8

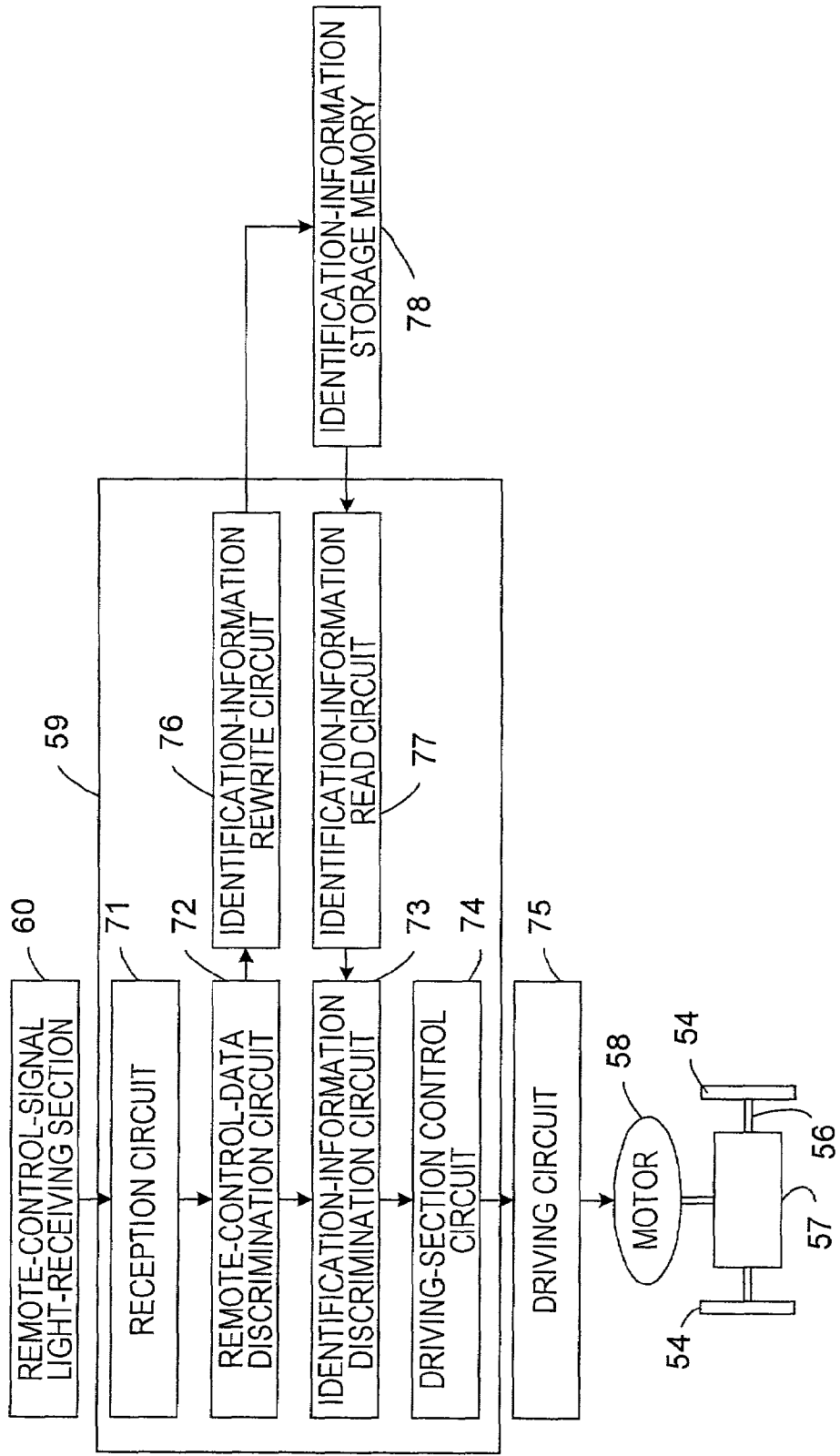

FIG.9

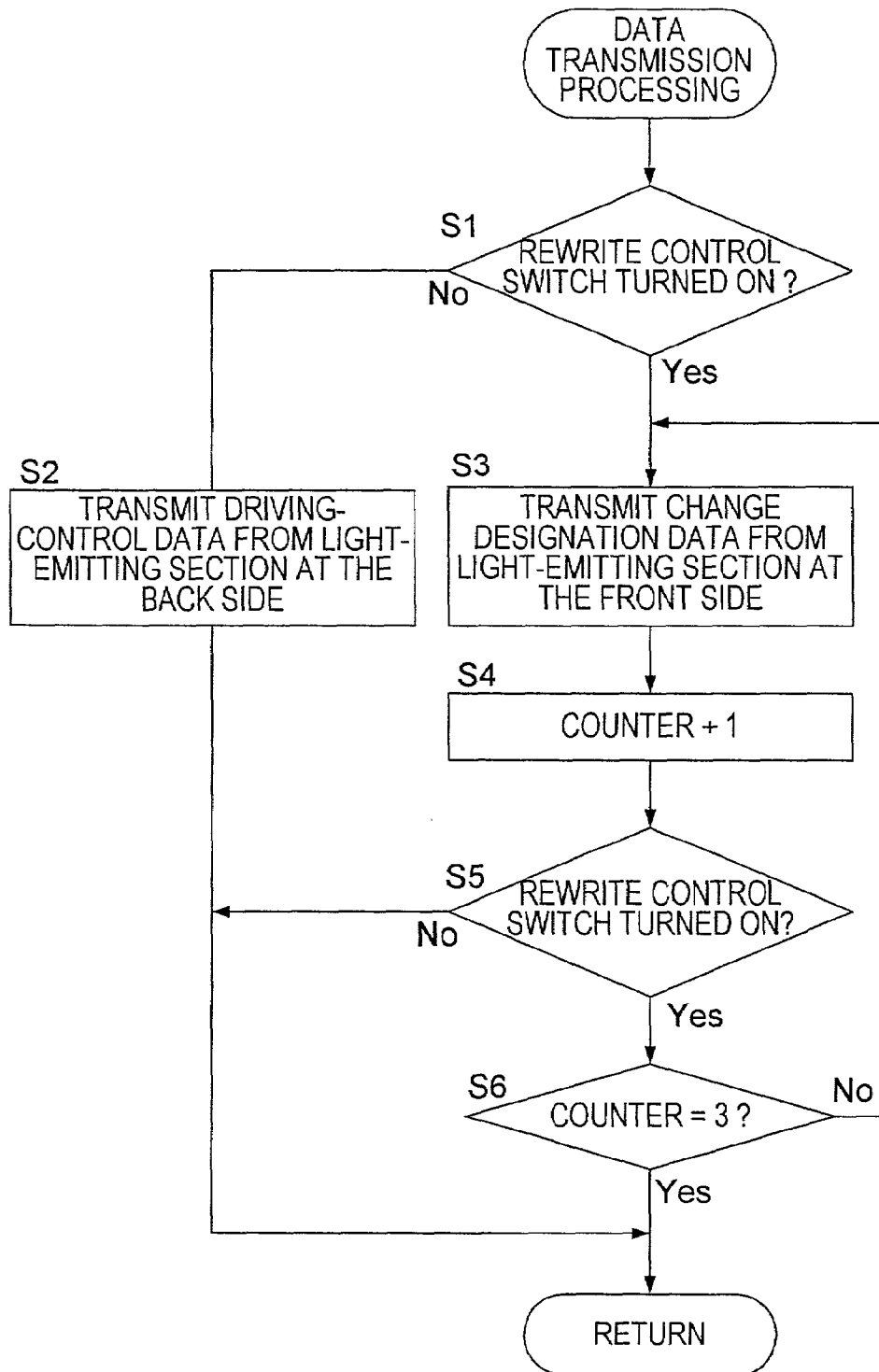

FIG. 10

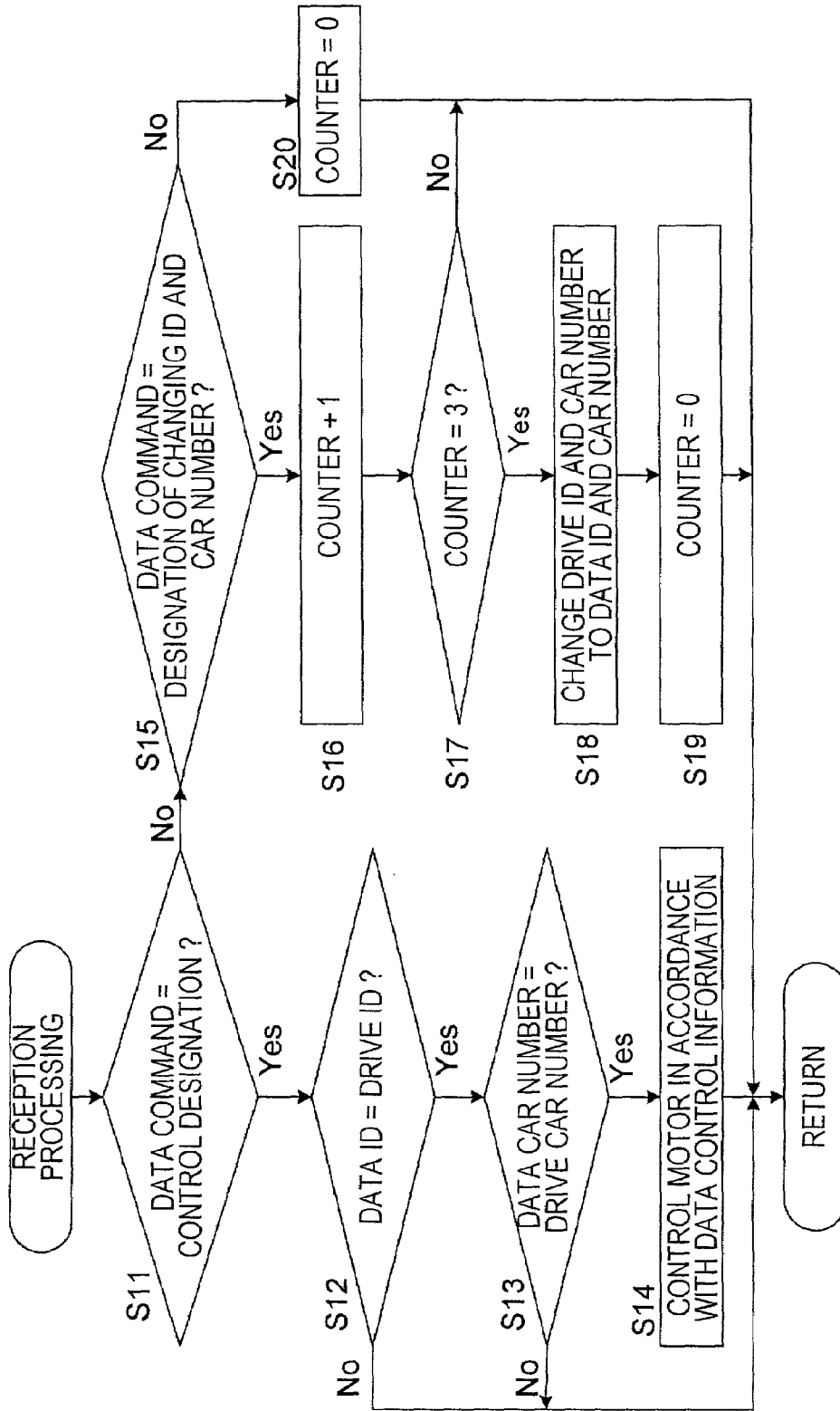

FIG. 11A

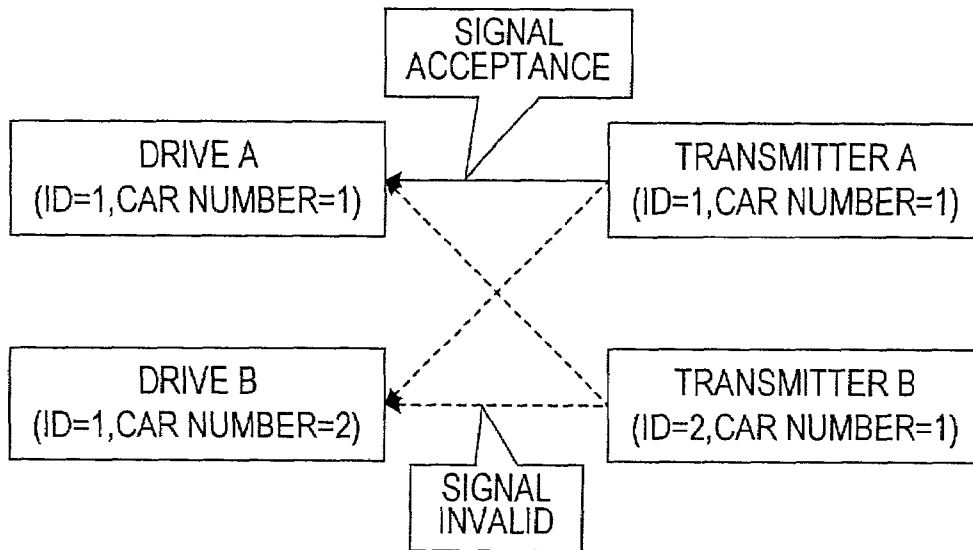

FIG. 11B

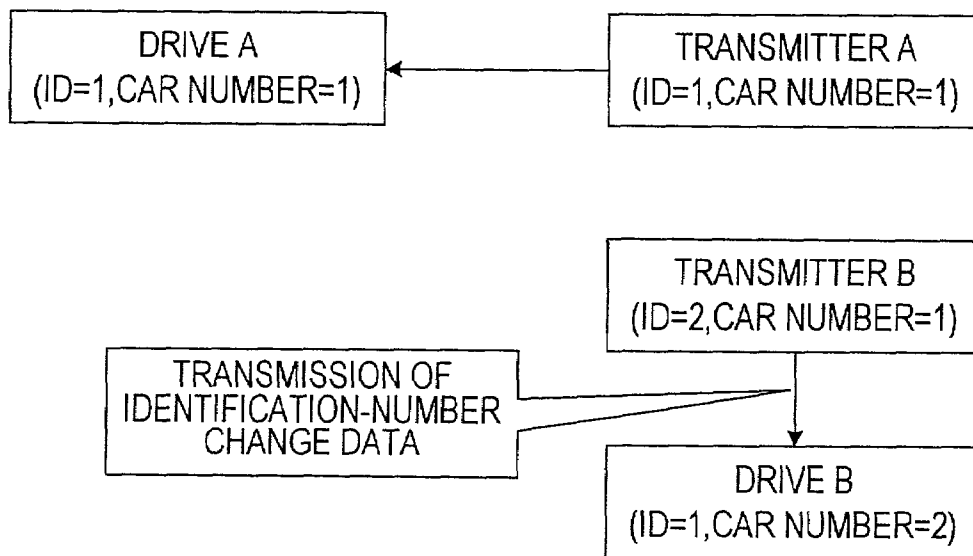

FIG.12A

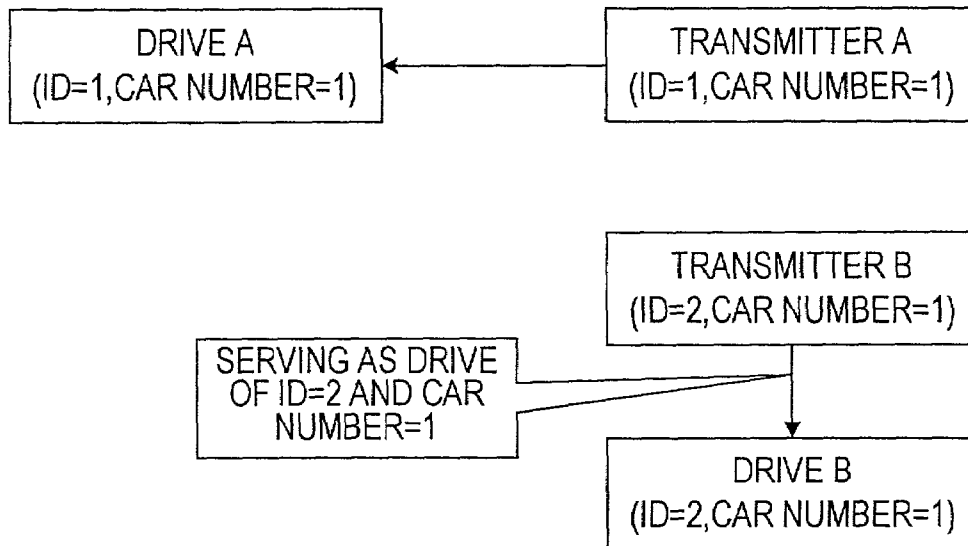
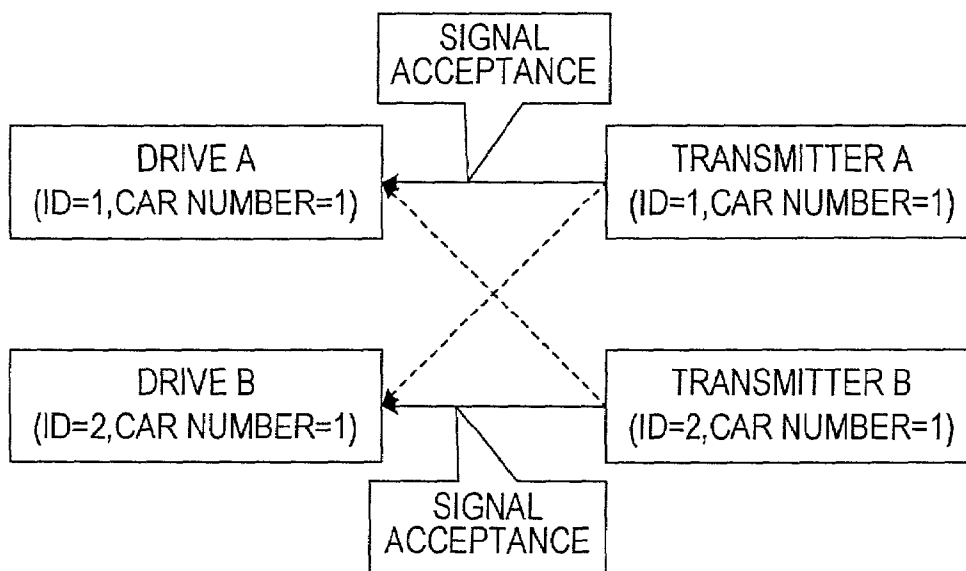

FIG.12B



TRANSMITTER USED FOR REMOTE-CONTROL SYSTEM

BACKGROUND OF THE INVENTION

1. Field of the Invention

The present invention relates to a transmitter used for a system for remote-controlling a drive, such as an automobile or robot.

2. Description of the Prior Art

When remote-controlling a plurality of drives at the same place by using infrared radiation or radio waves, it may be difficult to accurately control the drives because signals output from a transmitter to the drives interfere with each other. As a remote-control system for solving the problem, a system is studied which sets identification information to a transmitter and drives respectively and separates relations between the transmitter and the drives from each other in accordance with match or mismatch of these pieces of identification information. In the case of the system, the transmitter is provided with means for transmitting the data including identification information for specifying a drive to be controlled and control information for controlling the drives and each of the drives is provided with means for comparing the identification information included in received data with identification information set to the drive to decide whether control information included in the received data is information for the drive or not. Moreover, when the pieces of identification information are matched with each other, the controller of the drive decides the control information for the drive and controls operations in accordance with the control information.

In the case of the above remote control system, even if a plurality of transmitters are used, it is possible to accurately control a purposed drive for every transmitter by changing identification information for each transmitter. Moreover, by making it possible for one transmitter to alternately use a plurality of types of identification information, it is possible to selectively control a plurality of drives by the transmitter.

SUMMARY OF THE INVENTION

It is an object of the present invention to provide a transmitter preferred to make it possible to change the identification information for a drive by using the data transmitted from the transmitter in the case of a remote-control system for separating relations between the transmitter and the drive in accordance with the identification information included in the data sent from the transmitter.

In order to achieve the above object, according to the present invention, there is provided a transmitter used for a remote-control system, the system making it possible to separately control a plurality of drives by relating a transmitter with a drive to be remote-controlled by the data sent from the transmitter in accordance with identification information included in the data, wherein the transmitter comprises a data generation device for alternately generating the data for controlling operations of the drive or the data for changing the identification information for the drive in accordance with an operation of a predetermined input unit performed by a user, a transmission device including a first transmission section and a second transmission section whose transmission-destination areas are different from each other and capable of transmitting the data generated through the data generation device from these transmission sections, and a transmission-section change device for changing transmission sections to be used for data transmission in

accordance with the type of data so that the data for controlling operations of the drive is transmitted from the first transmission section and the data for changing the identification information for the drive is transmitted from the second transmission section.

According to the transmitter of the present invention, the data for controlling operations of the drive and the data for changing the identification information for the drive are output from the first and second transmission sections of which transmission-destination areas are different from each other. Therefore, when a plurality of drives are used, it is possible to arrange at least one of the drives in the transmission-destination area of the first transmission section to control operations thereof, while arranging another one of the drives in the transmission-destination area of the second transmission section to change the identification information thereof. There is no fear that the identification-information-change data reaches a drive whose operations are controlled in accordance with the data sent from the first transmission section and the identification information for the drive is changed on the contrary to the intention of a user, while the identification information of another drive is changed.

In the case of a transmitter according to the present invention, it may be allowed that the second transmission section is provided on a front side of a casing of the transmitter when it is viewed from a user, while the first transmission section is provided on a back side of the casing thereof. In this case, because the operation control data and the identification-information change data are transmitted in directions opposite to each other, the transmission areas of these data are separated and thereby, this is preferable in preventing the data from interfering with each other. Moreover, this is convenient for a user because it is possible to change the identification information for a drive without changing positions or directions of a transmitter while controlling operations of the drive by directing the first transmission section toward the drive.

It may also be allowed to provide the concave portion capable of housing the drive in the casing and provide the second transmission section in the concave portion. In this case, because the identification-information-change data is sent to the drive housed in the concave portion, it is possible to prevent the data from diffusing to the outside. When the concave portion can be closed by a predetermined lid while housing the drive, it is possible to suppress the identification-information-change data from leaking to the outside of the concave portion and more securely prevent the identification information from being unintentionally changed.

It may be allowed to provide charge terminals for charging a power-source battery of the drive in the concave portion. Thus, by housing the drive in the concave portion, it is possible to charge the power-source battery and change the identification information at the same time.

It may be allowed that the first and second transmission sections serve as infrared-radiation emitting sections. To transmit data with using infrared radiation, it is preferable to constitute the lid by a material for suppressing or preventing infrared radiation from passing. However, even when transmitting data through radio waves, it is possible to realize a transmitter according to the present invention by setting a structure for providing directivity for the radio waves to each transmission section.

It is possible to use one or more first transmission sections and one or more second transmission sections for the present invention.

BRIEF DESCRIPTION OF THE DRAWINGS

FIG. 1 is an illustration showing a schematic configuration of a remote-control system of the present invention;

FIG. 2 is a perspective view of the front-side appearance of a transmitter;

FIG. 3 is a back view of a transmitter;

FIG. 4 is a sectional view of a concave portion formed at the front side of a transmitter;

FIG. 5 is a functional block diagram of a transmitter;

FIGS. 6A and 6B are illustrations showing states of transmitting data from transmitters;

FIG. 7 is an illustration showing an electric-train model as an example of a drive;

FIG. 8 is a functional block diagram of an electric-train model;

FIG. 9 is a flowchart showing the processing for a transmitter to transmit data;

FIG. 10 is a flowchart showing the processing for a drive to receive data;

FIGS. 11A and 11B are illustrations showing relations between transmitters and drives corresponding to identification-information set states; and

FIGS. 12A and 12B are illustrations showing other relations between transmitters and drives corresponding to identification-information set states.

DESCRIPTION OF THE PREFERRED EMBODIMENT

FIG. 1 is an illustration showing a schematic configuration of a remote control system of the present invention. In FIG. 1, a case is assumed in which six drives 1 . . . 1 are separately remote-controlled by three transmitters 2 . . . 2 at the same place.

Any one of the ID codes 1 to 4 is set to the drives 1 . . . 1 and transmitters 2 . . . 2 as transmitter-specifying information and any one of the car numbers 1 to 8 is set to the drives 1 . . . 1 and transmitters 2 . . . 2 as drive-specifying information. In the case of this embodiment, a combination between an ID code and a car number functions as the identification information for relating the transmitter 2 with the drive 1. Infrared radiation is used for remote control of each drive 1. Therefore, a remote-control-signal light-emitting section 3 is mounted on each transmitter 2 and a remote-control-signal light-receiving section 4 is mounted on each drive 1. Moreover, a remote-control-signal light-receiving section 5 is mounted on each transmitter 2 in order to synchronize data transmission from each transmitter 2.

FIGS. 2 and 3 show details of the transmitter 2, in which FIG. 2 is a perspective view of the transmitter 2 viewed from the front side (user side) and FIG. 3 is a back view of the transmitter 2. As shown in these illustrations, the transmitter 2 has a casing 21 formed of a resin and the like. A light-emitting section 22 (corresponding to a remote-control-signal light-emitting section 3 in FIG. 1) for transmitting data to the drive 1 is set on the back 21a of the casing 21 and a light-emitting section 23 for transmitting the data for rewriting the identification information for the drive 1 is set at the front 21b of the casing 21. A cover 21c allowing infrared radiation to pass therethrough is set to the back 21a and the light-emitting section 23 is set to the inside of the cover 21c. Moreover, light-receiving sections 25 and 25 serving as the remote-control-signal light-receiving section 5 in FIG. 1 are set to the inside of the cover 21c. The transmission-destination area (arrival area) of infrared radiation from the light-emitting section 22 is set in a predeter-

mined angle range and a predetermined distance range at the back-21a side and the transmission-destination area of infrared radiation from the light-emitting section 23 is set in a predetermined angle range and a predetermined distance range at the front-21b side. Therefore, transmission-destination areas of infrared radiation of the light-emitting sections 22 and 23 are different from each other.

As shown also in FIG. 4, a concave portion 21d is formed at the front 21b of the casing 21 and covered by a lid 24. The lid 24 can be opened to the front side about a hinge 24a at the bottom end of the lid 24. The lid 24 is made of a material capable of cutting off infrared radiation. The light-emitting section 23 is set to the face of the wall of the concave portion 21d. Charge terminals 33a and 33b are set on the bottom face of the concave portion 21d. These terminals 33a and 33b contact with a charge terminal of an electric-train model 50 (refer to FIG. 7) serving as the drive 1 housed in the concave portion 21d to charge a battery built in the electric-train model 50.

According to the above transmitter 2, it is possible to prevent the infrared radiation emitted from the light-emitting section 23 from leaking to the outside of the concave portion 21d by housing the drive 1 in the concave portion 21d and closing the lid 24. Therefore, it is possible to eliminate a fear that identification information for the drive 1 outside of the concave portion 21d is carelessly rewritten.

As shown in FIG. 2, an F/R switch 26 to be operated to switch forward and reverse rotations of the drive 1, a speed control dial 27 to be operated to set a speed, a rewrite control switch 28 to be operated to designate rewriting of identification information for the drive 1, an ID-code-setting switch 29 for setting an ID code of the transmitter 2, car-number selection switches 30 . . . 30 for designating car-number, a power-source switch 31, and a charge switch 32 are set to the upper face 21e of the casing 21 as an input unit 10.

The F/R switch 26 can be switched to forward-rotation position or reverse-rotation position and it outputs signals corresponding to these positions. The speed control dial 27 outputs a speed designation signal proportional to a rotation control amount from the initial position corresponding to the speed 0. The rewrite control switch 28 is a push-button switch that outputs an on-signal when it is pushed. The ID-code setting switch 29 can be switched at four positions corresponding to ID codes 1 to 4 and it outputs signals corresponding to these positions. By switching the ID-code setting switch 29, it is possible to select an ID of the transmitter 2 among IDs 1 to 4. The car-number selection switch 30 is a push-button switch that outputs an on-signal corresponding to a push control. Eight car-number selection switches 30 are provided correspondingly to car numbers 1 to 8 by one to one. By pushing any one of the car-number selection switches 30, it is possible to select a car number corresponding to the selected car-number selection switch 30.

FIG. 5 shows a circuit configuration of the transmitter 2. Signals corresponding to operations of input units 26 to 30 are input to a control circuit 41 through an input circuit 40. The remote-control-signal light-emitting sections 22 and 23 are respectively constituted by including light-emitting device such as an LED and emit infrared radiation corresponding to a designation by a transmission circuit 42 or 43. The transmission circuits 42 and 43 output transmission data to the remote-control-signal light-emitting section 22 or 23 in accordance with the timing designated by an output-timing generation circuit 44. The output-timing generation circuit 44 counts time in accordance with a timer set value supplied from the control circuit 41. When the time corre-

sponding to the timer set value elapses, the circuit 44 outputs a transmission designation to the transmission circuit 42 or 43. Frequencies of infrared-radiation carrier signals output from the remote-control-signal light-emitting sections 22 and 23 are the same in all transmitters 2.

Data to be output to the remote-control-signal light-emitting section 22 on the back 21a of the transmitter 2 is generated by the control-signal generation circuit 45. The transmission circuit 42 modulates the data generated by the control-signal generation circuit 45 in accordance with a remote-control-signal carrier signal to drive the remote-control-signal light-emitting section 22.

In this case, one-block remote-control data generated by the control-signal generation circuit 45 is constituted by an ID code, motor control information, a car number, and a command for realizing an additional function as shown in FIG. 6A. Moreover, the motor control information is constituted by information for designating whether forward direction or reverse direction (F/R determination) of the rotational direction of a motor and information for designating a motor-driving speed. Two-bit data corresponding to an ID code selected by the ID-code setting switch 29 is set to the ID-code part, one-bit data showing whether the F/R switch 26 is set to forward-rotation position or reverse-rotation position is set to the F/R-discriminating part of a motor, and five-bit data for designating a speed corresponding to a rotation control amount of the speed control dial 27 is set to the motor control information part. Three-bit data for designating any one of car numbers 1 to 8 selected by the car-number selection switch 30 is set to the car-number part. The command part is constituted by a predetermined number of bits and a code for designating an additional function is set to the command part according to necessity. The number of bits of the one-block remote-control data is always constant. Therefore, the time required to transmit the one-block remote-control data is also constant.

The remote-control-signal light-receiving section 25 shown in FIG. 5 receives the infrared radiation sent from another transmitter 2 and outputs a signal obtained by removing carrier components from the received infrared radiation to a reception circuit 47. The reception circuit 47 decodes a signal supplied from the remote-control-signal light-receiving section 25 into one-block remote-control data and outputs the data to a received-data discrimination circuit 48.

The received-data discrimination circuit 48 discriminates the ID code of the received data supplied from the reception circuit 47 and supplies the determination result to the control circuit 41. The control circuit 41 controls the output timing of the data supplied from the transmission circuit 42 in accordance with signals supplied from the received-data discrimination circuit 48 and input circuit 40. Thus, the data transmitted from another transmitter 2 is received to set the output timing of the data in order to prevent interference due to simultaneous transmission of remote-control data from a plurality of transmitters 2. This point is described below in detail.

FIG. 6A shows how to take the transmission timing when four transmitters 2 are simultaneously operated. As shown in FIG. 6A, infrared-radiation emission timings from the remote-control-signal light-emitting section 22 are set to periods different from each other in accordance with ID codes set to the transmitter 2 and the drive 1 to be controlled by the transmitter 2 in common.

The time length for one transmitter 2 to transmit a remote-control signal is equal to T and each transmitter 2 repeats transmission of a remote-control signal at a cycle

corresponding to the number of transmitters 2×transmission time length (=4T). Moreover, the transmission timing of each transmitter 2 is shifted every T from ID code=1 in order. Because each transmitter 2 controls transmission timing in accordance with the above relation, it is possible to prevent transmission periods of four transmitters 2 from overlapping with each other. To realize the above transmission control, it is allowed for the transmitter 2 of ID code=2 in FIG. 6A to control transmission timing as described below.

First, when receiving the data of ID code=1 at the time t1, the transmitter 2 starts outputting the transmission data of its own and completes outputting the transmission data of its own at the time t2. When completing the transmission, the transmitter 2 checks the data received by the reception circuit 47 (refer to FIG. 5) to confirm that interference between signals does not occur. Thereafter, the transmitter 2 sets a transmission timer for counting the next output timing 3T later to start timer counting.

When receiving the remote-control data of ID code=3 at the time t3, the transmitter 2 resets the transmission timer 2T later to start timer counting. When receiving the remote-control data of ID code=4 at the time t4, the transmitter 2 resets the transmission timer 1T later to start timer counting.

Then, when the power source of the transmitter 2 of ID code=1 is turned off or data cannot be received from the transmitter 2 of ID code=1 due to noises, it is allowed to start outputting the data of its own when counting by the transmission timer advances by the time T after receiving the data of ID code=4. Moreover, even if signals from another transmitter 2 cannot be received, it is possible to continue outputting transmission data at the cycle 4T by using the time 3T set to the transmission timer when transmission of the data of its own is completed.

Though a case of using four transmitters 2 is described above, it is possible to control transmission timing even in the case of five transmitters or more by adding an ID code. The cycle of transmission timing of each transmitter 2 is equal to N×T (N denotes the number of transmitters). Moreover, it is allowed to set the entire cycle to a value larger than NT by setting a blank period in which no transmitter transmits data between periods in which transmitters 2 transmit data.

The transmission timing of the data sent from the light-emitting section 23 in FIG. 5 is consecutively set as shown in FIG. 6B (three consecutive times in the case of this example). The data to be output to the remote-control-signal light-emitting section 23 at the front 21b of the transmitter 2 is generated by an identification-information-rewrite-signal generation circuit 46 and the transmission circuit 43 drives the remote-control-signal light-emitting section 23 by modulating the data generated by the identification-information-rewrite-signal generation circuit 46 in accordance with a remote-control-signal carrier signal. The data generated by the identification-information-rewrite-signal generation circuit 46 has the same structure as that generated by the control-signal generation circuit 45 as shown in FIG. 6B. However, a specific code for designating rewriting of the ID code and car number of the drive 1 (hereafter referred to as rewrite designation code) is set to the command part of the above data as change-designating information. That is, in the case of this embodiment, data is transmitted from the remote-control-signal light-emitting section 23 through the control circuit 41, identification-information-rewrite-signal generation circuit 46, and transmission circuit 47 only when designating change of ID codes and car numbers from the transmitter 2 to the drive 1.

The control circuit **41** discriminates whether to transmit the data for operation control of the drive **1** or the data for change of identification information depending on the fact that the rewrite control switch **28** is turned on or not and supplies signals corresponding to operation states of the input units **26** to **30** to the control-signal generation circuit **45** when transmitting the data for operation control of the drive **1** and to the identification-information-rewrite-signal generation circuit **46** when transmitting the data for designating change of identification information. When the control-signal generation circuit **45** receives a signal, remote-control data for control of the drive **1** is generated correspondingly to operation states of the input units **26** to **30**. When the identification-information-rewrite-signal generation circuit **46** receives a signal, remote-control data for change of the identification information for the drive **1** is generated correspondingly to operation states of the input units **28** to **30**.

It is also allowed to communize the generation circuits **45** and **46** and alternatively transmit data from either of the remote-control-signal light-emitting sections **22** and **23** depending on the fact that the rewrite control switch **28** is turned on or not. In this case, for an ID code, motor control information, and a car number in one-block remote-control data, it is allowed to always set the data corresponding to operation states of the ID-code setting switch **29**, F/R switch **26**, speed control dial **27**, and car-number selection switch **30** independently of the fact that the rewrite control switch **28** is turned on or not, set a rewrite designation code to the command part to transmit data from the remote-control-signal light-emitting section **23** only when the rewrite control switch **28** is turned on, and transmit data from the remote-control-signal light-emitting section **22** when controlling operations of the drive **1**. Moreover, it is allowed to communize the remote-control-signal light-emitting sections **22** and **23** and transmit the data for operation control of the drive **1** and identification-information-rewriting data from the same light-emitting section.

The control circuit **41** is preferably constituted by combining a microcomputer with a predetermined program. It is allowed to constitute the transmission circuits **42** and **43**, output-timing generation circuit **44**, control-signal generation circuit **45**, identification-information-rewrite-signal generation circuit **46**, reception circuit **47**, and received-data discrimination circuit **48** as logic circuits or constitute them by combining a microcomputer with a predetermined program similarly to the case of the control circuit **41**. Moreover, it is allowed to unite at least one of the output-timing generation circuit **44**, control-signal generation circuit **45**, identification-information-rewrite-signal generation circuit **46**, and received-data discrimination circuit **48** into the control circuit **41**.

FIG. 7 is a side view showing an embodiment of the drive **1**. In the case of this embodiment, the drive **1** is constituted as the small electric-train model **50**. The electric-train model **50** has a chassis **51** and a body **52** put on the chassis **51**. Front wheels **53** are provided for the front of the chassis **51** and rear wheels **54** are provided for the rear of the chassis **51**. The front wheel **53** is rotatably set to the chassis **51** through a wheel shaft **55**. The rear wheel **54** is set to a transmission gear **57** through the wheel **56**. The transmission gear **57** transmits the rotation of a motor **58** serving as a driving source to a wheel shaft **56**. A controller **59** constituted as a one-chip microcomputer is set above the transmission gear **57** and motor **58**. The controller **59** controls

operations of the motor **58** in accordance with the data sent from a remote-control-signal light-receiving section **60** set to the body **52**.

FIG. 8 shows a circuit configuration of a control system mounted on the electric-train model **50**. The above remote-control-signal light-receiving section **60** is set to the car model **50**. The remote-control-signal light-receiving section **60** receives the infrared radiation emitted from the transmitter **2** and outputs a signal obtained by removing carrier components from the received infrared radiation to a reception circuit **71**. The reception circuit **71** decodes the signal supplied from the remote-control-signal light-receiving section **60** into one-block remote-control data and outputs the data to a remote-control-data discrimination circuit **72**. The one-block remote-control data is shown in FIGS. 6A and 6B. The remote-control-data discrimination circuit **72** discriminates which is received, the data for controlling operations of the drive **1** or the data for designating rewriting (changing) of the identification information for the drive **1**, in accordance with command part of the received data supplied from the reception circuit **71**.

When the remote-control-data discrimination circuit **72** discriminates that the received data is the data for controlling operations of the drive **1**, an identification-information read circuit **77** reads the identification information assigned to the drive **1** itself from an identification-information storage memory **78** and an identification-information discrimination circuit **73** compares the identification information included in received data with the identification information for the drive **1** itself. When these pieces of identification information coincide with each other, the received data is sent to a driving-section control circuit **74**. Then, the driving-section control circuit **74** supplies a motor-driving signal to a driving circuit **75** in accordance with the motor control information included in the received data. The driving circuit **75** drives the motor **58** in accordance with the supplied motor-driving signal.

When the remote-control-data discrimination circuit **72** discriminates that received data is the data for designating rewriting of identification information, the identification information (comprising an ID code and a car number) included in the data is written in the identification-information storage memory **78** by the identification-information rewrite circuit **76**. Thereby, the identification information written in the identification-information storage memory **78** is changed.

It is preferable that identification information is stored in the identification-information storage memory **78** without backup by a power source by using a nonvolatile memory such as an EEPROM. It is allowed to constitute the reception circuit **71**, remote-control-data discrimination circuit **72**, identification-information discrimination circuit **73**, driving-section control circuit **74**, driving circuit **75**, identification-information rewrite circuit **76**, and identification-information read circuit **77** as logic circuits or by combining a microcomputer with a predetermined program. Moreover, it is allowed to set an identification-information discrimination circuit, an identification-information read circuit, and an identification-information storage memory different from the identification-information discrimination circuit **73**, identification-information read circuit **77**, and identification-information storage memory **78** between the reception circuit **71** and remote-control-data discrimination circuit **72** and select received data before sending data to the remote-control-data discrimination circuit **72**.

FIG. 9 is a flowchart showing operations of the transmitter **2** when transmitting data. Under the normal state, the

transmitter 2 repeats data transmission at the timing shown in FIG. 6A and the processing in FIG. 9 is performed when the next transmission timing comes. In the case of this processing, the transmitter 2 first decides whether the rewrite control switch 28 is turned on or not (whether the switch 28 is pushed or not) (step S1). When the transmitter 2 decides that the switch 28 is not turned on, it generates the data for controlling operations of the motor 58 in accordance with the operation state of the F/R switch 26 or the like and transmits the data from the light-emitting section 22 (step S2). When the transmitter 2 decides that the rewrite control switch 28 is turned on, it generates the data for designating rewriting to the identification information set by the ID-code setting switch 29 and car-number selection switch 30 and transmits the data from the light-emitting section 23 at the front side (step S3). Then, the transmitter 2 adds 1 to a counter serving as a variable for measuring the number of consecutive transmission times of rewrite designation data (step S4) and then, decides whether the rewrite control switch 28 is continuously turned on or not (step S5). When the switch 28 is turned on, the transmitter 2 decides whether the counted value of the counter reaches 3 (step S6). When the value is less than 3, the transmitter 2 returns to step S3 to retransmit the identification-information rewrite designation data. When the transmitter 2 decides in step S5 that the rewrite control switch 28 is turned off or decides in step S6 that the counted value reaches 3, it completes the processing in FIG. 9.

According to the above processing, when a user continuously pushes the rewrite control switch 28, the data for designating rewriting of identification information is transmitted from the light-emitting section 23 by three consecutive frames as shown in FIG. 6B. However, in the case other than the above, the data for drive controlling the motor 58 is transmitted from the light-emitting section 22.

FIG. 10 is a flowchart showing the reception processing to be executed by the controller 59 of the electric-train model 50 serving as a drive when the controller 59 receives data from the transmitter 2. The controller 59 analyzes a command part included in received data to discriminate whether the received data is the data for controlling operations of the motor 58 or not (step S11). For example, the controller 59 decides the received data as the data for controlling operations of the motor 58 when a specific code for realizing a specific function is not set to the command part. Moreover, when generating the data for controlling operations of the motor 58 by the transmitter 2, it is allowed to include a specific code for designating the data for operation control in the command part and determine the data for operation control of the motor 58 or not depending on presence or absence of the specific code.

When the controller 59 decides that the received data is the data for controlling operations of the motor 58, it discriminates whether the ID code included in the data is the same as the ID code of its own recorded in the identification-information storage memory 78 (step S12). When the ID code included in the data is different from the ID code of its own, the controller 59 ignores the data and temporarily ends the processing in FIG. 10. In this case, the controller 59 waits for the next data to be received.

When the ID code included in the data is the same as the ID code of the self, the controller 59 decides whether the car number included in the data is the same as the car number of its own stored in the identification-information storage memory 78 (step S13). When the car number included in the data is different from the car number of the train model 50 itself, the controller 59 ignores the data and waits for the

next data to be received. When the car number included in the data is the same as the car number of the train model 50 itself, the controller 59 controls the motor 58 in accordance with the control information included in the data (step S14) and then, waits for the next data to be received.

When the controller 59 decides that the received data is not the data for controlling operations of the motor 58 in step S11, it decides whether a rewrite designation code is included in the command part or not (step S15). When the rewrite designation code is not included, the controller 59 resets a counter for discriminating a consecutive number of reception times of rewrite designation codes to 0 (step S20) and waits for the next data to be received. When the rewrite designation code is included, the controller 59 adds 1 to the counter (step S16) and decides whether a counted value reaches 3 or not, that is, whether the remote-control data including the rewrite designation code is received three times or not (step S17). When the counted value does not reach 3, waits for the next remote-control data to be received, when the counted value does reach 3, the controller 59 rewrites the ID code and car number recorded in the identification-information storage memory 78 to the ID code and car number included in the data received at that point of time (step S18). Thereafter, the controller 59 resets the counter to 0 (step S19) and waits for the next data to be received.

According to the above processing, ID codes and car numbers are changed when the electric-train model 50 serving as a drive receives the remote-control data including a rewrite designation code three times consecutively and operations of the motor 58 are controlled in accordance with motor control information only when the ID code and car number included in the data for driving the motor 58 coincide with each other when the data is received.

In the case of the above embodiment, ID codes and car numbers are simultaneously changed. However, it is also allowed to separately perform change of ID codes and change of car numbers by separately generating a command for changing ID codes and a command for changing car numbers. Moreover, it is allowed to first compare the ID code in received data with the ID code set to a drive (step S12) and then decide a command (step S11) so that car numbers of only a drive to which the ID code same as that of a transmitter is set can be changed. Furthermore, though a case is described in which identification information is changed when receiving identification-information-change designation data three times consecutively, it is allowed to change the identification information when receiving the data once or three times or more.

FIGS. 11A and 11B and FIGS. 12A and 12B illustrate operation states when two transmitters and two drives are used. In FIG. 11A, the transmitter A can control the drive A having the same an ID code and a car number as its own. But the transmitter B can control neither drive A nor drive B. By transmitting identification-information change data from the transmitter B to the drive B (FIG. 11B), the identification information for the drive B is changed to the identification information for the transmitter B (FIG. 12A). As a result, the transmitters A and B can respectively control a drive having the same identification information as the information for its own (FIG. 12B).

The present invention is not restricted to the above embodiment but it can be embodied by various embodiments. For example, a drive is not restricted to a train but it can use any one of embodiments simulating various movable bodies. A transmitter can use a portable type or fixed type. Moreover, it is allowed to use a portable unit such as

a portable game machine or portable telephone as a transmitter by installing a specific program in the game machine or portable telephone.

A drive is not restricted to a unit simulating a train but it is allowed to include various units. It is allowed to control sections different from each other of an integrally constituted toy or model as drives different from each other.

As described above, according to the present invention, the data for controlling operations of a drive and the data for changing the identification information for the drive are output from the first and second transmission sections toward areas different from each other. Therefore, when a plurality of drives are used, it is possible to change the identification information for the drives by arranging some of the drives in an area to which the first transmission section is turned while arranging other drives in an area to which the second transmission section is turned and thus, the fear disappears that identification-information-change data reaches a drive whose operations are controlled in accordance with the data sent from the first transmission section and the identification information for the drive is changed on the contrary to the intention of a user while the identification information of another drive is changed. Thereby, it is possible to provide a transmitter suitable for a remote-control system making it possible to change the identification information for a drive in accordance with the data sent from a transmitter.

What is claimed is:

1. A transmitter used for a remote-control system, the system being capable of separately controlling a plurality of drives, the transmitter comprising:

an input unit for accepting identification information of one of a plurality of possibilities for transmission to and storage in a drive of the plurality of drives, command information for effecting rewriting of the identification information in the, and drive control information for operating the drive;

a data generation device for alternatively generating operating data including the identification information and the drive control information for controlling operations of the drive or rewriting data including the identification information for changing the identification information for the drive in accordance with operations of the input unit performed by a user and the command information;

a transmission device including a first transmission section and a second transmission section whose transmission-destination areas are different from each other and capable of transmitting the data generated through the data generation device from the first and second transmission sections; and

a transmission-section change device for setting which of the first and second transmission sections from which the data is transmitted in accordance with whether the operating data or the rewriting data is generated by the data generation device so that the operating data for controlling operations of the drive will be transmitted from the first transmission section and the rewriting data for changing the identification information for the drive will be transmitted from the second transmission section.

2. The transmitter according to claim 1, wherein the second transmission section is provided on a front side of a casing of the transmitter, while the first transmission section is provided on a back side thereof, when the transmitter is viewed from the user.

3. The transmitter according to claim 1, wherein a concave portion capable of housing the drive is formed in a transmitter casing and the second transmission section is provided in the concave portion such that the rewriting data is transmitted to the drive when the drive is in the concave portion.

4. The transmitter according to claim 3, wherein the concave portion has a lid for closing the concave portion while housing the drives.

5. The transmitter according to claim 3, wherein charge terminals for charging a power-source battery of the drive are provided in the concave portion such that charging is effected while the rewriting data is transmitted to the drive when the drive is in the concave portion.

6. The transmitter according to claim 1, wherein the first and second transmission sections serve as infrared-radiation-emitting sections.

7. The transmitter according to claim 4, wherein the second transmission section is an infrared-radiation-emitting section and the lid blocks infrared transmissions.

8. The transmitter according to claim 4, wherein charge terminals for charging a power-source battery of the drive are provided in the concave portion such that charging is effected while the rewriting data is transmitted to the drive when the drive is in the concave portion.

9. The transmitter according to claim 8, wherein the second transmission section is an infrared-radiation-emitting section and the lid blocks infrared transmissions.

10. The transmitter according to claim 1, wherein the operating data and the rewriting data each commonly formatted to include sections for accommodating the identification information, the drive control information, and the command information and the command information indicates whether data storage is to be effected.

* * * * *