



(22) Date de dépôt/Filing Date: 2003/12/31

(41) Mise à la disp. pub./Open to Public Insp.: 2005/06/30

(51) Cl.Int.⁷/Int.Cl.⁷ F03D 3/00, F03D 11/00

(71) Demandeur/Applicant:
JOHNSON, BUD T. J., CA

(72) Inventeur/Inventor:
JOHNSON, BUD T. J., CA

(54) Titre : CONFIGURATION DE MOTEUR A TURBINE-ROTOR HORIZONTAL ACTIONNES PAR L'ENERGIE EOLIENNE

(54) Title: WIND POWERED TURBINE ENGINE-HORIZONTAL ROTOR CONFIGURATION

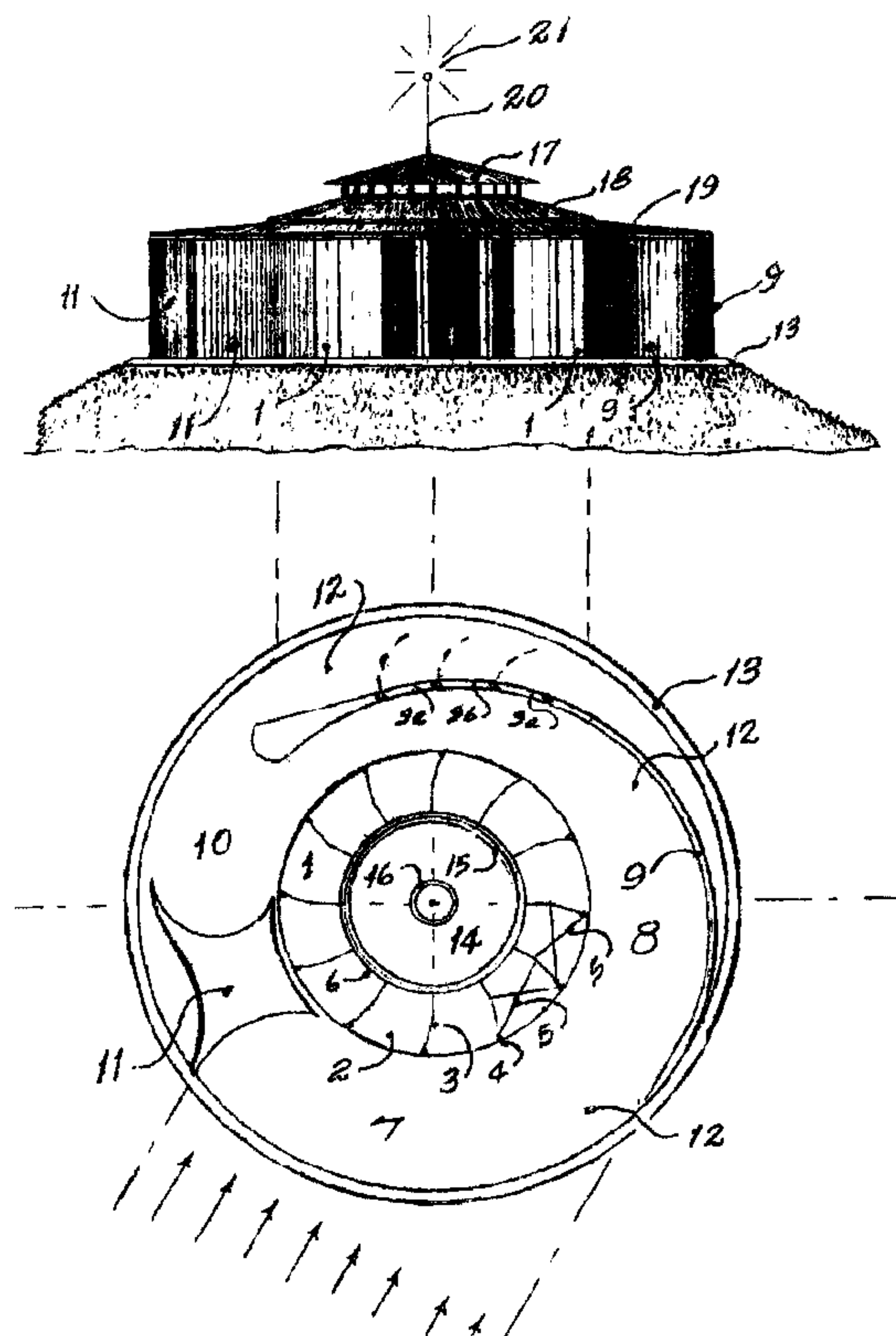

(57) Abrégé/Abstract:

This invention changes the nature of what would usually be referred to as wind turbines. It has an internalized containment and control chamber, to more specifically access a maximum of energy throughput, similar to a gas or steam turbine engine. With intake enhancement, velocity increase, compression, and a vacuum induction exhaust port, this invention functions the same as a steam or gas turbine engine, but without the heat. It will have greater efficiency and net energy output than present state of the art

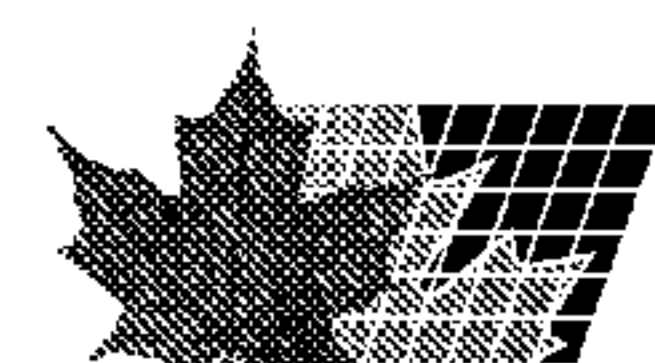

(57) **Abrégé(suite)/Abstract(continued):**

wind turbines for all of those reasons. It will also be able to provide useful levels of energy output at lower wind speeds, and will continue to harness wind energy at much higher wind speed than the 3-bladed wind turbines which are present state of the art. Sudden variations in wind speed are more easily tolerated, than with present state of the art wind turbines. Means of increasing available kinetic energy in a moving mass of air, as applied in this invention, are referred to by the inventor as kinetic energy enhancement. This presently preferred version is of a carousel configuration, with its rotor turning horizontally, parallel to the ground. In this configuration, it does not have size limitations usual to present state of the art propeller type wind turbines. It is expected to have a particular advantage as to "economics of scale", where this invention, built as a unit of larger size, could have double the electrical generating capacity of the largest propeller type wind turbines of present state of the art.

WIND POWERED TURBINE ENGINE Horizontal Rotor Configuration

Bud T. J. Johnson
#17, 918 – 16th. Ave. N.W.
Calgary, Alberta, Canada
T2M OK3
A Canadian Citizen

ABSTRACT

This invention changes the nature of what would usually be referred to as wind turbines. It has an internalized containment and control chamber, to more specifically access a maximum of energy throughput, similar to a gas or steam turbine engine. With intake enhancement, velocity increase, compression, and a vacuum induction exhaust port, this invention functions the same as a steam or gas turbine engine, but without the heat. It will have greater efficiency and net energy output than present state of the art wind turbines for all of those reasons. It will also be able to provide useful levels of energy output at lower wind speeds, and will continue to harness wind energy at much higher wind speed than the 3-bladed wind turbines which are present state of the art. Sudden variations in wind speed are more easily tolerated, than with present state of the art wind turbines. Means of increasing available kinetic energy in a moving mass of air, as applied in this invention, are referred to by the inventor as kinetic energy enhancement. This presently preferred version is of a carousel configuration, with its rotor turning horizontally, parallel to the ground. In this configuration, it does not have size limitations usual to present state of the art propeller type wind turbines. It is expected to have a particular advantage as to "economics of scale", where this invention, built as a unit of larger size, could have double the electrical generating capacity of the largest propeller type wind turbines of present state of the art.

- 2 -

BACKGROUND OF THE INVENTION

The inventor has studied examples of present state of the art wind turbines of the propeller type. It was apparent that with present state of the art wind turbines, certain improvements are necessary to capture and harness a higher percentage of energy from a given cross section of wind accessed by their propeller blades. It was also becoming quite apparent that present propeller types of wind turbines are reaching the upper limit of their size range. Economics of scale in their case, is to build and install large numbers of them. Land use, low frequency high intensity sound, with regard to animals, and aesthetic appearance, were other important considerations.

OBJECTS OF THE INVENTION

It had occurred to the inventor that successful attainment of the following objects would lead to the harnessing of a higher percentage of wind energy by wind turbines. The first would be an enlarged intake area in front of the turbine rotor. The second would be a containment and control chamber to assure maximum energy recovery from the captured wind. The third would be a means of increasing wind throughput velocity beyond prevailing wind speed as faced by the turbine unit. The fourth would be a means of compressing wind throughput. The fifth would be an exhaust area of lower atmospheric pressure. Placement, embodiment, enclosure and appearance also needed to be addressed, toward a completed unit package less imposing to the landscape, and less bothersome to birds and animals.

BASIC DESCRIPTION AND IMPROVEMENTS OVER PRESENT STATE OF THE ART

This invention harnesses wind energy by means of an internalized rotor, which has its blades situated at a comparatively long radius from its center. In this preferred embodiment, its blades are within the outer 40% of the radius of its rotor. That feature contributes to

- 3 -

increased torque. Intake wind displaced by the blocked off inner 60% of the radius of its turbine rotor, is redirected to drive its blades, rather than becoming wasted energy. Also, this invention channels and increases the velocity of incoming wind, through a controlled chamber containing its turbine rotor, increasing wind compression as it drives the turbine blades, much the same as the functions of a steam or gas turbine engine. Controlled containment and direction of incoming energy, guided toward maximum thrust against turbine blades does result in a significant increase in captured energy. Gas and steam turbine engines are clear examples of the successful application of those principles.

A novel feature of this invention is its wind intake and throughput channel, which curves incoming wind by as much as one hundred and eighty degrees. This feature achieves three things in particular. Firstly, it increases throughput wind velocity. Secondly, its radius is progressively decreasing from the center of the turbine rotor, compressing incoming wind, increasing its density, and enhancing its ability to drive the rotor blades. Thirdly, it causes the wind throughput to constantly drive eight of twelve rotor blades, or two thirds of any number of blades one might place on the turbine rotor.

Theoretically, the potential amount of wind speed increase, as oncoming wind passes through the wind intake and throughput channel of this invention, would be based on $\frac{1}{2} C$ over D (one half of the circumference of a full circle as would be defined by continuing the inner facing surface of the said throughput channel to form a full circle, divided by the diameter of that circle), and that figure comes to 1.57 to 1. However, usual drag factors, and some potential slow down related to compression will reduce that velocity increase quite significantly, perhaps by more than 25%. Nevertheless, any net increase in velocity of the oncoming air mass is going to increase available kinetic energy (watts per square meter) in cubic terms. A net wind speed increase of 25% would increase the available wattage per square meter by 1.25 cubed, or 1.95, and a 95% increase in available energy could be the end result. A 50% net increase in wind speed would increase available wattage by 1.50 cubed, or 3.375, and that becomes very significant.

With regard to a compression factor, that will also improve available kinetic energy per square meter. An increase in the mass or weight of

- 4 -

the oncoming air mass is also a cubic function, as we calculate available wattage per square meter, and as with the velocity increase, a 25% compression factor could increase our available wattage per square meter by 95%.

The inventor refers to the above-mentioned means of velocity increase and creating compression as Kinetic Energy Enhancement, and further suggests that phrase should become common terminology for such means of increasing recoverable energy potential for wind power units.

With this invention, we now have a wind turbine engine, with an enlarged induction or intake area, followed by velocity increase and compression, within a chamber containing its turbine rotor, and with its wind throughput being ejected or exhausted into an area of lower pressure. Reduced pressure in the exhaust area is enhanced by means of controlled curvature and exhaust chamber shape.

Reduction in exhaust pressure is further enhanced by means of a wind bypass airfoil on the exterior wall of the turbine housing structure, which increases wind speed to provide an area of lower pressure (induction) at the outside periphery of the exhaust chamber exit port.

Another gainful feature is an air scoop curve on the left front side of the turbine intake area, which redirects and speeds up an enlarged area of incoming wind, toward more directly addressing the rotor blades, and increasing wind pressure in the direction of rotation.

This invention has an advantage, where present state of the art three bladed propeller types of wind turbines are reaching their upper limits of scale. This invention can be built to a large scale to generate a greater amount of electrical energy than the largest three bladed wind turbines of present state of the art. Capital cost per megawatt of electrical energy generated would be significantly reduced.

The inventor has designed a version of this invention, where its turbine rotor is 100 feet (30.48 meters) in diameter, with each of its blades being 800 square feet (74.32 square meters) in size. With eight of its twelve blades being driven at the same time, the wind is driving 6,400 square feet (595 square meters) of blade area. A very

- 5 -

large amount of torque and useable horsepower would be produced, toward driving electrical generators, or any other mechanical means of harnessing such power output. This invention may be built to any scale which measures its cost against the value of its production of useable energy, within the limitations of proper engineering and available structural materials.

With regard to sudden changes in wind speed, which may have an adverse effect on present state of the art wind turbines, the compression area of this invention will tend to absorb such variations with no damage to the turbine, or to the outer boundary wall of its wind throughput channel. (The said outer boundary wall must be properly reinforced to accommodate such surges and pressure.) It may be further noted that a 100 foot (30.48 meter) diameter rotor would be rotating at only about 20 revolutions per minute, with wind going through its wind throughput channel at seventy miles (112.65 kilometers) per hour, assuming the speed of the outer circumference of the rotor to be the same as the wind speed.

The largest three bladed propeller wind turbines of present state of the art stand as high as three hundred feet (91.44 meters) above the ground, when measured from ground level to the top of the circumference of their blade tip path of rotation. This invention, of carousel configuration, with a single 100 foot (30.48 meter) diameter rotor, would stand about 100 feet high (30.48 meters) from ground level to its rooftop, with its floor level being thirty feet (9.144 meters) above ground level. It would be far less than half the height of the largest three bladed propeller turbine, which is present state of the art.

Aesthetically and environmentally, this invention may appear more desirable than present state of the art wind turbines. It will present an aesthetically unimposing profile, which should blend more easily with the environment. Its ground base mound can be seeded to grass, and its containment structure may look attractive. In the matter of damage to birds in particular, that is quite unlikely at any time. They could simply fly through its wind throughput channel, increasing their speed on the way through. Another problem locally characteristic of large three bladed wind turbines is high intensity low frequency

- 6 -

sound. This invention is unlikely to create such a sound problem, and it may not be a bothersome or limiting challenge to apply sound abatement to its type of shape and structure if that should become necessary.

The inventor readily expects that smaller models of this invention could be placed on the roof of a building, or on a framework or tower, to capture wind energy for specific needs. Smaller models are also envisioned, with their turbine rotor mounted on a horizontal axle.

Variations in the scooped, curved or segmented nature of its turbine rotor blades, and further input, throughput and aperture enhancements are also envisioned by the inventor, and such modifications would become obvious to anyone skilled in the art.

The inventor's further general comments with regard to the subject invention are that he has in this case, simply invented a wind turbine engine, as a straightforward concept. Further details beyond those presented herein, concerning floor rotation, rotor bearings, Mechanicals, power transmission drives and systems are all presently known and readily available, either as clearly defined concepts or available products on the market. Those items as may be considered essential to this invention are considered to be matters of mechanical engineering, or the properly engineered use of state of the art technology.

DETAILED DESCRIPTION

Figure 1 is a vertical floor plan view of a preferred embodiment of the invention. It is anticipated that a floor plan and rotor reversal might be in order in some situations.

Figure 2 is a frontal view of the same embodiment, more completely illustrating its wind capture aperture and relative rotor placement, as it would appear in operating mode, fully assembled on site, within its building enclosure, with wind capture aperture set to full operating position, as shown in figure 1.

- 7 -

With all of the foregoing in view, and such other and further purposes, advantages or novel features as may become apparent from consideration of this disclosure and specification, the present invention consists of the inventive concept which is comprised, embodied, embraced or included in various specific embodiments of such concept, reference being made to the accompanying figures, in which:

Figure 1 is a vertical floor plan view of a preferred embodiment of the subject invention, where turbine rotor assembly 1, consists of flat, circular base plate 2, at its bottom, and another of the same at its top (not shown), turbine blades 3, with progressive slight bends, to produce a partial scoop effect, blade strength, and stability, and may further provide added surface tension to the rotor blades, as may be desirable in this type of arrangement. Then we have blade tip reinforcement strips or pieces 4, and reinforcement tubes or cables 5, cylindrical turbine rotor axle tube 6, wind intake aperture area 7, wind flow and compression channel 8, outer boundary containment wall 9, with higher strength ejection end for pressure containment, which is curved to increase ejection velocity and reduce exiting wind pressure. Outer boundary containment wall 9, has three short sections thereof, 9a, 9b and 9c, which may be opened from partially to completely open, for the purpose of reducing wind compression which may become too great for the said wall 9, to tolerate, such as in the case of very high wind speeds, when we want to continue to harness the wind energy, without damaging the turbine housing structure. Then we have lower pressure wind ejection area 10, with its function further augmented by the rear curved face of wind barrier and flow guide assembly 11, which also has a curved front side to speed up, direct and partially compress incoming wind against turbine blades 3, in wind intake aperture area 7, and further, with its left side compound airfoil curve, it increases bypass wind velocity on its outer left side, inducing the wind in a particular fashion to enhance pressure reduction, and to create induction in low pressure wind ejection area 10.

Then we have horizontal circular flat floor section 12, which may be rotated as desired, to access wind direction, or to a position where

- 8 -

wind intake aperture area 7, and wind ejection area 10, are not accessed by extremely high winds.

Then we have fixed horizontal circular flat outer periphery floor ring 13, with beveled top outside edge around its circumference, and then fixed horizontal circular flat floor section 14, extending inward to center, from a radius point slightly outside of the turbine rotor, and continuing underneath turbine rotor 1, to the outer periphery of stairway / elevator tube 16, located at the center of the structure.

Then we have vertical cylindrical structural support wall 15, beginning close to the inside axle tube of the turbine rotor, and extending upward. Then we have vertical round cylindrical stairway and / or elevator tube 16, extending from below floor section 14, directly upward, concentric with structural support wall 15.

Structural support wall 15, serves a series of purposes, including concentric suspension and support for axle tube 6, of turbine rotor 1, at its lower and upper inside surface, and further supports office and control room 17, and fixed building roof section 18, as shown on figure two, and the said building roof section extends radially outward from said support wall 15, to a point beyond the outside top edge of turbine rotor 1.

Support wall 15, will be radially cross connected to the outside face of stairway / elevator tube 16, at floor level intervals, perhaps each ten feet, to add stability and strength to the overall turbine housing structure, and to allow added floor levels, if desired.

Stairway / elevator tube 16, will extend upward from a point well below the base of floor segment 14. A curve topped underground passageway (not shown) will extend laterally through the mounting mound or hilltop upon which the turbine engine unit is placed, to an outside point at ground level, to provide access for operating and maintenance personnel, and necessary pieces of equipment.

Stairway / elevator tube 16, will further extend upward to just below the rooftop of office and control room 17, as shown on figure two, for adequate placement of proper elevator and related drive system.

It should be further noted, that a spiral stairway is to be placed around the outside periphery of tube 16. From the surface of floor 14, a further stairway should extend downward to the underground passageway mentioned above, so personnel will have adequate emergency entry and exit provisions in case of elevator failure.

- 9 -

Figure two illustrates the completed placement of the wind turbine engine unit, with office and control room 17, at the top, and fixed round sloping roof segment or section, 18, radially attached to structural support wall 15, as shown in figure one, and then we have outer roof segment or section 19, shown on figure 2, which is base mounted to rotatable floor section 12, as shown in figure 1, by means of carefully spaced and interconnected vertical pillar tubes (not shown), enclosing the area between fixed roof section 18, as shown on figure 2, and outer wind channel containment wall 9, as shown on figure 1.

Also shown on figure 2, is extended support pole or tube 20, for navigational clearance light 21, usually essential for tall structures in open areas, in most states and countries.

Rather than break the continuity of the above description, and as shown on figure one, we had not mentioned that all power take-off systems, electrical generators, related mechanicals, and devices including basic electrical switch gear etc., could be placed at ground floor level on fixed inner floor section 14, with some essentials somewhat recessed downward below floor level, between cylindrical support wall 15, and center elevator tube 16. Also, there will be a series of arched and round openings in cylindrical support wall 15, for access to bearings, drive components concentric centering rollers etc., to allow easy access for essential lubrication, and maintenance.

Electrical power cables to deliver generated power to outside connections would be brought from the generator area, on or below fixed inner floor section 14, downward to exit by means of the access tunnel leading in from outside the turbine engine base mounting hill or mound.

- 10 -

CLAIMS

Based on the foregoing detailed description, together with further related comments and explanations, the objects of the subject invention, as set forth herein above have been addressed adequately, and are easily achievable. Also, while there is shown and described, a preferred embodiment of the invention, it is understood that the invention is not limited thereto, but may be otherwise variously embodied and applied within the scope of the following claims. Accordingly,

What is claimed is:

1. A wind turbine engine.
2. A wind turbine engine with its drive rotor situated within an internalized throughput containment and control chamber, assuring that a maximum amount of wind throughput must drive its turbine rotor blades.
3. A wind turbine engine which has its rotor blades situated within the outer half of the radius of its rotor, to gain greater mechanical advantage, and which also redirects all of the incoming wind throughput displaced by the blocked off inner 50% or more, of the radius of its wind driven rotor.
4. A wind turbine engine with internalized wind throughput and control chamber, where the radial distance of the outer containment wall of the said chamber, from radial center of the drive rotor of the said engine is progressively reduced, as it curves around the periphery of the said turbine rotor, increasing wind speed and adding a compression factor to the mass of wind throughput.

- 11 -

5. A wind turbine engine, with internalized wind throughput containment and control chamber, surrounding a large part of the circumference of its internalized turbine rotor, with the shape and nature of said chamber directing and forcing its wind throughput to constantly drive two thirds or more, of the blades on the said internalized turbine rotor.
6. A wind turbine engine configured, embodied or enclosed in such a fashion that it has an enlarged intake area, with some supercharging effect, plus increase in velocity of its wind throughput, along with compression of its said wind throughput, followed by a low pressure or vacuum exhaust area or port.
7. A wind turbine engine having the basic functions of a steam or gas turbine engine, with the exception of heat.
8. A wind turbine engine which may be placed or housed in a self containment enclosure, where such housing, exterior embodiment or enclosure may be shaped or designed in such a fashion that it may blend more easily into its environment or area of emplacement, to where it is less imposing to, and more attractive within the said surrounding environment or area of emplacement.
9. A wind turbine engine which can provide useable power output at wind speeds ranging from 10 to more than 100 kilometers (6.21 to more than 62.1 miles) per hour.

Figure 2

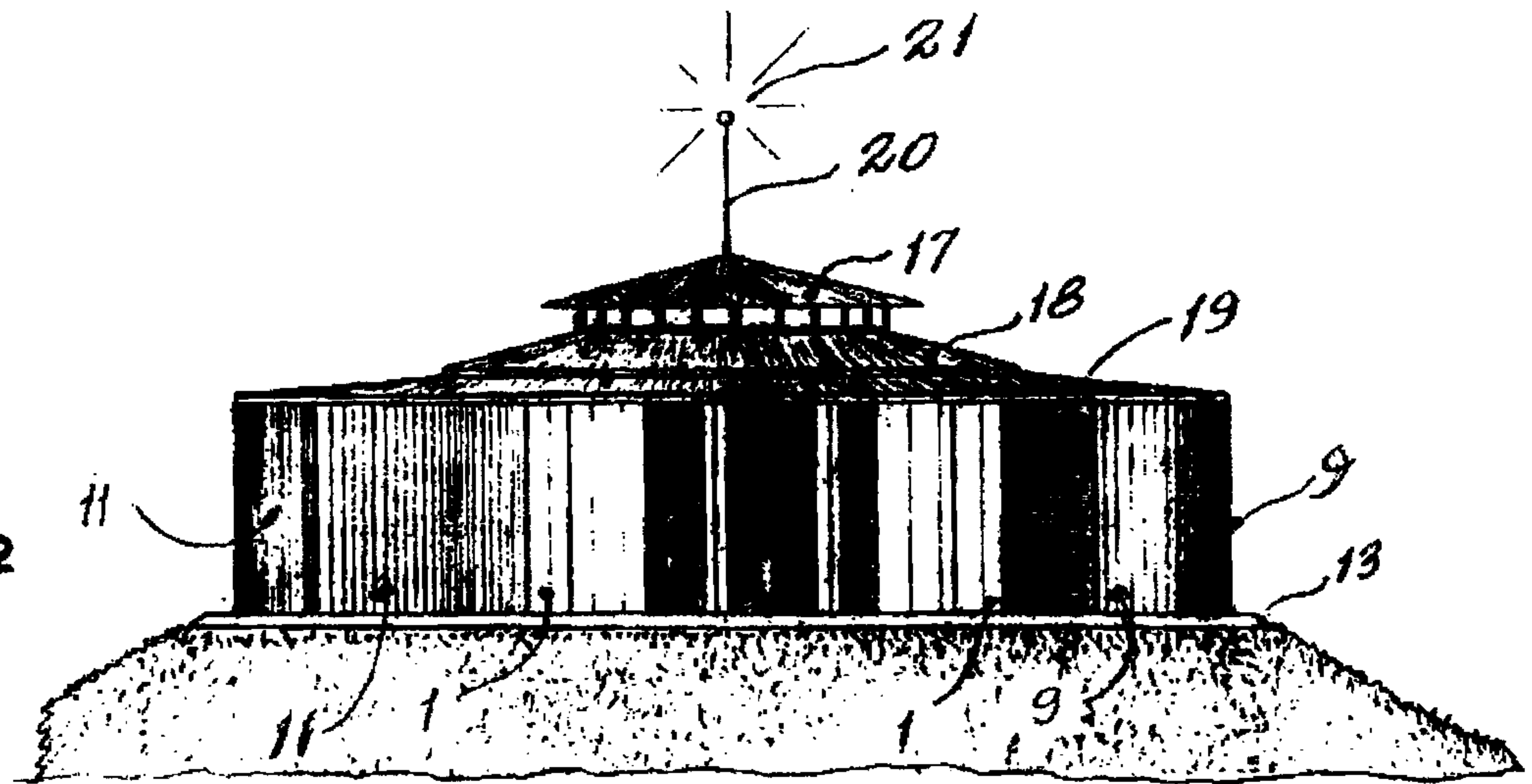

Figure 1

