



- (51) International Patent Classification:  
*F16B 35/04* (2006.01)      *B02C 17/22* (2006.01)
- (21) International Application Number:  
PCT/AU2017/051328
- (22) International Filing Date:  
04 December 2017 (04.12.2017)
- (25) Filing Language: English
- (26) Publication Language: English
- (30) Priority Data:  
2016905033      06 December 2016 (06.12.2016) AU
- (72) Inventor; and  
(71) Applicant: **OLDNALL, Craig** [AU/AU]; 9 Calder Way,  
Atwell, Western Australia 6164 (AU).
- (74) Agent: **HOLLIDAY, Neal Joseph**; PO Box 3099, Broad-  
way Nedlands, Western Australia 6009 (AU).
- (81) Designated States (*unless otherwise indicated, for every  
kind of national protection available*): AE, AG, AL, AM,  
AO, AT, AU, AZ, BA, BB, BG, BH, BN, BR, BW, BY, BZ,  
CA, CH, CL, CN, CO, CR, CU, CZ, DE, DJ, DK, DM, DO,

DZ, EC, EE, EG, ES, FI, GB, GD, GE, GH, GM, GT, HN,  
HR, HU, ID, IL, IN, IR, IS, JO, JP, KE, KG, KH, KN, KP,  
KR, KW, KZ, LA, LC, LK, LR, LS, LU, LY, MA, MD, ME,  
MG, MK, MN, MW, MX, MY, MZ, NA, NG, NI, NO, NZ,  
OM, PA, PE, PG, PH, PL, PT, QA, RO, RS, RU, RW, SA,  
SC, SD, SE, SG, SK, SL, SM, ST, SV, SY, TH, TJ, TM, TN,  
TR, TT, TZ, UA, UG, US, UZ, VC, VN, ZA, ZM, ZW.

(84) Designated States (*unless otherwise indicated, for every  
kind of regional protection available*): ARIPO (BW, GH,  
GM, KE, LR, LS, MW, MZ, NA, RW, SD, SL, ST, SZ, TZ,  
UG, ZM, ZW), Eurasian (AM, AZ, BY, KG, KZ, RU, TJ,  
TM), European (AL, AT, BE, BG, CH, CY, CZ, DE, DK,  
EE, ES, FI, FR, GB, GR, HR, HU, IE, IS, IT, LT, LU, LV,  
MC, MK, MT, NL, NO, PL, PT, RO, RS, SE, SI, SK, SM,  
TR), OAPI (BF, BJ, CF, CG, CI, CM, GA, GN, GQ, GW,  
KM, ML, MR, NE, SN, TD, TG).

Published:  
— with international search report (Art. 21(3))

(54) Title: LINER BOLT

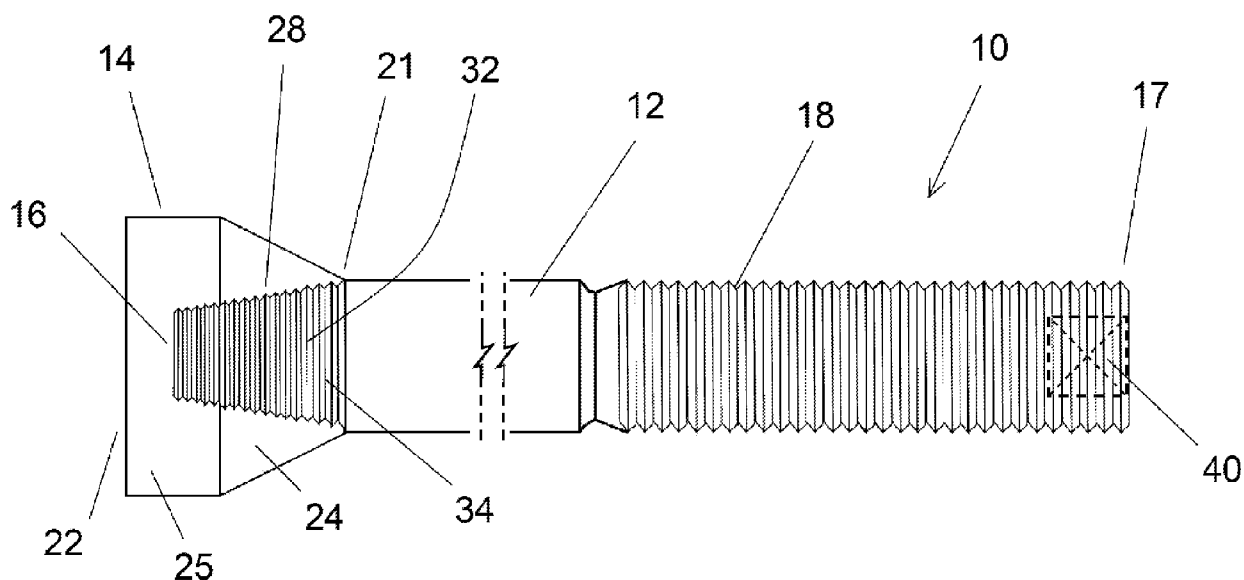

Fig 1

(57) Abstract: A liner bolt (10) comprising an elongate stud (12) and a head (14) engageable with a first end (16) of the stud (12). The head (14) including an inwardly tapered first end portion (24) adjacent a first end (21) thereof. A threaded portion (18) is provided adjacent a second end (17) of the stud for receiving a nut (20). The first end (21) of the head (14) includes an inwardly tapered opening (28) having an internal thread (30) and the first end (16) of the stud (12) includes an inwardly tapered end portion (32) having an external thread (34) such that the first end (16) of the stud (12) is engageable in the opening (28) in the head (14).



## “LINER BOLT”

### Field of the Invention

[001] The present invention relates to a liner bolt for securing a sacrificial wear surface, such as a liner within a grinding mill.

### Background to the Invention

[002] Grinding mills use liners which are secured to the inner surface of the mill by liner bolts. The liners provide both a protective surface, as well as surface features to assist with the grinding process.

[003] As the liners wear, it is necessary to periodically replace the liners. Liner bolts commonly comprise a shaft having a widened head which is received through a hole in the liner from the inside. The end of the liner bolt extends to the outside of the mill, where it is secured by a nut. When it is time to replace the liners, the nuts are removed and the bolts pushed inwardly into the inside of the mill. As these bolts can become jammed within the liner during operation of the mill, pushing the bolts inwardly will often require the use of an impact tool used to drive the bolt inwardly. Alternatively, the bolts may be driven by placing a rod against the outer end and driving with a hammer.

[004] The use of such impact tools can pose hazards to the operators and result in injury. Further, the time taken to drive in the bolts can be significant. As any time in which a mill is not operating results in increased costs, it is therefore important to ensure that the replacement of the liners can be achieved as efficiently as possible.

[005] A quick release liner bolt has been proposed in International patent publication number WO 2013116892. This liner bolt includes an inner bolt part received inside the liner and the shell of the mill which includes a threaded aperture in an outer end. A threaded outer bolt is received into this aperture from outside the mill. Removal of the liner bolt therefore involves rotation of

the outer bolt part to separate it from the inner bolt part. Such an arrangement creates a narrowed portion of the outer bolt which is located around the join between the shell and the liner. Such an arrangement can lead to failures in use.

[006] The present invention relates to a liner bolt having a construction aimed at allowing removal of the liner via rotation of the outer part of the bolt, rather than impact, in a form which can support sufficient load to reduce the likelihood of breakages during operation of the mill.

### **Summary of the Invention**

[007] According to one aspect of the present invention there is provided a liner bolt comprising:

an elongate stud;

a head having a first end engageable with a first end of the stud, the head including an inwardly tapered first end adjacent the first end thereof; and

a threaded portion provided adjacent a second end of the stud for receiving a nut;

wherein the first end of the head includes an inwardly tapered opening having an internal thread and the first end of the stud includes an inwardly tapered end portion having an external thread such that the first end of the stud is engageable in the opening in the head.

[008] Preferably the stud includes a tool engagement at the second end thereof for engagement by a rotating tool.

[009] Preferably the head includes a first end portion which tapers inwardly towards the first end of the head and a second end portion having a constant transverse cross section.

[010] In a preferred embodiment, the second end portion of the head is obround in transverse cross section.

[011] Preferably the first end portion of the head tapers inwardly in respect of height and not width.

[012] Preferably the first end portion is obround in transverse cross section throughout its length and circular in transverse cross section at the first end of the head.

[013] In a preferred embodiment, the tool engagement comprises a square drive socket provided in the second end of the stud.

### **Brief Description of the Drawings**

[014] The invention will now be described, by way of example, with reference to the following drawings, in which:

[015] Figure 1 is a side view of a liner bolt in accordance with the present invention;

[016] Figure 2 is a side view of the stud of the liner bolt of Figure 1;

[017] Figure 3a is an end view of the head of the liner bolt of Figure 1;

[018] Figure 3b is a side cross sectional view of the head of the liner bolt of Figure 1;

[019] Figure 4 is a side cross-sectional view of the liner bolt of Figure 1 installed in a mill;

[020] Figure 5 is a side cross-sectional view of the liner bolt of Figure 1 disengaged from the mill.

### **Detailed Description of Preferred Embodiments**

[021] Referring to the Figures, there is shown a liner bolt 10 comprising an elongate stud 12 and a head 14. The head 16 is engageable with a first end 16 of the stud 12 to form the liner bolt 10. The liner bolt 10 is to be used to secure a liner plate 11 to an outer shell 13 of a grinding mill.

[022] The stud 12 comprises an elongate member of circular cross-section. The stud 12 includes a threaded portion 18 adjacent a second end 17 thereof.

The threaded portion 18 is provided for receiving a nut 20 in use. The second end 17 of the stud 12 protrudes outwardly from the shell 13 of the mill such that engaging the nut 20 to the threaded portion 18 of the liner bolt 10 engages the liner bolt 10 with the liner plate 11 such that the liner plate 11 is secured to an inner surface of the shell 13.

[023] The stud 12 includes also a tool engagement 40 at the second end 17 thereof. The tool engagement 40 is provided to allow application of a rotational force to the stud 12 by a suitable tool. In the embodiment shown, the tool engagement 40 comprises a square drive socket provided in the second end of the stud 12.

[024] The head 14 includes a first end 21 and a second end 22. The head 14 includes a first end portion 24 adjacent the first end 21 which tapers inwardly towards the first end 21 of the head 14. The head 14 includes also a second end portion 25 extending from the first end portion 24 to the second end 22. The second end portion 25 has a constant transverse cross section.

[025] As can be seen in Figure 3a, the second end portion 25 of the head 14 is obround in transverse cross section. That is, the head 14 adjacent the second end portion 25 comprises linear parallel side walls 26 connected at opposed ends by arcuate end walls 27. The first end portion 24 of the head 14 tapers inwardly in respect of the height only (being the distance between the end walls 27) and not the width (being the distance between the side walls 26). The first end portion 24 is therefore also obround in transverse cross section with the first end portion 24 reducing in cross sectional area such that the first end portion 24 is circular in transverse cross section at the first end 21 of the head 14.

[026] The head 14 includes an opening 28 in the first end 21 thereof. The opening 28 is circular in transverse cross section and tapers inwardly such that an inner end thereof has a smaller diameter than an outer end thereof. The opening 28 includes an internal thread 30 on an inner surface thereof. The first end 16 of the stud 12 includes a tapered end portion 32 at the first end 16 thereof. The tapered end portion 32 also tapers inwardly

corresponding to the inward taper of the opening 28, such that the tapered end portion 32 may be received within the opening 28. The tapered end portion 32 of the stud 12 includes an external thread 34 thereon. The external thread 34 is complementary to the internal thread 30 such that the first end 16 of the stud 12 may be screwed into the opening 28 in the head 14.

[027] Figure 4 shows the liner bolt 10 engaged in a mill to secure the liner plate 11 to an inner surface of the shell 13. The liner bolt 10 is provided with the head 14 connected to the stud 12 and inserted into an aperture 15 in the liner plate 11 from the inside of the mill. The aperture 15 in the liner plate 11 aligns with a hole 17 in the shell 13 such that the second end 17 of the stud 12 passes outwardly to the exterior of the shell 13. A seal 36 and a washer 38 may be placed over the second end of the stud 12 and the nut 20 is then secured to the threaded portion 18 of the liner bolt 10. Tightening the nut 20 pulls the liner plate 11 towards the inner surface of the shell 13. A compressible lining 19 is provided between the liner plate 11 and the shell 13. The liner plate 11 is secured in position against the inner surface of the shell 13 by tightening the nut 20 on the liner bolt 10.

[028] When it is required to remove the liner bolt 10, a spanner or other suitable tool may be engaged with the nut 20. A tool is then engaged with the tool engagement 40 to rotate the stud 12 relative to the nut 20. Due to the shape of the head 14, the head 14 will not rotate within the liner plate 11 and the stud 12 therefore rotates relative to the head 14. This rotation unscrews the stud 12 from the head 14, thereby allowing the liner plate 11 and head 14 to disconnect and fall away from the inner surface of the shell 13.

[029] This arrangement therefore allows disconnection of the liner plate 11 by rotation only of the stud 12 from externally of the shell 13. The use of a tapered threaded engagement between the first ends of the stud 12 and the head 14 within the liner plate 11 removes potential weakened areas and therefore allows the connection to be sufficiently strong to support the required loads.

[030] It will be readily apparent to persons skilled in the relevant arts that various modifications and improvements may be made to the foregoing embodiments, in addition to those already described, without departing from the basic inventive concepts of the present invention.

## Claims

- 5 1. A liner bolt comprising:  
an elongate stud;  
a head having a first end engageable with a first end of the stud, the head  
including an inwardly tapered first end portion adjacent the first end thereof;  
and  
10 a threaded portion provided adjacent a second end of the stud for receiving a  
nut;  
wherein the first end of the head includes an inwardly tapered opening having  
an internal thread and the first end of the stud includes an inwardly tapered  
end portion having an external thread such that the first end of the stud is  
15 engageable in the opening in the head.
2. A liner bolt in accordance with claim 1, wherein the stud includes a tool  
engagement at the second end thereof for engagement by a rotating tool.
3. A liner bolt in accordance with claim 1 or 2, wherein the head includes  
20 a first end portion which tapers inwardly towards the first end of the head and  
a second end portion having a constant transverse cross section.
4. A liner bolt in accordance with claim 3, wherein the second end portion  
of the head is obround in transverse cross section.
5. A liner bolt in accordance with claim 5, wherein the first end portion of  
25 the head tapers inwardly in respect of height and not width.
6. A liner bolt in accordance with claim 6, wherein the first end portion is  
obround in transverse cross section throughout its length and circular in  
transverse cross section at the first end of the head.

7. A liner bolt in accordance with any one of claims 2 to 6, wherein the tool engagement comprises a square drive socket provided in the second end of the stud.

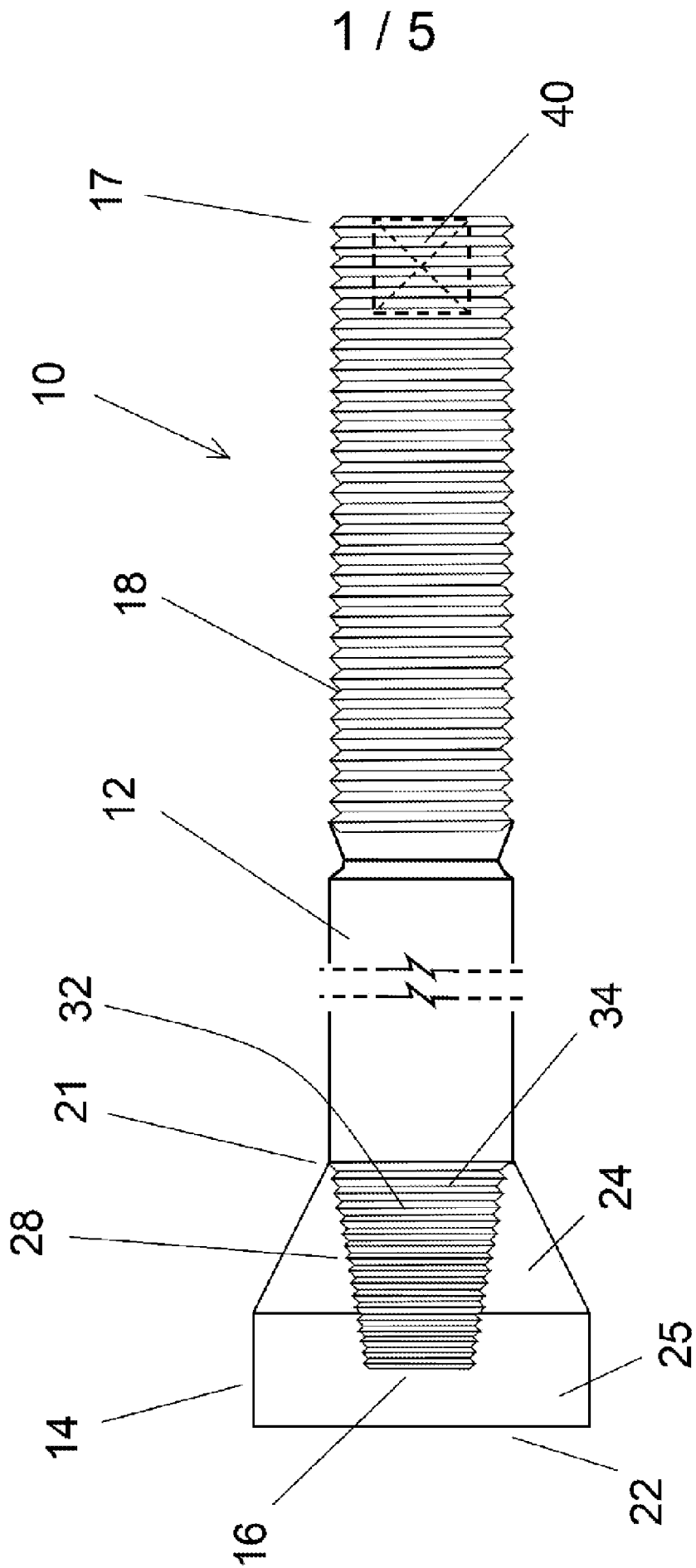

Fig 1

2 / 5

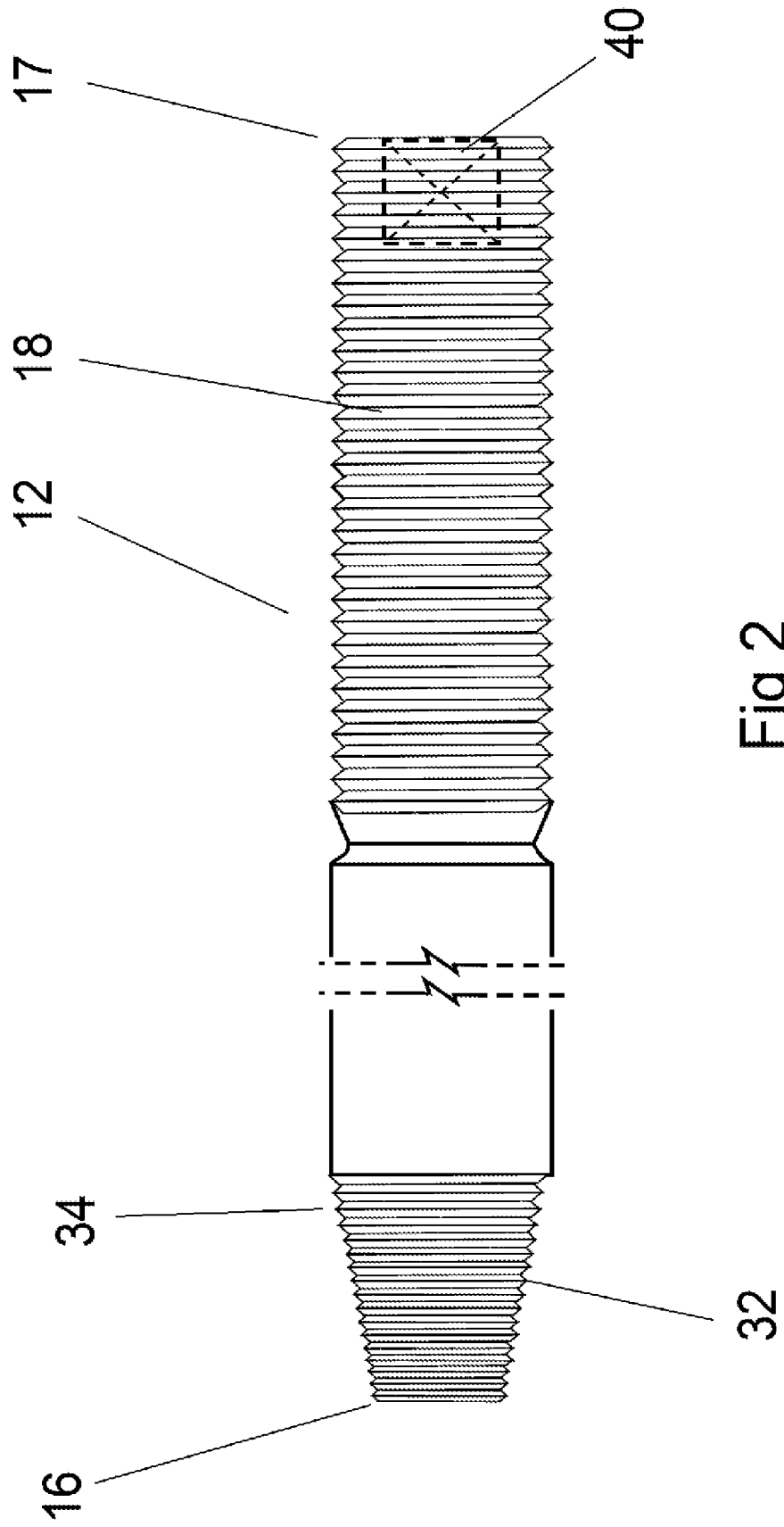

Fig 2

3 / 5

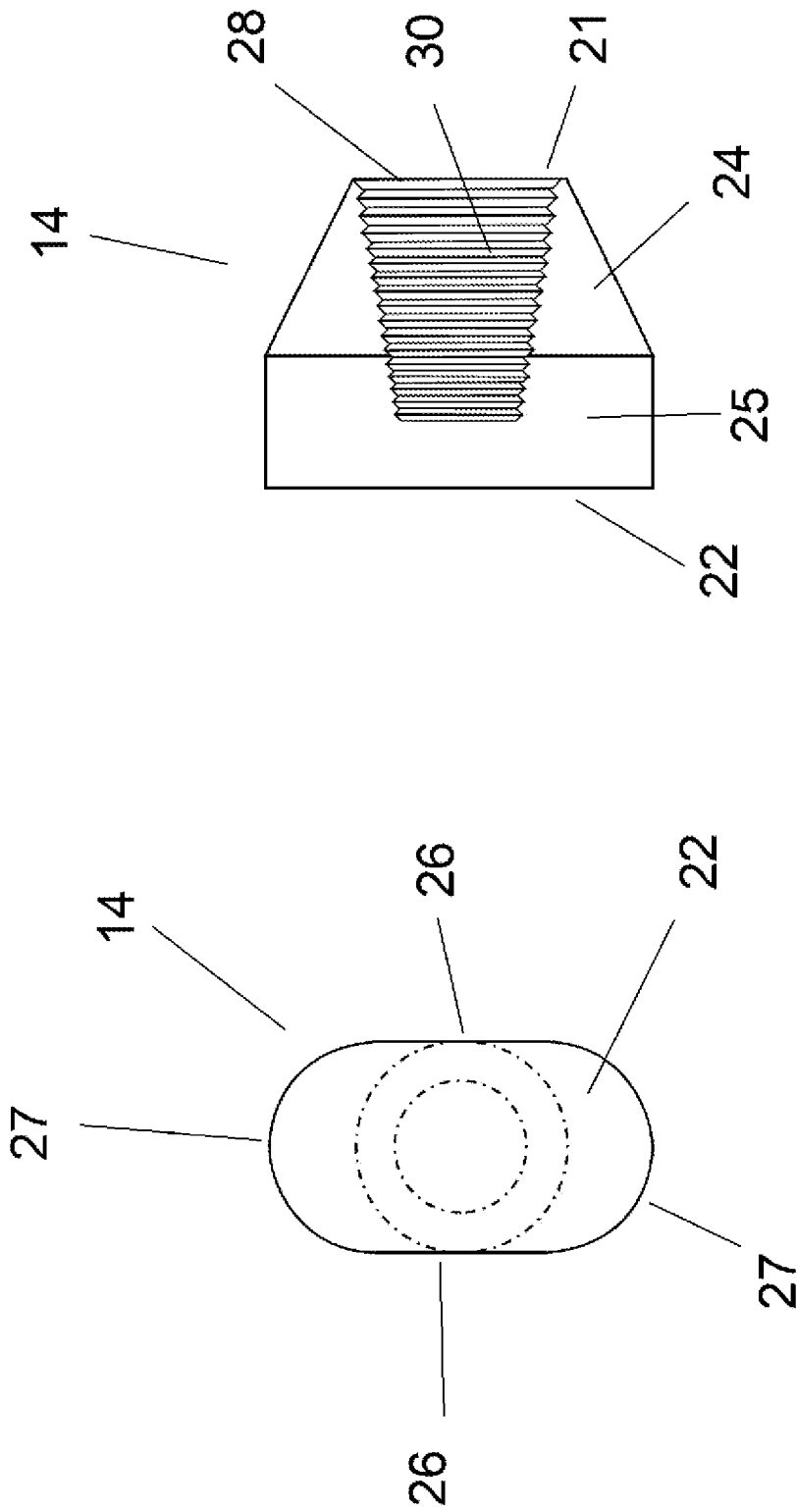

Fig 3b

Fig 3a

4 / 5

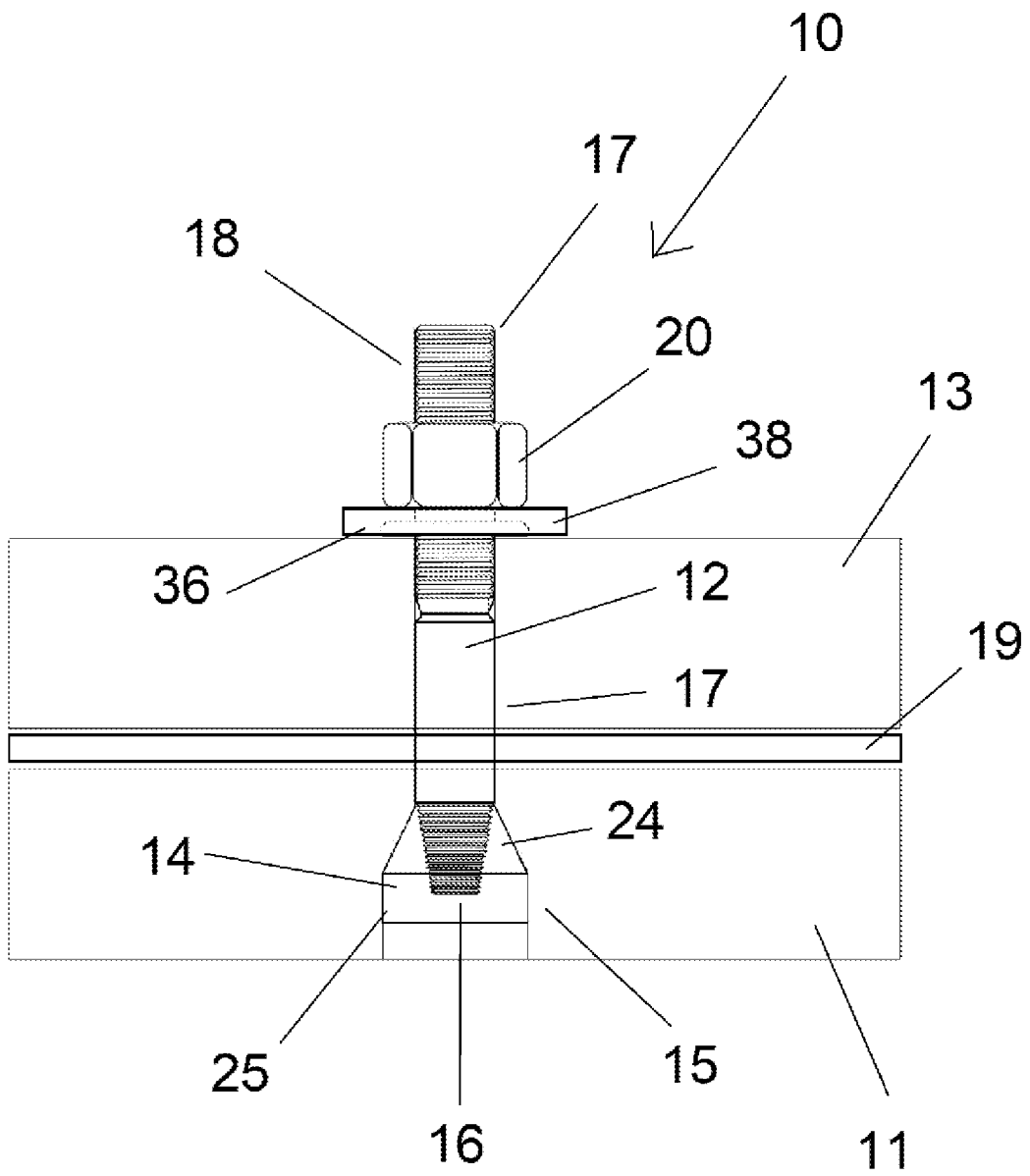

Fig 4

5 / 5

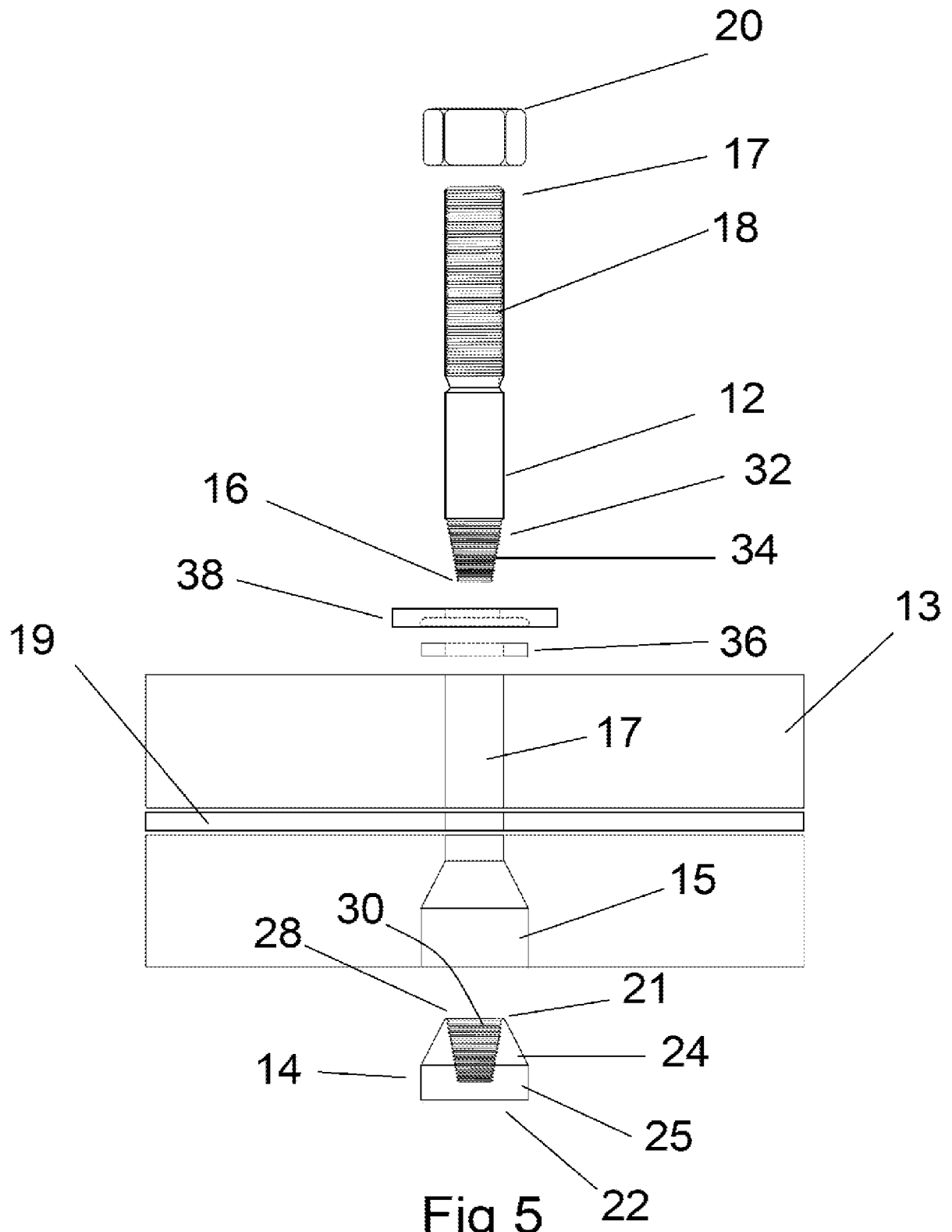

Fig 5

## A. CLASSIFICATION OF SUBJECT MATTER

**F16B 35/04 (2006.01) B02C 17/22 (2006.01)**

According to International Patent Classification (IPC) or to both national classification and IPC

## B. FIELDS SEARCHED

Minimum documentation searched (classification system followed by classification symbols)

Documentation searched other than minimum documentation to the extent that such documents are included in the fields searched

Electronic data base consulted during the international search (name of data base and, where practicable, search terms used)

Applicant(s)/Inventor(s) name searched in internal databases provided by IP Australia. Applicant(s)/Inventor(s) name searched in Espacenet, AusPat and Google. Search query: "Craig Oldnall" as the applicant AND/OR "Craig Oldnall" as the inventor(s); PATENW: EPODOC, WPIAP, TXPEA, TXPEB, TXPEC, TXPEE, TXPEF, TXPEH, TXPEI, TXPEP, TXPES, TXPEPEA, TXPUSE0A, TXPUSE1A, TXPUSEA, TXPUSEB, TXPW0EA; IPC, CPC: B02C17/22/LOW, F16B5/0275/LOW, F16B35/04/LOW and keywords: bolt, stud, nut, head, engage, thread, taper and like terms; Google Patent Search: Keywords: Liner, bolt, elongate, stud, head, opening, engageable, inwardly, tapered, internal, external, thread, nut, rotating, tool, engagement, square, drive, socket, obround, circular, transverse, cross-section and like terms.

## C. DOCUMENTS CONSIDERED TO BE RELEVANT

Category*	Citation of document, with indication, where appropriate, of the relevant passages	Relevant to claim No.
Documents are listed in the continuation of Box C		

 Further documents are listed in the continuation of Box C
  See patent family annex

* Special categories of cited documents:		
"A" document defining the general state of the art which is not considered to be of particular relevance	"T" later document published after the international filing date or priority date and not in conflict with the application but cited to understand the principle or theory underlying the invention	
"E" earlier application or patent but published on or after the international filing date	"X" document of particular relevance; the claimed invention cannot be considered novel or cannot be considered to involve an inventive step when the document is taken alone	
"L" document which may throw doubts on priority claim(s) or which is cited to establish the publication date of another citation or other special reason (as specified)	"Y" document of particular relevance; the claimed invention cannot be considered to involve an inventive step when the document is combined with one or more other such documents, such combination being obvious to a person skilled in the art	
"O" document referring to an oral disclosure, use, exhibition or other means	"&" document member of the same patent family	
"P" document published prior to the international filing date but later than the priority date claimed		

Date of the actual completion of the international search 19 January 2018	Date of mailing of the international search report 19 January 2018
<b>Name and mailing address of the ISA/AU</b>  AUSTRALIAN PATENT OFFICE PO BOX 200, WODEN ACT 2606, AUSTRALIA Email address: pct@ipaaustralia.gov.au	<b>Authorised officer</b>  Savio Albuquerque AUSTRALIAN PATENT OFFICE (ISO 9001 Quality Certified Service) Telephone No. +61262832913

## INTERNATIONAL SEARCH REPORT

International application No.

C (Continuation).

DOCUMENTS CONSIDERED TO BE RELEVANT

**PCT/AU2017/051328**

Category*	Citation of document, with indication, where appropriate, of the relevant passages	Relevant to claim No.
Y	US 6082646 A (CLARKE et al.) 04 July 2000 Figures 9-12 and column 6, line 8 - column 7, line 2	1-7
Y	US 3742809 A (ZIFFERER) 03 July 1973 Figures 1-3, 5, 6, 9-11 and column 3, line 60 - column 6, line 21	1-7
Y	US 3921364 A (BRILES) 25 November 1975 Abstract, figures 5, 6 and column 4, line 19 - column 5, line 2	1-7
A	WO 2013/116892 A1 (DONHAD PTY LTD) 15 August 2013 Abstract, figures 3, 4 and page 3, line 33 - page 5, line 12	1-7

**INTERNATIONAL SEARCH REPORT**

Information on patent family members

International application No.

**PCT/AU2017/051328**

This Annex lists known patent family members relating to the patent documents cited in the above-mentioned international search report. The Australian Patent Office is in no way liable for these particulars which are merely given for the purpose of information.

<b>Patent Document/s Cited in Search Report</b>		<b>Patent Family Member/s</b>	
<b>Publication Number</b>	<b>Publication Date</b>	<b>Publication Number</b>	<b>Publication Date</b>
US 6082646 A	04 July 2000	US 6082646 A	04 Jul 2000
		AU 5775000 A	30 Jan 2001
		BR 0012236 A	26 Mar 2002
		CA 2277575 A1	07 Jan 2001
		WO 0103839 A1	18 Jan 2001
US 3742809 A	03 July 1973	US 3742809 A	03 Jul 1973
		BE 784500 A	07 Dec 1972
		CA 953137 A	20 Aug 1974
		DE 2206088 A1	02 Aug 1973
		GB 1389072 A	03 Apr 1975
		JP S509941 B1	17 Apr 1975
		LU 65475 A1	22 Jan 1973
		NL 7208705 A	06 Feb 1973
US 3921364 A	25 November 1975	US 3921364 A	25 Nov 1975
		DE 2439377 A1	27 Feb 1975
		FR 2241015 A1	14 Mar 1975
		GB 1449307 A	15 Sep 1976
		JP S5049541 A	02 May 1975
		US 3849964 A	26 Nov 1974
WO 2013/116892 A1	15 August 2013	WO 2013116892 A1	15 Aug 2013
		AU 2013218783 A1	28 Aug 2014
		CA 2863804 A1	15 Aug 2013
		US 2015028142 A1	29 Jan 2015

**End of Annex**

Due to data integration issues this family listing may not include 10 digit Australian applications filed since May 2001.

Form PCT/ISA/210 (Family Annex)(July 2009)