

(19) World Intellectual Property Organization  
International Bureau



(43) International Publication Date  
20 May 2010 (20.05.2010)

(10) International Publication Number  
**WO 2010/054479 A1**

(51) International Patent Classification:

*B01L 9/06* (2006.01) *G01N 35/00* (2006.01)  
*B65G 49/00* (2006.01) *G01N 35/04* (2006.01)

(21) International Application Number:

PCT/CA2009/001642

(22) International Filing Date:

16 November 2009 (16.11.2009)

(25) Filing Language:

English

(26) Publication Language:

English

(30) Priority Data:

61/114,998 14 November 2008 (14.11.2008) US

(71) Applicant (for all designated States except US): **DYNA-CON INC.** [CA/CA]; 3565 Nashua Drive, Mississauga, Ontario L4V 1R1 (CA).

(72) Inventors; and

(75) Inventors/Applicants (for US only): **MIKHAILOV, Serguei** [CA/CA]; Mississauga, Ontario (CA). **KAKUSIK, Robert** [CA/CA]; Mississauga, Ontario

(CA). **FAYEK, Reda** [CA/CA]; Mississauga, Ontario (CA). **STOPKA, Marek** [CA/CA]; Mississauga, Ontario (CA). **MAGUIRE, Kieran** [CA/CA]; Adjala Tosorontio, Ontario (CA).

(74) Agent: **GRAHAM, Robert, J.**; Heenan Blaikie LLP, 333 Bay Street, Suite 2900, Bay Adelaide Centre, Toronto, Ontario M5H 2T4 (CA).

(81) Designated States (unless otherwise indicated, for every kind of national protection available): AE, AG, AL, AM, AO, AT, AU, AZ, BA, BB, BG, BH, BR, BW, BY, BZ, CA, CH, CL, CN, CO, CR, CU, CZ, DE, DK, DM, DO, DZ, EC, EE, EG, ES, FI, GB, GD, GE, GH, GM, GT, HN, HR, HU, ID, IL, IN, IS, JP, KE, KG, KM, KN, KP, KR, KZ, LA, LC, LK, LR, LS, LT, LU, LY, MA, MD, ME, MG, MK, MN, MW, MX, MY, MZ, NA, NG, NI, NO, NZ, OM, PE, PG, PH, PL, PT, RO, RS, RU, SC, SD, SE, SG, SK, SL, SM, ST, SV, SY, TJ, TM, TN, TR, TT, TZ, UA, UG, US, UZ, VC, VN, ZA, ZM, ZW.

(84) Designated States (unless otherwise indicated, for every kind of regional protection available): ARIPO (BW, GH, GM, KE, LS, MW, MZ, NA, SD, SL, SZ, TZ, UG, ZM,

[Continued on next page]

(54) Title: UNIVERSAL CONTAINER CARRIER

(57) Abstract: A universal container carrier includes a base plate, and a pair of support frames coupled to the base plate. At least one of the support frames is configured to move relative to the other support frame. Each support frame comprises at least one container support configured to engage a portion of the side wall of a container disposed between the support frames. The container carrier also includes a resilient biasing mechanism that is coupled to the base plate and the at least one support frame, and is configured to urge the at least one support frame towards the other support frame.

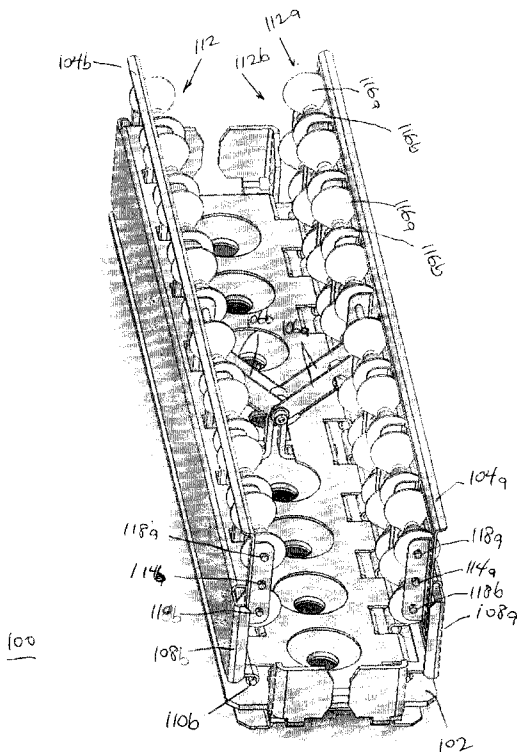

FIG. 1

WO 2010/054479 A1



ZW), Eurasian (AM, AZ, BY, KG, KZ, MD, RU, TJ, TM), European (AT, BE, BG, CH, CY, CZ, DE, DK, EE, ES, FI, FR, GB, GR, HR, HU, IE, IS, IT, LT, LU, LV, MC, MK, MT, NL, NO, PL, PT, RO, SE, SI, SK, SM, TR), OAPI (BF, BJ, CF, CG, CI, CM, GA, GN, GQ, GW, ML, MR, NE, SN, TD, TG).

**Published:**

- *with international search report (Art. 21(3))*
- *before the expiration of the time limit for amending the claims and to be republished in the event of receipt of amendments (Rule 48.2(h))*

**Declarations under Rule 4.17:**

- *of inventorship (Rule 4.17(iv))*

## UNIVERSAL CONTAINER CARRIER

## RELATED APPLICATIONS

[0001] This patent application claims the benefit of the filing date of United States Patent Application serial number 61/114,998, entitled "Universal Container Carrier", filed November 14, 2008, the contents of which are incorporated herein by reference.

## FIELD

[0002] This patent application relates to an apparatus for holding a plurality of containers. In particular, this patent application relates to a container carrier for transporting a plurality of specimen containers.

## BACKGROUND

[0003] Specimen containers are used in laboratory environments for storing and transporting specimens to be tested. Specimen containers come in a variety of sizes depending on the characteristics or the amount of a specimen needing to be stored or transported. Industry standards may also dictate the type of container to be used for transporting a particular specimen.

[0004] Testing specimens one at a time may be a time consuming and labor intensive process. Therefore, specimen testing may be automated. However, multiple sizes of specimen containers may be delivered to a laboratory for specimen testing, thereby frustrating the automated testing process.

[0005] Emmitt (US 4,124,122) describes a rack or holder for test tubes comprising a base and at least one test tube support plate member spaced apart from the base substantially parallel thereto. Both the base and the support plate member are provided with corresponding vertically aligned apertures. A toroidal resilient member having internal diameter slightly less than the outside diameter of the test tubes is disposed in each aperture. A test tube is retained in the holder via the apertures of the base and plate, and held in place by friction from the resilient member.

[0006] Mawhirt (US 4,861,553) describes an automatic sampling system including a test apparatus for testing fluid withdrawn from a closed test tube. Stoppered test tubes

are continuously and automatically delivered to the test apparatus by a conveyor system that includes a continuous linkage of test tube holders.

[0007] Morrison (US 5,632,338) describes a test tube rack assembly including a test tube rack pivotally connected to a base having an end support structure for allowing pivoting motion of the test tube rack.

[0008] Yamakawa (US 6,255,614) describes a specimen-container transfer apparatus comprising a conveyor unit for transporting specimen-container racks, a specimen-container transfer mechanism for taking specimen containers out of a specimen-container rack and putting them in a specimen-container housing rack, and a control unit for controlling the order in which the specimen containers are put into the specimen-container housing racks.

## SUMMARY

[0009] As described in this patent application, the container carrier comprises a base plate, and a pair of support frames coupled to the base plate. At least one of the support frames is configured to move relative to the other support frame. Each support frame comprises at least one container support configured to engage a portion of the side wall of a container disposed between the support frames. The container carrier also includes a resilient biasing mechanism that is coupled to the base plate and the at least one support frame, and is configured to urge the at least one support frame towards the other support frame.

[0010] The support frames may each have an elongate axis that extends between the carrier end members. At least one of the container supports may comprise a rotatable support that is configured for rotation about the elongate axis. The rotatable support may comprise an elongate shaft, and a pair of conically-shaped roller members that are rotatable disposed on the elongate shaft. Each conical roller member may have a base portion and an apex portion, with the apex portions of the conical roller members being disposed proximate each other.

[0011] The support frames may be coupled to the base plate through a pivoting linkage that is coupled to a centre portion of the base plate. The resilient biasing mechanism may comprise a pair of wings that is hingedly coupled to opposite sides of the

base plate, and biasing springs that are coupled to the base plate and the wings, configured such that the wings and the biasing springs urge the support frames towards each other.

[0012] The support frames may each have an elongate axis that extends between the support frame ends, and may be configured to move relative to the each other along an axis that is perpendicular to the elongate axis. The wings may be configured to move the support frames relative to the each other along an axis perpendicular to the elongate axis.

[0013] The support frames may each have a pair of opposite ends and an elongate axis that extends between the opposite ends. At least one of the container supports may comprise a pair of rotatable supports that are configured for rotation about a respective axis that is parallel to the elongate support frame axis. One of the rotatable supports may be disposed above the other rotatable support.

#### BRIEF DESCRIPTION OF THE DRAWINGS

[0014] The aforementioned features will now be described, by way of example, with reference to the accompanying drawings, in which:

Fig. 1 is an upper perspective view of the universal container carrier;

Fig. 2 is a bottom perspective view of the universal container carrier;

Fig. 3 is a top plan view of the universal container carrier;

Fig. 4 is a side elevation of the universal container carrier;

Fig. 5 is a side perspective view of the universal container carrier, with the container supports removed for clarity; and

Fig. 6 is an end elevation of the universal container carrier, with the container supports removed for clarity.

#### DETAILED DESCRIPTION

[0015] The drawings depict a universal container carrier, denoted generally as 100, that comprises a base plate 102, and a pair of support frames 104 (denoted individually as 104a, 104b) that are coupled to the base plate 102. At least one of the support frames 104 is configured to move relative to the other support frame 104. The universal container carrier 100 also includes a resilient biasing mechanism that is coupled to the base plate

102 and the moveable support frame 104, and is configured to urge the movable support frame 104 towards the other support frame 104.

[0016] At least one of the support frames 104 may be coupled to the base plate 102 through one or more pivoting linkages. Preferably, both of the support frames 104 are movable relative to each other, and are coupled to the base plate 102 through pivoting linkages 106 (denoted individually as 106a, 106b) that are pivotally coupled to a centre portion of the base plate 102. As shown, the pivoting linkages 106 may be coupled to the respective support frames 104 via a respective elongate shaft 114 that extends along the length of each support frame 104. As will become apparent, with this configuration the vertical orientation of the support frames 104 self-adjusts to the shape of the containers that are disposed between the support frames 104. Alternately, the support frames 104 may be coupled to the base plate 102 through a pivoting linkage (not shown) that is pivotally coupled to the opposite ends of the base plate 102 and the support frames 104.

[0017] One of the support frames 104 may comprise a container support 112 that is configured to engage a portion of the side wall of a container that is disposed between the support frames 104. Preferably, the container support 112 presents the container with V-shaped support surface to retain the container within the container support 112. Further, typically the container has a substantially cylindrical shape. However, the container is not limited to any particular configuration, but can include, for example, prescription bottles, biological specimen containers and test tubes.

[0018] Preferably, each support frame 104 comprises one of the container supports 112, disposed such the container support 112 of the support frame 104a is disposed opposite the container support 112 of the support frame 104b. With this configuration, the container supports 112 are disposed to securely capture a container that is disposed between the support frames 104.

[0019] More preferably, as shown, each support frame 104 comprises a plurality of the container supports 112, configured such that each container support 112 of the support frame 104a is disposed opposite a respective container support 112 of the support frame 104b. With this configuration, the universal container carrier 100 is able to securely carry a plurality of the containers via the support frames 104 and the base plate

106. Further, as shown, the base plate 102 may include a plurality of apertures or recesses for engagement with a bottom portion of the containers.

[0020] To accommodate the plurality of container supports 112 within the support frame 104, preferably each support frame 104 has an elongated rectangular shape and an elongate axis. The elongate axis of the support frame 104a is oriented substantially parallel to the elongate axis of the support frame 104b. Further, the support frames 104 are configured to move relative to the each other along an axis that is perpendicular to the elongate axis.

[0021] To allow the containers to be easily inserted and removed from the universal container carrier 100, each container support 112 may be configured for rotation about an axis that is substantially parallel to the elongate axis of the respective support frame 104. Moreover, to increase the stability provided by the container support 112, each container support 112 may comprise a pair of rotatable supports 112a, 112b that are configured for rotation about a respective axis that is parallel to the elongate axis of the respective support frame 104. As shown, the rotatable support 112a is disposed above the rotatable support 112b.

[0022] In order to present the container with a V-shaped support surface, preferably the support frame 104 carries a pair of elongate shafts 118a, 118b that are disposed one above the other, and each rotatable support 112a, 112b comprises a pair of conically-shaped roller members (denoted individually as 116a, 116b) that are rotatably mounted on the respective elongate shaft 118. As shown, the elongate shaft 114 is disposed between the elongate shafts 118a 118b, and each elongate shaft 118 extends substantially parallel to the elongate axis of the respective support frame 104.

[0023] Each conical roller member 116 has a base portion and an apex portion, and the container support 112 is oriented such that the central axis of the conical roller members 116 coincides with the axis of the respective elongate shaft 118. The apex portion of the conical roller member 116a is disposed proximate the apex portion of the conical member 116b. Further the apex portions of the rotatable supports 112a, 112b of the support frame 104a are disposed opposite the apex portions of the respective rotatable supports 112a, 112b of the support frame 104b. Preferably, each conical roller member

116 is fabricated from a resilient material to accommodate minor differences in the diameters of the containers that are carried by the universal container carrier 100.

[0024] The resilient biasing mechanism may comprise a pair of pivoting wings 108 (denoted individually as 108a, 108b), and biasing springs (not shown). The pivoting wings 108 are hingedly coupled, at their respective bottom edges, to opposite sides of the base plate 102 via respective hinges 110a, 110b that extend in a direction that is substantially parallel to the elongate axis of the base plate 102. Preferably, the pivoting wings 108 are also pivotally coupled, at their respective upper (free) edges, to the support frames 104 along the elongate shaft 114 of the support frames 104. This configuration allows each support frame 104 to pivot about an axis that is substantially parallel to the elongate axis of the elongate shaft 114, and maintains each support frame 104 in a substantially vertical position as the support frames 104 move inwards towards the centre of the universal container carrier 100 and outwards from the centre of the universal container carrier 100.

[0025] The biasing springs are coupled to the base plate 102 and the pivoting wings 108 along the length of the hinges 110, and are configured to cause each pivoting wing 108 to rotate about its respective hinge 110, in an inwardly direction towards the centre of the universal container carrier 100. The inwards rotational movement of the wings 108 causes the upper (free) edges of the pivoting wings 108 to move laterally inwards towards each other. As a result, the support frames 104 are urged by the wings 108 to move towards each other along an axis that is perpendicular to the elongate axis of the base plate 102, thereby allowing a container to be captured between opposing container supports 112.

[0026] When the universal container carrier 100 is empty, the biasing springs urge the support frames 104 to move towards each other until the container supports 112 of the support frame 104a contact the container supports 112 of the support frame 104b. As a result, the empty space between pairs of opposing container supports 112 is at or near minimum. Containers are inserted into the universal container carrier 100 by directing each container downwards into the space between a pair of opposing container supports 112.

[0027] When the first container is inserted, the support frames 104 move laterally away from each other, via the pivoting linkages 106, as the container engages the roller members 116, until the container is fully inserted into the universal container carrier 100. Further lateral movement of the support frames 104 is prevented by the biasing springs and the pivoting wings 108. Also, the biasing springs and the pivoting wings 108 cause the support frames 104 to firmly press the container supports 112 against the sides of the container, thereby retaining the container within the universal container carrier 100. Additional containers, having substantially the same diameter as the first container, may also be inserted into the universal container carrier 100.

[0028] The containers are removed from the universal container carrier 100 by pulling each container upwards from the respective container supports 112. When the last container is removed, the support frames 104 move laterally towards each other, via the pivoting linkages 106, under the biasing action of the biasing springs and the pivoting wings 108, until the container supports 112 of the support frame 104a contact the container supports 112 of the support frame 104b.

[0029] Since the universal container carrier 100 automatically self-adjusts to the size of the container, a laboratory need not purchase container carriers that are specifically sized to the size of the containers.

## CLAIMS:

1. A universal container carrier comprising:
  - a base plate;
  - a pair of support frames coupled to the base plate, at least one of the support frames being configured to move relative to the other support frame, each said support frame comprising at least one container support configured to engage a portion of the side wall of a container disposed between the support frames; and
  - resilient biasing mechanism coupled to the base plate and the at least one support frame and configured to urge the at least one support frame towards the other support frame.
2. The container carrier according to Claim 1, wherein the support frames each have an elongate axis, at least one of the container supports comprises a rotatable support, the rotatable support being configured for rotation about the elongate axis.
3. The container carrier according to Claim 2, wherein the rotatable support comprises an elongate shaft, and a pair of conically-shaped roller members rotatable disposed on the elongate shaft.
4. The container carrier according to Claim 3, wherein each conical roller member has a base portion and an apex portion, and the apex portions of the conical roller members are disposed proximate each other.
5. The container carrier according to any one of Claims 1 to 4, wherein the support frames are coupled to the base plate through a pivoting linkage that is pivotally coupled to a centre portion of the base plate.
6. The container carrier according to any one of Claims 1 to 5, wherein the resilient biasing mechanism comprises a pair of wings hingedly coupled to opposite sides of the base plate, and biasing springs coupled to the base plate and the wings, the wings and the biasing springs urging the support frames towards each other.
7. The container carrier according to Claim 6, wherein the support frames each have a pair of opposite ends and an elongate axis extending between the opposite ends, and the wings are configured to move the support frames relative to the each other along an axis perpendicular to the elongate axis.

8. The container carrier according to Claim 1, wherein the support frames each have a pair of opposite ends and an elongate axis extending between the opposite ends, at least one of the container supports comprises a pair of rotatable supports, each rotatable support being configured for rotation about a respective axis parallel to the elongate axis.
9. The container carrier according to Claim 8, wherein one of the rotatable supports is disposed above the other rotatable support.

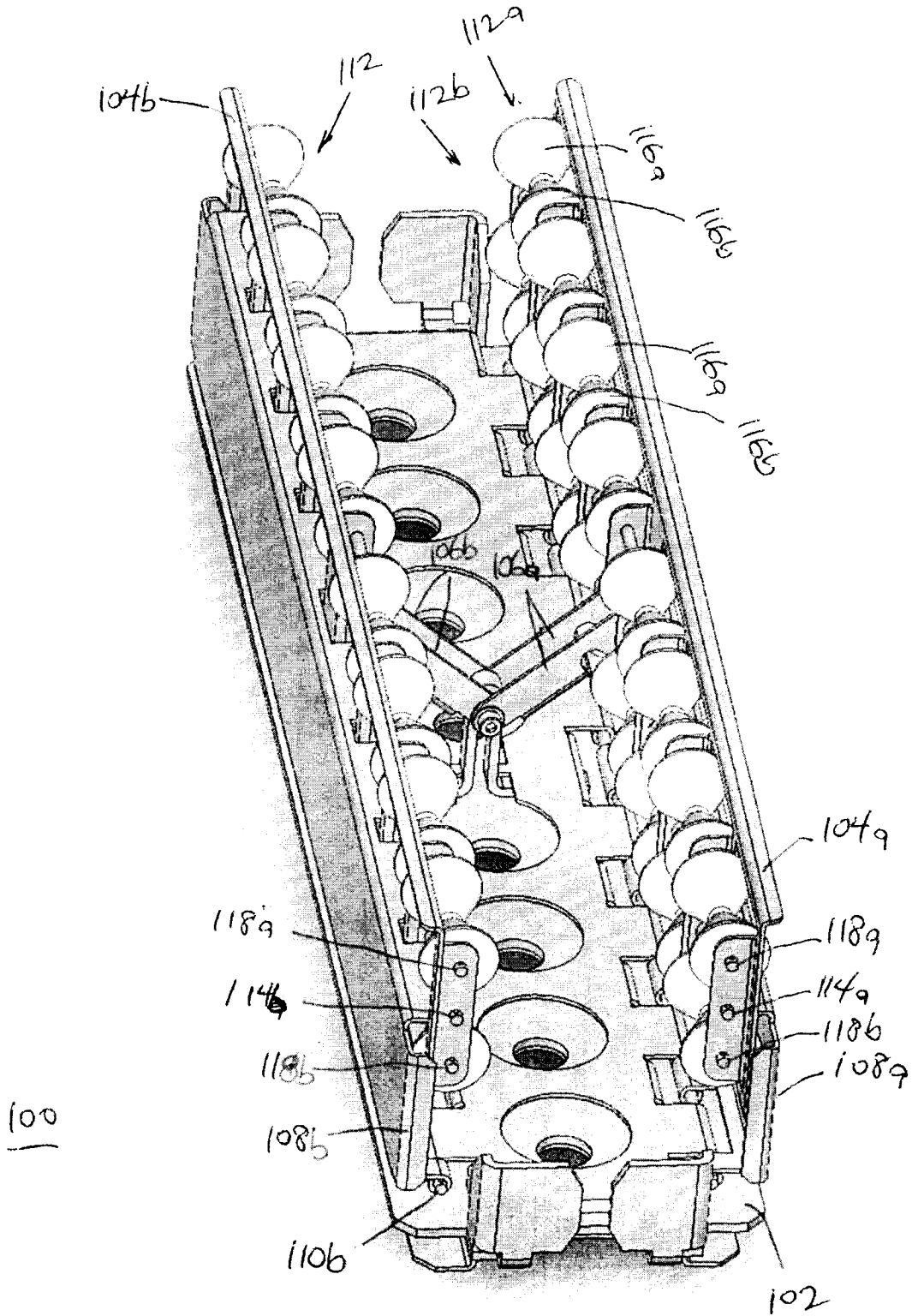

FIG. 1

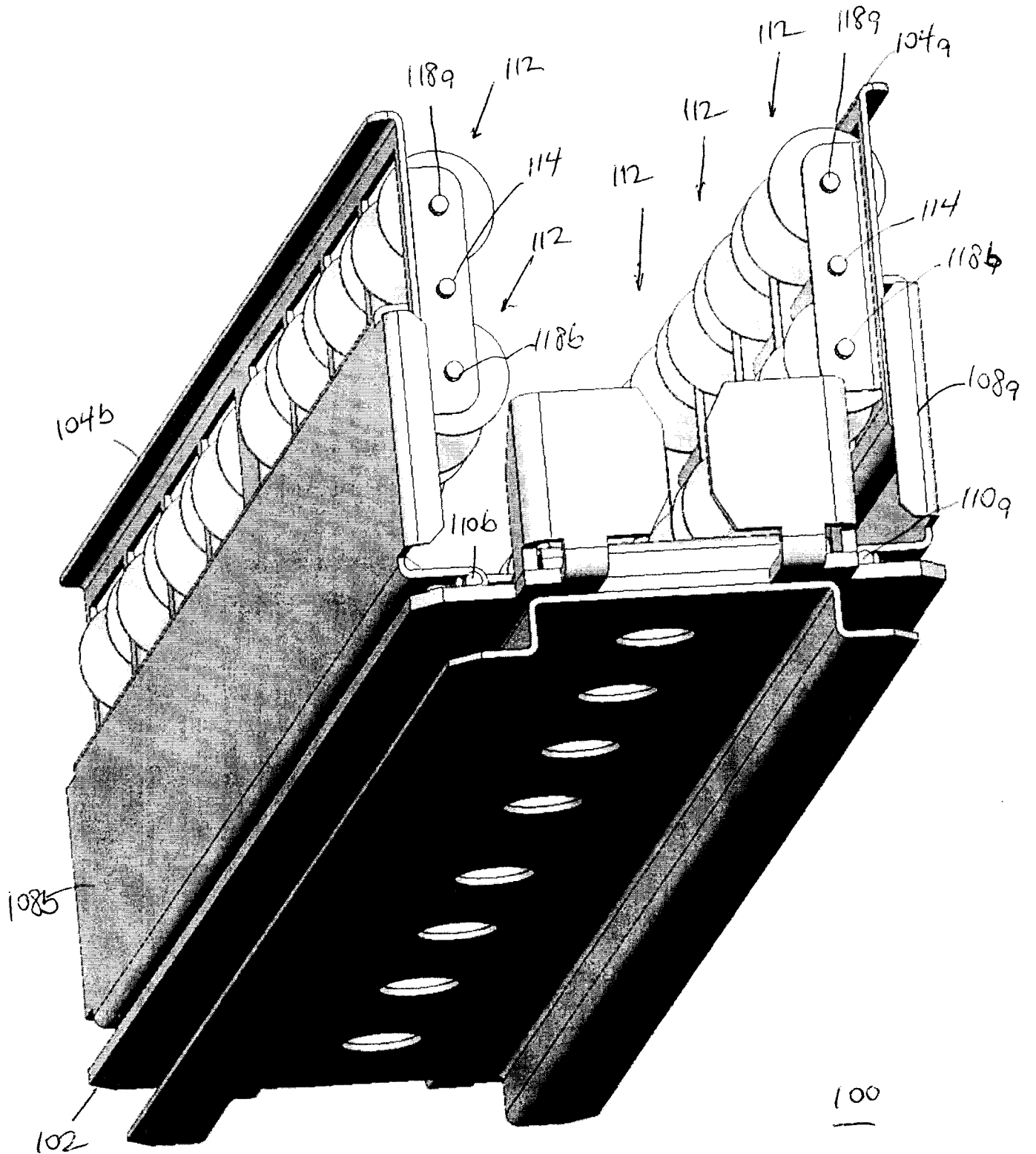

FIG. 2

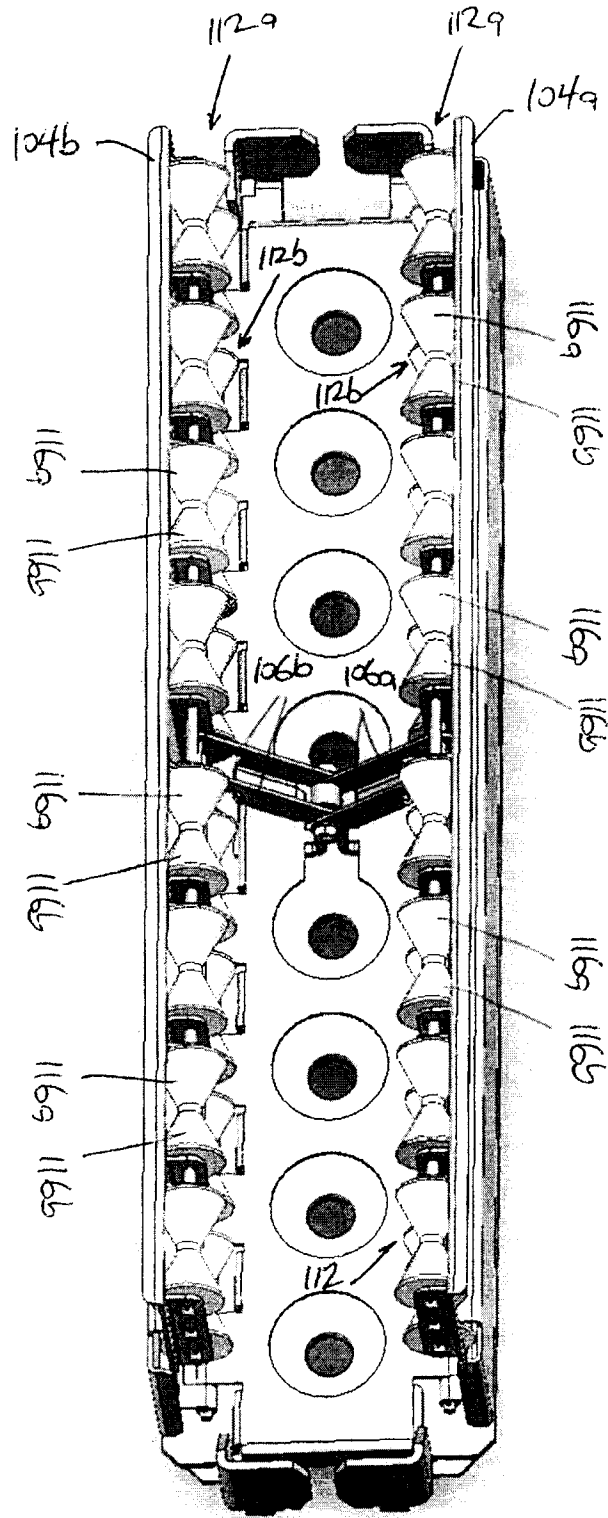
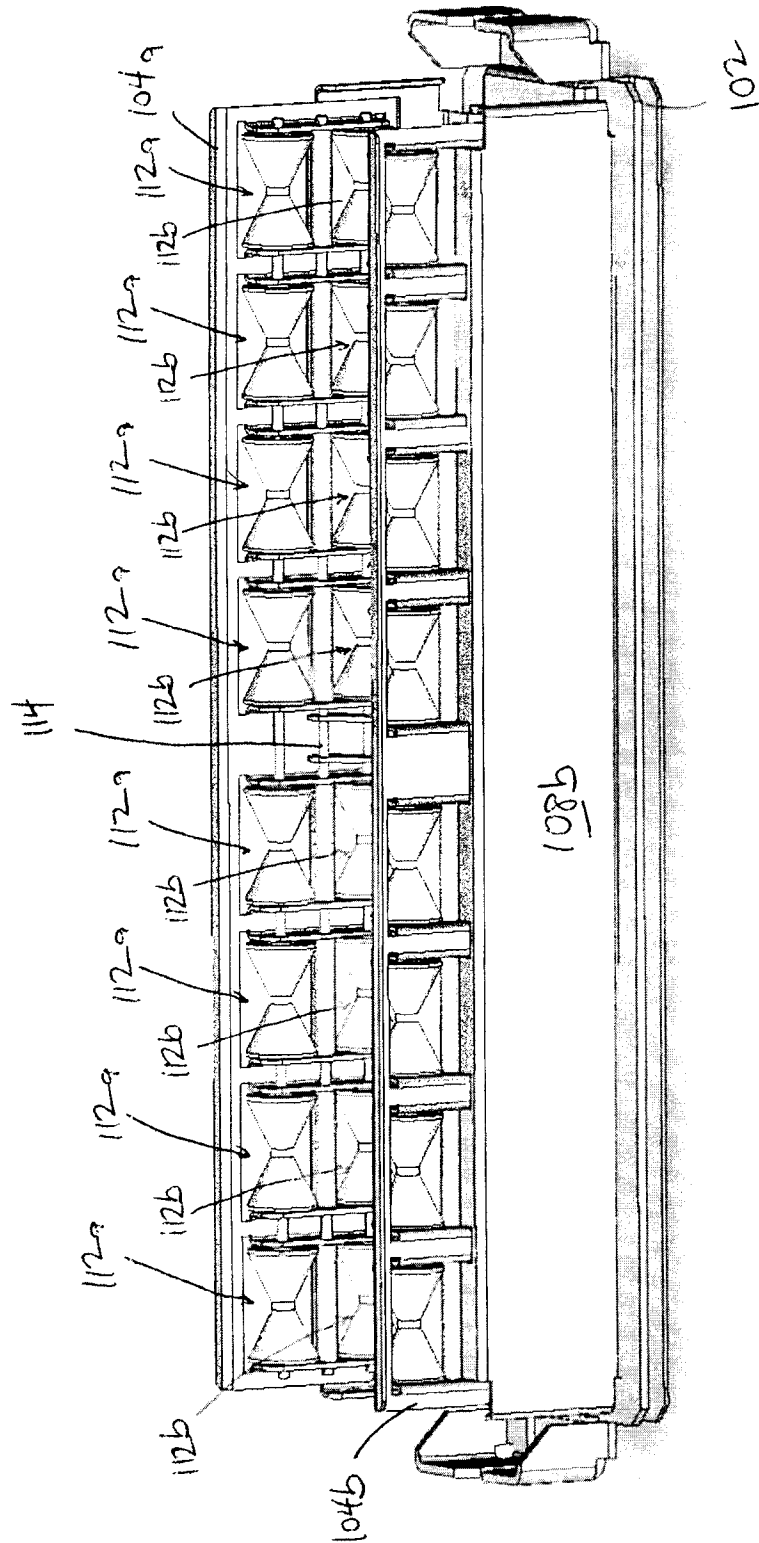

FIG. 3



100

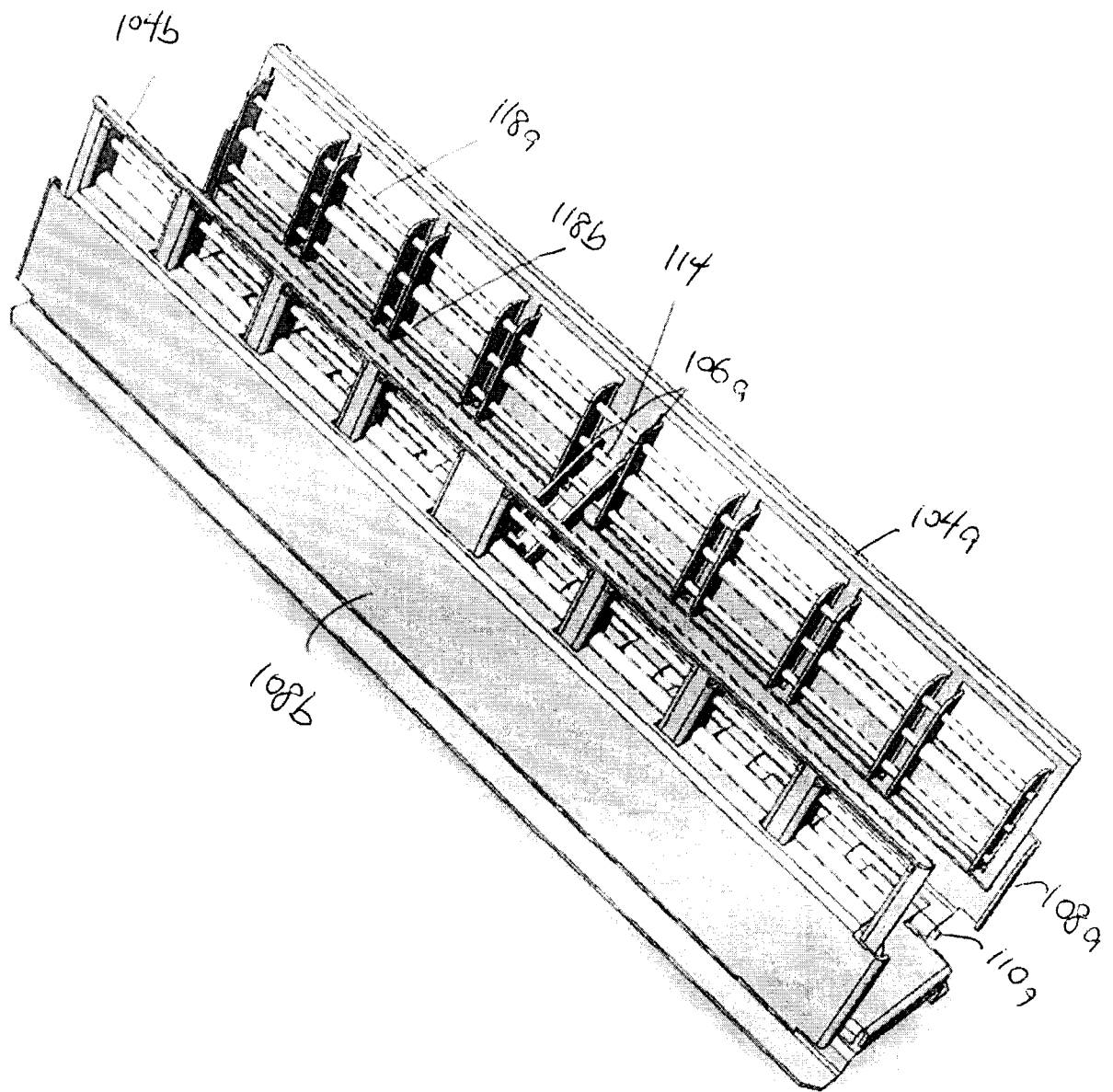

FIG. 5

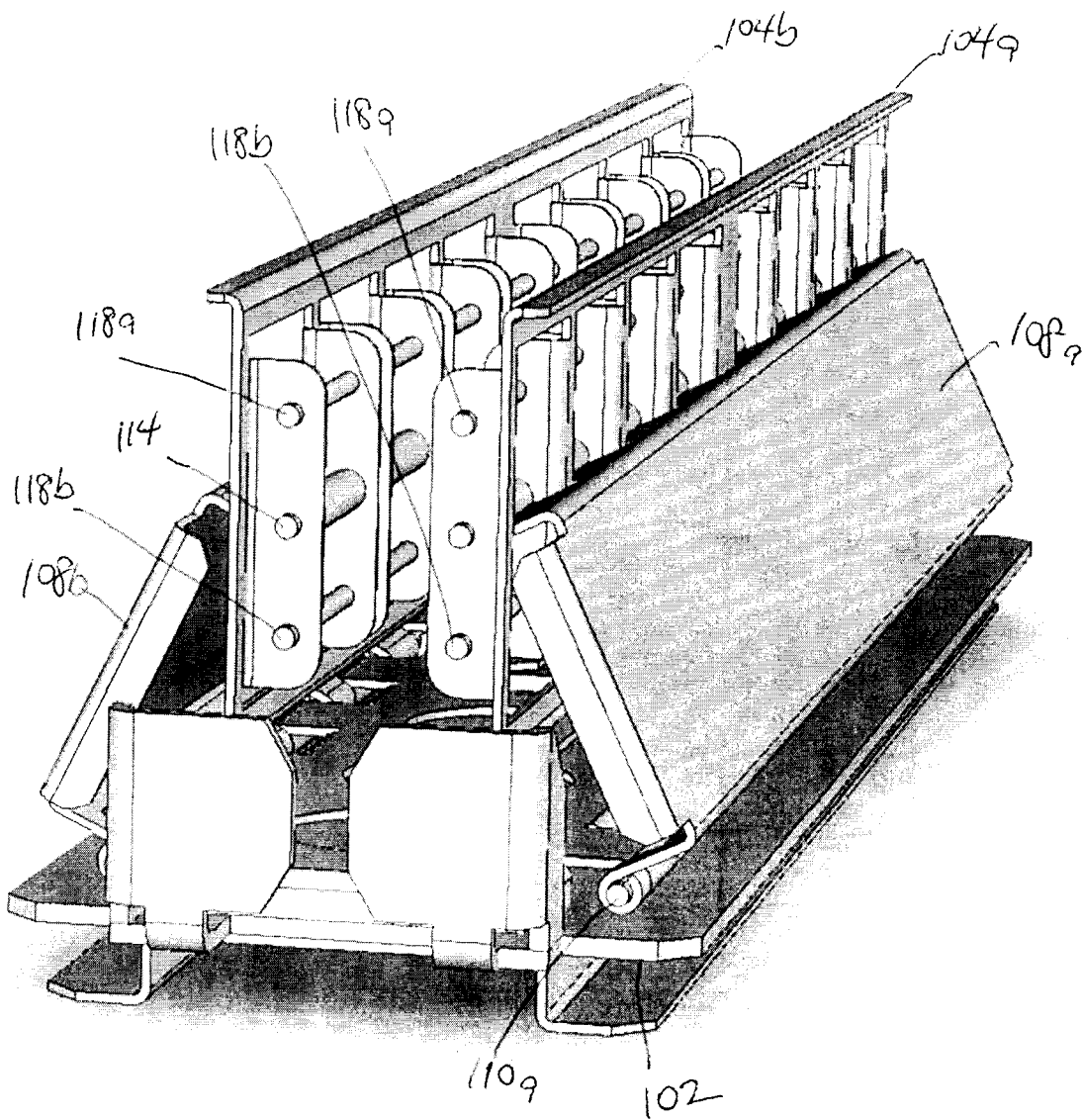

FIG. 6

**INTERNATIONAL SEARCH REPORT**

International application No.  
PCT/CA2009/001642

<p>A. CLASSIFICATION OF SUBJECT MATTER  <b>IPC: B01L 9/06 (2006.01) , B65G 49/00 (2006.01) , G01N 35/00 (2006.01) , G01N 35/04 (2006.01)</b>                  According to International Patent Classification (IPC) or to both national classification and IPC</p>																									
<p>B. FIELDS SEARCHED</p> <p>Minimum documentation searched (classification system followed by classification symbols)  <b>IPC: B01L 9/06, G01N 35/00, G01N 35/04, B65G 49/00. Additional classes searched: IPC: B01L 9, USPC: 422/104, 248/346.04, 248/618, 248.CLAS., 211/74, 211/71.01, 248/441.1</b></p> <p>Documentation searched other than minimum documentation to the extent that such documents are included in the fields searched</p> <p>Electronic database(s) consulted during the international search (name of database(s) and, where practicable, search terms used)  <b>EPOQUE, USWest, Sigma-Aldrich Catalog, Totem Offisource Catalogue. Terms: container, vial, test tube, specimen, bias, spring, hinge, frame wall, roller, pivot</b></p>																									
<p>C. DOCUMENTS CONSIDERED TO BE RELEVANT</p> <table border="1" style="width:100%; border-collapse: collapse;"> <thead> <tr> <th style="width:10%;">Category*</th> <th style="width:60%;">Citation of document, with indication, where appropriate, of the relevant passages</th> <th style="width:30%;">Relevant to claim No.</th> </tr> </thead> <tbody> <tr> <td align="center">X</td> <td>US 6,156,275 B1 (DUMETRESCUE NICOLAE; MAKRCHUK, IRENA (US): BAYER AG (US)) 05 December 2000 (05-12-2005). whole document.</td> <td align="center">1</td> </tr> <tr> <td align="center">X</td> <td>US2006/0284045 A1(CONIBEAR ROBERT ARCHIBALD (US)) 21 December 2006 (21-12-2006). whole document.</td> <td align="center">1</td> </tr> <tr> <td align="center">X</td> <td>Totem Offisource™ Catalogue. (TOTEM OFFISOURCE, (CA)) 01 September 2008 (01-09-2008). pp. 212-216, 357.</td> <td align="center">1</td> </tr> <tr> <td align="center">A</td> <td>US 2005/0207945 A1 (ITOH TERUAKI(JP)) 22 September 2005 (22-09-2005). whole document</td> <td align="center">1-9</td> </tr> <tr> <td align="center">A</td> <td>US 3,871,832 B1 (LEBLANC ADELE (CA)) 18 March 1975 (18-03-1975). whole document</td> <td align="center">1-9</td> </tr> <tr> <td align="center">A</td> <td>US 6, 274, 092 B1 (ITOH TERUAKI(JP)) 14 August 2001 (14-08-2001). whole document.</td> <td align="center">1-9</td> </tr> </tbody> </table> <p><input type="checkbox"/> Further documents are listed in the continuation of Box C.      <input checked="" type="checkbox"/> See patent family annex.</p> <table border="1" style="width:100%; border-collapse: collapse;"> <tr> <td style="width:50%; vertical-align: top;"> <p>* Special categories of cited documents :</p> <p>“A” document defining the general state of the art which is not considered to be of particular relevance</p> <p>“E” earlier application or patent but published on or after the international filing date</p> <p>“L” document which may throw doubts on priority claim(s) or which is cited to establish the publication date of another citation or other special reason (as specified)</p> <p>“O” document referring to an oral disclosure, use, exhibition or other means</p> <p>“P” document published prior to the international filing date but later than the priority date claimed</p> </td> <td style="width:50%; vertical-align: top;"> <p>“T” later document published after the international filing date or priority date and not in conflict with the application but cited to understand the principle or theory underlying the invention</p> <p>“X” document of particular relevance; the claimed invention cannot be considered novel or cannot be considered to involve an inventive step when the document is taken alone</p> <p>“Y” document of particular relevance; the claimed invention cannot be considered to involve an inventive step when the document is combined with one or more other such documents, such combination being obvious to a person skilled in the art</p> <p>“&amp;” document member of the same patent family</p> </td> </tr> </table>			Category*	Citation of document, with indication, where appropriate, of the relevant passages	Relevant to claim No.	X	US 6,156,275 B1 (DUMETRESCUE NICOLAE; MAKRCHUK, IRENA (US): BAYER AG (US)) 05 December 2000 (05-12-2005). whole document.	1	X	US2006/0284045 A1(CONIBEAR ROBERT ARCHIBALD (US)) 21 December 2006 (21-12-2006). whole document.	1	X	Totem Offisource™ Catalogue. (TOTEM OFFISOURCE, (CA)) 01 September 2008 (01-09-2008). pp. 212-216, 357.	1	A	US 2005/0207945 A1 (ITOH TERUAKI(JP)) 22 September 2005 (22-09-2005). whole document	1-9	A	US 3,871,832 B1 (LEBLANC ADELE (CA)) 18 March 1975 (18-03-1975). whole document	1-9	A	US 6, 274, 092 B1 (ITOH TERUAKI(JP)) 14 August 2001 (14-08-2001). whole document.	1-9	<p>* Special categories of cited documents :</p> <p>“A” document defining the general state of the art which is not considered to be of particular relevance</p> <p>“E” earlier application or patent but published on or after the international filing date</p> <p>“L” document which may throw doubts on priority claim(s) or which is cited to establish the publication date of another citation or other special reason (as specified)</p> <p>“O” document referring to an oral disclosure, use, exhibition or other means</p> <p>“P” document published prior to the international filing date but later than the priority date claimed</p>	<p>“T” later document published after the international filing date or priority date and not in conflict with the application but cited to understand the principle or theory underlying the invention</p> <p>“X” document of particular relevance; the claimed invention cannot be considered novel or cannot be considered to involve an inventive step when the document is taken alone</p> <p>“Y” document of particular relevance; the claimed invention cannot be considered to involve an inventive step when the document is combined with one or more other such documents, such combination being obvious to a person skilled in the art</p> <p>“&amp;” document member of the same patent family</p>
Category*	Citation of document, with indication, where appropriate, of the relevant passages	Relevant to claim No.																							
X	US 6,156,275 B1 (DUMETRESCUE NICOLAE; MAKRCHUK, IRENA (US): BAYER AG (US)) 05 December 2000 (05-12-2005). whole document.	1																							
X	US2006/0284045 A1(CONIBEAR ROBERT ARCHIBALD (US)) 21 December 2006 (21-12-2006). whole document.	1																							
X	Totem Offisource™ Catalogue. (TOTEM OFFISOURCE, (CA)) 01 September 2008 (01-09-2008). pp. 212-216, 357.	1																							
A	US 2005/0207945 A1 (ITOH TERUAKI(JP)) 22 September 2005 (22-09-2005). whole document	1-9																							
A	US 3,871,832 B1 (LEBLANC ADELE (CA)) 18 March 1975 (18-03-1975). whole document	1-9																							
A	US 6, 274, 092 B1 (ITOH TERUAKI(JP)) 14 August 2001 (14-08-2001). whole document.	1-9																							
<p>* Special categories of cited documents :</p> <p>“A” document defining the general state of the art which is not considered to be of particular relevance</p> <p>“E” earlier application or patent but published on or after the international filing date</p> <p>“L” document which may throw doubts on priority claim(s) or which is cited to establish the publication date of another citation or other special reason (as specified)</p> <p>“O” document referring to an oral disclosure, use, exhibition or other means</p> <p>“P” document published prior to the international filing date but later than the priority date claimed</p>	<p>“T” later document published after the international filing date or priority date and not in conflict with the application but cited to understand the principle or theory underlying the invention</p> <p>“X” document of particular relevance; the claimed invention cannot be considered novel or cannot be considered to involve an inventive step when the document is taken alone</p> <p>“Y” document of particular relevance; the claimed invention cannot be considered to involve an inventive step when the document is combined with one or more other such documents, such combination being obvious to a person skilled in the art</p> <p>“&amp;” document member of the same patent family</p>																								
<p>Date of the actual completion of the international search</p> <p>19 April 2010 (19-04-2010)</p>	<p>Date of mailing of the international search report</p> <p>27 April 2010 (27-04-2010)</p>																								
<p>Name and mailing address of the ISA/CA</p> <p>Canadian Intellectual Property Office                  Place du Portage I, C114 - 1st Floor, Box PCT                  50 Victoria Street                  Gatineau, Quebec K1A 0C9                  Facsimile No.: 001-819-953-2476</p>	<p>Authorized officer</p> <p><b>ADAM MACKENZIE (819) 994-6514</b></p>																								

**INTERNATIONAL SEARCH REPORT**  
Information on patent family members

International application No.  
**PCT/CA2009/001642**

Patent Document Cited in Search Report	Publication Date	Patent Family Member(s)	Publication Date
US6156275A	05-12-2000	AT271921T	15-08-2004
		DE69825238D1	02-09-2004
		DE69825238T2	28-07-2005
		EP0919281A2	02-06-1999
		EP0919281A3	15-03-2000
		EP0919281B1	28-07-2004
		JP11230969A	27-08-1999
		US6123205A	26-09-2000
<hr/>			
US2006284045A1	21-12-2006	US2006284045A1	21-12-2006
		US7252279B2	07-08-2007
<hr/>			
US2005207945A1	22-09-2005	CN1689549A	02-11-2005
		CN100409944C	13-08-2008
		JP2005262041A	29-09-2005
		JP4056982B2	05-03-2008
		KR20060043706A	15-05-2006
		US7485264B2	03-02-2009
<hr/>			
US3871832A	18-03-1975	US3871832A	18-03-1975
<hr/>			
US6274092B1	14-08-2001	JP2000254526A	19-09-2000
		JP3096685B2	10-10-2000

[continued from Box. No. III]

The claims are directed to a plurality of alleged inventive concepts as follows:

Group A - Claim 1 is directed to a universal container carrier wherein support walls are coupled to a base plate and to a biasing mechanism which is also coupled to the base plate and that moves a support wall to engage a container,

Group B - Claims 2-4 are directed to a container carrier in which the container support is a rotatable support,

Group C - Claim 5 (alone or in part with Group A) is directed to a container carrier in which the support frames are pivotally coupled using a pivoting linkage to a centre portion of the base plate,

Group D - Claims 6-7 (alone or in part with Groups A or B) are directed to a container carrier in which the resilient biasing mechanism is a pair of wings hingedly coupled to the base plate and the support frames

Group E - Claims 8-9 are directed to a container carrier in which the container supports are a pair of rotatable supports.

The claims must be limited to one inventive concept as set out in Rule 13 of the PCT.

An *a posteriori* analysis has concluded that D1, D2, and D3 each disclose the subject matter of claim 1. It appears that claims 2-9 represent different contributions over the art and therefore different alleged inventions.