

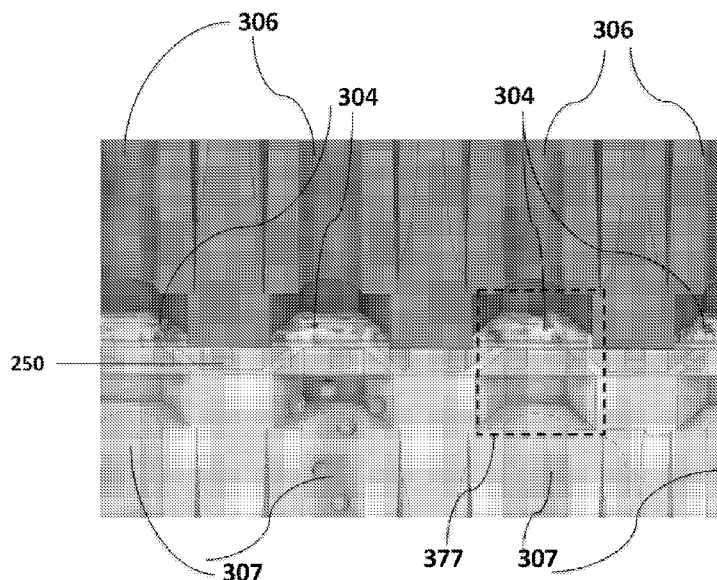

- (51) International Patent Classification:  
*C12M 3/06* (2006.01)      *G01N 1/28* (2006.01)  
*C12M 3/08* (2006.01)      *B25J 9/06* (2006.01)  
*C12N 15/00* (2006.01)
- (21) International Application Number:  
PCT/US2019/021942
- (22) International Filing Date:  
12 March 2019 (12.03.2019)
- (25) Filing Language: English
- (26) Publication Language: English
- (30) Priority Data:  
62/641,425      12 March 2018 (12.03.2018)      US  
62/670,234      11 May 2018 (11.05.2018)      US
- (71) Applicant: **SILICON VALLEY SCIENTIFIC, INC.**  
[US/US]; 6712 Preston St. Suite D, Livermore, California  
94551 (US).
- (72) Inventor: **JOVANOVIĆ, Stevan Bogdan**; 6712 PRES-  
TON STREET SUITE D, LIVERMORE, California 94551  
(US).
- (74) Agent: **STORELLA, John R.**; 2625 Alcatraz Ave. #197,  
Berkeley, California 94705 (US).
- (81) Designated States (*unless otherwise indicated, for every  
kind of national protection available*): AE, AG, AL, AM,  
AO, AT, AU, AZ, BA, BB, BG, BH, BN, BR, BW, BY, BZ,  
CA, CH, CL, CN, CO, CR, CU, CZ, DE, DJ, DK, DM, DO,  
DZ, EC, EE, EG, ES, FI, GB, GD, GE, GH, GM, GT, HN,  
HR, HU, ID, IL, IN, IR, IS, JO, JP, KE, KG, KH, KN, KP,  
KR, KW, KZ, LA, LC, LK, LR, LS, LU, LY, MA, MD, ME,  
MG, MK, MN, MW, MX, MY, MZ, NA, NG, NI, NO, NZ,

(54) Title: METHOD AND APPARATUS FOR PROCESSING TISSUE AND OTHER SAMPLES ENCODING CELLULAR SPATIAL POSITION INFORMATION

Figure 5



(57) Abstract: Provided herein is a system comprising: a) spatial sampler system configured to collect and transmit one or a plurality of cells or nuclei from a tissue specimen, the system comprising: i) a lower carrier having an array of conduits passing therethrough, each conduit comprising an opening on a first side and communicating with an opening on a second side, wherein the opening on the second side either (1) terminates in a capillary or (2) opens onto a well of a multiwell plate; ii) positioned, above the lower carrier, a perforated specimen holder configured to support a frozen tissue specimen, wherein the specimen holder comprises a plurality of perforations having a size sufficient to permit the passage of single cells or nuclei; and iii) positioned, above the specimen holder, a multifunctional head comprising an upper array of upper conduits, optionally, each aligned with a conduit opening of the lower carrier.



OM, PA, PE, PG, PH, PL, PT, QA, RO, RS, RU, RW, SA, SC, SD, SE, SG, SK, SL, SM, ST, SV, SY, TH, TJ, TM, TN, TR, TT, TZ, UA, UG, US, UZ, VC, VN, ZA, ZM, ZW.

- (84) Designated States** (*unless otherwise indicated, for every kind of regional protection available*): ARIPO (BW, GH, GM, KE, LR, LS, MW, MZ, NA, RW, SD, SL, ST, SZ, TZ, UG, ZM, ZW), Eurasian (AM, AZ, BY, KG, KZ, RU, TJ, TM), European (AL, AT, BE, BG, CH, CY, CZ, DE, DK, EE, ES, FI, FR, GB, GR, HR, HU, IE, IS, IT, LT, LU, LV, MC, MK, MT, NL, NO, PL, PT, RO, RS, SE, SI, SK, SM, TR), OAPI (BF, BJ, CF, CG, CI, CM, GA, GN, GQ, GW, KM, ML, MR, NE, SN, TD, TG).

**Declarations under Rule 4.17:**

- *as to applicant's entitlement to apply for and be granted a patent (Rule 4.17(ii))*
- *as to the applicant's entitlement to claim the priority of the earlier application (Rule 4.17(iii))*

**Published:**

- *with international search report (Art. 21(3))*
- *before the expiration of the time limit for amending the claims and to be republished in the event of receipt of amendments (Rule 48.2(h))*

**Title of the Invention:**

[0001] Method and apparatus for processing tissue and other samples encoding cellular spatial position information

**Cross Reference to related applications:**

[0002] This application claims the benefit of the priority date of provisional patent application, 62/641,425, filed March 12, 2018, entitled, "Method and apparatus for processing tissue and other samples encoding cellular spatial position information", and of provisional patent application 62/670,234 filed May 11, 2018, entitled "Method and apparatus for encoding cellular spatial position information", the contents of all are incorporated herein in their entirety.

**Statement of federally sponsored research or development (if any):**

[0003] None.

**The names of the parties to a joint research agreement if the claimed invention was made as a result of activities within the scope of a joint research agreement:**

[0004] None.

**Reference to a "Sequence Listing":**

[0005] None.

**Background of the Invention****[0006] A) Field of Invention**

[0007] This invention relates to the field of sample preparation from biological materials. More specifically, the invention relates to the processing of solid tissues into single cells, nuclei, biomolecules, and processed samples for bioanalysis.

**[0008] B) Description of Related Art**

[0009] Analysis of single cells and groups of cells is now beginning to provide information to dissect and understand how cells function individually and unprecedented insight into the range of individual responses aggregated in ensemble measurements. Single cell methods for electrophysiology, flow cytometry, imaging, mass spectrometry (Lanni, E.J., *et. al.* J Am Soc Mass Spectrom. 2014; 25(11):1897-907.), microarray

(Wang L and KA Janes. Nat Protoc. 2013; 8(2):282-301.), and Next Generation Sequencing (NGS) (Saliba A.E., *et. al.* Nucleic Acids Res. 2014; 42(14):8845-60.) have been developed and are driving an increased understanding of fundamental cellular processes, functions, and interconnected networks. As the individual processes and functions are understood and differentiated from ensemble measurements, the individual information can in turn lead to discovery of how network processes among cells operate. The networks may be in tissues, organs, multicellular organisms, symbionts, biofilms, surfaces, environments, or anywhere cells interact.

**[0010]** Next Generation Sequencing (NGS) of single cells is rapidly changing the state of knowledge of cells and tissue, discovering new cell types, and increasing understanding of the diversity of how cells and tissue function. Single cell NGS RNA sequencing (Saliba A.E., *et. al.*, Nucleic Acids Res. 2014;42(14):8845-60.) (Shapiro E. *et. al.*, Nat Rev Genet. 2013;14(9):618-30.) is unveiling the complexity of cellular expression, and the heterogeneity from cell to cell, and from cell type to cell type (Buettner F. *et. al.*, Nat Biotechnol. 2015; 33(2):155-60.). *In situ* sequencing (Ke R *et. al.*, Nat Methods. 2013;10(9):857-60.), (Lee JH, *et. al.*, Nat Protoc. 2015;10(3):442-58.) (Lee JH, *et. al.*, Science. 2014, 21;343(6177):1360-3.) has shown the feasibility of directly sequencing of fixed cells. However, for RNA, many fewer reads are generated with *in situ* sequencing, biasing against detection of low abundant transcripts. Photoactivatable tags have been used to capture mRNA from single cells (Lovatt, D., *et. al.*, Nat Methods. 2014;11(2):190-6.) from known location in tissue, albeit with low throughput capture and manual cell collection.

**[0011]** The NGS market has grown explosively over the last 10 years with costs reductions and throughput increases exceeding Moore's law. The applications have expanded from whole genome sequencing to RNA-Seq, ChIP-Seq, exome sequencing, to now single-cell sequencing, single nuclei sequencing, and many other exciting applications. The power and low cost of NGS is broadly changing life sciences and moving into translational medicine and the clinic as precision medicine begins. Until recent years essentially all of the NGS analysis was of 'bulk samples' where the nucleic acids of numerous cells had been pooled. There is a need for systems that integrate the sample preparation of single-cell suspensions, and single-cell libraries, and bulk libraries starting from original unprocessed specimens.

**[0012]** Single-cell sequencing is rapidly changing the state of knowledge of cells and tissue, discovering new cell types, and increasing the understanding of the diversity of

how cells and tissue function. Single-cell RNA sequencing (Shapiro E, Biezuner T, Linnarsson S. Single-cell sequencing-based technologies will revolutionize whole-organism science. *Nat Rev Genet.* 2013;14(9):618-30. PMID: 23897237) has highlighted the complexity of cellular expression, and the large heterogeneity from cell-to-cell, and from cell type-to-cell type (Buettner F, Natarajan KN, Casale FP, Proserpio V, Scialdone A, Theis FJ, Teichmann SA, Marioni JC, Stegle O. Computational analysis of cell-to-cell heterogeneity in single-cell RNA-sequencing data reveals hidden subpopulations of cells. *Nat Biotechnol.* 2015; 33(2):155-60. PMID: 25599176). Single-cell sequencing (Wang, Y. and N.E. Navin. Advanced and Applications of single-cell sequencing technologies. *Molecular Cell.* 2015. 58:598-609. PMID 26000845.) is being applied to development, brain structure and function, tumor progression and resistance, immunogenetics, and more.

**[0013]** Single cell nucleic acid sequencing technology and methods using NGS and Next Next Generation Sequencing (NNGS), such as nanopores, are rapidly evolving. Common components are incorporation of a marker or barcode for each cell and molecule, reverse transcriptase for RNA sequencing, amplification, and pooling of sample for NGS and NNGS (collectively termed NGS) library preparation and analysis. Starting with isolated single cells in wells, barcodes for individual cells and molecules have been incorporated by reverse transcriptase template switching before pooling and polymerase chain reaction (PCR) amplification (Islam S. *et. al.* *Genome Res.* 2011; 21(7):1160-7.) (Ramsköld D. *et. al.* *Nat Biotechnol.* 2012; 30(8):777-82.) or on a barcoded poly-T primer with linear amplification (Hashimshony T. *et. al.* *Cell Rep.* 2012 Sep 27;2(3):666-73.) and unique molecular identifiers (Jaitin D.A. *et. al.* *Science.* 2014; 343(6172):776-9.).

**[0014]** Pioneering work has used the power of nanodroplets to perform highly parallel processing of mRNA from single cells with reverse transcription incorporating cell and molecular barcodes from freed primers (inDrop) (Klein A. M. *et. al.* *Cell.* 2015;161(5):1187-201.) or primers attached to paramagnetic beads (DropSeq) (Macosko E.Z. *et. al.* *Cell.* 2015;161(5):1202-14.) and using micronozzles such as described by them or Geng T. *et. al.* *Anal Chem.* 2014;86(1):703-12 or others; the lysis conditions and reverse transcriptase described by (Fekete R. A. and A. Nguyen. United States Patent 8,288,106. October 16, 2012) are incorporated by reference cited therein are incorporated by reference, including instrumentation, chemistry, workflows, reactions conditions, flowcell design, and other teachings. Both inDrop and DropSeq

are scalable approaches have change the scale from 100s of cells previously analyzed to 1,000s and more.

**[0015]** Single-cell sequencing is now providing new information to biologists, genomic scientists, and clinical practitioners, and the single-cell market is growing explosively, perhaps the next great disruption in life sciences and medicine. Multiple companies are providing systems to take single-cell suspensions and create Single-cell RNA sequencing (scRNA-Seq), ATAC-Seq, targeted, and other libraries that are analyzed by the robust NGS sequencing and analysis pipeline. No system integrates the upstream process to produce single-cell suspensions for NGS single-cell sequencing or has integrated from tissue to single-cell libraries.

**[0016]** The production of single-cells or nuclei or nucleic acids from solid and liquid tissue is usually performed manually with a number of devices used without process integration. A combination of gentle mechanical disruption with enzymatic dissociation has been shown to produce single-cells with the highest viability and least cellular stress response (Quatromoni JG, Singhal S, Bhojnagarwala P, Hancock WW, Albelda SM, Eruslanov E. An optimized disaggregation method for human lung tumors that preserves the phenotype and function of the immune cells. *J Leukoc Biol.* 2015 Jan;97(1):201-9. doi: 10.1189/jlb.5TA0814-373. Epub 2014 Oct 30.).

**[0017]** Many manual protocols for dissociating different tissues exist, for example, Jungblut M., Oeltze K., Zehnter I., Hasselmann D., Bosio A. (2009). Standardized Preparation of Single-Cell Suspensions from Mouse Lung Tissue using the gentleMACS Dissociator. *JoVE.* 29, doi: 10.3791/1266; Stagg AJ, Burke F, Hill S, Knight SC. Isolation of Mouse Spleen Dendritic Cells. *Protocols, Methods in Molecular Medicine.* 2001: 64: 9-22. Doi: 10.1385/1592591507.; Lancelin, W., Guerrero-Plata, A. Isolation of Mouse Lung Dendritic Cells. *J. Vis. Exp.* (57), e3563, 2011. DOI : 10.3791/3563; Smedsrod B, Pertoft H. Preparation of pure hepatocytes and reticuloendothelial cells in high yield from a single rat liver by means of Percoll centrifugation and selective adherence. *J Leukocyte Biol.* 1985: 38: 213-30.; Meyer J, Gonelle-Gispert C, Morel P, Bühler L Methods for Isolation and Purification of Murine Liver Sinusoidal Endothelial Cells: A Systematic Review. *PLoS ONE* 11(3) 2016: e0151945. doi:10.1371/journal.pone.0151945.; Kondo S. Scheef EA, Sheibani N, Sorenson CM. "PECAM-1 isoform-specific regulation of kidney endothelial cell migration and capillary morphogenesis", *Am J Physiol Cell Physiol* 292: C2070-C2083, (2007); doi: 10.1152/ajpcell.00489.2006.; Ehler, E., Moore-Morris, T., Lange, S. Isolation and

Culture of Neonatal Mouse Cardiomyocytes. *J. Vis. Exp.* (79), e50154, doi:10.3791/50154 (2013).; Volovitz I Shapira N, Ezer H, Gafni A, Lustgarten M, Alter T, Ben-Horin I, Barzilai O, Shahar T, Kanner A, Fried I, Veshchev I, Grossman R, Ram, Z. A non-aggressive, highly efficient, enzymatic method for dissociation of human brain-tumors and brain-tissues to viable single cells. *BMC Neuroscience* (2016) 17:30 doi: 10.1186/s12868-016-0262-y; F. E Dwulet and M.E. Smith, "Enzyme composition for tissue dissociation," United States Patent 5,952,215, September 14, 1999.

**[0018]** For example, solid tissue of interest is usually dissected and then minced into 1-5 mm pieces by hand or a blender type of disruptor is used. Enzymes or a mixture of enzymes, such as collagenases, hydrauronadase, papain, proteases, DNase, *etc.*, are added and the specimen incubated, typically with shaking or rotation to aid dissociation to prepare single cells or nuclei from tissue. In many procedures, the specimen is titrated multiple times or mechanically disrupted. The mechanical disruption may be through orifices, grinding, homogenization, forcing tissue through screens or filters, sonication, blending, bead-beating, rotors with features that dissociate tissue, and other methods to physically disrupt tissue to help produce single cells.

**[0019]** Following dissociation, in some embodiments the dissociated sample is passed through a filter, such as a 70 micron filter, to retain clumps of cells or debris. The filtrate which contains single cells or nuclei may be further processed to change the media or buffer; add, remove, or deactivate enzymes; concentrate cells or biomolecules, lyse red blood cells, or capture specific cell types. The processing typically involves multiple steps of centrifugation and resuspension, density gradients, or magnetic bead capture of specific cell types using antibodies or other affinity capture ligands, or fluorescent cell-activated sorting (FACS). The titer and viability of the single-cell suspension is usually determined using optical imaging with a microscope and haemocytometer, or an automated instrument. In many cases, the viability is determined using Trypan blue or fluorescent dyes. Quality control can include characterization of the nucleic acids by gel electrophoresis on an instrument such as a BioAnalyzer, or the determination of the expression of certain genes using reverse transcriptase and quantitative polymerase chain reaction (RT-qPCR), or other relevant methods.

**[0020]** The rapid production of nuclei can give a snapshot of gene expression (Habib N, Li Y, Heidenreich M, Swiech L, Avraham-Davidi I, Trombetta JJ, Hession C, Zhang F, Regev A. Div-Seq: Single-nucleus RNA-Seq reveals dynamics of rare adult newborn

neurons. *Science*. 2016 Aug 26;353(6302):925-8. doi: 10.1126/science.aad7038. Epub 2016 Jul 28.; Grindberg RV, Yee-Greenbaum JL, McConnell MJ, Novotny M, O'Shaughnessy AL, Lambert GM, Araúzo-Bravo MJ, Lee J, Fishman M, Robbins GE, Lin X, Venepally P, Badger JH, Galbraith DW, Gage FH, Lasken RS. RNA-sequencing from single nuclei. *Proc Natl Acad Sci U S A*. 2013 Dec 3;110(49):19802-7. doi: 10.1073/pnas.1319700110. Epub 2013 Nov 18.).

**[0021]** The production of nuclei from tissue can be performed using a Dounce homogenizer in the presence of a buffer with a detergent that lyses cells but not nuclei. Nuclei can also be prepared starting from single cell suspensions (CG000124\_SamplePrepDemonstratedProtocol\_-\_Nuclei\_RevB, 10x Genomics, [https://assets.contentful.com/an68im79xiti/6FhJX6yndYy0OwskGmMc8l/48c341c178feafa3ce21f5345ed3367b/CG000124\\_SamplePrepDemonstratedProtocol\\_-\\_Nuclei\\_RevB.pdf](https://assets.contentful.com/an68im79xiti/6FhJX6yndYy0OwskGmMc8l/48c341c178feafa3ce21f5345ed3367b/CG000124_SamplePrepDemonstratedProtocol_-_Nuclei_RevB.pdf)) by addition of a lysis buffer such as 10 mM Tris-HCl, 10 mM NaCl, 3 mM MgCl<sub>2</sub> and 0.005% Nonidet P40 in nuclease-free water and incubation for 5 min on ice before centrifugation to pellet the nuclei followed by resuspension in a resuspension buffer such as 1X PBS with 1.0% BSA and 0.2U/μl RNase Inhibitor. The nuclei may be repeatedly pelleted and resuspended to purify them or density gradients or other purification methods used. The titer and viability of the nuclei suspension is usually determined using optical imaging with a microscope and haemocytometer, or an automated instrument with viability determined using Trypan blue or fluorescent dyes.

**[0022]** The multi-process workflow to produce and characterize single-cells and nuclei from tissue is a usually performed manually using several devices without process integration, limiting the scalability of single cell sequencing and the integration with downstream processes to create a sample-to-answer system. It is laborious and requires skilled technicians or scientists, and results in variability in the quality of the single-cells, and, therefore, in the downstream libraries, analysis, and data. The multiple steps and skill required can lead to differing qualities of single cells or nuclei produced even from the same specimen. Today, the production of high quality single-cells can take months of optimization.

**[0023]** Standardization is necessary before routine single-cell preparation can be performed, particularly in clinical settings. In addition, the length of the process and the process of dissociation can lead to the tissue and cells changing physiology such as altering their expression of RNA and proteins in response to the stresses of the procedure, accentuated by potentially long processing times. A crucial recent insight is

that cell processing methods can alter gene expression by placing cells under stress. For example, the use of protease to dissociate cells from tissue, confounding analysis of the true transcriptome (Lacar B, Linker SB, Jaeger BN, Krishnaswami S, Barron J, Kelder M, Parylak S, Paquola A, Venepally P, Novotny M, O'Connor C, Fitzpatrick C, Erwin J, Hsu JY, Husband D, McConnell MJ, Lasken R, Gage FH. Nuclear RNA-seq of single neurons reveals molecular signatures of activation. *Nat Commun.* 2016 Apr 19;7:11022. doi: 10.1038/ncomms11022. PMID: 27090946.).

**[0024]** Robust, automated sample preparation is required to simplify workflows before full integration can be achieved with downstream NGS analysis to produce true sample-to-answer systems in the future. Robust processes are required that will input a wide range of tissues from a wide range of organisms and tissues and produce high-quality single-cell or nuclei suspensions without intervention, at acceptable viability for suspensions, with minimal changes to gene expression patterns.

**[0025]** To achieve a standardized process will require a system that automates the sample preparation of cells or nuclei (e.g., single cells or single nuclei) from tissue with a single-use disposable cartridge. In some cases, microvalves can be used in cartridges. Microvalves are comprised of mechanical (thermopneumatic, pneumatic, and shape memory alloy), non-mechanical (hydrogel, sol-gel, paraffin, and ice), and external (modular built-in, pneumatic, and non-pneumatic) microvalves (as described in: C. Zhang, D. Xing, and Y. Li., Micropumps, microvalves, and micromixers within PCR microfluidic chips: Advances and trends. *Biotechnology Advances.* Volume 25, Issue 5, September–October 2007, Pages 483–514; Díaz-González M., C. Fernández-Sánchez, and A. Baldi A. Multiple actuation microvalves in wax microfluidics. *Lab Chip.* 2016 Oct 5;16(20):3969-3976.; Kim J., Stockton AM, Jensen EC, Mathies RA. Pneumatically actuated microvalve circuits for programmable automation of chemical and biochemical analysis. *Lab Chip.* 2016 Mar 7;16(5):812-9. doi: 10.1039/c5lc01397f; Samad MF, Kouzani AZ. Design and analysis of a low actuation voltage electrowetting-on-dielectric microvalve for drug delivery applications. *Conf Proc IEEE Eng Med Biol Soc.* 2014;2014:4423-6. doi: 10.1109/EMBC.2014.6944605.; Samad MF, Kouzani AZ. Design and analysis of a low actuation voltage electrowetting-on-dielectric microvalve for drug delivery applications. *Conf Proc IEEE Eng Med Biol Soc.* 2014;2014:4423-6. doi: 10.1109/EMBC.2014.6944605.; Lee E, Lee H, Yoo SI, Yoon J. Photothermally triggered fast responding hydrogels incorporating a hydrophobic moiety for light-controlled microvalves. *ACS Appl Mater Interfaces.* 2014 Oct

8;6(19):16949-55. doi: 10.1021/am504502y. Epub 2014 Sep 25.; Liu X, Li S. An electromagnetic microvalve for pneumatic control of microfluidic systems. *J Lab Autom.* 2014 Oct;19(5):444-53. doi: 10.1177/2211068214531760. Epub 2014 Apr 17; Desai AV, Tice JD, Apblett CA, Kenis PJ. Design considerations for electrostatic microvalves with applications in poly(dimethylsiloxane)-based microfluidics. *Lab Chip.* 2012 Mar 21;12(6):1078-88. doi: 10.1039/c2lc21133e. Epub 2012 Feb 3.; Kim J, Kang M, Jensen EC, Mathies RA Lifting gate polydimethylsiloxane microvalves and pumps for microfluidic control. *Anal Chem.* 2012 Feb 21;84(4):2067-71. doi: 10.1021/ac202934x. Epub 2012 Feb 1; Lai H, Folch A. Design and dynamic characterization of "single-stroke" peristaltic PDMS micropumps. *Lab Chip.* 2011 Jan 21;11(2):336-42. doi: 10.1039/c0lc00023j. Epub 2010 Oct 19).

**[0026]** Fluidic connections between cartridges and the instrument fluidics can be achieved by the use of spring-loaded connectors and modular microfluidic connectors as taught by Jovanovich, S. B. *et. al.* Capillary valve, connector, and router. February 20, 2001. U. S. Patent 6,190,616 and Jovanovich; S. B. *et. al.* Method of merging chemical reactants in capillary tubes, April 22, 2003, U.S. Patent 6,551,839; and Jovanovich, S., I. Blaga, and R. McIntosh. Integrated system with modular microfluidic components. US Patent 7,244,961. July 17, 2007. which are incorporated by reference and their teachings which describe the modular microfluidic connectors and details of modular microfluidic connectors, including their use as multiway valves, routers, and other functions including microfluidic circuits to perform flowthrough reactions and flow cells with internally reflecting surfaces.

**[0027]** The surface chemistries of the paramagnetic beads and conditions to bind cells or precipitate, wash, and elute nucleic acids and other biomolecules onto surfaces is well understood, (Boom, W. R. *et. al.* United States Patent 5,234,809. August 10, 1993.), (Reeve, M. and P. Robinson. United States Patent 5,665,554. September 9, 1997.), (Hawkins, T. United States Patent 5,898,071. April 27, 1999.), (McKernan, K. *et. al.* United States Patent, 6,534,262. March 18, 2003.), (Han, Z. United States Patent, 8,536,322. September 17, 2013.), (Dressman et al., "Transforming single DNA molecules into fluorescent magnetic particles for detection and enumeration of genetic variation" *Proc. Natl. Acad. Sci.* 100(15):8817-8822 (2003)), (Ghadessy et al., "Directed evolution of polymerase function by compartmentalized self-replication", *Proc. Natl. Acad. Sci.* 98(8):4552-4557 (2000)), (Tawfik and Griffiths, "Man-made cell-like compartments for molecular evolution" *Nat. Biotech.* 16(7):652-656 (1998)), (Williams et

al., "Amplification of complex gene libraries by emulsion PCR" Nat. Meth. 3(7):545-550 (2006)), and many chemistries are possible and within the scope of the instant disclosure.

**[0028]** Analysis of single cells is revealing how cells function individually and in groups, and unprecedented insight into the range of cellular behavior, until now aggregated in averaged ensemble measurements. Single cell analysis methods for electrophysiology, flow cytometry, imaging, mass spectroscopy (Lanni EJ, Dunham SJ, Nemes P, Rubakhin SS, and Sweedler JV. J Am Soc Mass Spectrom. 2014 Nov;25(11):1897-907), microarray (Wang L, Janes KA. Nat Protoc. 2013 Feb;8(2):282-301.), and NGS sequencing (Klein AM, Mazutis L, Akartuna I, Tallapragada N, Veres A, Li V, Peshkin L, Weitz DA, Kirschner MW. Cell. 2015 May 21;161(5):1187-201; Macosko EZ, Basu A, Satija R, Nemesh J, Shekhar K, Goldman M, Tirosh I, Bialas AR, Kamitaki N, Martersteck EM, Trombetta JJ, Weitz DA, Sanes JR, Shalek AK, Regev A, McCarroll SA. Cell. 2015 May 21;161(5):1202-14.) are enabling an increased understanding of fundamental cellular processes and functions.

**[0029]** Single cell RNA-Seq (Saliba AE, Westermann AJ, Gorski SA, Vogel J. Nucleic Acids Res. 2014 Aug;42(14):8845-60; Buettner F, Natarajan KN, Casale FP, Proserpio V, Scialdone A, Theis FJ, Teichmann SA, Marioni JC, Stegle O. Nat Biotechnol. 2015 Feb;33(2):155-60.) is unveiling the complexity of gene expression, and heterogeneity from cell-to-cell and from celltype-to-celltype. Pioneering work used nanodroplets to perform highly parallel single-cell mRNA processing with reverse transcriptase incorporating cell and molecular barcodes from freed primers (inDrop) (Klein AM, et al., Cell. 2015 May 21;161(5):1187-201. or primers attached to paramagnetic beads (DropSeq) (Macosko EZ, et al. Cell. 2015 May 21;161(5):1202-14.). These methods change the experimental scale from 100s of cells to greater than 1,000,000 (support.10xgenomics.com/single-cell/datasets). However, all these systems lose spatial information of the location of each individual cell (or groups of cells) in a microenvironment.

**[0030]** *In situ* sequencing has shown the feasibility of directly sequencing fixed cells (Ke R, et al., Nat Methods. 2013 Sep;10(9):857-60; Lee JH, Daugharthy ER, Scheiman J, Kalhor R, Yang JL, Ferrante TC, Terry R, Jeanty SS, Li C, Amamoto R, Peters DT, Turczyk BM, Marblestone AH, Inverso SA, Bernard A, Mali P, Rios X, Aach J, Church GM. Science. 2014 Mar 21;343(6177):1360-3.; Lovatt D, Ruble BK, Lee J, Dueck H, Kim TK, Fisher S, Francis C, Spaethling JM, Wolf JA, Grady MS, Ulyanova AV, Yeldell

SB, Gripenburg JC, Buckley PT, Kim J, Sul JY, Dmochowski IJ, and J Eberwine. Nat Methods. 2014 Feb;11(2):190-6.).

**[0031]** ReadCoor has developed a Fluorescent in situ Sequencing (FISSEQ) instrument for in situ sequencing of tissue sections (World Wide Web site: readcoor.com). However, *in situ* RNA sequencing does not utilize the well developed NGS infrastructure and fewer reads may bias against detecting low abundant transcripts. Nanostring has launched Spatial Genomics which deposits photolabile probes for mRNA or antibodies for protein detection. The instrument optically scans the tissue and selectively releases the probes with a UV laser from regions of interest before capillary transfer of the released probes into a microtiter plate. One limitation is that it only detects the probes that interrogate the tissue and therefore will not discover any new or rare transcripts. (Moncada et al bioRxiv (January 26) 2018; DOI:10.1101/254375). Chen KH, Boettiger AN, Moffitt JR, Wang S, Zhuang X. Science. 2015 Apr 24;348(6233). Multiple chromatin accessibility assays have been developed including scNMT-seq (Clark SJ, Argelaguet R, Kapourani CA, Stubbs TM, Lee HJ, Alda-Catalinas C, Krueger F, Sanguinetti G, Kelsey G, Marioni JC, Stegle O, Reik W. sNat Commun. 2018 Feb 22;9(1):781.), ATAC-Seq (Buenrostro, JD, Giresi, P.G., Zaba L.C., Chang, H.Y. & Greenleaf, W.J. Nature Methods 10,1213–1218 (2013)), and FAIRE-Seq (Bianco S, Rodrigue S, Murphy BD, Gévry N. Methods Mol Biol. 2015;1334:261-72.). Preissl *et. al.* recently demonstrated snATAC-Seq with single nuclei from flash-frozen tissue, albeit without spatial barcodes (Preissl S, Fang R, Huang H, Zhao Y, Raviram R, Gorkin DU, Zhang Y, Sos BC, Afzal V, Dickel DE6, Kuan S, Visel A, Pennacchio LA, Zhang K, Ren B1. Nat Neurosci. 2018 Feb 12. doi: 10.1038/s41593-018-0079-3.). None of the methods, technologies, or products utilize the full potential of the NGS infrastructure to create high-resolution, high-throughput 3D tissue maps from single nuclei. There are now multiple ways to perform single nuclei DNA sequencing including a well based approach to perform  $\phi$ 29 amplification followed by targeted amplification (Leung ML, Wang Y, Kim C, Gao R, Jiang J, Sei E, Navin NE. Nat Protoc. 2016 Feb;11(2):214-235; Leung, ML, Y. Wang, J. Waters, and NE Navin. Genome Biol. 2015; 16(1): 55.).

**[0032]** DNA methylation (5mC) is an epigenetic modification with important regulatory roles. The bisulfite method is well established to discriminate between cytosine and 5-methylcytosine (Luo C, Keown CL, Kurihara L, Zhou J, He Y, Li J, Castanon R, Lucero J, Nery JR, Sandoval JP, Bui B, Sejnowski TJ, Harkins TT,

Mukamel EA, Behrens MM, Ecker JR. *Science*. 2017 Aug 11;357(6351):600-604.) and oxidative bisulfite (Booth MJ, Branco MR, Ficz G, Oxley D, Krueger F, Reik W, Balasubramanian S. *Science*. 2012 May 18;336(6083):934-7.) sequencing can help establish the methylome.

**[0033]** The pioneering work of the Boyden lab has demonstrated expansion microscopy where tissue is expanded about four-fold using an acrylamide polymerization without distortion of cellular and subcellular structures (Chen, F., P W. Tillberg and Edward S. Boyden. *Science*. 2015 January 30; 347(6221): 543–548).

### **Brief Summary of the Invention**

**[0034]** High-throughput data-driven science has given researchers powerful tools to analyze cells, tissues, and organisms including tools to analyze single cells and nuclei. Systems for preparing sequencing samples at the single cell and single nuclei level are now commercially available, connected to the Next Generation Sequencing (NGS) pipeline. The throughput of the NGS systems is enormous and the experimental pipeline is well integrated after processing of cell suspensions through library preparation, sequencing, and bioinformatics. However, for NGS data, the original spatial registration of single cells—where the single cells were found, who their neighbors were, and what the microenvironment was—is usually completely lost.

**[0035]** This invention enables the development and deployment of novel high-throughput spatial systems that enable construction of 3-D maps at single-cell resolution of biomolecules and nucleic acid sequence data from human and other tissues, leveraging the existing NGS infrastructure. The systems will first be used to analyze the spatial distribution of genomic data from nuclei with single-cell resolution from animal and human solid tissue developed for a spatial single nuclei sequencing, ssRNA-Seq, application. Additional applications covering genomic, epigenomic, proteomic analyses can be developed and deployed on this systems platform.

**[0036]** The Spatial Sequencer enables low- or high-throughput automated systems that collect nuclei by 'microregions' (a 'spatial pixel', e.g., around 2, 10, or 150 micron dia.) in known order from solid tissue sections. The microregions are spatially-encoded for single nuclei or single cell NGS by adding DNA barcodes, or for proteomics by adding mass tags or other markers. For sequencing, after processing by the existing single cell and nuclei informatics pipeline, spatial software will decode single nuclei or single cells into single microregions, construct spatial representations of the data, cluster the data with other components and analyze 3D and multidimension images of

multicomponent gene expression or genetic changes in tissue, at single nuclei resolution. The data can be formatted into standardized open data formats for the deposition and storage of data according to standards and compatible with tools for visualizing, searching, and modeling spatial data.

**[0037]** In one embodiment, the Spatial Sequencing system can be comprised of a Spatial Sampler module that processes solid tissue into nuclei or single cells with a known spatial registration and a Spatial Encoder module that adds DNA or other tags to biomolecules from single nuclei or single cells. The systems will process frozen tissue microtome slices using a disposable cartridge. The cartridge may contain the encoding materials to signal the biomolecules' origin. Multiple sections will be processed to obtain 3D mapping information.

**[0038]** A low throughput Spatial Sequencing system can 1) Process microregions to generate single nuclei or single cells in known spatial order in boluses, 2) Add a spatial nucleic acid barcode (and cell and molecule barcodes) to single nuclei or single cells in nanodroplets, boluses, or nanowells to encode the physical origin, 3) Translate the mRNA into cDNA with an integrated spatial barcode, and 4) Process the data to map tissue for ssRNA-Seq and share the findings. The system can be expanded to high throughput, and additional applications and capabilities added including fluorescent imaging of tissue sections.

**[0039]** The Spatial Sequencer is a platform designed to deploy multiple applications that preserve spatial information from solid tissues--gene expression, proteomics, DNA sequencing, lncRNA, epigenomics, methylomics, and almost all other NGS applications--for medical, health, life science research, and other applications. For proteomics and metabolomics, the Spatial Sampler module can process the microregions individually and encode mass standards in known order to the nuclei or to the cellular fluids with the nuclei or single cells removed; MS analysis in either known order or with mass standards (which could be DNA barcodes) can reconstruct the 3D physical coordinates of the proteome or metabolome of the microregions from the tissues. The invention includes MS interfaces adaption of the system to MS and other analytical modalities.

**[0040]** The spatial system enabled herein will give researchers, and ultimately clinicians, a fundamentally new high-resolution, high-throughput, high content capability to characterize single cells, place those data in a geo-located context, revealing the spatial relationships between cells, and how each cell functionally and physically relates

to their near neighbors in the microenvironments. For ssRNA-Seq, the system will encode the positional coordinates of the tissue microsample into spatial DNA barcodes.

**[0041]** The spatial system will process microregions of ca. 10 -100 micron dia. or larger or smaller sizes from solid tissue into spatially encoded information, allowing analysis of small groups or single nuclei by changing the capillary size or expanding the tissue. The microregions can also be preprocessed with spatial information encoded for MS or metabolics. Microregion resolution will provide valuable granular insight into actual cell types, groupings, infiltration, and function in normal and diseased microenvironments. The microregion approach is readily adaptable to sparse high-resolution sampling or to very dense readouts. Microregions can also be split between types of analyzes to provide multidimensional insight, which is hard to do with a single cell.

**[0042]** This invention has fundamental innovations in encoding spatial position information for single nuclei. Compared to *in situ* sequencing, this system applies the full power of NGS analysis. This allows the full range of epigenomic assays to be applied and the use of complementary sequencing platforms, such as the Pac Bio that can recognize a wide range of modified nucleic acids.

**[0043]** The technical innovations this invention enables include: 1) Converting flash frozen tissue into single nuclei or single cells to be spatially mapped by microregions in known order in a scalable tissue mapping system that enables the NGS infrastructure to be quickly applied to understanding tissue structure, function, development, and disease progression, 2) Processing tissue by microregions to encode spatial position with mass and other tags for proteomics, metabolics, and cellomics, 3) expanding tissue to manipulate space for single nuclei spatial sequencing, 4) Integrating the workflow to automate specimen processing.

**[0044]** The Spatial Sequencer can incorporate multiple applications such as single cell DNA sequencing, targeted sequencing, fluorescent tagging and imaging to define areas to be sampled, and extending the workflow to integrate downstream library preparation. An array of technologies for single cell and nuclei biomolecular analysis can be adapted to this platform.

**[0045]** The invention enables processing frozen tissue into nuclei or single cells in a flow stream or on a surface in known spatial order by microregions. The direct processing of solid tissue into nuclei or single cells is compatible with flash frozen tissue, cryopreserved tissue, and fresh tissue. Processing into nuclei can eliminates the

tissue-by-tissue and species-by-species method variations to process solid tissue into single cells.

**[0046]** The spatial technology approach enables many different embodiments and a scaleable instrument, software, chemistry, and disposable cartridges. The system can use a three-axis robot and on-instrument fluidics to process solid tissues into single nuclei spatially encoded libraries. The system can have two main modules which are developed in parallel and then integrated in one embodiment. In this embodiment, the Spatial Sampler module can accept fresh, frozen, formalin fixed paraffin embedded (FFPE), or other tissue on cartridge and converts 1 or more, or 96, or 384 or more microregions into nuclei suspensions that are separated into boluses or nanowells. When the region of interest is in position, the sampler head (part of a multifunctional head) can seals an upper bundle of, for example, 96 conduits, which may be capillaries, microchannels, tubing, *etc.* on the tissue and generate boluses of nuclei in a lower bundle of 96 conduits. For the Spatial Encoder module, commercial single cell encapsulation hardware simplifies the encoder to developing spatially encoded beads and integrating delivery of the beads to boluses with the nozzle fluidics by either timing for open loop or optical detection for closed loop operation.

**[0047]** The Spatial Sequencer system is an integrated and automated sample-to-spatially encoded library system that a specialist can operate to prepare fresh or frozen tissue specimens into libraries for NGS analysis to detect nucleic acids and other biomolecules. In one embodiment, an automated low-throughput spatial system can have automated 'spatial sampling' to collect microregions in known order from solid tissues, barcoding the spatial location into DNA for ssnRNA-Seq analysis, and Integration of sampling and barcoding modules.

**[0048]** In one embodiment, frozen mouse and rat tissue is processed a single microregion at a time into nuclei in a flow and delivering it to a single microfluidic nozzle for scRNA-Seq. The processing can be scaled up to process 12 or 24 or 96 or more microregions in parallel. An automated low throughput prototype-level system to encode the spatial position of tissue for spatial single nuclei RNA-Seq is described.

**[0049]** High-throughput spatial sequencing systems with additional capabilities for imaging, fluid delivery of stains and other reagents to the tissue, and other applications including methylation, barcoded antibodies, and chromatin access applications, as well as epigenomic, proteomic, metabolomic, and systems biology, and other applications are also possible and examples enabled herein.

**[0050]** In one aspect provided herein is a system comprising: a) spatial sampler system configured to collect and transmit one or a plurality of cells or nuclei from a tissue specimen, the system comprising: i) a lower carrier having an array of conduits passing therethrough, each conduit comprising an opening on a first side of the lower carrier and communicating with an opening on a second side, wherein the opening on the second side of the lower carrier either (1) terminates in a capillary or (2) opens onto a well of a multiwell plate; ii) positioned, above the lower carrier, a perforated specimen holder configured to support a frozen tissue specimen, wherein the specimen holder comprises a plurality of perforations having a size sufficient to permit the passage of single cells or nuclei; and iii) positioned, above the specimen holder, a multifunctional head comprising an upper array of upper conduits, optionally, each aligned with a conduit opening of the lower carrier. In one embodiment, the openings on the top side of the lower carrier are configured as wells that communicate with narrower conduits. In another embodiment, the openings on the top side of the lower carrier have a diameter of about 2  $\mu\text{m}$  to about 150  $\mu\text{m}$  e.g., about 100 microns. In another embodiment, the conduits are selected from capillaries, microchannels, tubing, and electrowetting conduits. In another embodiment, a plurality of the conduits each have different lengths, wherein the lengths are determined based on relative spatial position of the conduits in the array. In another embodiment, the lower conduits communicate with a common fluid conduit. In another embodiment, the lower conduits are mated with nozzles leading to a common conduit. In another embodiment, the lower conduits each communicate with a different well or set of wells of a multiwell plate. In another embodiment, the specimen holder comprises a mesh, e.g., a stainless-steel mesh, polymer mesh, metal mesh, strainer, or filter. In another embodiment, the perforations have a diameter of about 20  $\mu\text{m}$  to about 100  $\mu\text{m}$ , e.g., about 20  $\mu\text{m}$  to about 50  $\mu\text{m}$  or about 50  $\mu\text{m}$  to about 100  $\mu\text{m}$ , e.g. about 30 microns. In another embodiment the system further comprises a cryopreserved tissue specimen in the specimen holder. In another embodiment, the multifunctional head has an array of between 12 and 96 conduits. In another embodiment the upper array of conduits is ganged fluidically to a syringe pump configured to deliver one or more solutions (nuclei isolation solution, tissue disruption solution to produce single cells, emulsion oil, or cleaning solution) to a microregion on the specimen carrier. In another embodiment, the system comprises a container of a tissue disruption solution comprising one or more collagenases and/or one or more proteinases and/or a nuclei isolation solution comprising a chemical that

disrupts cell membranes, e.g., comprising a detergent. In another embodiment, the system comprises a temperature controller to control temperature of the specimen holder. In another embodiment, the temperature controller comprises a Peltier. In another embodiment, the multifunctional head comprises at least any of 1, 12, 24, 96, 384 conduits. In another embodiment, the multifunctional head is configured to deliver nuclei isolation solution through the conduits to a tissue specimen positioned on the specimen support. In another embodiment, the multifunctional head is configured to deliver pressure and/or vacuum to the conduits. In another embodiment the system further comprises a movable arm operatively attached to a motor and controlled by a computer (e.g., a robot) that moves the multifunctional head along any dimension of a three-dimensional axis. In another embodiment the system further comprises a motor that moves the multifunctional head along a direction substantially perpendicular to a plane of the specimen carrier, e.g., so as to sandwich a specimen held by the sample carrier between the lower carrier and conduits in the multifunctional head. In another embodiment the system further comprises a computer comprising a processor and memory including code that, when executed by the processor, controls the movement of the multifunctional head and the delivery of pressure or vacuum through the upper conduits. In another embodiment the system further comprises a motor that moves the sample carrier in an X-Y plane parallel to a face of the multifunctional head. In another embodiment, the multifunctional head comprises an imaging station configured to image a specimen on the sample carrier. In another embodiment, the multifunctional head further comprises a dispense head configured to dispense liquids, e.g., imaging reagents or dissociation or other solutions, onto the biological specimen. In another embodiment, the transfer head comprises a plurality of extraction channels where in the extraction channels are arrayed in a two dimensional array (e.g., a line) or a three-dimensional array (e.g., a plane). In another embodiment, the spatial encoder subsystem comprises a plurality of fluidic channels that merge into the encoder channel in which each has an inlet configured to receive the microsamples from an extraction channel. In another embodiment, the transfer membranes have attached thereto a plurality of capture elements, each capture element comprising a particle, which is optionally paramagnetic, having attached thereto one or more antibodies that bind cells in the biological specimen, and nucleic acid markers comprising positional barcodes comprising spatial information where the spatial information identifies the position of the particle on the transfer membranes on the multifunctional head. In another

embodiment, the nucleic acid markers further comprise cell markers identifying the cell to which particle binds, and/or molecular barcodes that differently label different nucleic acid molecules and a single cell. In another embodiment, the nucleic acid markers further comprise cell markers identifying the cell to which particle binds, and/or molecular barcodes that differently label different nucleic acid molecules and a single cell, and the particle comprises a capture sequence such as polyT with a spatial barcode. In another embodiment the system further comprises: b) a spatial encoder subsystem configured to perform a series of biochemical reactions on an emulsion comprising microdrops produced by the spatial sampler system, wherein the spatial encoder subsystem comprises: i) a reaction device comprising an inlet configured to receive microdrops from the spatial sampler subsystem, at least one reaction chamber, and an outlet; ii) a reagent rail communicating with the reaction device through a microchannel and comprising reagent sufficient to perform at least one of biochemical reaction on analytes in the microdrops; iii) one or more pumps configured to move the reagents from the reagent rail through the microchannel to the reaction chamber of the reaction device; and iv) optionally, one or more detectors to sense bolus or fluids to control merging of reagents and specimen. In another embodiment, the spatial sampler system and the spatial encoder subsystem are configured as fluidically communicating modules in the system. In another embodiment, the spatial encoder subsystem further comprising: v) a temperature controller configured to control temperature in the reaction chamber. In another embodiment, the spatial encoder subsystem further comprising: v) a magnet configured to reversibly immobilize paramagnetic particles contained in the reaction chamber. In another embodiment, the biochemical reactions comprise reverse transcription of messenger RNA into cDNA encoding the spatial information. In another embodiment, the biochemical reactions comprise at least: (i) reverse transcription of messenger RNA into cDNA; and (ii) amplification of cDNA. In another embodiment, the biochemical reactions comprise at least: (i) primer extension of a primer hybridized to a DNA template to create an extension product; and (ii) amplification of the extension product.

**[0051]** In another aspect provided herein is a method comprising: a) providing a frozen biological tissue specimen on a sample carrier, wherein cells in the tissue sample have a spatial position in the tissue specimen, and wherein the sample carrier comprises (i) a perforated support that supports the tissue specimen and (ii) an array of passages at addressable positions through the sample carrier and positioned below the

perforated support; b) disrupting cells in the tissue specimen to release one or a plurality of cells or nuclei; and c) collecting a microsample comprising one or a plurality of released cells or nuclei through the perforations into the passages, wherein the addressable position of a passage indicates the original spatial position of the cell or nucleus moved into the passage. In one embodiment, collecting comprises moving cells or nuclei by force, e.g., by pressure, exerted by a liquid, into the passages. In another embodiment the method comprises collecting cells or nuclei from at least one, a plurality, at least 96 or at least 384 different microregions in the tissue specimen. In another embodiment single cells or nuclei are collected per passage. In another embodiment single cells or nuclei are collected into passages from a microregion in the tissue specimen having a largest dimension of about 20 microns to about 150 microns. In another embodiment the method further comprises determining biomolecular information (e.g., proteomic information, nucleic acid sequence information, epigenetic (e.g., methylation pattern, chromatin accessibility, proximal DNA interactions, etc.) from the nuclei collected in each passage. In another embodiment the method further comprises creating a 2-D or 3-D map of the tissue specimen indicating spatial position of biomolecular information (e.g., proteomic information, nucleic acid sequence information, epigenetic) of the tissue. In another embodiment the method further comprises: sectioning a frozen tissue specimen into a plurality of slices; processing each slice according to operation (a) through (c); generating biomolecules from one or more microregions of each slice; and producing a 3-D reconstruction of spatial position of the information in the original tissue specimen. In another embodiment the method further comprises encoding biomolecules collected from each spatial position with positional information tags that indicate the original spatial position of the biomolecules in the tissue specimen. In another embodiment the information tag is a barcoded antibody, a barcoded oligonucleotide or a mass tag. In another embodiment disrupting tissue into one or a plurality of cells or nuclei comprises delivering to the tissue specimen on the platform a nuclei isolation solution (i.e., a solution that disrupts cell membranes, e.g., comprising a detergent) or a tissue disruption solution that produces single cells. In another embodiment the solution is delivered through an array of capillaries positioned above the specimen carrier. In another embodiment the solution is delivered to each of a plurality of microregions, and single cells or nuclei are collected from the microregion, in sequence. In another embodiment disrupting cells comprises physical disruption. In another embodiment the method further comprises delivering

collected single cells or nuclei in boluses into a single flow stream, wherein a position of a bolus in a train of boluses in the flow stream depends on the original spatial position of the single cells or nuclei in the bolus in the tissue specimen. In another embodiment the method comprises collecting a single cell nucleus from each microregion. In another embodiment the method further comprises: d) delivering collected cells or nuclei into wells of a multi-well plate, wherein the position of the wells into which cells or nuclei are delivered depends on the original spatial position of the cells or nuclei in the bolus in the tissue specimen. In another embodiment the method further comprises: d) contacting a collected microsample with a solid particle (e.g., a bead) having attached thereto an oligonucleotide comprising an amplification primer and oligonucleotide barcode sequence, wherein the barcode sequence provides information about the original spatial position of the cells or nuclei in the microsample in the tissue specimen. In another embodiment the method further comprises: d) contacting a collected microsample with a transposon comprising spatial barcodes, which spatial barcodes provide information about the original spatial position of the cells or nuclei in the microsample in the tissue specimen. In another embodiment the method further comprises: d) encapsulating single collected cells or nuclei in low melting point gel beads. In another embodiment the method further comprises: d) treating collecting nucleic acids in the cells or nuclei with bisulfite and determining methylation patterns of the bisulfite-treated DNA.

**[0052]** In another aspect provided herein is method comprising using the system of claim 1 to entrain in a fluidic stream a plurality of microsamples from a biological specimen, wherein the microsamples are contained in spatially separated microdrops or boluses in the fluidic stream and positioned in an order based on their original spatial position within the biological specimen. In one embodiment, the method comprises: a) providing a biological specimen; b) collecting microsamples from one or each of a plurality of different spatial positions in the biological specimen; c) introducing the microsamples in a predetermined order into a fluidic stream in a fluidic channel; d) dividing the fluidic stream into microdrops by introducing boluses of immiscible liquid into the fluidic channel, whereby the microsamples are incorporated into microdrops that are spatially separated from each other in the fluidic stream. In another embodiment the method further comprises: (i) introducing into the fluidic stream a plurality of different spatial markers encoding spatial information, wherein the different spatial markers are incorporated into different microdrops in the fluidic stream, thereby encoding each microdrop with spatial information.

**[0053]** In another aspect provided herein is an article comprising a carrier or cartridge comprising an array of nanowells, each nanowell comprising an oligonucleotide barcode encoding relative position of the nanowell in the array, wherein the oligonucleotide is attached to a wall of the nanowell or to a solid particle comprised in the nanowell. In one embodiment, each nanowell is configured to hold no more than any of 1, 2, 3, 4, 5, 6, 7, 8, 9 or 10 individual nuclei or no more than any of 1, 2, 3, 4, 5, 6, 7, 8, 9 or 10 individual cells. In another embodiment the carrier comprises an array of at least any of 500, 1000, 1500, 2000 or 2500 nanowells.

**[0054]** In another aspect provided herein is a method comprising: a) providing a frozen tissue specimen on a support mesh; b) freeing one or a plurality of cells or nuclei from cells in the tissue specimen while maintaining their spatial relationship; c) moving the freed nuclei into a thin or solid support whereby their spatial information is maintained.

**[0055]** In another aspect provided herein is a method comprising: a) providing a frozen biological tissue specimen on a sample carrier, wherein cells in the tissue specimen have a spatial position in the tissue specimen; b) delivering, with a microsyringe, tissue disruption solution and or nuclei isolation solution to a microregion of the tissue specimen to release one or a plurality of cells or nuclei; c) collecting, with a microsyringe, a microsample comprising one or a plurality of released cells or nuclei; and d) moving the microsyringe with the microsample to a well of multiwell plate or to a spatial encoder module and delivering the cells or nuclei in the microsample. In one embodiment, the microsyringe is controlled by a robotic device. In another embodiment the microsyringe contains spatial barcodes attached to a microsyringe barrel or plunger, or on beads preloaded into the microsyringe or picked up after collection of the microsample and then delivered to a nanodroplet generator.

### **Brief description of the drawings**

**[0056]** The skilled artisan will understand that the drawings, described below, are for illustration purposes only. The drawings are not intended to limit the scope of the present teachings in any way.

**[0057]** **Figure 1** shows a Spatial Sequencer system, including a spatial sampling module and a spatial encoder module, workflows, and applications to process specimens or tissue specimens into biocomponents such as single cells or nuclei encoding spatial position in the bioanalysis.

**[0058]** **Figure 2** shows a Single Cell Spatial Analysis System configured for production of nucleic acid spatial libraries.

**[0059]** **Figure 3** shows a closeup showing the mating of a sampler head and tissue on a stainless-steel mesh carrier over a lower array. The upper array is tilted for the illustration.

**[0060]** **Figure 4** shows a multifunctional head, side and bottom views, with detail of the array.

**[0061]** **Figure 5** shows a concept of a single microregion being processed with an interweaving with the microregion to maximize coverage.

**[0062]** **Figure 6** shows entraining nuclei boluses in a flow system.

**[0063]** **Figure 7** illustrates three embodiments of a spatial sampler cartridge delivering the boluses (A) to nanowells through the lower array of conduits, (B) to an array of wells designed to capture individual nuclei or cells, and (C) directly to an array of nanowells.

**[0064]** **Figure 8A** shows a production of nuclei from flash frozen mouse kidney with incubation in nuclei isolation solution with no mechanical agitation and **Figure 8B** shows the production of nuclei from flash frozen mouse with incubation in nuclei isolation solution after three times passage through 75  $\mu\text{m}$  stainless steel mesh.

**[0065]** **Figure 9** shows nuclei isolation solution does not inhibit RT-qPCR. 1  $\mu\text{L}$  of total RNA from mouse spleen cells and 3.5  $\mu\text{L}$  of nuclei isolation solution or water was added to 5.5  $\mu\text{L}$  of OneStep RT-qPCR master mix with *actB* primers designed for transcripts, and thermocycled.

**[0066]** **Figure 10** shows a schematic of Spatial Encoder module fluidics showing a reagent rail with four barcodes.

**[0067]** **Figure 11** shows a high level process design for beads encoding spatial information.

**[0068]** **Figure 12** shows a cartridge that can input microregions and process single cell or nucleus to encode the spatial information at a single or multi-cell level.

## Detailed Description of the Invention

**[0069]** Machines and methods useful in executing inventions as described herein are disclosed in WO 2017/075,293, published May 4, 2017 (“Method and apparatus for encoding cellular spatial information”) and WO 2018/102,471, published June 7, 2018

("Method and apparatus for processing tissue samples"), the contents of which are incorporated herein in their entirety.

**[0070]** NGS, mass spectrometry, FACS, and other modern high-throughput analysis systems have revolutionized life and medical sciences. The progression of information has been from the gross level of organism, to tissue, and now to single cell analysis. Single cell analysis of genomic, proteomic including protein expression, carbohydrate, lipid, and metabolism of individual cells is providing fundamental scientific knowledge and revolutionizing research and clinical capabilities.

**[0071]** Specimen: The term "specimen," as used herein, refers to an *in vitro* cell, cell culture, virus, bacterial cell, fungal cell, plant cell, bodily sample, or tissue sample that contains genetic material. In certain embodiments, the genetic material of the specimen comprises RNA. In other embodiments, the genetic material of the specimen is DNA, or both RNA and DNA. In certain embodiments the genetic material is modified. In certain embodiments, a tissue specimen includes a cell isolated from a subject. A subject includes any organism from which a specimen can be isolated. Non-limiting examples of organisms include prokaryotes, eukaryotes or archaeobacteria, including bacteria, fungi, animals, plants, or protists. The animal, for example, can be a mammal or a non-mammal. The mammal can be, for example, a rabbit, dog, pig, cow, horse, human, or a rodent such as a mouse or rat. In particular aspects, the tissue specimen is a human tissue sample. The tissue specimen can be liquid, for example, a blood sample, red blood cells, white blood cells, platelets, plasma, serum. The specimen, in other non-limiting embodiments, can be saliva, a cheek, throat, or nasal swab, a fine needle aspirate, a tissue print, cerebral spinal fluid, mucus, lymph, feces, urine, skin, spinal fluid, peritoneal fluid, lymphatic fluid, aqueous or vitreous humor, synovial fluid, tears, semen, seminal fluid, vaginal fluids, pulmonary effusion, serosal fluid, organs, bronchio-alveolar lavage, tumors, frozen cells, or constituents or components of *in vitro* cell cultures. In other aspects, the tissue specimen is, without limitation, a solid tissue sample or a frozen tissue sample or a formalin fixed paraffin embedded (FFPE) tissue sample or a cryopreserved tissue sample or a biopsy sample such as a fine needle aspirate or a core biopsy or a resection or other clinical or veterinary specimen. In still further aspects, the specimen comprises a virus, bacteria, or fungus. The specimen can be an *ex vivo* tissue or sample or a specimen obtained by laser capture microdissection. The specimen can be a fixed specimen, including as set forth by U.S. Published Patent Application No. 2003/0170617 filed Jan. 28, 2003.

**[0072]** Conduits can be comprised of single capillaries, 3D printed cartridges, microchannels, tubing, microchips, fluidic connections, valves, routers, and other fluidics for flowthrough and nanowell approaches.

**[0073]** Bulk analysis is used to describe the analysis of a pool of analyte from more than one single cell or nucleus; for example, RNA-Seq is bulk analysis as distinct from scRNA-Seq analysis. Similarly, bulk sample preparation refers to sample preparation of samples that have pooled single cells and nuclei.

**[0074]** In some embodiments, the single cells can be analyzed further for biomolecules including one or more polynucleotides or polypeptides or other macromolecules. In some embodiments, the polynucleotides can include a single-stranded or double-stranded polynucleotide. In some embodiments, the polypeptide can include an enzyme, antigen, hormone or antibody. In some embodiments, the one or more biomolecules can include RNA, mRNA, cDNA, DNA, genomic DNA, microRNA, long noncoding RNA, ribosomal RNA, transfer RNA, chloroplast DNA, mitochondrial DNA, or other nucleic acids including modified nucleic acids and complexes of nucleic acids with proteins or other macromolecules.

**[0075]** It should be understood that the description and the drawings are not intended to limit the invention to the particular form disclosed, but to the contrary, the intention is to cover all modifications, equivalents, and alternatives falling within the spirit and scope of the present invention as defined by the appended claims. Further modifications and alternative embodiments of various aspects of the invention will be apparent to those skilled in the art in view of this description. Accordingly, this description and the drawings are to be construed as illustrative only and are for the purpose of teaching those skilled in the art the general manner of carrying out the invention. It is to be understood that the forms of the invention shown and described herein are to be taken as examples of embodiments. Elements and materials may be substituted for those illustrated and described herein, parts and processes may be reversed or omitted, and certain features of the invention may be utilized independently, all as would be apparent to one skilled in the art after having the benefit of this description of the invention. Changes may be made in the elements described herein without departing from the spirit and scope of the invention as described in the following claims. Headings used herein are for organizational purposes only and are not meant to be used to limit the scope of the description.

**[0076]** The Spatial Sequencer **100**, as illustrated in one embodiment in **Figure 1**, is a platform technology for spatially encoding biomolecules for readout by analytical platforms including NGS and MS. A low throughput embodiment for spatial single nuclei RNA-Seq with Spatial Sampler **300** and Spatial Encoder **400** modules is described as well as high throughput embodiments with imaging, library preparation, and additional genomic and proteomic applications. This low throughput system embodiment can process tissue into samples that have encoded the spatial position information for single nuclei or single cell RNA-Seq, ATAC-Seq, or many other single cell or nucleus, and bulk applications.

**a. Spatial Sampler.**

**[0077]** Referring to **Figure 1**, the Single Cell Spatial Analysis System **100** accepts specimens **301** and processes one or more microsamples **125** from selected microregions **304** to encode the physical location of the microsample **125** within the specimen **301** to produce spatially encoded single cells or nuclei **1000** in microdrops, e.g., nanodroplets or boluses, by adding a marker such as a DNA barcode that encodes for the location of the microsample **125**. Known markers are added in known order to ordered microsamples **125** to encode the spatial position. Analysis method **1100**, such as DNA sequencing, mass spectrometry, or other analytical methods, generates single cell analytical data **1600**, such as DNA sequence or proteomics, and also decodes the encoded spatial information to produce decoded single cell spatial information **1500**. Multiple sample preparation and analytical methods can be used on a specimen. In some aspects where the biomolecules are nucleic acids, the downstream processes can include without limitation, nucleic acid sequencing, targeted resequencing, genotyping analysis, mutation analysis, copy number variation assessment, allele frequency assessment, plasmid construction, cloning, and the like. The decoded single cell spatial information **1500** identifies the spatial position **130** where microsample **125** originated in specimen **301**. The single cell analytical data **1600** is analyzed by single cell spatial analysis **2000** software to produce single cell spatial information **3000** which has the analytical data and associated physical position information of the microsample **125**.

**[0078]** Referring to **Figure 2**, in an embodiment, configured for nucleic acid analysis, specimen **301** is placed in a specimen holder **310** which is inserted into the Spatial Sampler module **300** by loading mechanism **305**. Specimen holder **310** may be temperature controlled, critical for cryosections. The loading mechanism can have a

mechanical slide, stage, pneumatic actuator, or other mechanism, that accepts specimen holder **310** and moves it into the Single Cell Analysis System **100**, either automated or manually, into a fixed position in the Spatial Sampler module **300** or other mechanism. Spatial Sampler module **300** can have a three axis stage **320** that moves a multifunctional head **330** in the x, y and z directions to collect microsamples **125** in a spatially defined manner from specimen **301** at capture position **345** and dispenses the collected microsamples **125** at dispense position **350** into input device **360**. In some embodiments the fluidics of the Single Cell Spatial Analysis System **100** are incorporated onto cartridge(s) **4000**, described later.

**[0079]** Referring to **Figure 3**, in one embodiment, microregions **304** are mechanically defined by the upper array of fluidic conduits **306** of a sampler head (**Figure 3**) and then fluidically injected into a lower array of fluidic conduits **307** and into a fluidic stream for downstream nanodroplet or into an array of nanowells **320** for spatial encoding of single nuclei or single cells. Other alternative embodiments include micropunching the microregions and using pick-and-place robotics to sort the microregions into microtiter or other multiwell plates.

**[0080]** In an embodiment, a fully integrated low throughput spatial system can process cryosections into single nuclei spatially encoded cDNA, ready for processing into a NGS library. In another embodiment, a fully integrated low throughput spatial system can process cryosections **303** into single cells and produce spatially encoded cDNA, ready for processing into a single cell NGS library. In other embodiments, the approach is applied to cellomics and proteomics by adding barcoded antibodies or mass tagged internal standards with collaborators. To scale encoding, a commercial single channel micronozzle can be adapted to inject, e.g., 12 spatial barcoded beads at the proper timing to encode 12 microregions, allowing 8 micronozzles (one run on many systems) to process 96 microsamples.

***Spatial Sampler technology to generate nuclei from microregions of frozen tissue sections.***

**[0081]** The Spatial Sampler module **300** can process a cryosection **303** into cell or nucleus suspensions from separate microregions in known order either into boluses **308** or into nanowells **319**. As shown in **Figure 4**, in one embodiment, the Spatial Sampler module **300** can have a moveable multifunctional head **330** that can be moved by a two-axis stage to regions of interest to sample. In one embodiment, the multifunctional head **330** will have an array of conduits, e.g., 24 capillaries, ganged fluidically to a syringe pump that can deliver solutions (nuclei isolation solution, dissociation solutions to

produce cells, emulsion oil, or cleaning solution) to the section on a specimen holder **310 (Figure 3)**, e.g., a stainless steel mesh carrier **250**, as shown in **Figure 5**, through a disposable matched array of openings in the multifunctional head (above) and lower carrier (below) (together forming an 'eggcrate' **377**) that defines the microregions **304**.

**[0082]** In one embodiment, the module can work as follows. Referring to **Figure 3** and **Figure 5**, A cryosection **303** on a specimen holder **310** which may be a disposable carrier in a cartridge is input on a temperature-controlled two-axis stage and positioned over a lower array of conduits **307** which may be an array of capillaries **318**. The specimen holder **310** can be a perforated substrate **250**, e.g., a mesh or strainer mesh comprising metal, stainless steel, plastic, polymeric, fiber, or other meshes with pore sizes preferably greater than 5 microns to an embodiment at 30 microns to over 70 microns, or strainer with pores between about 20  $\mu\text{m}$  to about 50  $\mu\text{m}$ , e.g. about 30  $\mu\text{m}$  for nuclei or about 50  $\mu\text{m}$  to about 100  $\mu\text{m}$ , e.g. about 70 microns for cells, or adjusted to the specimen tissue type and process.

**[0083]** The stage moves the section below the multifunctional head **330**. The multifunctional head **330** will then lower an upper array of conduits **306**, for example, capillaries (e.g., 100 micron ID/176 micron OD (Polymicro, 106815-1818, TSP300665), over the region of interest to match the lower array of conduits **307**, sandwiching the cryosection **303** on mesh **250** between the upper and lower arrays of conduits. In one embodiment, the upper array of conduits **306** defines the microregions **304** as it is lowered onto cryosection **303**.

**[0084]** The terms upper array of conduits **306** and lower array of conduits **307** may also refer to a single upper or lower or both conduits.

**[0085]** In an embodiment, the upper and lower conduits may align to microns, such as less than 25 microns, and be in close to exact alignment. In an exact alignment, fluid paths from each conduit upper array of conduits **306** through cryosection **303** on specimen holder **310** into the lower array of conduits **307** are direct, once the cryosection **303** or specimen **301** has dissociated the tissue in each microregion **304** into single cells or nuclei, and the fluid flows from the upper array of conduits **306** directly into the lower array of conduits **307**.

**[0086]** The movement of upper array of conduits **306** and lower array of conduits **307** need not be exact; in some embodiments; for example without limiting, since the upper array of conduits **306** in the described embodiment defines the microregions **304** as it is lowered onto cryosection **303**, and in some embodiments the specimen **301** is

dissociated into an array of nanowells **320** and the absolute position of the array of nanowells **320** need not exactly match with the upper array of conduits **306**.

**[0087]** Referring to **Figure 6** in one embodiment, cartridge **4300** contains the lower array of conduits **307** as an array of capillaries **328**. In another embodiment, below array of conduits **307** is an array of nanowells **320** as shown in **Figure 7**.

**[0088]** The multifunctional head **330** then delivers nuclei isolation solution **910** from the upper array of conduits **306** through a changeable liquid permeable membrane (not shown) to the tissue section held on the cartridge **4300**. The nuclei isolation solution **910** (e.g., 10 mM TrisHCl, 25 mM KCl, 250 mM sucrose, 5 mM MgCl<sub>2</sub>, 0.1% Nonident P-40) or other formulations disrupt cellular membranes to generate nuclei as the tissue is simultaneously forced through the 30 micron mesh filter and into a carrier with an lower array of conduits **307** connecting to capillaries or other channels geometrically matching the upper array of conduits **306** or to an array of nanowells **320** on the bottom of the cartridge **4000**. If needed, the nuclei isolation solution **910** can be forcibly moved up and down to fluidically disaggregate the cryosection **303**, the concentration of detergent increased, or the contact time lengthened before higher pressure is applied. Physical features to disrupt the tissue can be used.

**[0089]** In one embodiment, this method will produce a bolus of 30 micron strained nuclei in suspension in the nuclei isolation solution **910** from each individual microregion **304**, for example, 150 micron diameter and 5 to 50 micron deep. Each capillary or nanowell collects only one microregion **304** per tissue slice. Depending on the size of the conduits, or capillaries, these microregions **304** may contain a few or tens of cells, all from the same physical location, all sharing the same microenvironment.

**[0090]** As shown in **Figure 6** for a microflow approach, cartridge **4300** contains the lower array of conduits **307** which is an array of capillaries **318** made with different lengths connecting at a valve such as FROLC valve which can join multiple flows. (See, e.g., U.S. patent 7,244,961.) Because the capillaries have different lengths, a series of boluses **308** at controlled intervals in a single flow stream can be produced. A flush of the flow stream with an immiscible fluid followed by flow from the multifunctional head upper array of conduits **306** will produce boluses **308** in flow stream. Each capillary can feed individual nanodroplet generators with a single 'spatial' barcode to generate spatially defined microsamples from tissue for output into the Spatial Encoder module **400**. After cleaning, a new section can be loaded and the same region of interest can

be sampled and barcodes tied to the next 3D layer can be added to reconstruct a 3D representation by sections.

**[0091]** In another embodiment, as shown in **Figure 7A**, cartridge **4300** contains the lower array of conduits **307** which separately enter individual chambers **328** which may each contain an array of nanowells **320**; the array, **320**, of nanowells, **319** can include spatial barcodes attached to the walls with DNA primers. One alternate embodiment uses oligo-encoded nanowells that may be arranged in larger chambers. Ninety-six microregions could be processed in 96 separate individual chambers **328** each with a array of nanowells **320** to isolate single nuclei. In another embodiment, beads containing spatial barcodes could be added during manufacturing and the spatial barcodes interrogated to readout the spatial barcodes.

**[0092]** In another embodiment, as shown in **Figure 7B**, cartridge **4300** contains the lower array of conduits **307** which separate enter individual chambers **328** which each contain an array of holes **325** mounted in the middle of individual chambers **328**. The array of holes **325** can be an array of capillaries **318** or may be injection molded with opening that may be 30 microns in diameter, or larger, or smaller. By positioning the array of holes **325** above the bottom of individual chambers **328**, single cells or nuclei can be trapped on the array of holes **325** and reaction mixtures added directly to the array of holes **325** to perform chemical or biochemical reactions. The individual chambers can have optional fluidic input **326** and fluidic output **327** to allow reactants or buffers to be added.

**[0093]** In another embodiment, as shown in **Figure 7C**, cartridge **4300** has the array of nanowells **320** directly integrated into the cartridge replacing the lower array of conduits **307**.

**[0094]** In another embodiment, to produce single cells, the upper array of conduits **306** delivers a tissue specific dissociation formulation to specimen **301** which can be a cryopreserved tissue **303** and after an incubation, the dissociated cells from microregions **304** are delivered to the Spatial Encoder **400** for flowthrough or nanowell processing.

**[0095]** **Figure 8A** shows results of processing flash frozen mouse liver that had been finely manually sectioned and incubated with nuclei dissolution solution **920** produced nuclei at room temperature with no mechanical processing. The finely sectioned flash frozen liver had a nuclei isolation solution **920** added and then after seven minutes a sample was taken, and ten  $\mu$ l of the sample was mixed with ten  $\mu$ l of Trypan blue,

loaded onto a disposable hemocytometer, and visualized on a brightfield microscope. This result is proof-of-concept of producing nuclei from thin slices of frozen tissue with no mechanical disruption. **Figure 8B** shows the results of processing 1 mg frozen slice of liver with nuclei dissolution solution **920** that has been fluidically driven through a 75  $\mu\text{m}$  stainless steel mesh **250** three times and then visualized and counted on a hemocytometer: the 1 mg frozen slice produced well defined nuclei after passage through the mesh.

**[0096]** To test if the nuclei isolation solution **910** impacted downstream nucleic acid enzymology, mouse spleen RNA was processed by RT-qPCR (qScript XLT One-Step RT-qPCR ToughMix Rox, QuantaBio) with or without undiluted nuclei isolation solution. **Figure 9** shows neither the reverse transcriptase nor the DNA polymerase were inhibited by the nuclei isolation solution, suggesting it will not inhibit downstream molecular biology, possibly obviating the need to change buffers and simplifying the workflow.

**[0097]** Extensive quality control (QC) assays can be carried out to quantify performance in singulating nuclei as metrics to assess and tune the module development. Quality control assays for tissue into cells and nuclei dissociation for titer and viability can use an automated cell counter, such as the Countess II FL (Thermo Fisher) or microscopy, as well as RT-qPCR for the *actB* housekeeping gene and *fos*, a stress induced gene. For RNA quality, after cDNA production, the size distribution can be measured (Bioanalyzer, Agilent) and qPCR performed on housekeeping and key marker genes from specific cell types to determine RNA integrity. RT-qPCR assays can have ERCC spike-in controls and additional controls for processing steps including additional spiked in controls, with for example, different barcodes or mass tags, for each processing step. These controls can be used to tune processing parameters. NGS can also be used, for example cDNA libraries can be constructed using micronozzles, and after library preparation, scRNA-Seq carried out on Illumina or other instrumentation. Gene coverage analysis can reveal the percent of full length cDNA recovered and any excess coverage at the 3'-end of genes indicating the harshness of tissue processing methods.

**[0098]** A very low throughput embodiment can produce microregions from frozen tissue. Two machined mating holders each that has a single 100 micron/188 micron OD capillary, and 'eggcrate' **377** adapters to hold the capillary can be made with lower one fixed and in one embodiment chilled by a Peltier. The upper one can be held on a

micromanipulator 3-axis stage, engaged at the top with the upper capillary attached a syringe pump at the other end.

**[0099]** Tissue can be placed in the carrier and the upper holder lowered to define a single microregion. The syringe pump can then deliver nuclei isolation solution **920** through the upper capillary to the tissue and a microregion **304** can be collected, such as into a single microfuge tube for RT-qPCR analysis or for bulk and single nuclei sequencing. Multiple microregions **304** can be pooled for processing or the size of the microregion changed. The scale can be increased to 12 and then 24 microregions in parallel with the Spatial Encoder **400** developed to multiplex 12 barcodes.

**[00100]** Different mouse or rat tissues can be tested to measure the variability from tissue to tissue for flash frozen tissue; for fresh tissues, little variability has been observed from tissue to tissue for production of nuclei for soft tissues, while large variations exist for the production of single cells (unpublished observations).

**[00101]** Leakage can be resolved with gasket and cartridge design; note leakage between microregions will not overly confound the data analysis. Speed of production can be adjusted with detergent concentration, temperature, and added mechanical forces. Cell debris, and ambient nucleic acids can also lower the performance and quality metrics of the resulting NGS data and may require additional processing such as removal by in-line tangential flow filtration. The design of the carrier and the workflow (time of exposure, temperature, pressure, detergent and additive concentrations) can be iterated to improve performance. Alternative methods of microscale punching of microregions into microtubes, pick-and-place robotics to move produced microregions into microtiter plates, and incorporating labels in the can be employed.

**[00102]** The hardware, electronics, chemistry, cartridge, and software of the Spatial Sampler module are described. The software can use LabScript™ software (McIntosh Analytical) to control motors through boards and temperature using Peltiers or other devices comprising resistive heaters, chillers, or others.. Three OEM stages can be used to move the section carrier and multifunctional head and affixed to an instrument chassis. The specified positional accuracy can be 2 micron with travel of 10 cm for two axes and < 1 cm for the third (Z). The stages can be controlled by LabScript software with scripts written for the needed motions or other software. In one embodiment, the multifunctional head can have an array of capillaries **318** that inject nuclei isolation solution **920** at 24 to 96 injection points from the array on the multifunction head through the tissue on the carrier. A 3D printed multifunctional head can be held by the three

axis robot through a support that will also bring the fluidics **339** from syringe pumps to the upper array of capillaries in the multifunctional head.

**[00103]** For the microflow approach, the upper holder can, as needed, pick up a disposable liquid permeable membrane to minimize contamination. The carrier would be as simple as a supported mesh or could include the 'eggcrate' **377** and a bottom alignment feature to dock with the lower array.

**[00104]** A Spatial Sampler module can have an 1, 12, 24, 96, 384 or other channel array head. A cleaning cycle can be developed, with 100 mM NaOH, followed by a buffer rinse, and airflow to dry the capillaries or other methods. Contamination of the reusable components can be measured by alternating species and assaying with qPCR and sequencing. The Spatial Sampler module can be scaled up to 96 capillaries and to 384 or more.

**[00105]** **Flowthrough spatial encoding of microregions from frozen tissue.**

**[00106]** The microflow Spatial Encoder module **400** inputs ordered single nuclei from microregions from the Spatial Sampler module **300** and encodes the spatial origin of the nuclei into DNA for ssnRNA-Seq. This is done by adding beads with known barcodes (or mass tags for proteomics) to each bolus to correlate with the original spatial information as nanodroplets are made.

**[00107]** For ssnRNA-Seq, the cells are lysed and the mRNA **681** hybridized **682** and reverse transcribed **683** to encode the spatial information as a barcode in the cDNA **684**. The cDNA now contains spatial, cellular, and molecular barcodes in addition to any sequencing and amplification primers, *i.e.*, T7, PCR. The samples can be pooled for library preparation and analysis for NGS sequencing.

**[00108]** One embodiment of the hardware, beads, and workflows to introduce single nuclei or single cells and process them into nanodroplets **325** or surfaces to encode spatial position is described. For a large part of the workflow, single to 8 to 96 micronozzle systems are available. A brute force production system could mate the 96 capillaries from the Spatial Sampler module to a Telos System (Dolomite) with 96 nozzles using 12 chips, each with 8 micronozzles.

**[00109]** As shown in **Figure 10**, in one embodiment the Spatial Encoder cartridge **4400** can introduce spatial barcodes on the beads into nozzle **429** to produce cell or nuclei nanodroplets **325** in lysis/RT mixture, with all or most of the cells or nuclei having a bead with a spatial barcode. Detection region **450** can be interrogated to detect bolus

**308** as it approaches nozzle **429** to place beads with spatial barcodes in proper position to merge with individual boluses **308**.

**[00110]** If Spatial Encoder cartridge **4400** connects to 12 spatial barcodes, then only one cartridge of 8 micronozzles is needed to tag 96 microregions **304**. The spatial barcode can include additional indexes to identify each nozzle for 2D reconstruction and for each layer or section number for 3D reconstruction. This approach is very scaleable. An issue is the delivery of the 12 spatially encoded bead sets into the fluidic stream and into the 'bead feed' at the proper timing and changing the beads on demand. This can be addressed by adjusting the gap between boluses of microregions in the Spatial Sampler module and by detecting boluses with an optical sensor or imager to trigger the proper bead batch. The gaps can be made very long or short as needed.

**[00111]** As shown in **Figure 11**, for ssRNA-Seq, oligonucleotide-functionalized beads or nanowells can have a poly T sequence to capture polyadenylated mRNA. The oligos will be barcoded for spatial information (by the lot of each set of barcodes and the sample they were added with) as well as cell and molecule identification and amplification and sequencing primer sequences.

**[00112]** Oligonucleotides can be designed to provide 1,024 barcodes with 5 bases of spatial barcodes for spatial resolution (including layer) and QC barcodes. Cell barcodes can be 6 nucleotides that are synthesized by split-pool and UMIs can be 8 nucleotides by degenerate synthesis; the cell barcodes only need to identify within a microsample/bolus (the spatial barcode discriminates against all cells outside the microregion). The oligos, such as amino-modified oligonucleotides, will be initially attached to commercially available paramagnetic beads or nanowells by covalent crosslinking or biotin. The oligo sequence can be evaluated for proper functioning and additional spacers added as needed to minimize bead/surface reaction interferences.

**[00113]** In one embodiment, the hardware and software must deliver beads with a unique, known, spatial barcode to each microsample in the flowthrough approach. The fluidic delivery will use a reagent rail to access beads each with a single spatial barcode as shown in **Figure 10**. This fluidic approach could scale to 1,000 spatial barcodes per run and eventually microfluidic chips could be used to deliver the beads.

**[00114]** In one embodiment, micronozzle chips (Dolomite) can be used with Fluoridrop emulsion phase (Dolomite) with three syringe pumps under LabScript software control as the core of the Spatial Encoder module **400**. One pump can drive

solutions of beads with oligos, a second pump can drive nuclei suspensions, and a third can drive the emulsion oil. The flow rates can be adjusted using a microscope to produce steady streams of droplets; stirring may be required depending on bead composition. An optical sensor **450** can be incorporated upstream of the micronozzle to trigger changing spatial barcodes.

**[00115]** In one embodiment, single channel fluidics can be used to demonstrate the workflow, *i.e.*, inputting a bolus **308** of nuclei or single cells in a microfluidic flow and encoding the original spatial relationship using four DNA barcodes on oligonucleotides attached to beads (shown conceptually in **Figure 10**). A stream of beads with one spatial code in lysis/RT mix can be added to the bolus of nuclei from a microregion. Monodisperse nanodroplets from single nuclei with spatially coded beads with lysis/RT mix can be produced. As needed, the geometry and flow rates can be altered to adjust bolus size and flow rates with a goal of a Poisson distribution of single cells with each nanodroplet having a bead. Adding different mass tags to single cells or antibodies with DNA barcodes to encode spatial position can be performed to enable additional encoding modalities.

**[00116]** The ability to add two different sets of beads (or initially fluorescent beads) to alternating samples can determine the needed accuracy in timing and volumes and to decide if optical detection of the cell bolus is needed. This can be directly scaled up to two micronozzles for the 24 microsample scale.

**[00117]** The process can be developed with rat liver nuclei to develop the process and then progress to alternating boluses of mouse and rat to detect contamination and inform system cleaning development. After lysis, the RTase reaction can either be performed in nanodroplets, or after breaking droplets: both methods will be tested. The RTase conditions can be optimized with mRNA standard for bulk reactions, and then for nanodroplets. The system can add spatial DNA barcodes or mass tags to existing nanodrop generators. The RTase reaction products can be assayed by qPCR and by processing into libraries with QC steps. External polyadenylated transcripts 250–2,000 nt in length at a  $10^6$  range of concentrations can be used to assess the dynamic range and range of detection with NGS analysis (ERCC RNA Spike in Controls, 4456740, Life Technology). Encapsulation of nuclei with agarose at the formation of nanodroplets will be tested to determine if multiple reactions in a row are possible.

**b. Spatial Encoder.**

**[00118]** The Single Cell Spatial Analysis System Spatial Encoder module **400** inputs the ordered microsamples which may contain single cells or groups of cells from the Spatial Sampler module **300** using the Spatial Sampler output such as an output microchannel as an input to the Spatial Encoder module **400**. The spatial encoder subsystem can place the microsamples in a sequential ordered arrangement in a fluidic stream. This sequential arrangement is referred to as a train, and microsamples in a train are said to be entrained. In a preferred embodiment for nucleic acid encoding, adds beads with known barcodes to correlate with the original spatial information into boluses, creates microdrops, (nanodroplets in some implementations, or boluses in other implementations), preferably with one or less cells per nanodroplet. A bolus **308** is typically elongate in shape, while a nanodroplet is typically spherical. A bolus typically has a volume of at least 3 microliters. A nanodrop typically has a volume of no more than 3 microliters, e.g., about 1.5 microliters. In a preferred embodiment, the Spatial Encoder module **400** outputs single cells or nuclei in nanodroplets or boluses with spatial barcodes on beads.

**[00119]** One embodiment of spatial barcoding is to use beads with oligonucleotides with spatial barcodes **680** is illustrated in **Figure 11**. The beads with oligonucleotides with spatial barcodes **680** can be paramagnetic beads, agarose beads, or others, and have surface chemistry optimized for the nucleic acid capture and subsequent chemistries. The term beads is also used to refer at times to patterning the oligonucleotides with spatial barcodes on a surface rather than on a bead.

**[00120]** Oligonucleotides with spatial barcodes can be generated by synthesis using standard commercially available phosphoramidite or other technology. In one embodiment, the oligonucleotide has a cleavable linker, attached to an amplification primer with fluorescent label, a sequencing primer, barcode region, and capture region. The barcode region is comprised of a spatial barcode, cellular barcode, and molecular barcode.

**[00121]** In one embodiment the spatial barcode can be 5 nucleotides long to provide 1,024 barcodes for spatial resolution. Cellular barcodes can be 6 nucleotides, or other lengths, and synthesized by split-pool synthesis, and molecular barcode can be 8 nucleotides synthesized by degenerate synthesis; the cellular barcodes only need to identify cells from within a single microsample since each microsample is encoded with

a spatial barcode. In a preferred embodiment, each spatial barcode is unique for each set of microsamples that are analyzed together. In other embodiments, spatial barcodes can be shared between microsamples and then resolved bioinformatically using cellular barcode to sort and cluster by cells to resolve spatial barcode ambiguities. Spatial, cellular, and molecular barcodes can be of different lengths or in different orders, or dispersed among other elements of the oligonucleotide with spatial barcode 50 without limitation.

**[00122]** The oligonucleotides, such as amino-modified oligonucleotides, can be initially attached to commercially available paramagnetic beads by covalent crosslinking and may include a cleavable linker bond (Ju. J. *et. al.* United States Patent 9,133,511. September 15, 2015.), (Knapp D.C. *et. al.* Bioconjug Chem. 2010; 21(6):1043-55.), ([https://www.clickchemistrytools.com/products/click\\_chemistry\\_toolbox](https://www.clickchemistrytools.com/products/click_chemistry_toolbox)), (Olejnik J. *et. al.* Nucleic Acids Res. 1996;24(2):361-6.). Fluorescent probes can be attached to the oligonucleotide distal from the bead and cleavable bond or alternatively fluorescent nucleic acid base analogs can be used such as 2-Aminopurine (Wilhelmsson, Quarterley Reviews of Biophysics, 43, 2, 2010, 159-183). The cleavage of labeled oligonucleotides can be used for assay development since the oligonucleotide can be analyzed by fragment sizing on CE with the fluorescent tag to give the distribution of sizes to assess library quality.

**[00123]** The hardware and software of the Spatial Encoder module **300** must deliver a set of beads with a unique, known, spatial barcode to each microsample. Referring to **Figure 10**, the Spatial Encoding fluidic delivery can use a spatial barcode reagent rail **401** to access beads each with a single spatial barcode, controlled by spatial barcode reagent rail valves respectively, to deliver reagents through by spatial barcode fluidic channel to spatial barcode syringe pump **412**. It is within the scope that the spatially barcoded beads will scale to 1,024 or greater number of spatial barcodes per run for the Single Cell Spatial Analysis System.

**[00124]** As microsamples **370** are moved from Spatial Sampler output, such as a microchannel, reagent rail syringe pump **412** and spatial barcode reagent rail **401** can select a reagent of singly spatially barcoded beads, such as beads all with a single spatial barcode, but with unique cellular barcodes and UMIs, and delivers a bolus of beads through spatial barcode connecting channel to spatial encoder junction to merge with the microsample **370** in spatial encoder cartridge **4400**. Optical, conductance, or

other sensors can be incorporated as needed to detect the microsample **370** in the bolus and coordinate the addition of the spatially barcoded beads to the bolus.

**[00125]** The bolus then passes through a spatial encoder microchannel to nozzle **429** where an immiscible fluid such as FluorInert, Droplet Generation Oil (Biorad, #1863005), or other solutions can be added by nanodroplet generation syringe pumps to the bolus to produce nanodroplets, preferably 1.5 nL, and sent down spatial encoder output microchannel as output from the Spatial Encoder. Nanodroplet generation syringe pumps can also be combined into one syringe pump that has two microchannels that split in two from nanodroplet generation syringe pump output to join the microsample **370** with barcoded bead bolus from either side to produce nanodroplets, eliminating the need for a second nanodroplet generation syringe pump. Nozzle designs and circuits are incorporated by reference (Macosko E.Z. *et. al.* Cell. 2015;161(5):1202-14.) (Klein A. M. *et. al.* Cell. 2015;161(5):1187-201.) (Geng T. *et. al.* Anal Chem. 2014;86(1):703-12).

**[00126]** In an alternative embodiment, the microsample bolus with the added spatially barcoded beads are processed as a bolus without the formation of nanodroplets. In this approach, the bolus may be preferably less than 5 nL, or 10 nL, or 25 nL, or 100 nL, or 250 nL, and 10,000 microsamples may be less than 2.5 mL.

**[00127]** In one embodiment, single channel fluidics are used. For example, 100 nL of beads with one spatial code are added in junction to the, for example, 100 nL of microsample in output microchannel and lysis and/or reaction mixtures, such as lysis/reverse transcriptase mix, added separately through spatial encoder reagent syringe pump and reagent connecting microchannel.

**[00128]** Monodispersed nanodroplets from single cells with spatially coded beads with lysis and/or reaction mixtures, *e.g.*, lysis/RT mix for RNA-Seq, lysis/restriction mix for DNA sequencing, are then be produced using a nozzle **429** (Macosko E.Z. *et. al.* Cell. 2015;161(5):1202-14.) (Klein A. M. *et. al.* Cell. 2015;161(5):1187-201.) (Geng T. *et. al.* Anal Chem. 2014;86(1):703-12.) and output through spatial encoder output microchannel **430**. As needed, the geometry and flow rates can be altered to adjust size and flow rates to produce a Poisson distribution of single cells with each nanodroplet preferably having a spatially barcoded bead.

**[00129]** In other embodiments, the bolus from the Spatial Sampler module **300** is physically separated by structures, volumes, or surfaces, for example, by placing the bolus into a microtiter or smaller well or tube. The Spatial Sampler module **300** output

can be used to be physically dispersed onto the surface of a material comprised of agar, membranes, arrays of beads, microscope slides, flow cells, and others. The physical dispersion can be by moving the surface under a capillary or other flow, by printing with a microarray pen, by piezospraying, electrowetting, microfluidics, or other methods.

The physically separated microsample bolus can be dispersed such that, for example on the surface of agar, all cells are far enough apart to be processed as single cells.

**[00130]** In one embodiment, a spatial encoder reagent syringe pump adds a low melting temperature agarose to encapsulate the nanodroplet with heated liquified agarose (Geng T. *et. al.* Anal Chem. 2014;86(1):703-12.) during the formation of nanodroplets. Once cooled, the agarose can be used as a barrier permeable to low molecular weight components, such as reaction components, but not to high molecular weight components such as nucleic acids when it is cooled. The use of agarose to encapsulate the reactions enables multiple sequential reactions or manipulations in a row to be performed in the nanodroplet **325** with reactants diffusing into the agarose encapsulated nanodroplet.

**[00131] Example 1: Nanowell processing spatial encoding of microregions from frozen tissue.**

**[00132]** In an alternative approach the Spatial Sampler module **300** can output nuclei into spatially barcoded nanowells **319** as illustrated in Figure 7 or beads with the spatial barcodes can be added to an array of nanowells **320** that does not have spatial barcodes attached to the nanowells.

**[00133]** The specimen **301** can be held in the same carrier for processing but in this approach the output from the capillaries is directly to nanowells. The nanowells **308** on the bottom of the 24 or 96 reservoirs can be of the order of 30 micron diameter to only accept one nucleus and oligonucleotide primers with poly-T, and spatial, cellular, and UMI barcodes and amplification primers attached to the walls of the wells. Devices for the nanowell **308** approach can be prototyped using 3D printing, embossing, and glass etching. The nanowells **308** can also be coated with anti-nuclear antigens, *e.g.*, *NeuN*, for capture of neuronal nuclei. The nanowells **308** can replace the downstream nanodrop generation and potentially simplify the system as well being adaptable to more assays than nanodrops.

**[00134] Example 2: Systems integration of a low throughput Spatial Sequencer to process solid tissue in spatial single nuclei, ready for downstream sequencing.**

**[00135]** A low throughput platform is described that integrates the Spatial Sampler **300** and Spatial Encoder **400** workflows together and with the downstream NGS workflows. As individual components, workflows, and modules are developed they can be manually integrated and then automated using LabScript software for instrument and component control using electronics and firmware for the single-cell sequencing infrastructure.

**[00136]** The integrated workflow can developed first on the bench with can cells or nuclei from fresh or flash frozen rodent tissue. Nuclei produced from the Singulator prototype will be processed into single nuclei or bulk libraries on a micronozzle (Dolomite) at a range from 10 to 1,000,000 nuclei. The nuclei can be assessed by qPCR and the libraries will by qPCR (Kapa, Library Quant Kit for Illumina Sequencing Platforms) and by length distribution (Bioanalyzer). As appropriate, the libraries can be sequenced and the single nuclei compared with bulk representation. Microregions **308** can be tested for sensitivity and cellular representation to determine system workflow options. The amount of nuclei purification required can be tested with NGS and strategies to improve performance, such as pulldown of nuclei or tangential flow filtration can be employed.

**[00137]** The workflow can be developed on the system as each module is brought up. First single microregions **308** from rat liver can be processed and integrated to a single micronozzle **429** and standard beads. The requirements to pool samples can be tested. As described above the system can scale from 1 to 12 to 96 or more.

**[00138]** The downstream NGS workflow can use single-nuclei sequencing for NGS sequencing with a RNA-Seq computational pipeline to assess the quality of the data and, optionally, the reads trimmed and those with poor quality filtered out. High quality reads can aligned to reference genomes or transcriptomes using one of the many available high-throughput sequencing mapping tools. Alignments can be assembled into full-length transcripts based on a reference genome and subsequently passed to quantification tools to obtain a measure of expression. After completing these main steps, several differential analyses can be executed to identify differentially expressed genes and transcripts.

**[00139] Example 3: A high throughput spatial system with imaging and additional applications to process frozen tissue sections to spatially analyzed data.**

**[00140]** The Spatial Sequencer **100** can be scaled up to provide multiplexed, high-throughput, high resolution mapping of human tissues, integrated imaging, and multiple 'omic applications. The platform can be designed to be extensible for many biomolecules. Multiple additional human tissues can be mapped at the single cell resolution to provide an invaluable tool to understand cellular microenvironments and tissue organization.

**[00141]** In one embodiment, the Spatial Sequencer **100** can be a high throughput system that can image the section, optionally apply contrast agents, and repeatedly sample a larger format tissue sections to rapidly generate spatially encoded samples for multiple genomic and proteomic assays. Building on the basic design of the low throughput system, the number of microregions processed can be scaled from 24 to 96 or 384 and the micronozzles increased to 8 with increased multiplexing. The ability to map multiple auto-feed sections as a 3D representation can be added.

**[00142] Example 4: Development of optics and hardware capabilities.**

**[00143]** Imaging tissue section is critical to determine pathology and direct analytical efforts to regions of interest. A high-resolution imaging station can be added or integrated with and potentially lower resolution imaging incorporated on the multifunctional head. The capability to deposit fluids such as contrast agents onto the tissue section can be added with multiple piezoelectric nozzles receiving different solutions.

**[00144]** To integrate an imaging station or capability, commercial products can be used to scan at cellular resolution such as a modularly constructed imager which permits choice of blue, green or near IR optical heads and cellular resolution as a possible station and the information from the scan used to identify regions of interest.

**[00145]** In an alternate embodiment, an epifluorescent imager can be designed with illumination by a green or red laser diode through a beam-splitter with detection by a >10 megapixel CCD/CMOS detector after blocking the laser line and focusing. The optical can will be developed and refined in a ray tracing program for commercially available lenses and filters in a glue-up fixture. The components can installed and aligned on an optical bench, and the response of the camera (or COTS device) to different levels of illumination characterized. The output of the imaging device can be processed in LabScript or other software to quantify total number of cells and non-viable cells. Camera control and image acquisition can be based on Point Grey/FLIR Spinnaker SDK optimized for machine vision applications or other libraries for spectral

analysis and cellular analysis. Examples of image processing using Image J freeware, Cell Profiler, or other software can be compared for parameters known to impact cell recognition.

**[00146] Example 5: Spatial proteomic applications.**

**[00147]** The Spatial Sequencer **100** platform can enable multiple proteomic assays. Mass tags or other metabolomic or proteomic labels can be added at multiple points in the workflow: in the Spatial Sampler module **300** or in the spatial encoder module **400** instead of by a bead or by a nanowell. A bottom array portion of the cartridge can have unique mass tags that are solubilized as nuclei or single cells are liberated. The mass tags can then either be entrained with the bolus or are deposited with the bolus into nanowell plates. Upon analysis, the MS readout of the mass tags decode the microregion where the nuclei or the released cellular cytoplasm originated.

**[00148]** In many applications, antibodies are labeled with DNA barcodes to measure antibody-epitope interactions, now by NGS. If the antibodies are to specific nucleus membrane components (or for cells to cell surface epitopes), have spatial barcodes attached, and are mixed in upon cellular lysis, only nuclei or cells with the epitopes will be captured. The nuclei or cells can be washed and then lysed and the spatial barcodes readout by NGS to quantify binding by specific cell types for example.

**[00149] Example 6: spatial single nucleus chromatin accessibility assay.**

**[00150]** In the ATAC-Seq application, a Tn5 transposon with sequencing adapters 'hops' into regions of the chromosome that are opened up to address regulatory variation. In one embodiment, the Tn5 transposon is modified to have spatial barcodes and the polyT beads replaced with Tn5 transposons with spatial addresses. The protocol can also be readily adapted to the nanowells embodiment with pooling after the hop. ATAC-Seq from bulk measurements can be compared with aggregating ssnATAC-Seq.

**[00151] Example 7: Spatial single nuclei DNA sequencing.**

**[00152]** The Spatial Sequencer **100** enables multiple approaches to be tested for spatial single nuclei DNA sequencing. In one embodiment microregions **304** are collected in nanowells, with Phi 29 amplification of the DNA, and the workflow done conventionally after directing the microregions **304** into individual reactors with different spatial barcodes.

**[00153]** In another embodiment, low melting point agarose is employed as a heated liquid to encapsulate single nuclei so that low molecule weight reactants, such as

nucleotides and enzymes, can be exchanged through the gel surrounding the nanodroplets **325** after cooling. Nuclei can be passed through the micronozzle with low melting point agarose with biochemicals to form 'nuclei beads' in an emulsion with spatial oligos complementary to targeted sequence of interest. The beads can be treated in multi-steps off the instrument to perform multiple reactions in a row, much like nanoreactors. The beads can re-form on chilling, can be collected and the next reaction added. In one embodiment, a dsDNA Fragmentase® (NEB) step can be performed followed by heating and then snap chilling to form single stranded regions. The DNA can be hybridized with the spatially barcoded targets and, after reagent change through the gel bead, PCR amplified in the nanoreactors with the appropriate primers.

**[00154] Example 8: Spatial methylation application.**

**[00155]** Both the nanowell approach and the low melting point agarose with nanodroplets **325** can be used to determine the methylome. For low melting point agarose with beads, the approach would be to isolate the single nuclei in nanodroplets **325** containing beads with targeted oligos with spatial codes, lyse, and collect the beads. The beads are treated with bisulfite. Beads are chilled and collected, and after reagent change through the solidified agarose surrounding the nanodroplet with bead, the PCR amplified in the nanoreactors with the appropriate tagged primers.

**[00156] Example 9: Tissue expansion for spatial sequencing.**

**[00157]** The expansion technology of Boyden can allow conversion of frozen tissue by four-fold, and reducing the number of nuclei in the microregion. Experiments can be performed to see if frozen tissue can be expanded and if so if nuclei can be released. This can allow one size or array head to collect both microregions with 10s of nuclei and single nuclei by using expansion.

**[00158] Example 10: Spatial sampling using microsyringes**

**[00159]** In another embodiment, the spatial sampling to collect microregions is done using a microsyringe instead of the sampling head. In this embodiment, a microsyringe, e.g., Hamilton microsyringes, (1.2 µl, 203185), is controlled by a robotic device to deliver nuclei isolation solution **920** to a microregion **304** on the specimen **301** or cryosection **303**, and then to as needed pipette the fluid back and forth over the microregion **304** and then pull the solution from disrupted tissue, now containing nuclei or single cells, into the microsyringe. The microsyringe can be moved by the robotics to the appropriate destination for the next processing steps.

**[00160]** In some embodiments the microregion is moved to a nanowell **319** and processed. In other embodiments the microregion **304** in the micropipette is moved to a Spatial Encoder module **400** and deposited into a reservoir that is then used to create nanodroplets **325** for spatial encoding into the nucleic acid. In some embodiments, the microsyringe can contain the spatial barcodes attached to the microsyringe barrel or plunger, or on beads preloaded, or beads can be picked up for each barcode from a storage container, e.g., a microtiter plate, Eppendorf tube, or other device, and then delivered to a nanodroplet generator.

**[00161] Example 11: Integrated spatial sampler and spatial encoder cartridge.**

**[00162]** In one embodiment, illustrated in **Figure 12**, the spatial sampler cartridge **4300** and the spatial encoder cartridge **4400** are combined into a single integrated cartridge **4500**. Integrated cartridge **4500** can process single cells or nuclei from specimen **301** after receiving dissociated single cells or nuclei through mesh **250** into lower array of conduits **307** and to FROLC connector **316** to produce single cells or nuclei entrained as a series of boluses **308**. Optional sample preparation processor **321** purifies the single cells or nuclei by functionalities such as acoustic focusing, tangential flow filtration, hydrodynamic flow, electrowetting, electric focusing, bead purification, flow cytometry, or other modalities that do not interfere with the order of the boluses; fluidic connection **322** is connected by line **323** to add reagents to sample preparation processor **321**. Optional optical interrogation area **450** can have features to reflect, focus, or filter light. In a preferred embodiment nozzle **429** joins channel **462** to fluidic connection **461** which can connect to a spatial barcode reagent rail **401** to add spatially encoded beads. In another embodiment, a nozzle is not used, and the boluses **308** entrained in order have spatial barcode reagent with lysis and reverse transcription added to metagenomics of a microregion **304** or the bolus **308** can have solutions with high viscosities, such as polyethylene glycol or low melt agarose added to slow diffusion between regions of the bolus **308** during the reverse transcription.

**[00163]** In one embodiment, after generation of nanodroplets (which do not touch the side of the conduit) from boluses **308**, the nanodroplets **325** can be processed on the cartridge **4500** in reaction chamber **440**. Reaction chamber **440** is connected to channel **464** to fluidic connection **463** which can connect to reagents on the instrument, or the reagents can be placed on cartridge **4500**. In a preferred embodiment, the temperature of reaction chamber **440** can be adjusted by the instrument to a range from under 4°C to over 95°C to perform reactions such as reverse transcription to incorporate

the spatial barcodes. In one embodiment, reverse transcription is performed in reaction chamber **440** at 37°C.

**[00164]** In some embodiments, when magnetic beads are used, magnetic fields can be applied by the instrument to reaction chamber **440** to perform a series of reactions after reverse transcription such as end polishing followed by ligation and size selection for library preparation. In some embodiments, the temperature of reaction chamber **440** can be thermal cycle to amplify fragments by polymerase chain reaction. In one embodiment, the reaction is monitored in real time to control the amplification.

**[00165]** In another embodiment, after reverse transcription, the nanodroplets **325** can be broken and the transposon from the Nextera Flex Library Preparation (Illumina) kits can be added to generate libraries. Other biochemical manipulations such as ATAC-Seq, methylation, etc. can be performed in reaction chamber **440**. Following optional reactions in reaction chamber **440**, the spatially encoded material can be output through spatial encoder output microchannel **430** for additional sample preparation, quality control, or analysis.

**[00166]** Integrated cartridge **4500** can be injection molded with microchannels sealed with a transparent layer by laminating an optical heat seal (ThermoFisher, Catalog number HSF0031), or other material, by ultra sonic welding, glues, adhesives, or other well known means.

**[00167]** As used herein, the following meanings apply unless otherwise specified. As used herein, the following meanings apply unless otherwise specified. The word “may” is used in a permissive sense (i.e., meaning having the potential to), rather than the mandatory sense (i.e., meaning must). The words “include”, “including”, and “includes” and the like mean including, but not limited to. The singular forms “a,” “an,” and “the” include plural referents. Thus, for example, reference to “an element” includes a combination of two or more elements, notwithstanding use of other terms and phrases for one or more elements, such as “one or more.” As used herein, the terms “comprises,” “comprising,” “includes,” “including,” “has,” “having” or any other variation thereof, are intended to cover a non-exclusive inclusion. For example, a process, method, article, or apparatus that comprises a list of features is not necessarily limited only to those features but may include other features not expressly listed or inherent to such process, method, article, or apparatus. The term “or” is, unless indicated otherwise, non-exclusive, i.e., encompassing both “and” and “or.” Further, unless expressly stated to the contrary, “or” refers to an inclusive-or and not to an exclusive-or.

For example, a condition A or B is satisfied by any one of the following: A is true (or present) and B is false (or not present), A is false (or not present) and B is true (or present), and both A and B are true (or present). Both plural and singular means may be included. The term "any of" between a modifier and a sequence means that the modifier modifies each member of the sequence. So, for example, the phrase "at least any of 1, 2 or 3" means "at least 1, at least 2 or at least 3". The term "consisting essentially of" refers to the inclusion of recited elements and other elements that do not materially affect the basic and novel characteristics of a claimed combination.

**[00168]** It will be readily apparent to one of ordinary skill in the art that the embodiments and implementations are not necessarily inclusive or exclusive of each other and may be combined in any manner that is non-conflicting and otherwise possible, whether they be presented in association with a same, or a different, embodiment or implementation. The description of one embodiment or implementation is not intended to be limiting with respect to other embodiments and/or implementations. Also, any one or more function, step, operation, or technique described elsewhere in this specification may, in alternative implementations, be combined with any one or more function, step, operation, or technique described in the summary. Thus, the above embodiment and implementations are illustrative rather than limiting.

**[00169]** All patents, patent applications, published applications, treatises and other publications referred to herein, both supra and infra, are incorporated by reference in their entirety. If a definition and/or description is set forth herein that is contrary to or otherwise inconsistent with any definition set forth in the patents, patent applications, published applications, and other publications that are herein incorporated by reference, the definition and/or description set forth herein prevails over the definition that is incorporated by reference.

**What is Claimed Is:**

1. A system comprising:
  - a) spatial sampler system configured to collect and transmit one or a plurality of cells or nuclei from a tissue specimen, the system comprising:
    - i) a lower carrier having an array of conduits passing therethrough, each conduit comprising an opening on a first side of the lower carrier and communicating with an opening on a second side, wherein the opening on the second side of the lower carrier either (1) terminates in a capillary or (2) opens onto a well of a multiwell plate;
    - ii) positioned, above the lower carrier, a perforated specimen holder configured to support a frozen tissue specimen, wherein the specimen holder comprises a plurality of perforations having a size sufficient to permit the passage of cells or nuclei; and
    - iii) positioned, above the specimen holder, a multifunctional head comprising an upper array of upper conduits, optionally, each aligned with a conduit opening of the lower carrier.
2. The system of claim 1, wherein the openings on the top side of the lower carrier are configured as wells that communicate with narrower conduits.
3. The system of claim 1, wherein the openings on the top side of the lower carrier have a diameter of about 2  $\mu\text{m}$  to about 150  $\mu\text{m}$  e.g., about 100 microns.
4. The system of claim 1, wherein the conduits are selected from capillaries, microchannels, tubing, and electrowetting conduits.
5. The system of claim 1, wherein a plurality of the conduits each have different lengths, wherein the lengths are determined based on relative spatial position of the conduits in the array.
6. The system of claim 1, wherein the lower conduits communicate with a common fluid conduit.
7. The system of claim 1, wherein the lower conduits are mated with nozzles leading to a common conduit.
8. The system of claim 1, wherein the lower conduits each communicate with a different well or set of wells of a multiwell plate.

- 9.** The system of claim **1**, wherein the specimen holder comprises a mesh, e.g., a stainless-steel mesh, polymer mesh, metal mesh, strainer, or filter.
- 10.** The system of claim **1**, wherein the perforations have a diameter of about 20  $\mu\text{m}$  to about 100  $\mu\text{m}$ , e.g., about 20  $\mu\text{m}$  to about 50  $\mu\text{m}$  or about 50  $\mu\text{m}$  to about 100  $\mu\text{m}$ , e.g. about 30 microns.
- 11.** The system of claim **1**, further comprising a cryopreserved tissue specimen in the specimen holder.
- 12.** The system of claim **1**, wherein the multifunctional head has an array of between 12 and 96 conduits.
- 13.** The system of claim **1**, wherein the upper array of conduits is ganged fluidically to a syringe pump configured to deliver one or more solutions (nuclei isolation solution, tissue disruption solution to produce single cells, emulsion oil, or cleaning solution) to a microregion on the specimen carrier.
- 14.** The system of claim **1**, wherein the system comprises a container of a tissue disruption solution comprising one or more collagenases and/or one or more proteinases and/or a nuclei isolation solution comprising a chemical that disrupts cell membranes, e.g., comprising a detergent.
- 15.** The system of claim **1**, comprising a temperature controller to control temperature of the specimen holder.
- 16.** The system of claim **15**, wherein the temperature controller comprises a Peltier.
- 17.** The system of claim **1**, wherein the multifunctional head comprises at least any of 1, 12, 24, 96, 384 conduits.
- 18.** The system of claim **1**, wherein the multifunctional head is configured to deliver nuclei isolation solution through the conduits to a tissue specimen positioned on the specimen support.
- 19.** The system of claim **1**, wherein the multifunctional head is configured to deliver pressure and/or vacuum to the conduits.
- 20.** The system of claim **1**, further comprising a movable arm operatively attached to a motor and controlled by a computer (e.g., a robot) that moves the multifunctional head along any dimension of a three-dimensional axis.

**21.** The system of claim **1**, further comprising a motor that moves the multifunctional head along a direction substantially perpendicular to a plane of the specimen carrier, *e.g.*, so as to sandwich a specimen held by the sample carrier between the lower carrier and conduits in the multifunctional head.

**22.** The system of claim **1**, further comprising a computer comprising a processor and memory including code that, when executed by the processor, controls the movement of the multifunctional head and the delivery of pressure or vacuum through the upper conduits.

**23.** The system of claim **1**, further comprising a motor that moves the sample carrier in an X-Y plane parallel to a face of the multifunctional head.

**24.** The system of claim **1**, wherein the multifunctional head comprises an imaging station configured to image a specimen on the sample carrier.

**25.** The system of claim **1**, wherein the multifunctional head further comprises a dispense head configured to dispense liquids, *e.g.*, imaging reagents or dissociation or other solutions, onto the biological specimen.

**26.** The system of claim **25**, wherein the transfer head comprises a plurality of extraction channels where in the extraction channels are arrayed in a two dimensional array (*e.g.*, a line) or a three-dimensional array (*e.g.*, a plane).

**27.** The system of claim **26**, wherein the spatial encoder subsystem comprises a plurality of fluidic channels that merge into the encoder channel in which each has an inlet configured to receive the microsamples from an extraction channel.

**28.** The system of claim **27**, wherein, the transfer membranes have attached thereto a plurality of capture elements, each capture element comprising a particle, which is optionally paramagnetic, having attached thereto one or more antibodies that bind cells in the biological specimen, and nucleic acid markers comprising positional barcodes comprising spatial information where the spatial information identifies the position of the particle on the transfer membranes on the multifunctional head.

**29.** The system of claim **28**, wherein, the nucleic acid markers further comprise cell markers identifying the cell to which particle binds, and/or molecular barcodes that differently label different nucleic acid molecules and a single cell.

**30.** The system of claim **28**, wherein the nucleic acid markers further comprise cell markers identifying the cell to which particle binds, and/or molecular barcodes that differently label different nucleic acid molecules and a single cell, and the particle comprises a capture sequence such as polyT with a spatial barcode.

**31.** The system of claim **1**, further comprising:

b) a spatial encoder subsystem configured to perform a series of biochemical reactions on an emulsion comprising microdrops produced by the spatial sampler system, wherein the spatial encoder subsystem comprises:

i) a reaction device comprising an inlet configured to receive microdrops from the spatial sampler subsystem, at least one reaction chamber, and an outlet;

ii) a reagent rail communicating with the reaction device through a microchannel and comprising reagent sufficient to perform at least one of biochemical reaction on analytes in the microdrops;

iii) one or more pumps configured to move the reagents from the reagent rail through the microchannel to the reaction chamber of the reaction device; and

iv) optionally, one or more detectors to sense bolus or fluids to control merging of reagents and specimen.

**32.** The system of claim **31**, wherein the spatial sampler subsystem and the spatial encoder system are configured as fluidically communicating modules in the system.

**33.** The system of claim **31**, wherein the spatial encoder subsystem further comprising:

v) a temperature controller configured to control temperature in the reaction chamber.

**34.** The system of claim **31**, wherein the spatial encoder system further comprising:

v) a magnet configured to reversibly immobilize paramagnetic particles contained in the reaction chamber.

**35.** The system of claim **31**, wherein the biochemical reactions comprise reverse transcription of messenger RNA into cDNA encoding the spatial information.

**36.** The system of claim **31**, wherein the biochemical reactions comprise at least:

- (i) reverse transcription of messenger RNA into cDNA; and
- (ii) amplification of cDNA.

**37.** The spatial analysis system of claim **31**, wherein the biochemical reactions comprise at least:

- (i) primer extension of a primer hybridized to a DNA template to create an extension product; and
- (ii) amplification of the extension product.

**38.** A method comprising:

- a) providing a frozen biological tissue specimen on a sample carrier, wherein cells in the tissue sample have a spatial position in the tissue specimen, and wherein the sample carrier comprises (i) a perforated support that supports the tissue specimen and (ii) an array of passages at addressable positions through the sample carrier and positioned below the perforated support;
- b) disrupting cells in the tissue specimen to release one or a plurality of cells or nuclei; and
- c) collecting a microsample comprising one or a plurality of released cells or nuclei through the perforations into the passages, wherein the addressable position of a passage indicates the original spatial position of the cell or nuclei moved into the passage.

**39.** The method of claim **38**, wherein collecting comprises moving cells or nuclei by force, *e.g.*, by pressure, exerted by a liquid, into the passages.

**40.** The method of claim **38**, comprising collecting cells or nuclei from at least one, a plurality, at least 96 or at least 384 different microregions in the tissue specimen.

**41.** The method of claim **38**, wherein single cells or nuclei are collected per passage.

**42.** The method of claim **38**, wherein single cells or nuclei are collected into passages from a microregion in the tissue specimen having a largest dimension of about 20 microns to about 150 microns.

**43.** The method of claim **38**, further comprising determining biomolecular information (e.g., proteomic information, nucleic acid sequence information, epigenetic (e.g., methylation pattern, chromatin accessibility, proximal DNA interactions, *etc.*) from the nuclei collected in each passage.

**44.** The method of claim **38**, further comprising creating a 2-D or 3-D map of the tissue specimen indicating spatial position of biomolecular information (e.g., proteomic information, nucleic acid sequence information, epigenetic) of the tissue.

**45.** The method of claim **38**, further comprising:  
sectioning a frozen tissue specimen into a plurality of slices;  
processing each slice according to operation (a) through (c);  
generating biomolecules from one or more microregions of each slice; and  
producing a 3-D reconstruction of spatial position of the information in the original tissue specimen.

**46.** The method of claim **38**, further comprising encoding biomolecules collected from each spatial position with positional information tags that indicate the original spatial position of the biomolecules in the tissue specimen.

**47.** The method of claim **46**, wherein the information tag is a barcoded antibody, a barcoded oligonucleotide or a mass tag.

**48.** The method of claim **38**, wherein disrupting tissue into cells or nuclei comprises delivering to the tissue specimen on the platform a nuclei isolation solution (*i.e.*, a solution that disrupts cell membranes, e.g., comprising a detergent) or a tissue disruption solution that produces single cells.

**49.** The method of claim **48**, wherein the solution is delivered through an array of capillaries positioned above the specimen carrier.

**50.** The method of claim **48**, wherein the solution is delivered to each of a plurality of microregions, and single cells or nuclei are collected from the microregion, in sequence.

**51.** The method of claim **38**, wherein disrupting cells comprises physical disruption.

**52.** The method of claim **38**, further comprising delivering collected single cells or nuclei in boluses into a single flow stream, wherein a position of a bolus in a

train of boluses in the flow stream depends on the original spatial position of the single cells or nuclei in the bolus in the tissue specimen.

**53.** The method of claim **38**, comprising collecting a single cell nucleus from each microregion.

**54.** The method of claim **38**, further comprising:

d) delivering collected cells or nuclei into wells of a multi-well plate, wherein the position of the wells into which cells or nuclei are delivered depends on the original spatial position of the cells or nuclei in the bolus in the tissue specimen.

**55.** The method of claim **38**, further comprising:

d) contacting a collected microsample with a solid particle (e.g., a bead) having attached thereto an oligonucleotide comprising an amplification primer and oligonucleotide barcode sequence, wherein the barcode sequence provides information about the original spatial position of the cells or nuclei in the microsample in the tissue specimen.

**56.** The method of claim **38**, further comprising:

d) contacting a collected microsample with a transposon comprising spatial barcodes, which spatial barcodes provide information about the original spatial position of the cells or nuclei in the microsample in the tissue specimen.

**57.** The method of claim **38**, further comprising:

d) encapsulating single collected cells or nuclei in low melting point gel beads.

**58.** The method of claim **38**, further comprising:

d) treating collected nucleic acids in the cells or nuclei with bisulfite and determining methylation patterns of the bisulfite-treated DNA.

**59.** A method comprising using the system of claim **1** to entrain in a fluidic stream a plurality of microsamples from a biological specimen, wherein the microsamples are contained in spatially separated microdrops or boluses in the fluidic stream and positioned in an order based on their original spatial position within the biological specimen.

**60.** The method of claim **59**, comprising:

a) providing a biological specimen;

- b) collecting microsamples from one or each of a plurality of different spatial positions in the biological specimen;
- c) introducing the microsamples in a predetermined order into a fluidic stream in a fluidic channel;
- d) dividing the fluidic stream into microdrops by introducing boluses of immiscible liquid into the fluidic channel, whereby the microsamples are incorporated into microdrops that are spatially separated from each other in the fluidic stream.

**61.** The method of claim **60**, further comprising:

- (i) introducing into the fluidic stream a plurality of different spatial markers encoding spatial information, wherein the different spatial markers are incorporated into different microdrops in the fluidic stream, thereby encoding each microdrop with spatial information.

**62.** An article comprising a carrier or cartridge comprising an array of nanowells, each nanowell comprising an oligonucleotide barcode encoding relative position of the nanowell in the array, wherein the oligonucleotide is attached to a wall of the nanowell or to a solid particle comprised in the nanowell.

**63.** The article of claim **62**, wherein each nanowell is configured to hold no more than any of 1, 2, 3, 4, 5, 6, 7, 8, 9 or 10 individual nuclei or no more than any of 1, 2, 3, 4, 5, 6, 7, 8, 9 or 10 individual cells.

**64.** The article of claim **62**, wherein the carrier comprises an array of at least any of 500, 1000, 1500, 2000 or 2500 nanowells.

**65.** A method comprising:

- a) providing a frozen tissue specimen on a support mesh;
- b) freeing one or a plurality of cells or nuclei from cells in the tissue specimen while maintaining their spatial relationship;
- c) moving the freed nuclei into a train or solid support whereby their spatial information is maintained.

**66.** A method comprising:

- a) providing a frozen biological tissue specimen on a sample carrier, wherein cells in the tissue specimen have a spatial position in the tissue specimen;
- b) delivering, with a microsyringe, tissue disruption solution and or nuclei isolation solution to a microregion of the tissue specimen to release one or a plurality of cells or nuclei;

c) collecting, with a microsyringe, a microsample comprising one or a plurality of released cells or nuclei; and

d) moving the microsyringe with the microsample to a well of multiwell plate or to a spatial encoder module and delivering the cells or nuclei in the microsample.

**67.** The method of claim **66**, wherein the microsyringe is controlled by a robotic device.

**68.** The method of claim **66**, wherein the microsyringe contains spatial barcodes attached to a microsyringe barrel or plunger, or on beads preloaded into the microsyringe or picked up after collection of the microsample and then delivered to a nanodroplet generator.

Figure 1

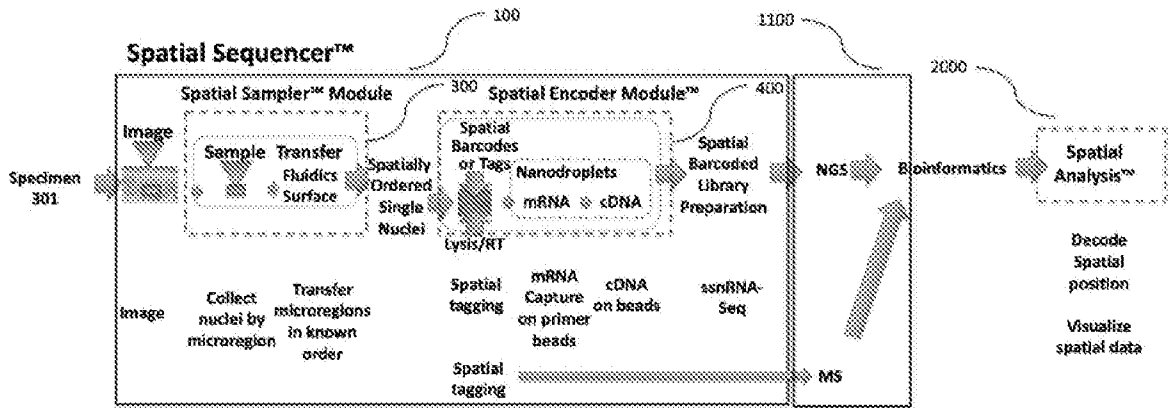
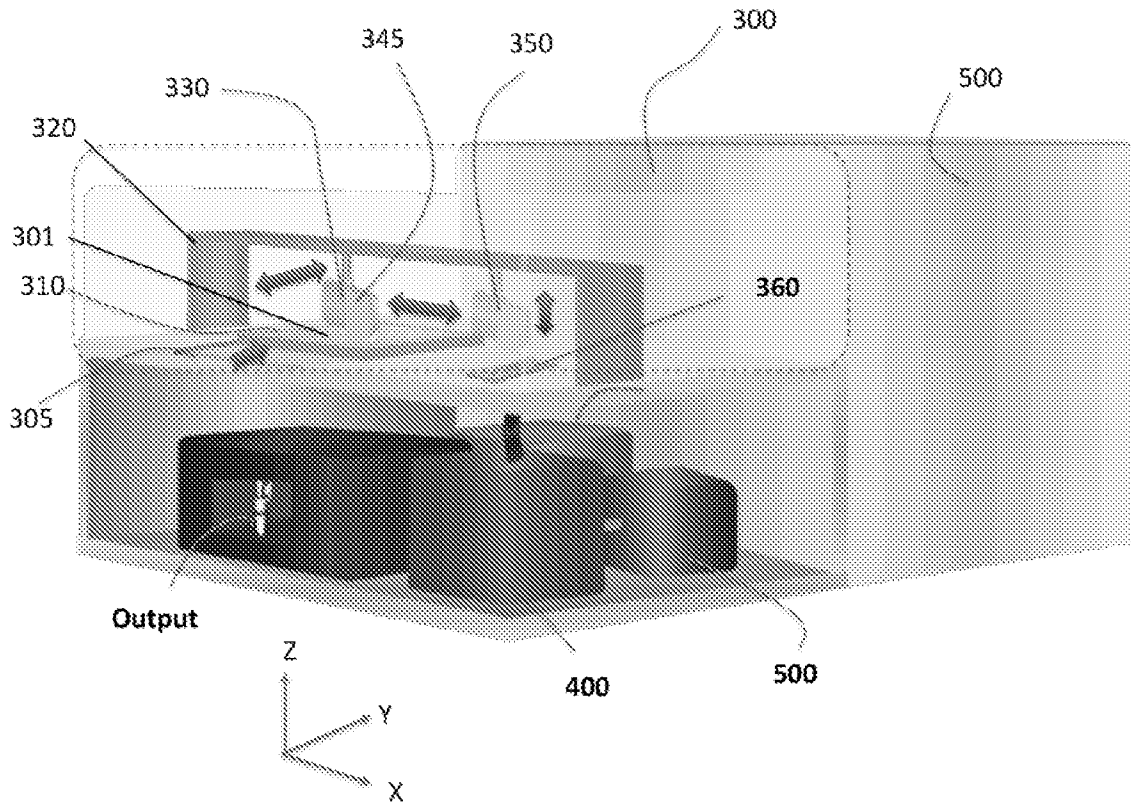

Figure 2



**Figure 3**

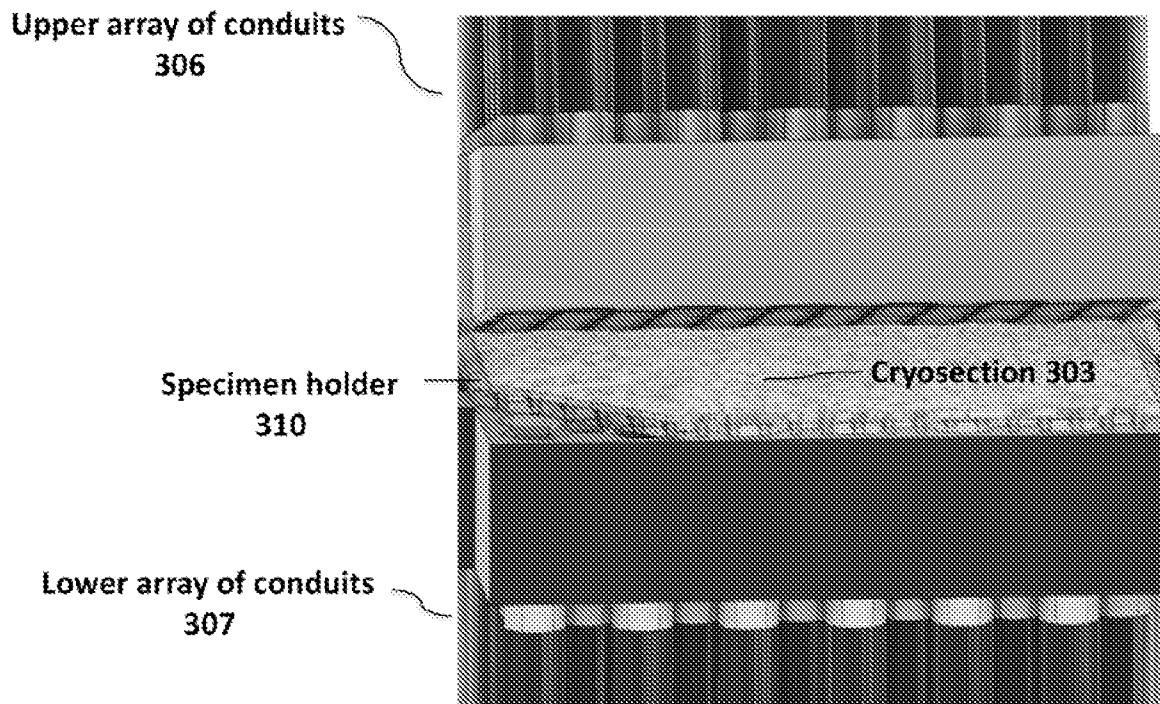

Figure 4

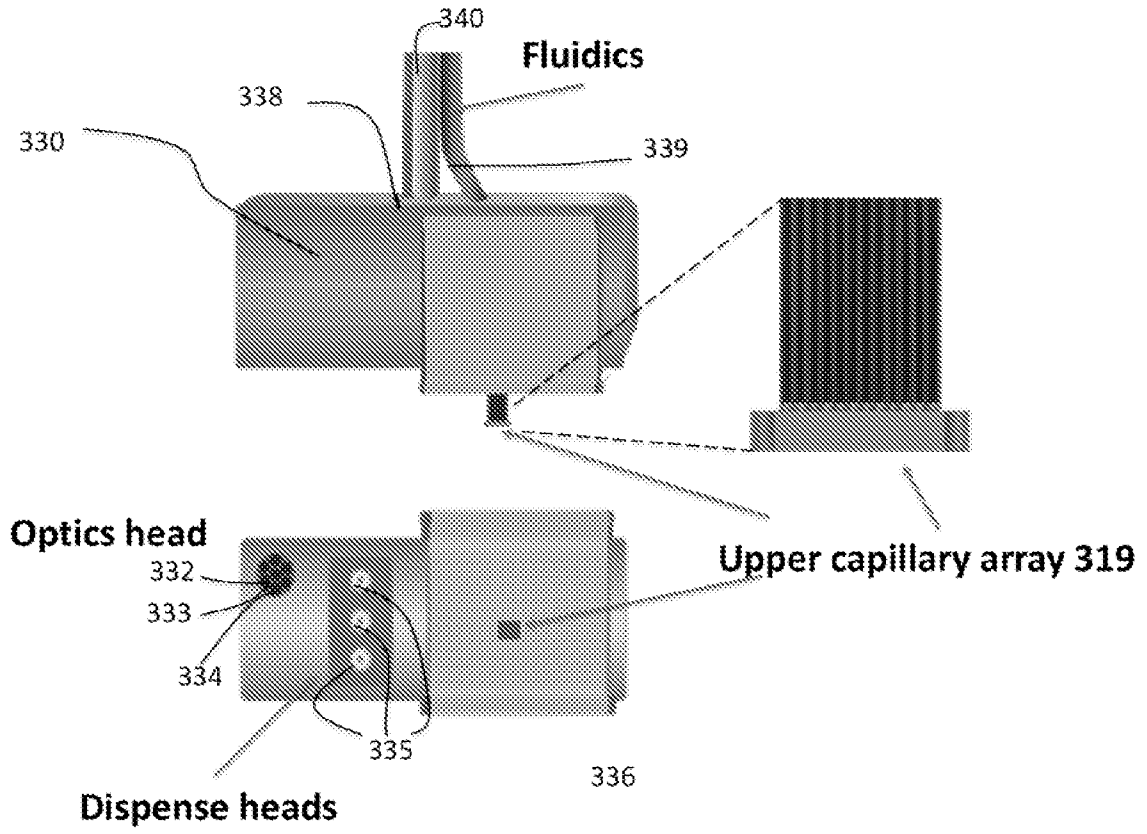

Figure 5

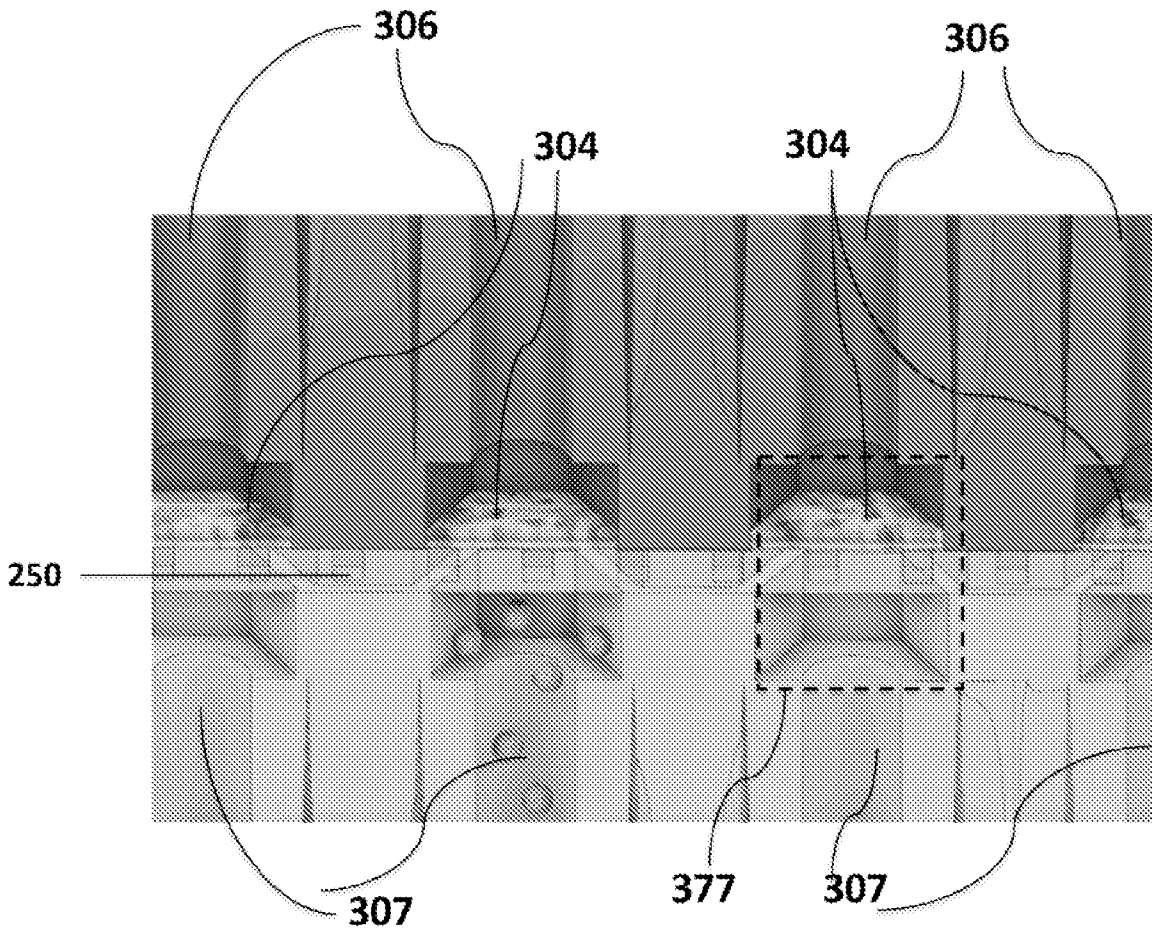

Figure 6

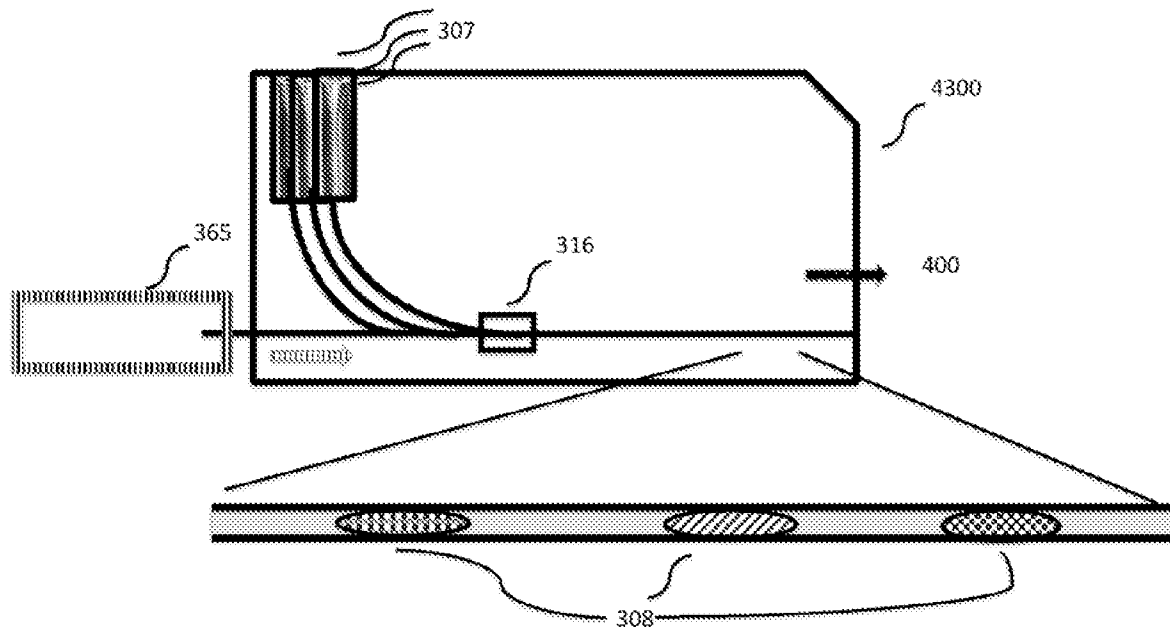
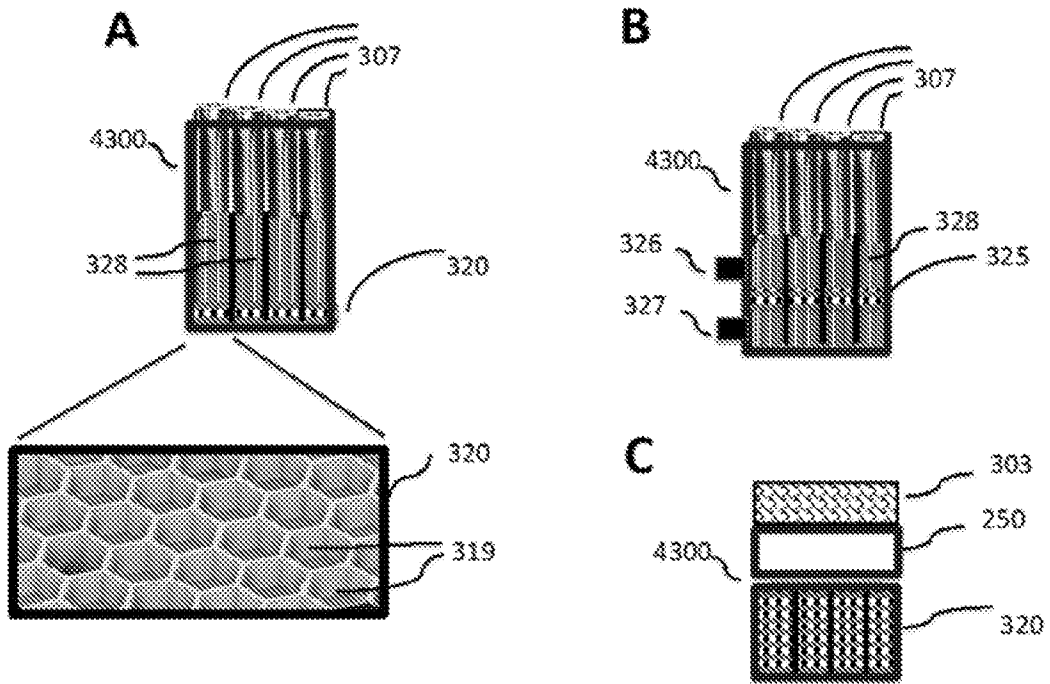

Figure 7



**Figure 8**

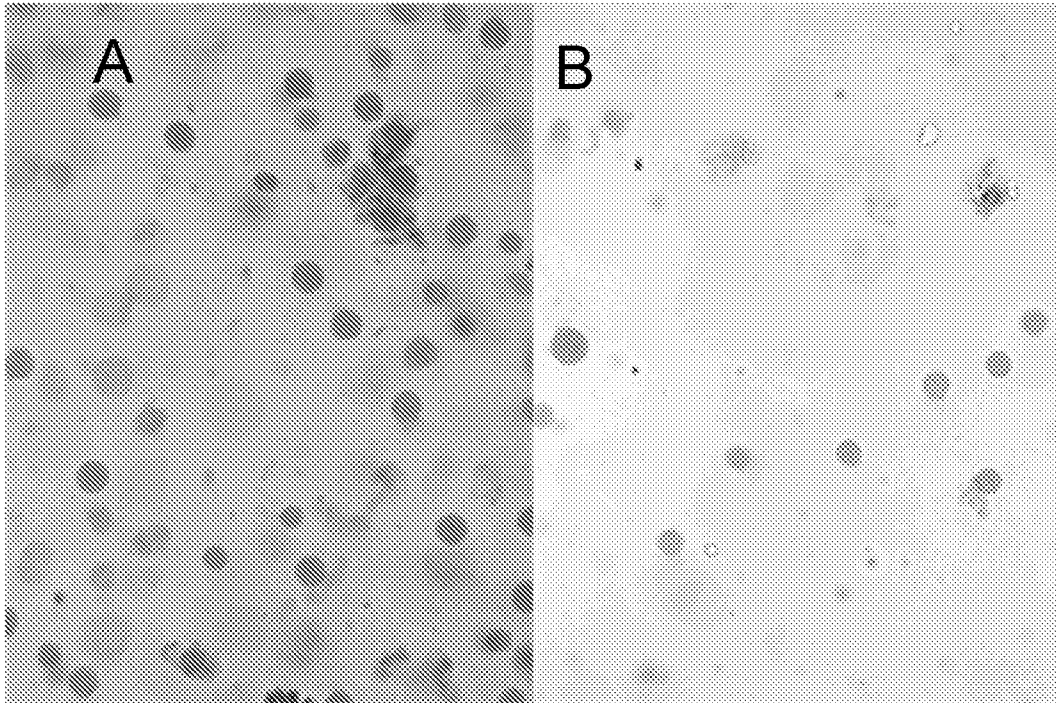

Figure 9

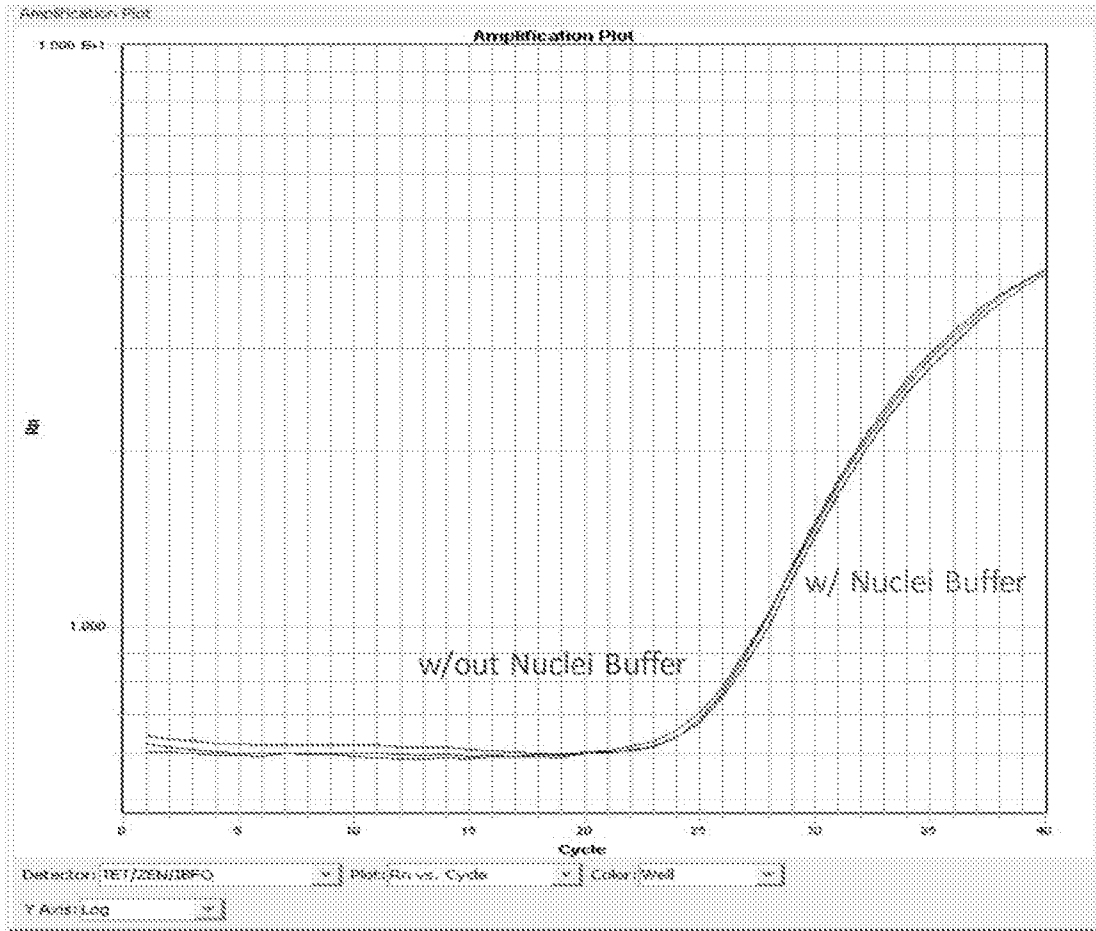

Figure 10

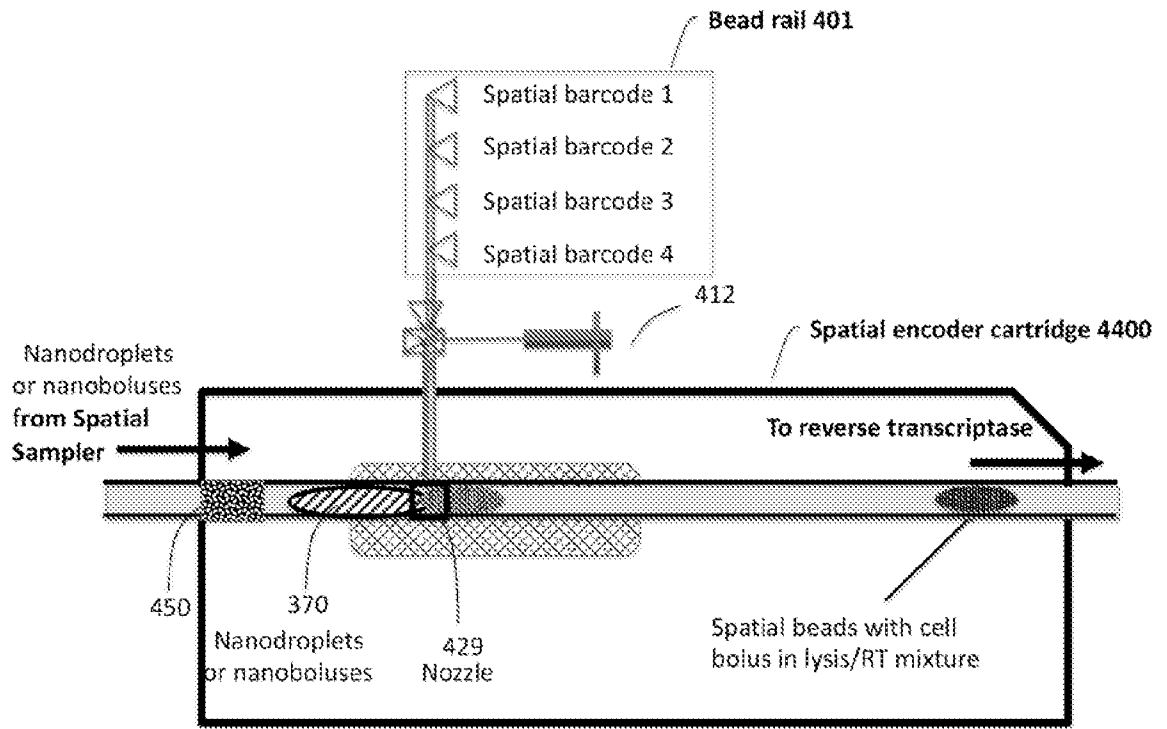

Figure 11

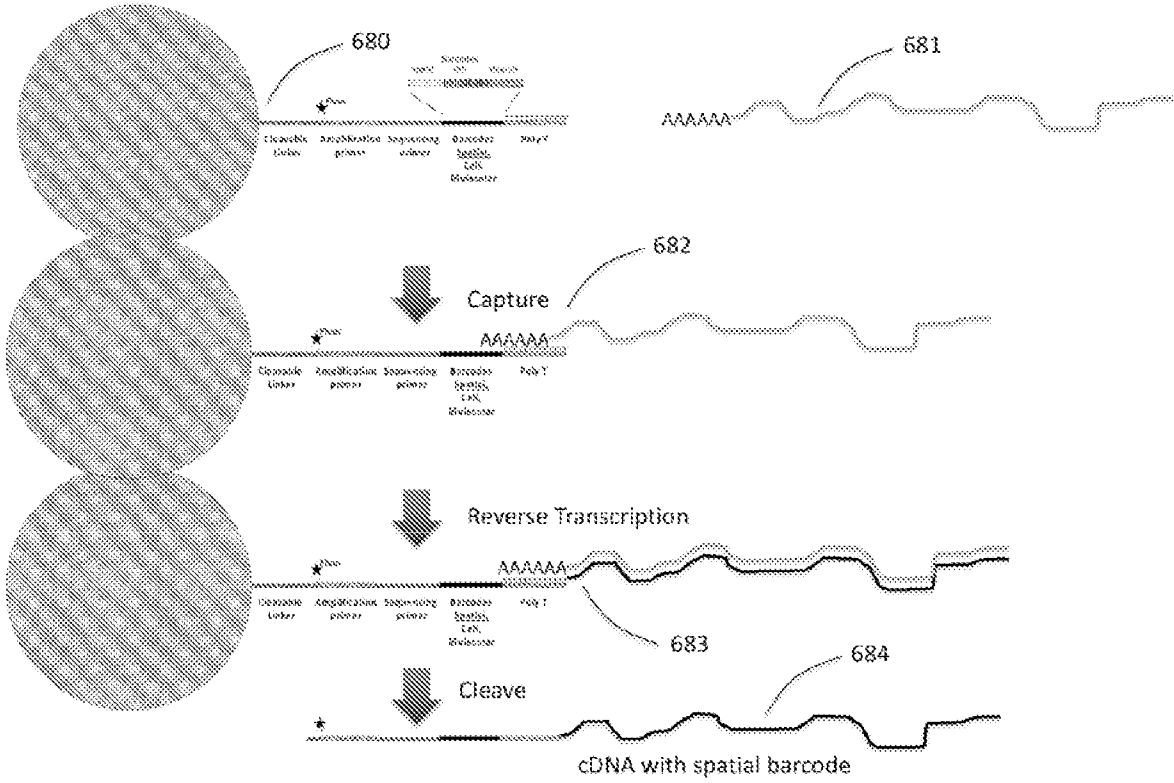
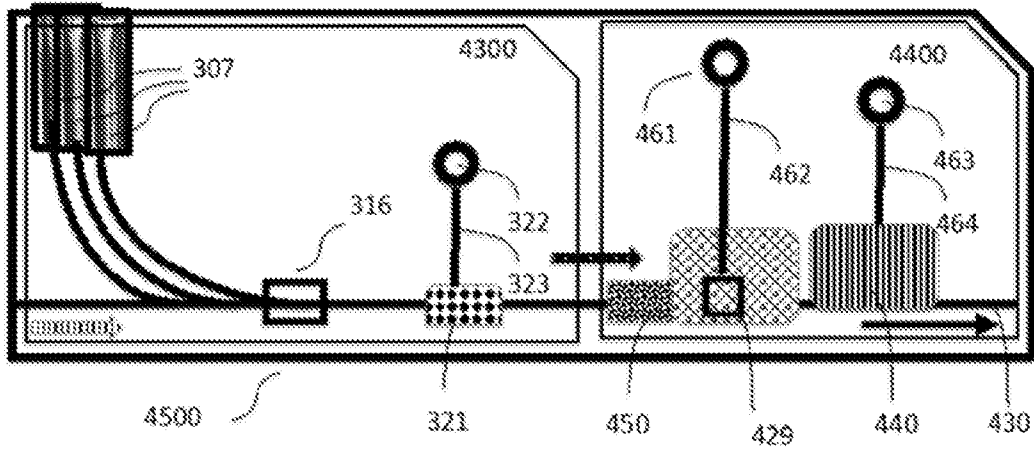

Figure 12



INTERNATIONAL SEARCH REPORT

International application No.

PCT/US 19/21942

**Box No. II Observations where certain claims were found unsearchable (Continuation of item 2 of first sheet)**

This international search report has not been established in respect of certain claims under Article 17(2)(a) for the following reasons:

1.  Claims Nos.:  
because they relate to subject matter not required to be searched by this Authority, namely:
  
2.  Claims Nos.:  
because they relate to parts of the international application that do not comply with the prescribed requirements to such an extent that no meaningful international search can be carried out, specifically:
  
3.  Claims Nos.:  
because they are dependent claims and are not drafted in accordance with the second and third sentences of Rule 6.4(a).

**Box No. III Observations where unity of invention is lacking (Continuation of item 3 of first sheet)**

This International Searching Authority found multiple inventions in this international application, as follows:  
 ----Go to Extra Sheet for continuation-----

1.  As all required additional search fees were timely paid by the applicant, this international search report covers all searchable claims.
2.  As all searchable claims could be searched without effort justifying additional fees, this Authority did not invite payment of additional fees.
3.  As only some of the required additional search fees were timely paid by the applicant, this international search report covers only those claims for which fees were paid, specifically claims Nos.:
4.  No required additional search fees were timely paid by the applicant. Consequently, this international search report is restricted to the invention first mentioned in the claims; it is covered by claims Nos.:  
1-37

- Remark on Protest**
- The additional search fees were accompanied by the applicant's protest and, where applicable, the payment of a protest fee.
  - The additional search fees were accompanied by the applicant's protest but the applicable protest fee was not paid within the time limit specified in the invitation.
  - No protest accompanied the payment of additional search fees.

**INTERNATIONAL SEARCH REPORT**

International application No.

PCT/US 19/21942

A. CLASSIFICATION OF SUBJECT MATTER  
 IPC(8) - C12M 3/06; C12M 3/08; C12N 15/00; G01N 1/28; B25J 9/06 (2019.01)  
 CPC - C12M 47/04; C12M 47/06; C12N 15/1003; C12N 15/1017; B25J 9/1045; G01N 2001/282

According to International Patent Classification (IPC) or to both national classification and IPC

B. FIELDS SEARCHED

Minimum documentation searched (classification system followed by classification symbols)

See Search History Document

Documentation searched other than minimum documentation to the extent that such documents are included in the fields searched

See Search History Document

Electronic data base consulted during the international search (name of data base and, where practicable, search terms used)

See Search History Document

C. DOCUMENTS CONSIDERED TO BE RELEVANT

Category*	Citation of document, with indication, where appropriate, of the relevant passages	Relevant to claim No.
Y	WO 2017/075293 A1 (SILICON VALLEY SCIENTIFIC) 4 May 2017 (04.05.2017) para [0019], [0021-0023], [0032], [0033], [0055], [0068], [0076], [0077], [0083], [0084], [0094], [00106], [00113], [00126], [00139], claim 44	1-37
Y	US 2013/0190212 A1 (HANDIQUE et al.) 25 July 2013 (25.07.2013) para [0032], [0038], [0099], [0100], sheet 1 fig 1, claim 1.	1-37
Y	PEREIRA et al. Development of Automated Processing of Tissue for Single Cell and Nuclei for Genomic Applications. AGBT meeting, February 2018 [online]. [Retrieved 24 June 2019]. Retrieved on the internet: <URL: <a href="https://s2genomics.com/news/">https://s2genomics.com/news/</a> >. Especially col 2 para 4.	18
Y	US 2002/0078778 A1 (GROVER et al.) 27 June 2002 (27.06.2002). Especially abstract, para [0038].	20

Further documents are listed in the continuation of Box C.

See patent family annex.

\* Special categories of cited documents:

"A" document defining the general state of the art which is not considered to be of particular relevance

"E" earlier application or patent but published on or after the international filing date

"L" document which may throw doubts on priority claim(s) or which is cited to establish the publication date of another citation or other special reason (as specified)

"O" document referring to an oral disclosure, use, exhibition or other means

"P" document published prior to the international filing date but later than the priority date claimed

"T" later document published after the international filing date or priority date and not in conflict with the application but cited to understand the principle or theory underlying the invention

"X" document of particular relevance; the claimed invention cannot be considered novel or cannot be considered to involve an inventive step when the document is taken alone

"Y" document of particular relevance; the claimed invention cannot be considered to involve an inventive step when the document is combined with one or more other such documents, such combination being obvious to a person skilled in the art

"&" document member of the same patent family

Date of the actual completion of the international search

24 June 2019

Date of mailing of the international search report

15 JUL 2019

Name and mailing address of the ISA/US

Mail Stop PCT, Attn: ISA/US, Commissioner for Patents  
 P.O. Box 1450, Alexandria, Virginia 22313-1450  
 Facsimile No. 571-273-8300

Authorized officer:

Lee W. Young

PCT Helpdesk: 571-272-4300  
 PCT OSP: 571-272-7774

## INTERNATIONAL SEARCH REPORT

International application No.

PCT/US 19/21942

Continuation of Box III: Observations where Unity of Invention is lacking

This application contains the following inventions or groups of inventions which are not so linked as to form a single general inventive concept under PCT Rule 13.1. In order for all inventions to be searched, the appropriate additional search fees must be paid.

Group I: Claims 1-37, drawn to a spatial sampler device configured to collect and transmit one or a plurality of cells or nuclei from a tissue specimen.

Group II: Claims 38-68, drawn to a method of disrupting cells in a tissue specimen to release one of a plurality of cells or nuclei, and collecting a microsample comprising one or a plurality of cells or nuclei.

The inventions listed as Groups I and II do not relate to a single general inventive concept under PCT Rule 13.1 because, under PCT Rule 13.2, they lack the same or corresponding special technical features for the following reasons:

Special Technical Features:

Group I has the special technical feature of a multifunctional head comprising an upper array of upper conduits and a lower carrier having an array of conduits for passing therethrough, not required by Group II.

Group II has the special technical feature of a method for disrupting cells in a tissue specimen to release one or more cells, not required by Group I.

Common Technical Features:

Groups I and II share the common technical features of:

1. Group II claim 59 depends from Group I claim 1.
2. A frozen biological tissue on a sample holder.
3. An array of conduits passing through a lower carrier connected to the sample holder above.

However, said common technical features do not represent a contribution over the prior art, and is disclosed by WO 2017/075293 A1 to Silicon Valley Scientific (hereinafter "SV Scientific"), in view of US 2013/0190212 A1 to Handique et al. (hereinafter "Handique").

As to common technical feature #1, instant claim 1, and common technical features #2 and #3, SV Scientific discloses a system comprising:

a) spatial sampler system configured to collect and transmit one or a plurality of cells or nuclei from a tissue specimen (para [0076]; "In a preferred embodiment, Spatial Sampler module 300 (i) releases cells from tissue, (ii) collects, and (iii) transfers single cells or groups of cells with defined spatial relationships in a known order"), the system comprising:

ii) a specimen holder (para [0032]; "the spatial sampler subsystem comprises: (1) a specimen holder") configured to support a frozen tissue specimen (para [0068]; "the tissue specimen is a solid tissue sample or a frozen tissue sample"),

iii) positioned, above the specimen holder, a multifunctional head comprising an upper array of upper conduits (para [0032]; "In one embodiment of the spatial preparation system: (i) the spatial sampler subsystem comprises: (1) a specimen holder, and (2) a multifunctional head comprising a transfer head comprising one or more extraction channels?... multifunctional head is mounted on a three-axis stage to position the multifunctional head to extract, by contact adhesion or by vacuum, the microsamples").

SV Scientific does not disclose that the specimen holder comprises a plurality of perforations having a size sufficient to permit the passage of cells and also does not disclose claim limitation i).

However, Handique discloses, the specimen holder comprises a plurality of perforations having a size sufficient to permit the passage of cells (claim 1; 1. A cell capture system comprising: an array defined on a broad face of a substrate [i.e. specimen holder], comprising: a plurality of parallel pores, each pore comprising: a chamber configured to hold a single cell; and a pore channel fluidly connected to the chamber"),

and also discloses claim limitation i) a lower carrier having an array of conduits passing therethrough, each conduit comprising an opening on a first side of the lower carrier and communicating with an opening on a second side, wherein the opening on the second side of the lower carrier either opens onto a well of a multiwell plate (claim 1; "A cell capture system comprising: an array defined on a broad face of a substrate, comprising: a plurality of parallel pores, each pore comprising: a chamber configured to hold a single cell; and a pore channel fluidly connected to the chamber").

----continued on next sheet----

**INTERNATIONAL SEARCH REPORT**

International application No.

PCT/US 19/21942

-----continued from previous sheet-----

It would have been obvious to combine SV Scientific with Handique, because it would have enabled a means to capture the extracted cells from the tissue specimen into conduits/pores below the specimen holder.

As the common technical features were known in the art at the time of the invention, they cannot be considered common special technical features that would otherwise unify the groups. The inventions lack unity with one another.

Therefore, Groups I and II lack unity of invention under PCT Rule 13 because they do not share a same or corresponding special technical feature.