

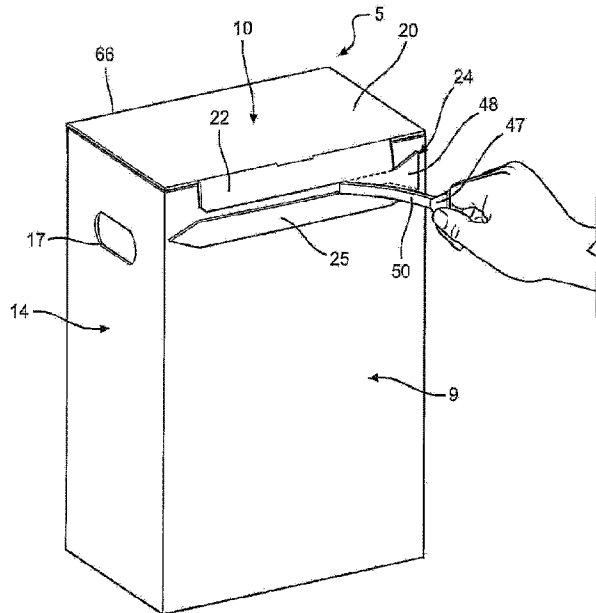

(86) Date de dépôt PCT/PCT Filing Date: 2022/08/09
 (87) Date publication PCT/PCT Publication Date: 2023/03/09
 (45) Date de délivrance/Issue Date: 2024/06/25
 (85) Entrée phase nationale/National Entry: 2024/02/29
 (86) N° demande PCT/PCT Application No.: US 2022/039778
 (87) N° publication PCT/PCT Publication No.: 2023/033996
 (30) Priorité/Priority: 2021/09/01 (US63/239,568)

(51) Cl.Int./Int.Cl. *B65D 5/28* (2006.01),
B65D 5/54 (2006.01), *B65D 5/66* (2006.01),
B65D 5/00 (2006.01), *B65D 17/28* (2006.01),
B65D 5/42 (2006.01), *B65D 5/64* (2006.01)
 (72) Inventeurs/Inventors:
 KANDOTH, NICOLE, US;
 KIM, DANIEL TAEK, US
 (73) Propriétaire/Owner:
 BLUE BUFFALO ENTERPRISES, INC., US
 (74) Agent: SMART & BIGGAR LP

(54) Titre : CARTON DOTE D'UN SYSTEME DE FERMETURE DE COUVERCLE INTEGRE
 (54) Title: CARTON WITH INTEGRAL COVER CLOSURE SYSTEM



(57) **Abrégé/Abstract:**

A carton (5) includes a first main body panel (60) spaced from a second main body panel (100) by first and second side panels (78, 134) and connected to the second main body panel (15) by a connector strip (25). With the removal of a tear strip (24), the connector strip (25) releases a cover (20) of the first main body panel (60) enabling an access opening to an internal storage region to be exposed. To close the carton (5), a lower top flap (106) of the second main body (100) is pivoted across the access opening, automatically causing multiple flap extensions (82, 87, 141, 146) of the side panels (78, 134) to fold beneath the lower top flap (106). Thereafter, the cover (20) is pivot atop the lower top flap (106) and a tab (22) of the cover (20) is received in a slot (112) formed at a juncture of the lower top flap (106) and a remainder of the second main body panel (100).

(12) INTERNATIONAL APPLICATION PUBLISHED UNDER THE PATENT COOPERATION TREATY (PCT)

(19) World Intellectual Property
Organization
International Bureau



(10) International Publication Number
WO 2023/033996 A1

(43) International Publication Date
09 March 2023 (09.03.2023)

(51) International Patent Classification:

B65D 5/28 (2006.01) *B65D 5/42* (2006.01)
B65D 5/54 (2006.01) *B65D 5/64* (2006.01)
B65D 5/66 (2006.01) *B65D 17/28* (2006.01)
B65D 5/00 (2006.01)

(21) International Application Number:

PCT/US2022/039778

(22) International Filing Date:

09 August 2022 (09.08.2022)

(25) Filing Language:

English

(26) Publication Language:

English

(30) Priority Data:

63/239,568 01 September 2021 (01.09.2021) US

(71) Applicant: **BLUE BUFFALO ENTERPRISES, INC.**
[US/US]; 11 River Road, Wilton, CT 06897 (US).

(72) Inventors: **KANDOTH, Nicole**; 28 High Avenue, Nyack, NY 10960 (US). **KIM, Daniel, Taek**; 428 Pascack Road, Town of Washington, NJ 07676 (US).

(74) Agent: **DIEDERIKS, Everett, G.**; Diederiks & Whitelaw, PLC, 4196 Merchant Plaza, #815, Woodbridge, VA 22192 (US).

(81) Designated States (*unless otherwise indicated, for every kind of national protection available*): AE, AG, AL, AM, AO, AT, AU, AZ, BA, BB, BG, BH, BN, BR, BW, BY, BZ, CA, CH, CL, CN, CO, CR, CU, CV, CZ, DE, DJ, DK, DM, DO, DZ, EC, EE, EG, ES, FI, GB, GD, GE, GH, GM, GT, HN, HR, HU, ID, IL, IN, IQ, IR, IS, IT, JM, JO, JP, KE, KG, KH, KN, KP, KR, KW, KZ, LA, LC, LK, LR, LS, LU, LY, MA, MD, ME, MG, MK, MN, MW, MX, MY, MZ, NA,

(54) Title: CARTON WITH INTEGRAL COVER CLOSURE SYSTEM

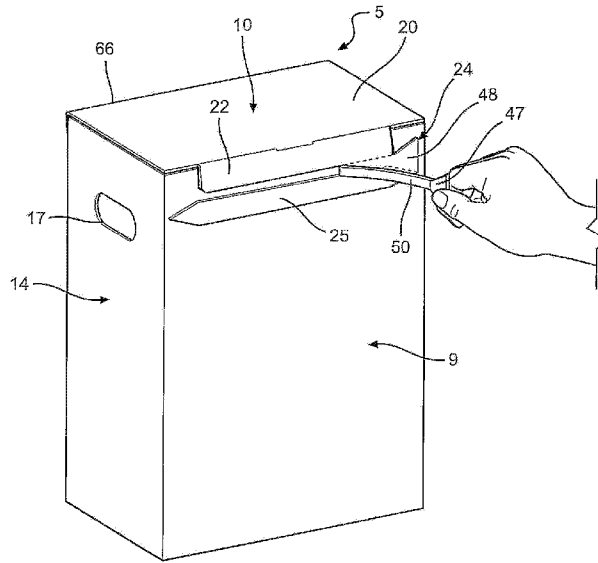
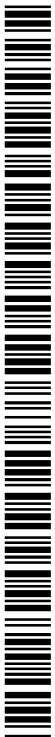

FIG. 5

(57) Abstract: A carton (5) includes a first main body panel (60) spaced from a second main body panel (100) by first and second side panels (78, 134) and connected to the second main body panel (100) by a connector strip (25). With the removal of a tear strip (24), the connector strip (25) releases a cover (20) of the first main body panel (60) enabling an access opening to an internal storage region to be exposed. To close the carton (5), a lower top flap (106) of the second main body (100) is pivoted across the access opening, automatically causing multiple flap extensions (82, 87, 141, 146) of the side panels (78, 134) to fold beneath the lower top flap (106). Thereafter, the cover (20) is pivoted atop the lower top flap (106) and a tab (22) of the cover (20) is received in a slot (112) formed at a juncture of the lower top flap (106) and a remainder of the second main body panel (100).



WO 2023/033996 A1

WO 2023/033996 A1 

NG, NI, NO, NZ, OM, PA, PE, PG, PH, PL, PT, QA, RO, RS, RU, RW, SA, SC, SD, SE, SG, SK, SL, ST, SV, SY, TH, TJ, TM, TN, TR, TT, TZ, UA, UG, US, UZ, VC, VN, WS, ZA, ZM, ZW.

- (84) Designated States** (*unless otherwise indicated, for every kind of regional protection available*): ARIPO (BW, GH, GM, KE, LR, LS, MW, MZ, NA, RW, SD, SL, ST, SZ, TZ, UG, ZM, ZW), Eurasian (AM, AZ, BY, KG, KZ, RU, TJ, TM), European (AL, AT, BE, BG, CH, CY, CZ, DE, DK, EE, ES, FI, FR, GB, GR, HR, HU, IE, IS, IT, LT, LU, LV, MC, MK, MT, NL, NO, PL, PT, RO, RS, SE, SI, SK, SM, TR), OAPI (BF, BJ, CF, CG, CI, CM, GA, GN, GQ, GW, KM, ML, MR, NE, SN, TD, TG).

Published:

- with international search report (Art. 21(3))
- with amended claims (Art. 19(1))

CARTON WITH INTEGRAL COVER CLOSURE SYSTEM

FIELD OF THE INVENTION

[0001] The invention generally pertains to packaging products, particular food products, in cartons and, more specifically, to a carton which is not only easy to initially open, but opening automatically establishes a cover and closure system enabling the carton to be readily and repeatedly opened and closed in a convenient and effective manner throughout its useful life.

BACKGROUND OF THE INVENTION

[0002] In connection with shipping products, such as food products, from a manufacturer to a retail establishment, it is known to package the products in a carton, seal the carton, and ship the carton for delivery to a designated retail establishment. Although various materials could be used in making the cartons, the most common material employed is paperboard. In general, the paperboard is provided in the form of a blank which can be conveniently stored in a flat configuration but easily erected through a simple folding operation to establish an open-ended carton which can be filled and sealed, typically in an automated process. These cartons are not only lightweight and quite strong, but the paperboard is advantageously recyclable.

[0003] In some situations, the cartons are designed with a closure system which enables the carton to be opened and closed numerous times prior to depleting the product therein. For example, it is widely known to package cereal and other food products in end load cartons and to provide the cartons with closure systems operating between upper and lower flaps of top portions of the cartons. In addition to end load cartons, top load cartons are popular for foods and other products. For example, donuts and other food products are often packaged in top load cartons, each including a cover which extends across an entire open top of the carton, with the cover being hinged to enable selective, repeated access to a product storage region of the carton.

[0004] Each of these known carton types has been employed in connection with storing and dispensing of animal food. Actually, there is a trend in the case of at least dry dog and cat foods to shift away from the large bags of food still found in many retail feed and grocery stores

to carton containers. By way of example, it has previously been proposed to provide a carton with a recloseable top which can be opened to expose an internal bag within which dry pet food is stored. These storage cartons have many advantages over large bags of the food. In particular, with both the internal reclosing of the bag and the external closure of the carton, the ability to contain the odor of the food from exiting the carton and effectively keep animals out of the food between feedings are greatly enhanced. The cartons also advantageously provide storing advantages over large food bags as the cartons can be readily stacked with similar cartons or other packaged products, whereas the large pet food bags do not afford this benefit.

[0005] Even with the advantages mentioned above, there are certain drawbacks from known carton designs employed in the industry. For instance, the mechanisms employed for opening such cartons can be difficult to start. By way of example, it is known to provide a tear strip for use in at least partially detaching the cover of the carton. However, known tear strip arrangements, if not clearly marked, can be overlooked by consumers, resulting in the carton being opened in another manner with loss of the reclosing feature. In addition, even using the tear strip often leads to a carton being damaged to an extent which limits the ability to adequately cover the open portion of the carton between uses. If the damage includes larger strips of the carton being torn off, handles provided in sidewalls of the carton for carrying the same can be compromised. Furthermore, there are unique problems experienced with dry pet food cartons which results in the need for a robust closure to prevent odors from escaping and pets from accessing the food. Also, as the bulk dispensing of the individual dry food pieces can be messy, there is a specific need in this art for a carton evincing better product retention. Based on the above, it is considered to exist a need in the art, particularly in the field of cartons for dry pet food, for a carton which includes a readily identifiable tear strip for opening of the carton while simultaneously establishing a cover for an access opening for the carton, with the cover including a closure mechanism which is robust and the carton is specifically structured to reduce the unintended loss or spillage of food pieces during dispensing operations.

SUMMARY OF THE INVENTION

[0006] The invention is directed to a packaging case or carton, preferably formed from a blank establishing first and second main body panels and first and second side panels, erected by directly interconnecting the first and second main body panels, spaced by the side panels, through a connector strip. The connector strip is formed as part of the first main body panel and spaced from a tongue or tab portion of a closure system by a tear strip having opposing starter strip portions. When the erected carton is initially sealed, the connector strip is adhesively secured to the second main body panel. When the carton is initially opened by removing the tear strip, a pivotable cover or lid is established, with the tab portion attached to the cover along a fold line. The cover, which is part of the first main body panel, establishes an upper top flap for the carton, while a lower top flap is part of and attached to a face panel portion of the second main body panel. At a juncture between the lower top flap and the face panel portion, a slot is formed. After initially being opened, the carton can be selectively closed by folding the cover over the lower top flap and inserting the tab portion into the slot.

[0007] As the invention is particularly designed for use in storing and dispensing of dry pet (e.g., cat or dog) food, the carton also preferably incorporates other enhancements. In particular, each of the side panels interconnecting the main body portions includes extension flaps which automatically fold upon each other upon lowering of the lower top flap, further sealing the carton. Correspondingly, when the cover and lower top flaps are open to expose an internal storage region of the carton, the extension flaps function as extensions of the sides of the carton. When using the carton to store and dispense dry pet food, these extensions can be particularly advantageous in containing the small pieces. The carton can include an internal bag in which the dry pet food is directly stored. The internal bag can be opened along a top seam and wrapped or otherwise sealed closed between uses to further prevent pet food odors emanating from the carton. In addition, one or more side carton handles can be provided to assist in carrying the carton, with each handle being formed as a full cut-out or by partially perforating a side portion of the carton which can be pivoted inward to enable fingers of the user to be inserted for lifting the carton.

[0008] Additional objects, features and advantages of the invention will become more readily apparent from the following detailed description when taken in conjunction with the drawings wherein like reference numerals refer to corresponding parts in the several views.

BRIEF DESCRIPTION OF THE DRAWINGS

[0009] Figure 1 is an upper perspective view of the carton constructed in accordance with the invention.

[0010] Figure 2 is a lower perspective view of the carton of Figure 1.

[0011] Figure 3 is a plan view of a paperboard blank from which the carton of Figures 1 and 2 is erected.

[0012] Figure 4 shows the carton of the invention during an initial opening stage.

[0013] Figure 5 shows a tear strip of the carton in a partially torn state.

[0014] Figure 6 shows the tear strip fully removed from a remainder of the carton.

[0015] Figure 7 shows a cover of the carton pivoting toward an opened condition.

[0016] Figure 8 shows the cover and carton in a closed condition.

[0017] Figure 9 shows the carton in a fully opened condition.

DETAILED DESCRIPTION OF INVENTION

[0018] With initial reference to Figures 1 and 2, a carton constructed in accordance with the present invention is generally indicated at 5. Carton 5 includes first and second opposing main sides (also referred to as first and second main face body portions) 8 and 9, a top side 10, a bottom side 12, and opposing sides 14 and 15. To assist in carrying carton 5, each of opposing sides 14 and 15 is preferably formed with a cutout, one of which is indicated at 17 for side 14, defining a handle (note another handle is shown at 18 in Figure 3). As best shown in Figure 1, top side 10 includes an upper top flap or cover 20 from which extends a tab 22 connected to a tear strip 24 and a connector strip 25 which is adhesively secured to second main side 9. On the other hand, with particular reference to Figure 2, bottom side 12 includes in-folded side flaps 31

and 32, as well as interlocking main or bottom flaps 34 and 35. As will be detailed more fully below, main flap 34 includes a tongue member 37 which is received in a recessed portion 38 of main flap 35. Circles 42 and 43 designate push areas on side flaps 31 and 32 to assist in breaking down carton 5 for recycling purposes after full use thereof. Before leaving Figures 1 and 2, further details of tear strip 24 are provided. More specifically, tear strip 24 includes terminal starter strip portions 47 and 48 which are interconnected by a central tear strip portion 50. Each starter strip portion 47, 48 establishes an enlarged gripping tab at a respective terminal end of tear strip 24. As will be described more fully below in reference to Figures 4-6, a select one of starter strip portions 47, 48 is meant to be grabbed by a user in initially opening carton 5 order to enable tear strip 45 to be removed. At this point, it should be noted that the use of terms, such as upper, lower, inner, outer, front, rear, side and the like, is for reference purposes only in describing exemplary forms of the invention as set forth herein and illustrated in the drawings. Therefore, these terms should not be considered limiting as to the overall invention.

[0019] In accordance with a preferred embodiment, carton 5 is formed from a blank 56 as shown in Figure 3. Blank 56 can be made from various materials, particularly cardboard which is widely known for use in the food industry for forming various types of food cartons. In any case, blank 56 is stamped from a single sheet to establish first opposing main side 8 which is defined by a first main body panel 60. First main body panel 60 includes an upper connecting fold line 66 leading to cover 20, as well as a lower connecting fold line 68 leading to interlocking main flap 35. As shown, main flap 35 includes spaced extensions 71 and 72 extending on either side of recessed portion 38. Connected to first main body portion 8 along a fold line 76 is side 15 which forms part of a first side panel 78. First side panel 78 includes an upper connecting fold line 80 leading to a first extension flap 82. On the other hand, first extension flap 82 is connected along a second fold line 85 to a second extension flap 87 which has associated therewith a third fold line 89. First side panel 78 also has side 15 connected to side flap 32 along a lower fold line 91. In the embodiment shown, side flap 32 includes a first, inwardly extending angled side edge 92 leading to a second, outwardly extending angled side edge 93, which collectively establishes an interlocking tab 95.

[0020] Side 15 is connected along a fold line 98 to a second main body panel 100 defined by, in part, second main face body portion 9. Second main body panel 100 has an associated lower top flap 106 connected to second main face body portion 9 along an upper connecting fold line 109. Therefore, fold line 109 defines a juncture between second main face body portion 9 of second main body panel 100 and lower top flap 106. At this juncture, an elongated slot 112 is formed. As shown, lower top flap 106 includes spaced ear portions 115 and 116 joined by a cross body portion 118. Ear portion 115 and one edge of cross body portion 118 are connected to second extension flap 87 along third fold line 89. Second main body panel 100 is also provided with a lower connecting fold line 121 leading to interlocking main flap 34. Main flap 34 is shown to include inwardly angled, opposing side edges 124 and 125 which lead to tongue member 37.

[0021] Carton 5 also includes a second side panel 134 connected along a fold line 136 to second main body panel 100. Second side panel 134 has an upper connecting fold line 138 joining side 14 with a first extension flap 141 which, in a manner similar to extension flap 82, is connected along a fold line 144 to a second extension flap 146. Second extension flap 146 is, in turn, also connected along a fold line 148 to lower top flap 106. More specifically, second extension flap 146, similar to second extension flap 87, is directly attached to ear portion 116 and part of cross body section 118 of lower top flap 106. Second side panel 134 is also connected to in-folded side flap 31 along a lower connecting fold line 153. Side flap 31 is basically a mirror image of side flap 32 and therefore includes a first angled side edge 157 leading to a second angled side edge 158 in defining an interlocking tab 161. Finally, blank 56 includes a fold line 167 between second side panel 134 and an attachment flap 170.

[0022] In assembling blank 56 of Figure 3 into carton 5 of Figures 1 and 2, the various panels are folded along lines 76, 98, 136 and 167, with attachment flap 170 being secured to first main body panel 60 with adhesive (not shown) to form a four-sided box. Thereafter, in-folded side flaps 31 and 32 are folded along lower connecting fold line 153 and lower connecting fold line 91 respectively, with tabs 95 and 161 being interlocked. Then, main flaps 34 and 35 are folded along lower connecting fold lines 121 and lower connecting fold line 68 respectively, with tongue member 37 being inserted within recessed portion 38 to arrive at the assembled

bottom side 22 shown in Figure 2. In closing off the remainder of carton 5, lower top flap 106 is folded along fold line 109. Based on the interconnection with each of second extension flaps 87 and 146, the folding of lower top flap 106 automatically causes first and second extension flaps 82 and 87, as well as first and second extension flaps 141 and 146, to fold upon each other beneath lower top flap 106. More specifically, when lower top flap 106 is fully opened or extended, each of first extension flaps 82 and 141 and second extension flaps 87 and 146 is arranged substantially perpendicular to lower top flap 106 as will be detailed further below with reference to Figure 9. In any case, when lower top flap 106 is pivoted to its fully lowered or closed position about an axis defined by fold line 109, each of extension flaps 82, 87, 141 and 146 are automatically oriented substantially parallel to lower top flap 106. Finally, cover 20 is folded along fold line 66 to lie over lower top flap 106 and each of tab 22, tear strip 24 and connector strip 25 are pivoted to be juxtapose second main side or face body portion 9, with connector strip 25 be secured, such as with adhesive (not shown), directly to second main side 9 to arrive at the arrangement shown in Figure 1. Obviously, at this point, carton 5 would have already been filled with the item(s) it was intended to store or protect.

[0023] Reference will now be made to Figure 4-6 in describing the manner in which carton 5 is initially opened. With initial reference to Figure 4, a user has selected to employ starter strip portion 47 in removing tear strip 24. To this end, starter strip portion 47 has been physically detached from connector strip 25 (note there is no direct connection between starter strip portion 47 and tab 22 which eases the ability to detach starter strip portion 47 as shown). In Figure 5, starter strip portion 47 has been pulled such that central tear strip portion 50 of tear strip 24 has extended a majority of the way across main side 9. This pulling of starter strip portion 47 (gripping tab) continues as central tear strip portion 50 is removed entirely from across main side 9 as represented in Figure 6. With tear strip 24 being completely removed, the adhesively secured connector strip 25 remains attached to second main face body portion 9 and upper top flap or cover 20 is now free to pivot about a hinge axis defined by fold line 66, while tab 22 remaining angled (generally perpendicular) to the plane of cover 20 as illustrated in Figure 6.

[0024] Figure 7 shows cover 20 initially pivoting relative to the remainder of carton 5. Here slot 112 can be seen. If it was desired to place carton 5 in a closed condition following initial opening, cover 20 need merely be lowered while guiding tab 22 into elongated slot 112. This closed condition is depicted in Figure 8. On the other hand, if cover 20 continues in the direction of the arrow in Figure 7 in having carton assume a fully opened condition of Figure 9, cover 20 is shifted so as to be completely removed from above inner top flap 106 and then inner top flap 106 can be lifted by grasping cross body section 118 from between ear portions 115 and 116. As referenced above, the raising or lowering of inner top flap 106 automatically causes side extensions 82, 87, 141 and 146 to be extended or deployed to achieve the opened condition depicted in Figure 9. That is, side extensions 82, 87, 141 and 146 automatically move from orientations substantially parallel and below upper top flap 106 when carton 5 is in the closed position of Figure 8 to being oriented substantially perpendicular to upper top flap 106 when carton 5 is in the opened position of Figure 9. This arrangement is seen to be quite advantageous. That is, although carton 5 could be used for storing and accessing a wide range of product, the most preferred use for carton 5 is packaging dry pet food, particularly for dogs or cats. In one form, cartons 5 made in accordance with the invention preferably define 10-30 lb. boxes for storing dry pet food which can be dispensed for feeding purposes over an extended period of time. In connection therewith, carton 5 may include a bag 180 containing the pet food, with the bag 180 being either rolled closed or otherwise sealed to retain odors, along with the closing of cover 20, between feedings. With the simultaneous upstanding arrangement of upper top flap 106 and side extensions 82, 87, 141 and 146, opening even a full bag 180 will not cause spillage and, as in the case of the dry pet food or other small, solid, stored pieces, these upstanding walls aid in containing the small pieces, particularly during dispensing operations.

[0025] At this point, it should be again noted that the terms like “upper”, “lower”, “front”, “rear” and “side” are only being used with reference to the embodiment depicted in the figures for use in explaining the invention. Therefore, by way of example, the carton could be rotated to make any side of the carton the “front” or “rear” without departing from the invention. In a preferred embodiment, first main face body portion 8 is used for the front of the carton as it presents a smooth, unincumbered surface for clearly displaying product label, logos and the like

information. In any case, it should be readily apparent that the invention provides for a carton which is convenient to initially open, advantageously expands upon opening and exhibits a simple and easy to use closure system. In any case, although disclosed with reference to preferred embodiments of the invention, it should be readily apparent that various changes and modifications can be made to the invention without departing from the spirit thereof. Instead, the invention is only intended to be limited by the scope of the following claims.

CLAIMS:

1. A carton comprising:
 - a first main body panel including a first main face body portion, a first bottom flap and a cover;
 - a second main body panel including a second main face body portion, a second bottom flap and a lower top flap;
 - first and second side panels connecting the first and second main body panels in a spaced relationship to establish an internal storage region of the carton, with the carton having an access opening into the internal storage region, wherein each of the first and second side panels includes a side panel portion and first and second extension flaps, with the first extension flap being directly connected to a respective said side panel portion along a first fold line, and the second extension flap being directly connected to both the first extension flap along a second fold line and the lower top flap along a third fold line; and
 - a closure system for selectively closing the access opening, said closure system including a tab formed with the cover and a slot provided at a juncture between the lower top flap and second main face body portion, with the tab being configured to be received in the slot upon pivoting the cover over the access opening.
2. The carton of claim 1, further comprising:
 - a tear strip directly attached to the tab of the cover; and
 - a connector portion attached to both the tear strip and the second main face body portion.
3. The carton of claim 2, wherein the tear strip includes spaced, terminal starter strips joined by a connector strip, said starter strips being enlarged relative to the connector strip to enhance gripping of a select one of the starter strips for removal of the tear strip.
4. The carton of claim 1, wherein one of the first bottom flap and the second bottom flap includes a recessed portion and another of the first bottom flap and the second bottom flap includes a tongue member, wherein the tongue member is received in the recessed portion in interlocking the first bottom flap with the second bottom flap.

5. The carton of claim 1, wherein the carton can assume a closed position, with the cover extending over the lower top flap and the tab being received in the slot, and an opened position wherein the each of the first and second side extensions extends substantially perpendicular to the lower top flap.
6. The carton of claim 5, wherein the each of the first and second side extensions extend substantially parallel to the lower top flap when the carton is in the closed position.
7. The carton of claim 6, wherein each of the first and second side extensions are located below the lower top flap when the carton is in the closed position.
8. The carton of claim 1, further comprising a handle provided in each of the first and second side panels.
9. The carton of claim 1, further comprising a bag in the internal storage region of the carton.
10. The carton of claim 9, further comprising dry pet food in the bag.
11. A unitary blank for forming a recloseable packaging carton, the blank comprising:
 - a first main body panel including a first main face body portion connected to a first bottom flap along a bottom fold line and a cover along a second fold line, said cover including a tab portion, with the tab portion being connected to a tear strip and a connecting strip;
 - a second main body panel including a second main face body portion connected to a second bottom flap along a lower fold line and to a lower top flap along an upper fold line, said second main body panel including a slot at a juncture between the second main face body portion and the lower top flap; and
 - first and second side panels each including a side panel portion and first and second extension flaps, with the first extension flap being directly connected to a respective said side

panel portion along a first fold line, and the second extension flap being directly connected to both the first extension flap along a second fold line and the lower top flap along a third fold line.

12. The unitary blank of claim 11, wherein one of the first bottom flap and the second bottom flap includes a recessed portion and another of the first bottom flap and the second bottom flap includes a tongue member, wherein the recessed portion is configured to receive the tongue member.

13. The unitary blank of claim 12, further comprising a handle provided in the side panel portion of each of the first and second side panels.

14. A method of opening and closing an openable top portion of a carton including first and second main body panels spaced by opposing side body panels and connected together through a connector strip, with each side body panel including first and second extension flaps, said method comprising:

initially opening the carton by: grasping and removing a tear strip formed as part of the first main body panel and attached to the second main body panel through the connector strip, with removal of the tear strip establishing a cover including a tab portion; pivoting the cover from atop an access opening of the carton; and pivoting a lower top flap of the second main body panel to expose the access opening; and

closing the openable top portion by: pivoting the lower top flap of the second main body panel across the access opening wherein, upon pivoting the lower top flap of the second main body panel, the first and second extension flaps are folded upon each other and automatically folded over the access opening; pivoting the cover over the lower top flap; and inserting the tab portion of the cover into a slot provided at a juncture between the lower top flap and a face panel portion of the second main body panel.

15. The method of claim 14, wherein the first and second extension flaps are substantially parallel to each other upon pivoting the lower top flap of the second main body panel across the access opening.

16. The method of claim 14, further comprising: re-opening the carton by: removing the tab portion from the slot; pivoting the cover from across the access opening; and pivoting the lower top flap from across the access opening while simultaneously unfolding each of the extension flaps.

17. The method of claim 16, wherein the first and second extension flaps are substantially perpendicular to the lower top flap upon fully pivoting the lower top flap from across the access opening.

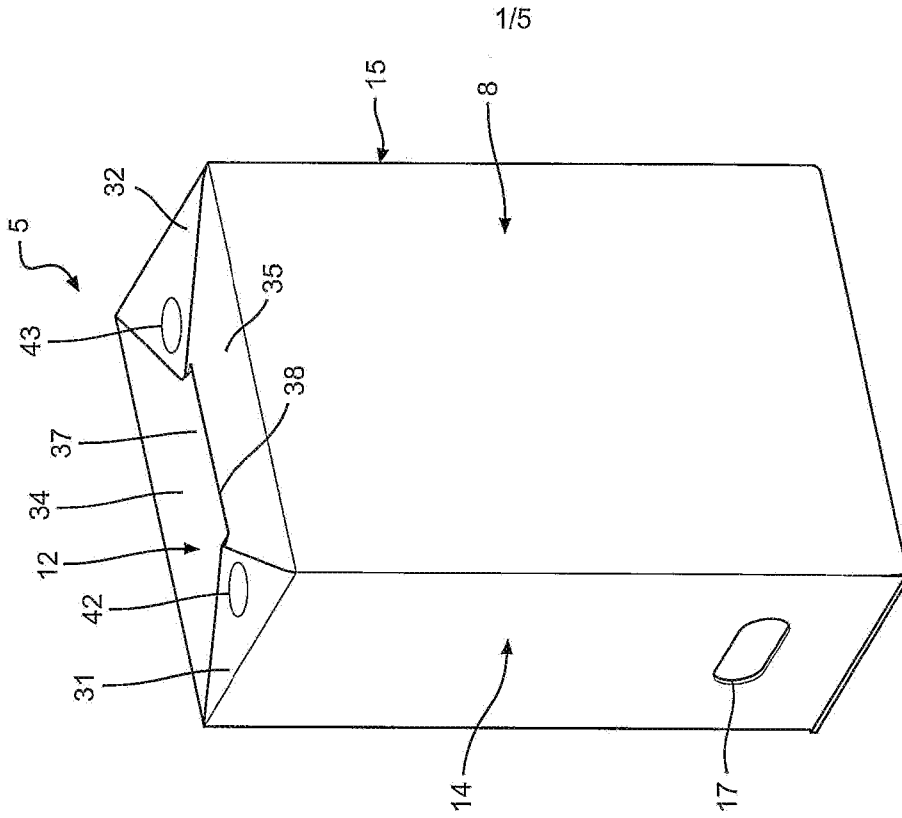

FIG. 1

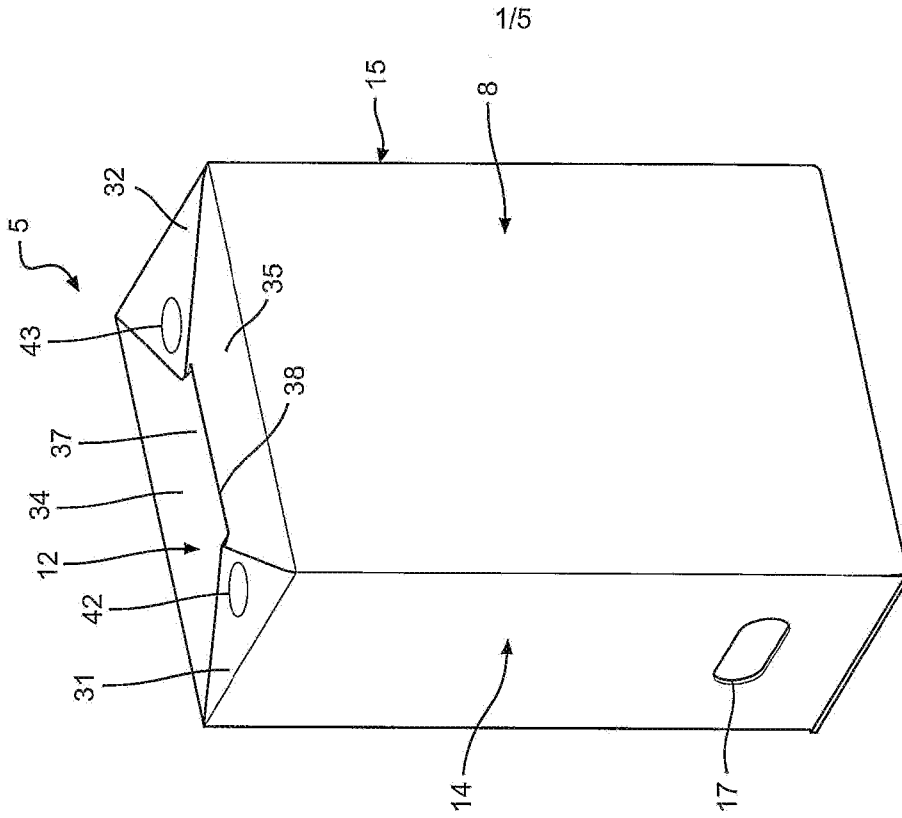
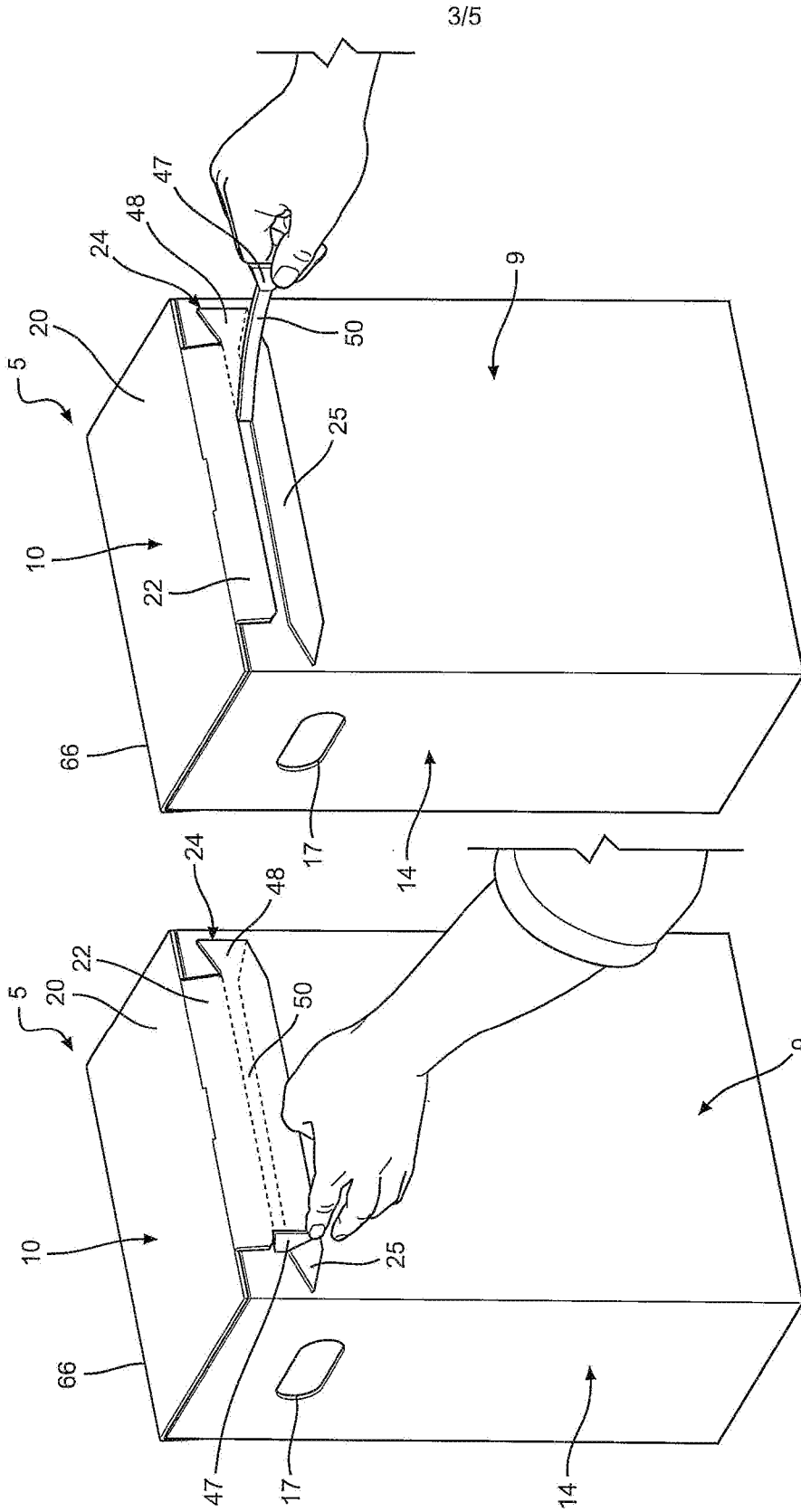

FIG. 2



4/5

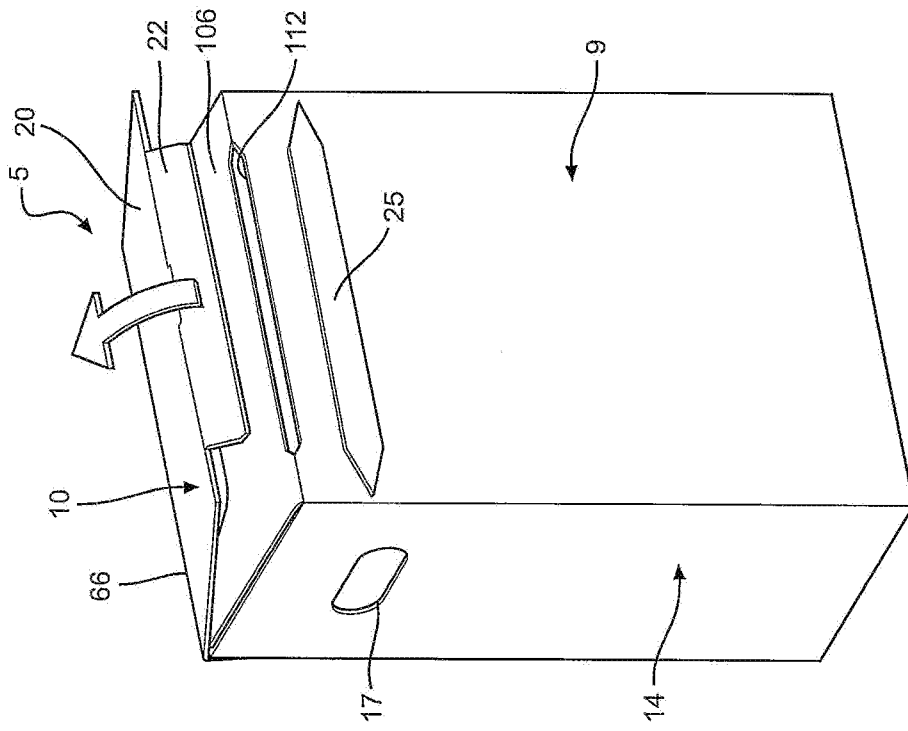

FIG. 7

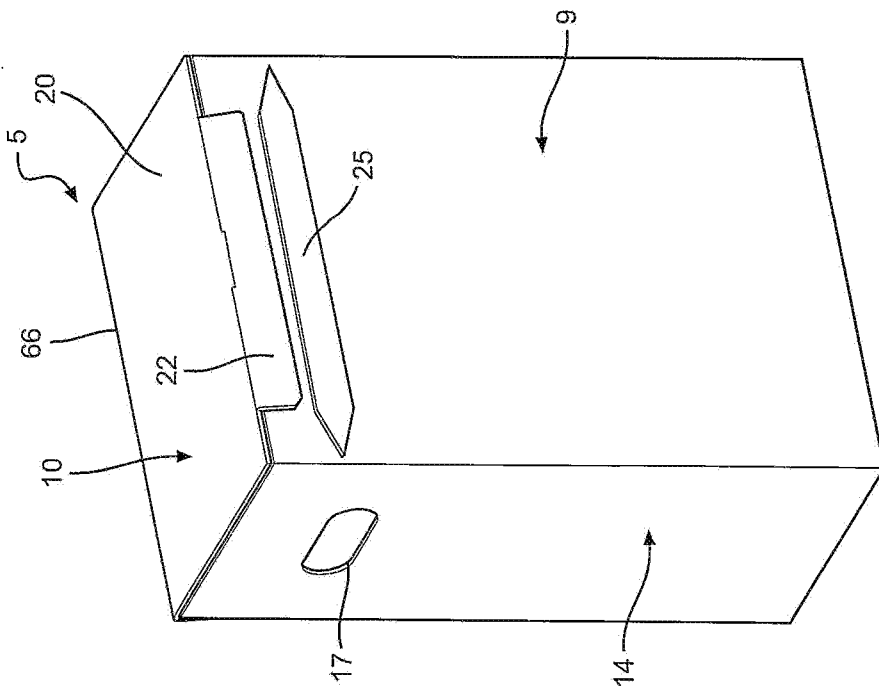

FIG. 6

