

(19)



Europäisches Patentamt

European Patent Office

Office européen des brevets



(11)

EP 0 467 334 B1

(12)

EUROPEAN PATENT SPECIFICATION

(45) Date of publication and mention
of the grant of the patent:
17.01.1996 Bulletin 1996/03

(51) Int. Cl.⁶: **B05B 7/12**, F16K 1/36,
F16K 41/00

(21) Application number: **91111954.3**

(22) Date of filing: **17.07.1991**

(54) Portable paint gun

Tragbare Farbspritzpistole

Pistolet de peinture portable

(84) Designated Contracting States:
CH DE DK FR GB IT LI NL

(30) Priority: **20.07.1990 US 553432**
03.08.1990 US 560744

(43) Date of publication of application:
22.01.1992 Bulletin 1992/04

(60) Divisional application : **94111252.6**

(73) Proprietor: **WAGNER SPRAY TECH
CORPORATION**
Minneapolis Minnesota 55447 (US)

(72) Inventors:
• **Frank, Peter L.**
Hamel, Minnesota 55340 (US)

- **Svensden, John M.**
Corcoran, Minnesota 55340 (US)
- **Steinberg, Timothy D.**
Coon Rapids, Minnesota 55433 (US)
- **Gunderson, Richard W.**
Elk River, Minnesota 55330 (US)

(74) Representative: **Liesegang, Roland, Dr.-Ing. et al**
D-80801 München (DE)

(56) References cited:
WO-A-91/11644 **DE-A- 2 737 680**
FR-A- 587 897 **GB-A- 799 991**
US-A- 1 875 438 **US-A- 2 888 207**
US-A- 4 560 109

EP 0 467 334 B1

Note: Within nine months from the publication of the mention of the grant of the European patent, any person may give notice to the European Patent Office of opposition to the European patent granted. Notice of opposition shall be filed in a written reasoned statement. It shall not be deemed to have been filed until the opposition fee has been paid. (Art. 99(1) European Patent Convention).

Description

The present invention relates to a portable paint gun and an air valve according to the preamble of claim 1. An air valve of this kind is shown in US-A-2 888 207 as comprising a generally cylindrical axially extending hub portion having a through bore, a radially outwardly projecting support portion mounted on the hub portion, and an outer rim portion on the support portion having a tapered sealing surface adapted for closing engagement with a valve seat.

In DE-A-2 737 680 an air valve for a spray gun is shown which comprises a first movable valve portion having a through bore and a second movable valve portion for closing and opening the first movable valve portion. The first movable valve portion has a tapered section and an axial recess within the region of the tapered section.

This invention pertains to the field of portable painting equipment, more particularly to portable paint guns referred to as high volume low pressure or HVLP type paint guns. In the past, such guns have been characterized by relatively complex and costly sealing mechanisms to prevent the escape of pressurized air from the interior of such guns. The present invention provides an improved apparatus for preventing the escape of pressurized air in a simple and efficient structure.

The present invention provides a portable paint gun and an air valve according to claim 1.

Figure 1 is a right side elevation view of the present invention with parts cut away and with movable parts shown in an OFF position.

Figure 2 is an enlarged side elevation detail of the shaft seal.

Figure 3 is an enlarged side elevation detail of the air valve.

Figure 4 is a fragmentary right side elevation view as seen in Figure 1 with movable parts in an intermediate position.

Figure 5 is a fragmentary right side elevation view with movable parts in an ON position.

Referring now to the drawings and more particularly to Figure 1, a portable paint gun 10 may be seen. Gun 10 has a handle 12 which is preferably hollow, and through which compressed air can pass when connected to a source of compressed air via fitting 14. Gun 10 further has a paint cup 16 having a siphon tube 18 to draw paint out of paint cup 16 in operation. Gun 10 further has a trigger 20 pivotably mounted to a gun body 22 via a trigger pin 24.

Gun 10 further has an air cap 26 retained by a locking ring 28 on body 22. An air cap spring 30 is preferably secured to a detent plate 32, as for example, by spot welding. Detent plate 32 preferably has projections 34, 36 which are retained respectively in slots 38, 40 to prevent rotation of plate 32. Plate 32 preferably has a cruciform opening interdigitated with projections on plate 32 (not shown) which are received in mating recesses (not shown) in air cap 26. The detents in plate 32 and

recesses in cap 26 cooperate to hold cap 26 in one of three predetermined positions to provide for control of the paint pattern in a manner well known. Gun 10 further has a fluid nozzle 42 which cooperates with a needle 44 to form a needle or paint valve 46 to control the flow of paint or other material delivered by gun 10. A needle packing nut 48 is preferably threaded into body 22 to compress needle packing 50 against needle 44.

Gun 10 also has an air passageway 52 in communication with a plenum 54 surrounding fluid nozzle 42. Plenum 54 is in communication with recess 56 in air cap 26. Trigger 20 is in contact with an air valve shaft 58 surrounding needle 44 and carrying an air valve 60. An air plug 62 is preferably threaded into body 22 to close off an alternative inlet to passageway 52. In the configuration shown in Figure 1, gun 10 is arranged for "non-bleeder" operation. By interchanging plug 62 with fitting 14, and supplying air directly to passageway 52, gun 10 would be configured for "bleeder" operation.

Valve 60 is retained on shaft 58 by a retaining ring 64 on one side of valve 60 and by a flange 66 on the other side of valve 60. Valve 60 is urged toward a mating seat 68 by an air valve spring 70. Air valve spring 70 is also in contact with a shaft seal 72. Shaft seal 72 seals shaft 58 against a material adjustment housing 74 threaded into gun body 22. A needle spring 76 is retained by a material adjustment knob 78 threaded on housing 74 and spring 76 urges needle 44 forward against nozzle 42 to maintain needle valve 46 in a closed position.

A bushing 79 preferably formed of plastic serves as a guide and air seal around shaft 58 and holds shaft 58 and needle 44 in alignment during assembly and operation of gun 10. It is to be understood that bushing 79 need not be an "air-tight" seal since it only needs to prevent air leakage along shaft 58 when valve 60 is in the intermediate and ON positions.

Referring now more particularly to Figure 2, various details of the shaft seal 72 may be seen. Seal 72 has a mediate portion 80 having a radially outwardly projecting flange 82 and a generally cylindrical interior recess 84 located radially inwardly of the flange 82. Seal 72 further has a first conical rim 86 extending axially in a first direction away from flange 82 with a shallow conical taper from a relatively thicker cross-section 88 proximal of the flange 82 to a relatively thinner cross-section 90 distal of flange 82. Shaft seal 72 further has a first extension 92 of the generally cylindrical interior recess 84 with extension 92 located radially inwardly of surface 86.

Seal 72 further has a second conical rim 94 extending axially in a second direction opposite the first direction away from flange 82 and further has a second extension 96 of the generally cylindrical interior recess 84 extending axially along and radially inward of rim 94.

Rim 94 of seal 72 has a conical inner surface 98 extending from the second extension 96 of the generally cylindrical interior recess 84 to a cylindrical shaft sealing surface 100 which is located axially distal of the flange 82 in the second direction. Rim 94 also has a tapered sealing surface 102 having an external conical taper

adapted for contacting and interfitting with a mating correspondingly tapered bore or chamfer 104 in element 74 of paint gun 10 such that shaft seal 72 prevents the passage of air between the control shaft 58 and the shaft sealing surface 100 and also from between the sealing surface 102 and the tapered bore 104 when pressurized air is present in chamber 106.

It is to be understood that first conical rim 86 is sized to mate in an interference fit with cylindrical compression spring 70 to retain seal 72 on spring 70 when gun 10 is disassembled. It is further to be understood that spring 70 acts against flange 82 to urge seal 72 in the second direction with respect to the control shaft 58. In a preferred embodiment, the first conical rim 86 tapers from 0.228 inches diameter to 0.311 inches diameter and the spring 70 has an internal diameter of 0.316 inches.

It is further to be noted that the tapered sealing surface 102 of conical rim 94 preferably has a taper substantially equal to a taper of the conical inner surface 98 providing a constant cross-sectional thickness of rim 94 between surfaces 98 and 102. It is further to be understood that the cylindrical interior recess 84, along with its extensions 92, 96 preferably has a diameter substantially greater than the diameter of the control shaft around which the seal 72 is located such that there is a radial clearance between shaft 58 and recess 84, together with its extensions 92, 96. Furthermore, the shaft sealing surface 100 preferably has an axial length that is relatively short with respect to the axial length of the overall shaft seal 72 (e.g. less than ten percent) such that the resistance to relative axial movement between the control shaft 58 and the seal 72 is minimized.

In a preferred embodiment, surface 100 is 0.025 inches long while seal 72 is 0.365 inches long overall. Surfaces 98, 102 and 104 each preferably have a conical taper of 30 degrees.

In operation, pressure from spring 70 forces seal 72 against the tapered bore or chamfer 104 in the material adjustment housing 74 creating an airtight seal. Axial force or pressure generated by spring 70 is transferred to a radial force by the interaction of surfaces 102, 104 thus urging surface 100 against shaft 58 (making use of the conical flexibility of rim 94), forming an airtight seal. As seal 72 wears at surface 100, seal 72 is permitted to move axially in the second direction as urged by spring 70 to maintain sufficient pressure to insure sealing between shaft 58, seal 72 and housing 74.

Referring now more particularly to Figure 3, various details of the air valve 60 may be seen. Valve 60 has a generally cylindrical axially extending hub portion 110 having a through bore 112, a radially outwardly projecting support portion 114 mounted on the hub portion 110, and a generally conical outer rim portion 116 extending coaxially with hub portion 110 and mounted on support portion 114 radially outwardly of hub portion 110. Rim portion 116 has a tapered sealing surface 118 adapted for matingly interfitting with a tapered valve seating surface 120 in the body 22 of gun 10. Valve 60 further has an axial recess 122 located in a region radially inward of

the tapered sealing surface of rim portion 116. The hub portion 110 of valve 60 has a first shoulder 124 and a second shoulder 126 for locating the valve in first and second axial directions on shaft 58. Shoulder 124 is held by retaining ring 64 and shoulder 126 is held by flange 66 on shaft 58.

Both seal 72 and valve 60 are preferably formed of a relatively resilient material such as virgin polytetrafluoroethylene as sold under the trademark TEFLON by E.I. DuPont de Nemours Co. The material of valve 60 is preferably homogeneous with the rim portion 116 being relatively flexible with respect to the hub and support portions 110, 114 such that sealing surface 118 conforms to the seating surface 120 when valve 60 is drawn against the seating surface 120. Surface 118 preferably has an external conical angle 128 of 16 degrees, while seating surface 120 preferably has an internal conical angle 130 of 18 degrees.

Rim portion 116 provides a "forgiving" alignment between seal 60 and seating surface 120. The flexibility of rim portion 116 allows the tapered sealing surface 118 to conform to radial and axial misalignment between seal 60 and gun body 22. Because angle 130 is greater than angle 128, a leading edge 132 of the sealing surface 118 will contact surface 120 first. It has been found preferable that hub portion 110 and support portion 114 are relatively rigid with respect to rim portion 116 which is relatively conically flexible and provides a secondary seal area along surface 118 distal of leading edge 132, thus compensating for creep or cold flow of lip portion 116 during the operating lifetime of gun 10. The rigidity of support portion 114 also provides a radial clearance protection of rim portion 116 to reduce the possibility of damage during storage and handling of valve 60 prior to assembly into gun 10.

Referring now to Figures 4 and 5, along with Figure 1, the operation of the air valve and seal is as follows:

In Figure 1, the gun is shown in an OFF position with both the paint or needle valve 46 and air valve 60 in a closed position. Paint valve 46 is closed when needle 44 is its forwardmost position and is contacting the interior of fluid nozzle 42. Air valve 60 is in the closed position when control shaft 58 is in the forwardmost or closed position. With the gun configured for "non-bleeder" operation, retracting trigger 20 from the OFF or closed position shown in Figure 1 to an intermediate position as shown in Figure 4, will move control shaft 58, but not needle 44, thus opening passageway 52 to the source of pressurized air by moving air valve 60 away from seating surface 120 permitting the passage of air therethrough. Further progression of trigger 20 from the position shown at Figure 4 to the position shown in Figure 5 will move the control shaft 58 axially within seal 72 further in the second direction causing the control shaft to drive needle 44 against spring 76 opening the needle valve 46.

Thus, it may be seen that in Figure 1, both the paint valve 46 and the air valve 60 are in the OFF position. In Figure 4, the air valve 60 is in the ON position while the paint valve 46 remains in the OFF position. In Figure 5,

both the paint valve 46 and the air valve 60 are in the ON position.

It is to be understood that as trigger 20 is released, the paint valve 46 will move to the OFF position as shown in Figure 4, while the air valve 60 will remain ON, thus clearing paint from air cap 26 and the exterior of fluid nozzle 42. Further release of trigger 20 will permit movement of control shaft 58 to the closed position for air valve 60 such that the sealing surface 118 conforms to the seating surface 120 when the control shaft is in the closed position of Figure 1. It can thus be seen that the mating, sealing and seating surfaces 118, 120 are in contact with each other when the control shaft 58 is in a closed position and the sealing and seating surfaces 118, 120 are axially spaced from each other when the control shaft 58 is displaced axially away from the closed position. It is to be understood that seal 72 maintains an air seal between itself and control shaft 58 in each of the positions shown in Figures 1, 4 and 5 and while shaft 58 is moving among those positions.

The invention is not to be taken as limited to all of the details thereof as modifications and variations thereof may be made without departing from the scope of the claims.

Claims

1. A portable paint gun (10) comprising a control shaft (58) for controlling a supply of pressurized air to atomize a selectively provided stream of paint, and an air valve (60) comprising:
 - a) a generally cylindrical axially extending hub portion (110) having a through bore (112) closely interfitting with the shaft (58);
 - b) a radially outwardly projecting support portion (114) mounted on the hub portion; and
 - c) a generally conical outer rim portion (116) extending coaxially with said hub portion (110) and mounted on the support portion (114) radially outwardly of the hub portion and having a tapered sealing surface (118) adapted for matingly interfitting with a tapered valve seating surface (120) in the gun
2. The paint gun of claim 1 wherein the hub portion (110) further comprises first and second shoulder means (124, 126) for respectively locating the valve in first and second axial directions on the shaft (58).
3. The paint gun of claim 1 or 2, wherein the valve (60) is formed of a relatively resilient material.
4. The paint gun of claim 3, wherein the valve (60) is formed of homogeneous material and wherein the rim portion (116) is relatively flexible with respect to the hub and support portions (110, 114) such that the sealing surface (118) conforms to the seating surface (120) when the control shaft (58) is in the closed position.
5. The paint gun of claim 3 or 4, wherein the valve (60) is formed of polytetrafluorethylene.
6. The paint gun of one of the preceding claims, wherein the outer rim portion (116) further comprises leading edge means (132) for initiating contact between the tapered sealing and seating surfaces (118, 120) as the valve (60) moves to the closed position.
7. The paint gun of claim 6, wherein the outer rim portion (116) conically deforms to provide contact between the mating sealing and seating surfaces (118, 120) such that at least a conforming portion of the sealing surface assumes a conical taper equal to the conical taper of the valve seating surface when the valve (60) is closed.
8. The paint gun of claim 7, wherein the conforming portion further comprises a secondary sealing portion such that sealing against air leakage is maintained in the presence of creep and cold flow of the outer rim portion while the valve is in the closed position.

wherein the mating sealing and seating surfaces are in contact with each other when the control shaft is in a closed position, and wherein the sealing and seating surfaces are axially spaced from each other when the control shaft is displaced axially from the closed position, **characterized** in that the air valve (60) comprises an axial recess (122) in a region radially inwardly of the tapered sealing surface (118), and that the tapered sealing surface (118) has a conical taper less than the conical taper of the valve seating surface (120).

Patentansprüche

1. Tragbare Farbspritzpistole (10), mit einem Steuerungselement (58) zum Steuern der Zuführung von Druckluft, um einen wahlweise vorgesehenen Farbstrom zu zerstäuben, und mit einem Luftventil (60), welches folgende Merkmale aufweist:
 - a) ein im wesentlichen zylindrischer, sich axial erstreckender Nabenabschnitt (110), der eine Durchgangsbohrung (112) aufweist, welche genau mit dem Schaft (58) zusammenpaßt,
 - b) ein radial nach außen vorspringender Stützabschnitt (114), der an dem Nabenabschnitt montiert ist, und
 - c) ein im wesentlichen konischer äußerer Randabschnitt (116), welcher sich koaxial zu dem Nabenabschnitt (110) erstreckt und an dem

Stützabschnitt (114) radial außerhalb des Nabenabschnitts montiert ist und eine abge-
schrägte Dichtfläche (118) aufweist, welche
passend mit einer abgechrägten Ventilsitz-
fläche (120) in der Spritzpistole zusammenge-
bracht werden kann,

wobei die passenden Dicht- und Sitzflächen mitein-
ander in Kontakt sind, wenn der Steuerschaft in
einer geschlossenen Position ist, und wobei die
Dicht- und Sichtflächen axial gegeneinander ver-
setzt sind, wenn der Steuerschaft relativ zu der
geschlossenen Position axial verschoben ist,
dadurch gekennzeichnet, daß

das Luftventil (60) eine axiale Aussparung (122) in
einem Bereich aufweist, der radial innerhalb von der
abgechrägten Dichtfläche (118) liegt, und daß
die abgechrägte Dichtfläche (118) eine konische
Abschrägung aufweist, die geringer ist als die
konische Abschrägung der Ventilsitzfläche (120).

2. Farbspritzpistole nach Anspruch 1, bei welcher der
Nabenabschnitt (110) ferner eine erste und eine
zweite Schultereinrichtung (124, 126) aufweist, um
das Ventil in einer ersten bzw. einer zweiten axialen
Richtung auf dem Schaft (58) zu positionieren.
3. Farbspritzpistole nach Anspruch 1 oder 2, bei der
das Ventil (60) aus einem relativ elastischen Werk-
stoff hergestellt ist.
4. Farbspritzpistole nach Anspruch 3, bei der das Ven-
til (60) aus einem homogenen Werkstoff hergestellt
ist und bei der der Randabschnitt (116) in Bezug auf
den Nabenabschnitt und den Stützabschnitt (110,
114) relativ nachgiebig ist, so daß sich die Dichtfläche
(118) an die Sitzfläche (120) anpaßt, wenn sich der
Schaft (58) in der geschlossenen Position
befindet.
5. Farbspritzpistole nach Anspruch 3 oder 4, bei der
das Ventil (60) aus Polytetrafluorethylän hergestellt
ist.
6. Farbspritzpistole nach einem der vorangehenden
Ansprüche, bei welcher der äußere Randabschnitt
(116) ferner eine vordere Kantenvorrichtung (132)
aufweist, um einen Kontakt zwischen den abge-
schrägten Dicht- und Sitzflächen (118, 120) ein-
zuleiten, wenn sich das Ventil (60) in die
geschlossene Position bewegt.
7. Farbspritzpistole nach Anspruch 6, bei welcher der
äußere Randabschnitt (116) sich konisch verformt,
um einen Kontakt zwischen den passenden Dicht-
und Sitzflächen (118, 120) vorzusehen, so daß
mindestens ein sich anpassender Abschnitt der
Dichtfläche eine konische Abschrägung annimmt,

die gleich der konischen Abschrägung der Ventilsitz-
fläche ist, wenn das Ventil (60) geschlossen ist.

8. Farbspritzpistole nach Anspruch 7, bei welcher der
sich anpassende Abschnitt ferner einen zweiten
Dichtabschnitt aufweist, so daß eine Abdichtung
gegen ein Entweichen von Luft aufrechterhalten
wird, wenn eine allmähliche Verformung und kaltes
Fließen des äußeren Randabschnittes auftritt,
während sich das Ventil in der geschlossenen Posi-
tion befindet.

Revendications

1. Un pistolet de peinture portable (10) comprenant un
arbre de commande (58) destiné à commander l'ali-
mentation d'air comprimé pour atomiser un courant
de peinture fourni sélectivement et une soupape
d'air (60), comprenant:

(a) une partie moyeu (110) s'étendant axiale-
ment et de forme globale cylindrique, ayant un
trou traversant (112) venant s'adapter intime-
ment avec l'arbre (58);

(b) une partie support (114) faisant saillie radi-
alement extérieurement montée sur la partie
moyeu; et

(c) une partie bordure extérieure (116) globale-
ment conique s'étendant coaxialement par rap-
port à ladite partie moyeu (110) et montée sur
la partie support (114), ce projetant radialement
extérieurement de la partie moyeu et ayant une
surface d'étanchéité (118) chanfreinée, adap-
tée pour coopérer avec ajustement avec une
surface de portée de soupape (120) effilée, réal-
isée dans le pistolet,

dans lequel les surfaces d'étanchéité et de portée
qui s'adaptent mutuellement, sont placées en con-
tact entre elles, lorsque l'arbre de commande se
trouve en position fermée, et dans lequel les sur-
faces d'étanchéité et de portée sont espacées axi-
alement l'une de l'autre lorsque l'arbre de
commande est déplacé axialement depuis la posi-
tion fermée,
caractérisé en ce que la soupape à air (60) com-
prend une cavité axiale (122) ménagée dans une
zone radialement intérieure de la surface
d'étanchéité (118) chanfreinée, et en ce que
la surface d'étanchéité chanfreinée (118) a une
conicité inférieure à la conicité de la surface de
portée de soupape (120).

2. Le pistolet à peinture selon la revendication 1, dans
lequel la partie moyeu (110) comprend en outre des
premier et deuxième moyens d'épaulement (124,
126) destinés à positionner respectivement la sou-

pape dans des première et deuxième directions axiales de l'arbre (58).

3. Le pistolet à peinture selon la revendication 1 ou 2, dans lequel la soupape (60) est constituée d'un matériau relativement élastique. 5

4. Le pistolet à peinture selon la revendication 3, dans lequel la soupape (60) est constituée d'un matériau homogène et dans lequel la partie de bord (116) est relativement flexible par rapport aux parties moyeu et support (110, 114) de manière que la surface d'étanchéité (118) épouse la surface de portée (120) lorsque l'arbre de commande (58) se trouve à la position fermée. 10
15

5. Le pistolet à peinture selon la revendication 3 ou 4, dans lequel la soupape (60) est en polytétrafluoréthylène. 20

6. Le pistolet à peinture selon l'une des revendications précédentes, dans lequel la partie bordure extérieure (116) comprend en outre des moyens de bord avant (132) destinés à amorcer le contact entre les surfaces d'étanchéité de portée (118, 120) lorsque la soupape (60) passe en position fermée. 25

7. Le pistolet à peinture selon la revendication 6, dans lequel la partie de bordure extérieure (116) se déforme coniquement pour établir un contact entre les surfaces d'étanchéité et de portée (118, 120) qui s'adaptent, de manière qu'au moins une partie, s'y conformant, de la surface d'étanchéité prenne au conicité égale à la conicité de la surface de portée de soupape lorsque la soupape (60) est fermée. 30
35

8. Le pistolet à peinture selon la revendication 7, dans lequel la partie adaptation de forme comprend en outre une partie d'étanchéité secondaire telle que l'étanchéité aux fuites d'air est maintenue en présence d'une déformation par fluage et à froid de la partie de bordure extérieure pendant que la soupape se trouve dans la position fermée. 40
45
50
55

Fig. 2

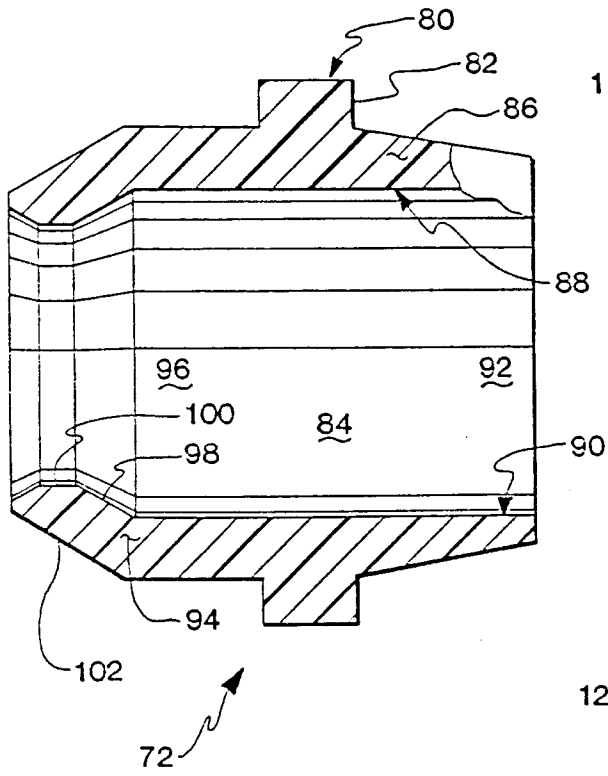
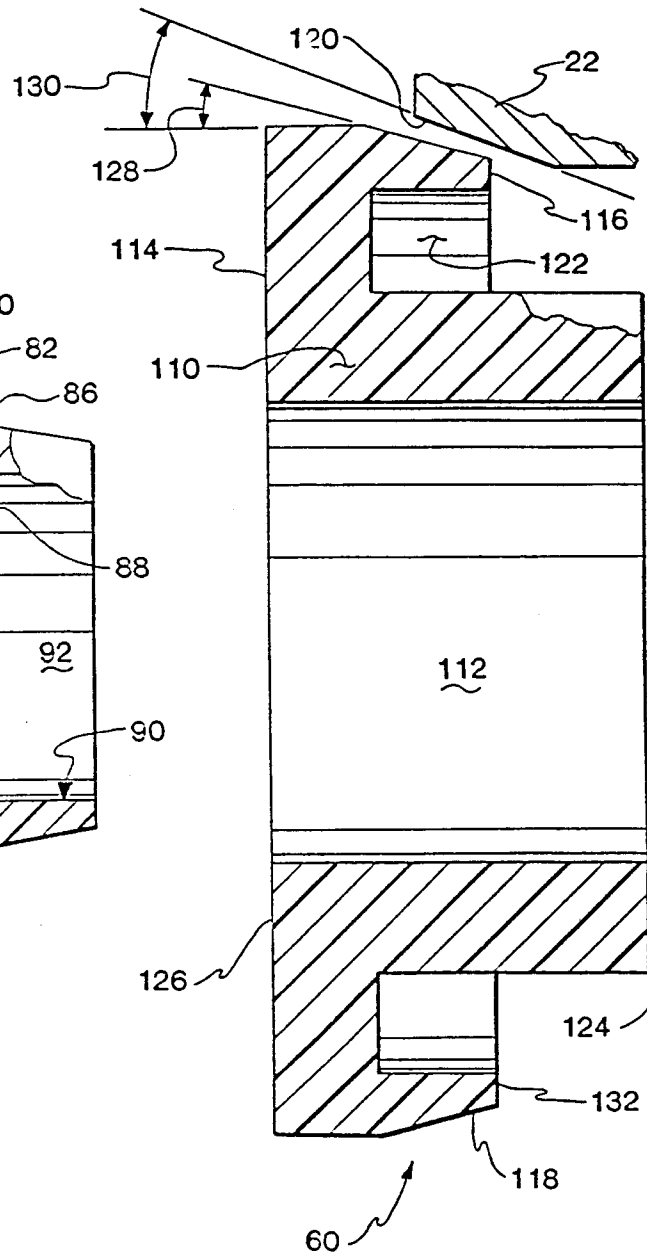

Fig. 3



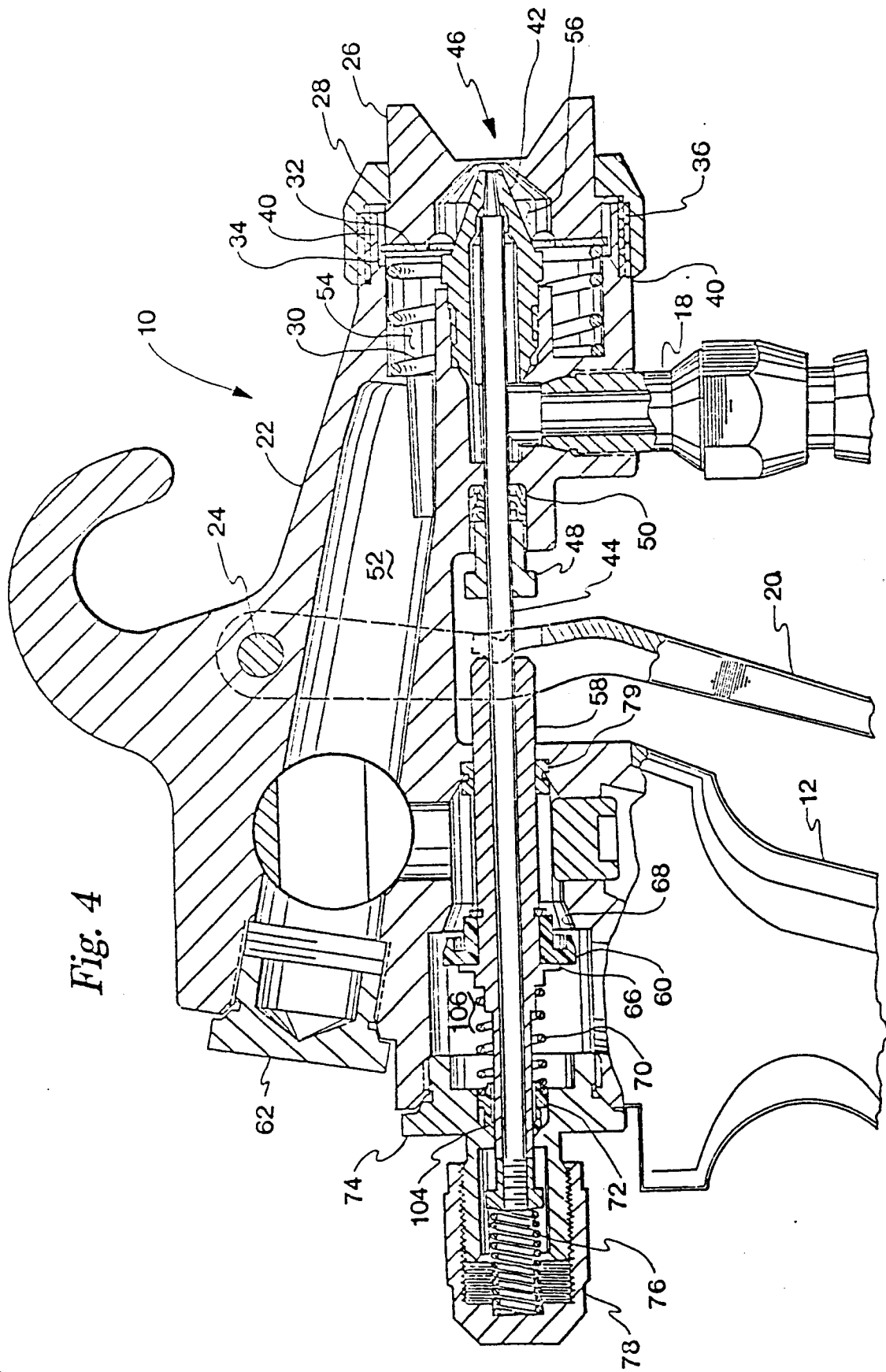

Fig. 4

