



- (51) **International Patent Classification:** Not classified
- (21) **International Application Number:**
PCT/US2012/032546
- (22) **International Filing Date:**
6 April 2012 (06.04.2012)
- (25) **Filing Language:** English
- (26) **Publication Language:** English
- (30) **Priority Data:**
61/473,102 7 April 2011 (07.04.2011) US
- (71) **Applicant (for all designated States except US):** **MOBIUS IMAGING, LLC** [US/US]; 323 West Main Street, Ayer, MA 01432 (US).
- (72) **Inventors; and**
- (75) **Inventors/Applicants (for US only):** **GREGERSON, Eugene, A.** [US/US]; c/o Mobius Imaging, LLC, 323 West Main Street, Ayer, MA 01432 (US). **CONNOR, Michael** [US/US]; c/o Mobius Imaging, LLC, 323 West Main Street, Ayer, MA 01432 (US). **ALLEN, Michael** [US/US]; c/o Mobius Imaging, LLC, 323 West Main Street, Ayer, MA 01432 (US). **SEBRING, Paul** [US/US]; C/o Mobius Imaging, Llc, 323 West Main Street, Ayer, MA 01432 (US). **POWELL, Robert** [US/US]; c/o Mobius Imaging, LLC, 323 West Main Street, Ayer, MA 01432 (US). **STANTON, Russell** [US/US]; c/o Mobius Imaging, LLC, 323 West Main Street, Ayer, MA 01432 (US). **COPPEN, Scott** [CA/US]; c/o Mobius Imaging, LLC, 323 West Main Street, Ayer, MA 01432 (US).
- (74) **Agents:** **SHAUGHNESSY, Kevin** et al.; The Marbury Law Group PLLC, 11800 Sunrise Valley Drive, 15th Floor, Reston, VA 20191 (US).
- (81) **Designated States (unless otherwise indicated, for every kind of national protection available):** AE, AG, AL, AM, AO, AT, AU, AZ, BA, BB, BG, BH, BR, BW, BY, BZ, CA, CH, CL, CN, CO, CR, CU, CZ, DE, DK, DM, DO, DZ, EC, EE, EG, ES, FI, GB, GD, GE, GH, GM, GT, HN, HR, HU, ID, IL, IN, IS, JP, KE, KG, KM, KN, KP, KR, KZ, LA, LC, LK, LR, LS, LT, LU, LY, MA, MD, ME, MG, MK, MN, MW, MX, MY, MZ, NA, NG, NI, NO, NZ, OM, PE, PG, PH, PL, PT, QA, RO, RS, RU, RW, SC, SD, SE, SG, SK, SL, SM, ST, SV, SY, TH, TJ, TM, TN, TR, TT, TZ, UA, UG, US, UZ, VC, VN, ZA, ZM, ZW.
- (84) **Designated States (unless otherwise indicated, for every kind of regional protection available):** ARIPO (BW, GH, GM, KE, LR, LS, MW, MZ, NA, RW, SD, SL, SZ, TZ, UG, ZM, ZW), Eurasian (AM, AZ, BY, KG, KZ, MD, RU, TJ, TM), European (AL, AT, BE, BG, CH, CY, CZ, DE, DK, EE, ES, FI, FR, GB, GR, HR, HU, IE, IS, IT, LT, LU, LV, MC, MK, MT, NL, NO, PL, PT, RO, RS, SE, SI, SK, SM, TR), OAPI (BF, BJ, CF, CG, CI, CM, GA, GN, GQ, GW, ML, MR, NE, SN, TD, TG).
- Published:**
— without international search report and to be republished upon receipt of that report (Rule 48.2(g))



(54) **Title:** MOBILE X-RAY IMAGING SYSTEM

(57) **Abstract:** A mobile diagnostic imaging system includes a battery system and charging system. The battery system is located in the rotating portion of the imaging system, and includes one or more battery packs, each comprising one or more electrochemical cells. Each battery pack further includes a control circuit that monitors and/or alters the state of charge of each of the electrochemical cells, and implements a control scheme that causes the electrochemical cells have a similar charge state. The charging system is located on the non-rotating portion of the system. The battery system communicates with the charging system to terminate charge when one or more of the electrochemical cells reach a full state of charge. The imaging system also includes a docking system that electrically connects the charging system to the battery system for charging of the battery system and temporarily electrically disconnects the rotating and non-rotating portions of the system during imaging. The imaging system further includes a drive mechanism for rotating the rotating portion relative to the non-rotating portion.

Mobile X-Ray Imaging System

[0001] RELATED APPLICATION

[0002] This application claims the benefit of priority to U.S. Provisional Application No. 61/473,102 entitled "Mobile X-Ray Imaging System" filed on April 7, 2011, the entire contents of which are hereby incorporated by reference for all purposes.

[0003] BACKGROUND

[0004] Conventional medical imaging devices, such as computed tomography (CT) and magnetic resonance (MR) imaging devices, are typically fixed, immobile devices located in a discrete area reserved for imaging that is often far removed from the point-of-care where the devices could be most useful.

[0005] It would be desirable to make these imaging devices mobile, so that they can move to various locations within a hospital or other health services environment. This is difficult due to the size, weight and overall number of components required for making an operable imaging system. Furthermore, these systems typically require a power system that can provide high-voltages (e.g., 120 kV) to components that rotate within the system around an imaging bore. Conventional imaging systems generally utilize a dedicated high-voltage power source and a complex power delivery mechanism, such as a slip-ring or a high-voltage cable system, to deliver the required power to the rotating imaging components. While these power systems may work fine for conventional fixed imaging systems, they are not ideal for mobile systems, which are ideally much more compact and lightweight than conventional systems. Furthermore, when transporting a mobile system outside of the traditional radiology environments, it is typically not possible to obtain the power required to perform imaging procedures from standard power outlets.

[0006] SUMMARY

[0007] Various embodiments include an imaging system that comprises a rotating portion comprising a rotor and at least one imaging component mounted to the rotor,

and a gantry comprising an outer shell that substantially fully encloses the rotating portion over one or more sides of the rotating portion, the outer shell further comprising a mounting surface for a bearing that enables the rotating portion to rotate 360° within the outer shell.

[0008] In further embodiments, a mobile diagnostic imaging system may include a battery system and charging system. The imaging system may include a first portion and a second portion, wherein the first portion rotates with respect to the second portion. In one embodiment, the rotating portion rotates within an enclosed housing of a gantry.

[0009] In embodiments, the battery system may be located in the rotating portion of the system. The battery system may include one or more battery packs, each comprising one or more electrochemical cells. Each battery pack may further include a control circuit that monitors and/or alters the state of charge of each of the electrochemical cells. The control circuit may implement a control scheme that causes the electrochemical cells to have a similar charge state. The battery system may include a communication network that allows the packs to communicate with each other in order to implement the control scheme for causing the electrochemical cells to be of similar charge state. In some embodiments, the battery packs are able to communicate with a main battery control circuit to implement the control scheme for causing the electrochemical cells to be of similar charge state.

[0010] In embodiments, the charging system may be located on the non-rotating portion of the system. The battery system may communicate with the charging system to terminate charge when one or more of the electrochemical cells reach a full state of charge. In some embodiments, the battery system communicates with a main battery control circuit to terminate charge when one or more of the electrochemical cells reach a full state of charge.

[0011] In further embodiments, the imaging system may also include a docking system that selectively couples and decouples the rotating and non-rotating portions of the system. The charging system charges the battery system when the docking system

engages to couple the rotating and non-rotating portions of the system. During an imaging scan, the docking system may temporarily electrically disconnect the rotating and non-rotating portions of the system. The battery system may provide power to the rotating portion of the system while the docking system is disengaged. In one embodiment, the charging system provides power to the non-rotating portion of the imaging system while the docking system is disengaged. Further embodiments relate to methods of docking and undocking the rotating and non-rotating components of an imaging system.

[0012] In further embodiments, the imaging system may also include a non-contact signaling system, such as an optical or magnetic system, that is provided at one or more discrete locations on both the rotating and non-rotating portions of the system. The signaling system is provided to coordinate the onset or termination of various functions within the system, such as motion or irradiation.

[0013] In further embodiments, the imaging system may include a drive mechanism for rotating the rotating portion relative to the non-rotating portion. The drive mechanism may include a belt that is provided on the non-rotating portion and a motorized system having a gear that is provided on the rotating portion. The gear meshes with the belt, so that when the gear is driven by a motor, the motorized system travels along the length of the belt, causing the rotating portion to which it is attached to rotate with respect to the non-rotating portion. The drive mechanism may be powered by the battery system.

[0014] In other embodiments, the present invention relates to methods of diagnostic imaging using an imaging system having rotating and non-rotating portions.

[0015] BRIEF DESCRIPTION OF THE DRAWINGS

[0016] Other features and advantages of the present invention will be apparent from the following detailed description of the invention, taken in conjunction with the accompanying drawings of which:

[0017] FIG. 1 is a perspective view of an X-ray CT imaging system in accordance with one embodiment of the invention.

[0018] FIG. 2A is a perspective view of a gantry and gimbal.

[0019] FIG. 2B schematically illustrates the assembly of the gimbal and gantry.

[0020] FIG. 2C shows the gimbal and gantry of FIG. 2B fully assembled.

[0021] FIG. 3A is a cross-sectional schematic illustration of an imaging system that illustrates the rotating and non-rotating portions of the system.

[0022] FIG. 3B is an exploded view of the imaging system of FIG. 3A.

[0023] FIG. 4A is an exploded view of a gantry illustrating an outer shell, a rotor and a bearing system according to one embodiment.

[0024] FIG. 4B is a perspective view of the assembled gantry.

[0025] FIG. 4C is a front elevation view of the gantry.

[0026] FIG. 4D is a side cross section view of the gantry.

[0027] FIG. 4E is a cross-section view of a portion of the gantry illustrating a bearing system in one embodiment.

[0028] FIG. 4F illustrates an arrangement of components on a rotor according to one embodiment.

[0029] FIG. 5 illustrates a battery pack control circuit according to one embodiment of the invention.

[0030] FIG. 6A is a schematic illustration of the imaging system showing the battery, charging and docking systems.

[0031] FIG. 6B schematically illustrates the power circuitry during a docking procedure of the system according to one embodiment.

[0032] FIG. 7 is a close-up view of FIG. 3A illustrating the charging system mounted on the gimbal.

[0033] FIG. 8 is a perspective view of the gimbal with charging system.

[0034] FIG. 9A is a perspective view of an embodiment of the docking system shown in a disengaged state.

[0035] FIG. 9B is a side elevation view of the docking system in a disengaged state.

[0036] FIG. 10A is a perspective view of the docking system shown in an engaged state.

[0037] FIG. 10B is a side elevation view of the docking system in an engaged state.

[0038] FIG. 11A is a perspective view of the portion of the docking system that is mounted to the rotor.

[0039] FIG. 11B is a front view of the portion of the docking system shown in FIG. 11A.

[0040] FIG. 12A is a perspective view of the portion of the docking system that is mounted to the non-rotating portion of the imaging system.

[0041] FIG. 12B is a front view of the portion of the docking system shown in FIG. 12A.

[0042] FIG. 13A is a cross-section view of an imaging system showing the location of the docking system.

[0043] FIG. 13B is a close-up view of the docking system of FIG. 13A.

[0044] FIG. 14A is a perspective view of an imaging system showing the location of the docking system.

[0045] FIG. 14B is a close-up view of the docking system of FIG. 14A.

[0046] FIG. 15 illustrates a non-contact signaling apparatus according to one embodiment.

[0047] FIG. 16 is a cross-section view of an imaging system with a drive mechanism for driving the rotation of the rotor.

[0048] FIG. 17 is a perspective view of the imaging system illustrating the rotor drive mechanism.

[0049] FIG. 18 is a magnified view of the rotor drive mechanism of FIG. 17.

[0050] FIG. 19 is a perspective view of the drive mechanism showing a belt and motorized gear system.

[0051] DETAILED DESCRIPTION

[0052] The various embodiments will be described in detail with reference to the accompanying drawings. Wherever possible, the same reference numbers will be used throughout the drawings to refer to the same or like parts. References made to particular examples and implementations are for illustrative purposes, and are not intended to limit the scope of the invention or the claims.

[0053] This application claims the benefit of priority to U.S. Provisional Application No. 61/473,102 entitled "Mobile X-Ray Imaging System" filed on April 7, 2011. This application is also related to U.S. Application No. 12/576,681, filed October 9, 2009, now U.S. Patent No. 8,118,488, U.S. Application No. 13/025,566, filed February 11, 2011, and U.S. Application No. 13/025,573, filed February 11, 2011. The entire contents of all of these applications are hereby incorporated by reference for all purposes.

[0054] Referring to FIG. 1, a mobile imaging system 100 according to one embodiment of the invention includes a mobile base 20, a gimbal 30, a gantry 40, and a pedestal 50. The system 100 includes image collection components, such as a rotatable x-ray source and detector array or stationary magnetic resonance imaging components, that are housed within the gantry 40. The system 100 is configured to

collect imaging data, such as, for example x-ray computed tomography (CT) or magnetic resonance imaging (MRI) data, from an object located within the bore of the gantry 40, in any manner known in the medical imaging field. The pedestal 50 is adapted to support a tabletop support 60 that can be attached to the pedestal 50 in a cantilevered manner and extend out into the bore of the gantry 40 to support a patient or other object being imaged.

[0055] The gantry 40 and gimbal 30 are illustrated in FIG. 2A. The gimbal 30 is a generally C-shaped support that is mounted to the top surface of base 20 and includes a pair of arms 31, 33 extending up from the base. The arms 31, 33 are connected to opposite sides of gantry 40 so that the gantry is suspended above base 20 and gimbal 30. In one embodiment, the gimbal 30 and gantry 40 can rotate together about a first axis (a) relative to the base 20, and the gantry 40 can tilt about a second axis (a') relative to the gimbal 30 and base 20.

[0056] In certain embodiments, the gimbal 30 and gantry 40 can translate with respect to the base 20 to provide an imaging scan. The gimbal 30 can include bearing surfaces that travel on rails 23, as shown in FIG. 1, to provide the translation motion of the gimbal 30 and gantry 20. A scan drive mechanism can drive the translation of the gantry and gimbal relative to the base, and a main drive mechanism can drive the entire system in a transport mode. In the embodiment of FIG. 1, both of these functions are combined in a drive system 70 that is located beneath the gimbal 30.

[0057] In certain embodiments, the base 20 of the system can be omitted, and the gimbal 30 can sit directly on the ground to support the gantry 40. In other embodiments, the gimbal can be omitted, and the gantry 40 is a stand-alone gantry that sits on the ground.

[0058] FIG. 2B is an exploded view of the gimbal 30, illustrating how the gimbal 30 may be connected to the gantry 40 in various embodiments. As shown in FIG. 2B, the gimbal 30 may be assembled from multiple pieces. Upper portions 201, 203 of the gimbal 30 may be securely fastened to opposing sides of the gantry 40. The upper portions 201, 203, which may have a shape similar to "earmuffs," may include a

bearing apparatus that enables the “tilt” motion of the gantry 40 relative to the gimbal 30. The upper portions 201, 203 may also be fastened to the respective arms 31, 33 of the gimbal 30. For ease of assembly, it may be preferable to fasten the upper portions 201, 203 to the gantry 40 before connecting the entire gantry/upper portion assembly to the respective arms 31, 33 of the gimbal 30. Also shown in FIG. 2B is a cover 205 that may be placed over an access opening in one or both arms 31, 33 of the gimbal 30. An additional cover 207 may be provided over the base of the gimbal 30, and may be removed to access a bearing and/or drive system positioned within or beneath the base of the gimbal 30.

[0059] FIG. 3A is a cross-sectional view of the gantry 40 and gimbal 30 that illustrates a number of components of the imaging system 100, which in this embodiment comprises an X-ray CT imaging system, including an x-ray source 43, high-voltage generator 44, x-ray detector 45, battery system 63, computer 46, rotor drive mechanism 47, docking system 35 and charging system 34. A number of these components, including the x-ray source 43, high-voltage generator 44, x-ray detector 45, battery system 63, computer 46 and rotor drive mechanism 47, are mounted on a rotor 41, as is illustrated in the exploded view of FIG 3B. The rotor 41 and the components mounted thereto, rotate within a housing defined by an outer shell 42 of the gantry 40.

[0060] The system 100 thus has a rotating portion 101, which includes the rotor 41 and the various components mounted to the rotor that rotate within the gantry 40 during an imaging scan, and a non-rotating portion 103, that generally includes the other components of the system, including the base 20, gimbal 30, and the outer shell 42 of the gantry 40. The charging system 34 is located on the non-rotating portion 103 of the system. The docking system 35 provides intermittent connection between the rotating and non-rotating portions 101, 103 for transfer of power and/or data between the two portions.

[0061] During an imaging scan, the rotor 41 rotates within the interior of the gantry, while the imaging components such as the x-ray source 43 and x-ray detector 45

obtain imaging data for an object positioned within the bore of the gantry, as is known, for example, in conventional X-ray CT scanners. The rotor drive mechanism 47 drives the rotation of the rotor 41 around the interior of the gantry 40. The rotor drive mechanism 47 may be controlled by a system controller that controls the rotation and precise angular position of the rotor 41 with respect to the gantry 40, preferably using position feedback data, such as from a position encoder device.

[0062] Various embodiments of the imaging system 100 may be relatively compact, which may be desirable, for example, in a mobile imaging system. One way in which the system 100 may be made compact is in the design of the gantry 40 and its interface with the rotating portion 101 (e.g., the rotor 41 and the various components mounted to the rotor 41). In embodiments, the outer shell 42 of the gantry 40 may comprise both a protective outer covering for the rotating portion 101 and a mounting surface for a bearing that enables the rotating portion 101 to rotate 360° within the outer shell 42 of the gantry 40.

[0063] FIG. 4A is an exploded view of a gantry 40 according to one embodiment that illustrates the outer shell 42, the rotor 41 and a bearing assembly 400. Fig. 4B illustrates the assembled gantry 40. As is shown in FIGS. 4A-B, the outer shell 42 of the gantry 40 may be a generally O-shaped covering of a structural material that may at least substantially fully enclose the rotating portion 101, including the rotor 41 and any components mounted to the rotor, over one or more sides of the rotating portion 101. The outer shell 42 of the gantry 40 may be conceptually considered an “exoskeleton,” that both supports the rotating portion 101 of the system 100, preferably in three dimensions, and also provides a protective barrier between the rotating portion 101 and the external environment. In embodiments, the outer shell 42 of the gantry 40 may support at least about 75%, such as more than 80%, and preferably more than about 90%, such as more than 99%, and even more preferably 100% of the weight of the rotating portion 101 of the imaging system 100. In embodiments, the outer shell 42 itself may be supported by one or more other components, such as a gimbal 30, base 20 and/or drive mechanism 70, as shown in FIG. 1, for example. In other embodiments, the outer shell 42 may be supported

directly on the ground, for example, or via other means, such as raised on a pedestal, table, cart or other support, or suspended or cantilevered from a wall, ceiling or other support structure. In certain embodiments, an outer shell 42 of the gantry 40 that comprises both a protective outer covering for the rotating portion 101 and a mounting surface for a bearing for rotation of the rotating portion 101 may provide the gantry 40 with various degrees-of-freedom, such as the “tilt” motion about axis (a') and/or rotation about axis (a) as shown in FIG. 2A, as well as translation motion for imaging applications and/or transport of the gantry 40.

[0064] The outer shell 42 may be fabricated from a sufficiently rigid and strong structural material, which may include, for example, metal, composite material, high-strength plastic, carbon fiber and combinations of such materials. In preferred embodiments, the outer shell 42 may be comprised of a metal, such as aluminum. The outer shell 42 may be machined or otherwise fabricated to relatively tight tolerances. The outer shell 42 may be formed as a one piece, unitary component. In other embodiments, the outer shell 42 may be comprised of multiple components and/or materials that may be joined using any suitable technique to provide the shell 42.

[0065] The outer shell 42 may have an outer circumferential surface 406 that may extend around the the periphery of the rotating portion 101 of the system 100 to substantially fully enclose the rotating portion 101 around its outer circumference. As used herein, “substantially fully enclose” means that the circumferential surface 406 encloses at least about 60%, such as at least about 70% (e.g., 75% or more), and preferably at least about 80%, such as at least about 90% (e.g., between 95% and 100%) of the rotating portion 101 around its outer circumference. As shown in FIG. 4B, for example, the outer shell 42 may substantially fully enclose the rotating portion while also including one or more openings, such as opening 408 (where the gantry 40 is secured to the gimbal 30) and access opening 410.

[0066] The outer shell 42 may also include at least one side wall 412 that may extend from the outer circumferential surface 406 to a bore 416 of the gantry 40 and may substantially fully enclose the rotating portion 101 around one side of the rotating

portion. In embodiments, the outer shell 42 may include two side walls, one on each side (e.g., front and rear) of the gantry 40, and the two side walls may substantially fully enclose the rotating portion 101 around two sides of the rotating portion. In the embodiment shown in FIGS. 4A-F the outer shell 42 includes a side wall 412 on a first side (e.g., the front side) of the gantry 40. As shown in FIGS. 4C-E, an opposite (e.g., rear) side wall 414 of the gantry 40 may be formed by the combination of the outer shell 42, bearing assembly 400, and/or the rear surface of the rotor 41. The side wall 414 may substantially fully enclose the various components mounted to the rotor 41 around a side of these components. The outer circumferential wall 406 and the side walls 412 and 414 may define a cavity 418, as shown in FIG. 4E, and the various components mounted to the rotor 41 may rotate within the cavity 418. A protective outer covering may be provided over the rear side wall 414 and/or over the interior circumference of the gantry 40 (e.g., around the outer circumference of the bore 416) to provide an additional barrier between the rotating portion 101 and the external environment. The protective covering may be comprised of a thin, lightweight material, such as plastic.

[0067] As will be discussed in further detail below, the drive mechanism for the rotating portion 101 of the imaging system may utilize a belt drive on the rotor 41, where the belt for the drive is mounted to a fixed railing 81, as is shown in FIG. 4F. In various embodiments, a railing 81 or similar fixed structure for the rotor drive 41 may be located on the internal surface of side wall 412.

[0068] The bearing assembly 400 according to one embodiment is shown in FIGS. 4A and 4E. In this embodiment, the bearing assembly 400 includes a first race 402 that may be securely fastened to the outer shell 42 of the gantry 40, and a second race 404 that may be securely fastened to the rotor 41. A bearing element 406 (FIG. 4E) is provided between the first race 402 and the second race 404, and is configured to allow the second race 404 (along with the rotor 41 to which it is attached) to rotate concentrically within the first race 402, preferably with minimal friction, thereby enabling the rotor 41 to rotate with respect to the outer shell 42 of the gantry 40. In the exemplary embodiment of FIG. 4E, the bearing assembly 400 may abut against a

lip 424 in the rotor, and a plurality of fastening members 426 (such as bolts) may be provided through the lip 424 and into the second race 404 around the periphery of the rotor 41 to securely fasten the rotor 41 to the bearing assembly 400. The bearing assembly 400 may also be provided at least partially within the outer circumferential wall 406 of the outer shell 42 and against a lip 422 in the outer shell 42 of the gantry 40. A plurality of fastening members (similar to fastening members 426) may be provided through the lip 422 and into the first race 402 around the periphery of the outer shell 42 to securely fasten the outer shell 42 to the bearing assembly 400. A small gap 428 may be provided between lip 422 and lip 424. In some embodiments, all or a portion of the bearing assembly 400 may be integrally formed as a part of the outer shell 42 or of the rotor 41, or of both. For example, the first race 402 may be formed as an integral surface of the outer shell 42 and/or the second race 404 may be formed as an integral surface of the rotor 41. In various embodiments, the entire bearing assembly for enabling the rotation of the rotating portion 101 with respect to the non-rotating portion 103 of the imaging system 100 may be located within the generally O-shaped gantry 40.

[0069] The outer diameter of the gantry 40 can be relatively small, which may facilitate the portability of the system 100. In a preferred embodiment, the outer diameter (OD in FIG. 4C) of the gantry 40 is less than about 70 inches, such as between about 60 and 68 inches, and in one embodiment is about 66 inches. The outer circumferential wall 406 of the outer shell 42 may be relatively thin to minimize the OD dimension of the gantry 40. In addition, the interior diameter of the gantry 40, or equivalently the bore 416 diameter (ID in FIG. 4C), can be sufficiently large to allow for the widest variety of imaging applications, including enabling different patient support tables to fit inside the bore, and to maximize access to a subject located inside the bore. In one embodiment, the bore diameter of the gantry 40 is greater than about 38 inches, such as between about 38 and 44 inches, and in some embodiments can be between about 40 and 50 inches. In one exemplary embodiment, the bore has a diameter of about 42 inches. As shown in FIG. 4D, the gantry 40 generally has a narrow profile, which may facilitate portability of the system 100. In

one embodiment, the width of the gantry 40 (W) is less than about 17 inches, and can be about 15 inches or less.

[0070] A number of features of the various embodiments may facilitate the compact size of the imaging gantry 40. For example, as previously discussed the outer shell 42 of the gantry 40 may be a relatively thin yet rigid exoskeleton structure that provides a protective outer covering for the rotating components while simultaneously supporting the rotating components in multiple dimensions as they rotate relative to the outer shell 42. Various additional features are illustrated in FIG. 4F, which illustrates the rotating portion 101 of the imaging system 100 according to one embodiment. The various components, such as x-ray source 43, detector 45, high-voltage generator 44, heat exchanger 430, computer 46, battery system 63, docking system 35 and rotor driver 47, may be mounted to rotor 41 and configured to fit and rotate within the internal cavity 418 of the gantry 40 shown in FIG. 4E. As shown in FIGS. 3A and 4F, for example, this may include providing the drive mechanism 47 within the interior cavity 418 of the gantry 40, which may aid in minimizing the outer diameter and width dimensions of the gantry 40 while also enabling a relatively large bore diameter. Various other components may be configured to facilitate a compact gantry design. For example, as shown in FIG. 4F, the high-voltage generator 44, which may be one of the larger components of the rotating portion 101, may have at least one surface 432, 434 that is angled or curved to substantially correspond with the curvature of the gantry 40 and/or bore 416. Another example of a high-voltage generator 44 with an angled or curved outer surface is shown in FIGS. 3A-B. Similarly, the battery system 63 may be housed in a chassis having at least one surface 436, 436 that is angled or curved to substantially correspond with the curvature of the gantry 40 and/or bore 416. In this way, the outer diameter of the gantry may be minimized while also maintaining a relatively large bore diameter.

[0071] The imaging system 100 generally operates in a conventional manner to obtain images of an object located in the bore of the gantry. For example, in the case of an x-ray CT scan, the rotor 41 rotates within the housing of the gantry 40 while the imaging components, including the x-ray source and x-ray detector, obtain image data at a

variety of scan angles. Generally, the system obtains image data over relatively short intervals, with a typical scan lasting less than a minute, or sometimes just a few seconds. During these short intervals, however, a number of components, such as the x-ray source tube and the high-voltage generator, require a large amount of power, including, in some embodiments, up to 32 kW of power.

[0072] In one embodiment, the power for the rotating portion 101 of the system 100 is provided by a battery system 63 that is located on the rotating portion 101 of the system 100. An advantage of the battery-based power supply is that the conventional schemes for delivering power to the imaging components, such as complicated and expensive slip-ring systems and bulky cable systems, can be avoided.

[0073] As shown in FIGS. 3A and 3B, the battery system 63 is mounted to and rotates with the rotor 41. The battery system 63 includes a plurality of electrochemical cells. The cells can be incorporated into one or more battery packs. In one embodiment, for example, the battery system 63 includes seven battery packs 64, with sixty-four cells per pack 64, for a total of 448 cells. The battery system 63 is preferably rechargeable, and is recharged by the charging system 34 when the rotor 41 is not rotating. In one embodiment, the battery system 63 consists of lithium iron phosphate (LiFePO_4) cells, though it will be understood that other suitable types of batteries can be utilized.

[0074] The battery system 63 provides power to various components of the imaging system 100. In particular, since the battery system 63 is located on the rotating portion 101 of the imaging system 100, the battery system 63 can provide power to any component on the rotating portion 101, even as these components are rotating with respect to the non-rotating portion 103 of the imaging system 100. Specifically, the battery system 63 is configured to provide the high voltages and peak power required by the generator 45 and x-ray tube 43 to perform an x-ray imaging scan. For example, a battery system may output ~360V or more, which may be stepped up to 120kV at a high-voltage generator (which may also be located on the rotating portion 101) to perform an imaging scan. In addition, the battery system 63 can provide

power to operate other components, such as an on-board computer 46, the detector array 45, and the drive mechanism 47 for rotating the rotor 41 within the gantry 40.

[0075] Each of the battery packs 64 includes an associated control circuit 66, which can be provided on a circuit board. In certain embodiments, the control circuits 66 can communicate with one another and/or with a main battery controller that is also located on the rotating portion 101 of the imaging system 100.

[0076] The battery pack control circuit(s) 66 are configured to monitor and/or alter the state of charge of each of the electrochemical cells 65 in the battery pack 64. An example of a battery pack control circuit 66 is shown in FIG. 5. In this embodiment, the control circuit 66 connects across each individual cell 65. The control circuit 66 monitors the voltage of the cell 65, and generates signals from the analog-to-digital converter 71 that indicate the charge-state of the cell. These signals are provided to the main battery controller 67, which monitors the charge-state of all the cells in the battery system. The controller 67 may comprise a processor having an associated memory that may execute instructions (e.g. software) stored in the memory. The main battery controller 67 can send control signals to the respective control circuits 66 to alter the state of charge of each electrochemical cell 65. In the embodiment of FIG. 5, the main battery controller 67 alters the charge-state of the cell 65 by switching on transistor 72, which connects the cell 65 across load resistor 73. The cell 65 can then be partially drained in a controlled manner. The battery controller 67 can continue to monitor the charge state of the cell 65 and switch off the transistor 72 when the cell 65 reaches a pre-determined charge state. In one embodiment, whenever the cell 65 is in danger of overcharging, the load resistor is switched in until the battery is at a safe charge state. In certain embodiments, if an overcharge condition is actually reached in one or more cells, the charging system can be switched off while the load resistor continues to drain the cell. Other cell charging and balancing schemes can also be employed.

[0077] In certain embodiments, the battery system includes processing circuitry that is configured to implement a control scheme to cause the electrochemical cells to have

substantially the same charge state. This control scheme can be implemented by a main battery controller 67, for example, or can be implemented by the plurality of battery pack control circuits 66 in communication with each another. In one exemplary embodiment of the control scheme for the battery system, a load resistor is switched in for each cell when the cell either exceeds the desired charge voltage or when the cell exceeds the average cell voltage by a pre-determined threshold. The charging system is disabled if any cell exceeds the maximum charging voltage.

[0078] FIG. 6A schematically illustrates the battery system 63, charging system 34 and docking system 35 according to one embodiment. The charging system 34 provides electrical power to the battery system 63 in order to charge the rechargeable electrochemical cells. In a preferred embodiment, the charging system 34 is located on the non-rotating portion 103 of the imaging system 100. For example, the charging system 103 can be located on the gimbal 30, the outer shell 42 of the gantry 40, the base 20 or the pedestal 50 (see, e.g., FIGS. 1-3B). In a preferred embodiment, the charging system 34 is located on the gimbal 30. FIGS. 3A, 7 and 8 illustrate one embodiment of a charging system 34 that is located on the gimbal 30. The charging system 34 is electrically coupled to the battery system 63 at least during the times when the rotating portion 101 of the imaging system 100 is stationary relative to the non-rotating portion 103, such as in between imaging scans. The charging system 100 need not be, and in preferred embodiments is not, electrically coupled to the rotating portion 101 during an imaging scan. In one embodiment, the docking system 35 couples the charging system 34 to the battery system 63 when the rotating portion 101 is in a stationary or “park” mode, as is described in greater detail below.

[0079] The charging system 34 is configured to receive input power from an external power source, such as a standard wall power outlet. The charging system 34 can include circuitry that conditions the input power to render it suitable for recharging the battery packs 64 on the rotor 41. The charging system 34 can also include control circuitry that communicates with the battery pack control circuit(s) and controls the operation of the charging system.

[0080] In one embodiment, the charging system 34 is configured to automatically begin charging of the battery system 63 when the charging system 34 is electrically coupled to the battery system 63. During the charging operation, the battery pack control circuits 66 and/or the main battery controller 67 monitor the state of charge of the individual cells 65, and can instruct the charging system 34 to terminate charging when a pre-determined charge-state is reached. For example, charging can terminate when one or more of the electrochemical cells 65 reach a full state of charge.

[0081] The docking system 35 is configured to selectively couple and de-couple the rotating 101 and non-rotating 103 portions of the imaging system 100. As schematically illustrated in FIG. 6A, a first portion 36a of the docking system 35 is located on the rotating portion 101 of the system, preferably on the rotor 41, and includes a mating surface that faces towards the outer circumference of the gantry 40. A second portion 36b of the docking system 35 is located on the non-rotating portion 103 of the system, such as on the gimbal 30, and includes a mating surface that faces into the interior housing of the gantry. When the system is in “park” mode, the rotor 41 automatically rotates to a position where the first 36a and second 36b portions of the docking system 35 are aligned and facing one another. Mating features (e.g., pin(s) and socket(s)) on one or both of the first 36a and second 36b portions of the docking system are actuated to physically connect the two portions 36a, 36b. During an imaging scan, the two portions 36a, 36b disengage from each other, and the first portion 36a rotates with the rotor 41 inside the interior housing of the gantry 40.

[0082] The docking system 35 includes at least one electrical connection for providing power to components on the rotating portion 101, including the rechargeable battery system 63. When the docking system 35 is disengaged, such as during an imaging scan, power for the components of the rotating portion 101 comes from the battery system 63. Components on the non-rotating portion 103 of the imaging system 100 can remain powered by an external power source, such as grid power.

[0083] In one embodiment, the docking system 35 further includes at least one electrical connection for data transfer between the rotating and non-rotating portions

of the imaging system 100. The rotating portion 101 of the imaging system 100 obtains imaging data at the detector array 45, and this data may be transferred off the rotating portion 101 via the docking system 35 for processing and/or display. In one embodiment, the rotating portion 101 of the imaging system 100 includes a computer 46 having a memory and processor. The image data obtained at the detector 45 may be sent to the computer 46 for temporary storage and optional processing while the rotating portion 101 is rotating. Following an image scan, the rotating and non-rotating portions of the system are connected by the docking system 35, and the data from the on-board computer 46 may be downloaded off the rotating portion 101 for further processing and/or display.

[0084] An embodiment of a docking system 35 is shown in FIGS. 9A-14B. The first portion 36a of the docking system 35 includes a pair of moveable rods 51 that reciprocate between a first, disengaged position (FIGS. 9A and 9B) and a second, engaged position (FIGS. 10A and 10B). The first portion 36a is shown in FIGS. 11A and 11B. An electrical connector 53a is secured between the rods 51 and moves with the movement of the rods. An actuator, which in this embodiment includes a motor 55 and lead screw 56, drives the movement of the rods 51 and connector 53a. The second portion 36b of the docking system 35 is illustrated in FIGS. 12A and 12B, which shows a pair of slots 52 and an electrical connector 53b that is configured to mate with the connector 53a on the first portion 36a. During engagement of the docking system 35, the rods 51 from the first portion 36a move into engagement with the corresponding slots 52 in the second portion 36b of the docking system. This engagement prevents the rotating portion 101 from moving relative to the non-rotating portion 103 while the docking system is engaged. The rods 51 and slots 52 also ensure that the respective electrical connectors 53a, 53b on the first and second portions 36a, 36b are properly aligned as the actuator mechanism 55, 56 moves the connectors 53a, 53b into mating engagement. When the docking system 35 is engaged (FIGS. 10A and 10B), the connectors 53a, 53b carry electrical power to charge the battery system, and also enable data and control signals to pass between the rotating and non-rotating portions of the system.

[0085] FIGS. 13A-14B illustrate the location of the docking system 35 within the imaging system 100. As seen most clearly in Fig. 13B, the first portion 36a is mounted to and rotates with the rotor 41. Between scans, the rotor 41 rotates to the “park” position of FIG. 13, and the docking system 35 is engaged. The second portion 36b of the docking system 35 is located on the gimbal 30, as shown in Figs. 14A-B. In a preferred embodiment, the second portion 36b is mounted to the bearing on the gimbal that allows the gantry to tilt with respect to the gimbal, such that the second portion 36b rotates with the tilting motion of the gantry, which allows the docking system to dock and undock while the gantry is tilted.

[0086] In one embodiment of a docking sequence, the control circuitry on the rotor 41 causes the rotor drive mechanism 47 to rotate the rotor to the “park” position, preliminary to docking. Then, the control circuitry causes the actuator mechanism 55, 56 to drive the rods 51 (fast) to the point where the tapered end portions of the rods 51 (see, e.g., FIGS. 9A-B) engage with “rollers” that define the slots 52 on the second portion 36b of the docking mechanism. Then, the control parameters of the rotor drive mechanism are relaxed such that it can be back driven. The mating electrical contacts are then prepared to engage such that they are protected from damage during docking, as is discussed further below. Next, the rods 51 are driven (slow) to the “docked” position whereby the tapered portion of the rods pushes the rotor into alignment through contacting the rollers on the mating dock. The control circuitry then reads a loopback signal on the dock to determine proper engagement, and once proper engagement is determined, the electrical connections (e.g., power and data connections) between the rotating 101 and non-rotating 103 portions of the system are engaged. Rotor drive control parameters are then restored, and the position is assigned within the control software.

[0087] FIG. 6B is a schematic illustration of the system power circuitry during a docking procedure, according to one embodiment. The system is shown in a docked configuration, with the components on the non-rotating portion 103, including charger 34 and one or more device(s) 97, which branch off a main power bus 99, electrically connected to the components on the rotating portion 101, including battery 63 and one

or more device(s) 98, via docking system 35. To un-dock the system, the electrical connection between the rotating 101 and non-rotating 103 components must be broken. However, at the voltages and currents used by the system, as the respective contacts physically separate, the electricity will continue to flow briefly across the gap, forming a spark. This spark tarnishes and erodes the contacts over time, and in some cases can weld the contacts together.

[0088] There is a similar problem when the system re-docks. If the voltages on each side of the docking system are significantly different, large currents may flow through the dock as the two sides of the power system equalize. These currents can overheat the contacts.

[0089] In one embodiment, both of these problems are solved by designing and operating the system so that the voltage on the non-rotating 103 (charger) side is higher than the voltage on the rotating 101 (battery) side whenever the dock is being mated or unmated. That guarantees that current can only flow in one direction through the dock. Then, before the mating or unmating procedure is performed, a switch 93, which can be a solid-state relay (SSR), is opened to prevent current flow in that direction (i.e. from the non-rotating to the rotating side). The docking system 35 can then be safely docked or undocked.

[0090] An inrush current limiting circuit 94, which can comprise an NTC resistor, for example, is provided in series with the relay 93 to protect components, including the relay(s) and the docking system 35, against damage from current inrush during a docking procedure when the relay 93 is turned on.

[0091] Note that when the system is docked, power is always free to flow from the batteries 63 to components on the non-rotating side 103 of the system via diode 92 and docking system 35. However, the rotating portion 101 cannot receive power from the non-rotating portion unless the relay 93 is switched on. The relay 93 can also be used to halt charging of the batteries in an over-charge or other emergency situation.

[0092] In practice, this configuration means that the system generally cannot be undocked while it is not plugged into the wall (i.e., the entire system is being run off the batteries) or when the main/transport drive for the system is active because this component can draw more power than the charger can source. However, neither of these cases is particularly restrictive within normal use of the system.

[0093] The systems can include additional safety/failsafe features, such as relays 95, 95 to protect the various device component(s) 97, 98 on both the non-rotating and rotating sides 103, 101 of the system. For example, in the case where the non-rotating portion 103 loses power during a scan (i.e. with the system un-docked), the system can be configured so that all the relays 95 on the non-rotating portion 103 automatically turn off, so that the non-rotating portion 103 is essentially electrically inert when, after the scan, the rotating portion 101 re-docks. Similar relays 96 can be provided on the rotating portion 101, for example, to selectively turn off components 98.

[0094] In certain embodiments, data transfer between the rotating 101 and non-rotating 103 portions of the imaging system 100 can be accomplished using a slip ring system. With the slip ring system, continuous electrical contact is maintained between the stationary and rotating parts of the imaging system 100. In one embodiment, a conductive ring is positioned on the outer circumference of the rotating portion 101 and electrical contacts, such as conductive brush(es), are located on the non-rotating portion 103 and maintain continuous contact with the rotating portion 101 during imaging. During an imaging scan, data is transferred from the rotating to the non-rotating portions via the slip ring in real-time. Power to the rotating portion 101 can be provided through the docking system 35 to the rechargeable battery system 63, as described above. The slip ring system can therefore be optimized for high-speed data transfer. The slip ring system in this embodiment need not be designed for high-voltage, high-power operation, which can help minimize the complexity and expense of the slip ring system. In an alternative embodiment, a cable system can be used for data transfer between the rotating and non-rotating portions. As with the slip ring embodiment, the cable system need not be designed for high-voltage, high-power

operation, since primary power to the rotating portion is provided by the rechargeable battery system.

[0095] In another alternative embodiment, the rotating portion 101 can include a wireless transmitter for transmitting the data off of the rotating portion 101 via a wireless communication link. In this embodiment, the image data need not be transferred over the docking system 35 or a slip-ring or cable system.

[0096] The docking system 35 may also be used to transmit control signals between the rotating and non-rotating portions of the imaging system 100. The control signals can include, for example, signals from a main system controller 27 (FIG. 6A), located on the non-rotating portion 103 to components on the rotating portion 101, such as the x-ray source and detector, battery system and on-board computer, as well as signals from the rotating portion to the non-rotating portion, such as signals from the battery system 63 to the charging system 34 with respect to the charge state of the electrochemical cells. It will be understood that these signals can also be sent over a slip ring or cable system or by a wireless link, as described above.

[0097] As previously discussed, an advantage of the battery-based power supply of the invention is that the conventional schemes for delivering power to the imaging components, such as complicated and expensive slip-ring systems and bulky cable systems, can be avoided. In one embodiment, during an imaging scan the imaging system 100 is essentially severed in two, with two independent sub-systems (i.e., the rotating and non-rotating portions) operating independently of one another. This is different from conventional imaging systems, in which the rotating components remain physically coupled to the non-rotating portion of the system, via a cable or slip-ring or the like.

[0098] In one embodiment, as shown in FIG. 15, the present invention includes a non-contact signaling apparatus 74 located at discrete positions on the rotating and non-rotating portions of the imaging system. The signaling apparatus 74 allows for minimal communication between the rotating and non-rotating portions of the imaging system. In one aspect, the signaling apparatus 74 functions as a safety mechanism.

For example, during an imaging scan, the signaling apparatus 74 on the non-rotating portion 103 communicates a signal to the rotating portion 101, instructing the rotating portion 101 to continue the scan. This periodic signaling from the non-rotating portion to the rotating portion enables the scan to continue. However, if for any reason the scan needs to be terminated (such as due to a loss of power or because of a patient or clinician safety issue), the signaling apparatus 74 ceases communication of these “enable scan” signals. This lack of a signal causes the rotating component to immediately terminate the scan, without having to wait for the rotating portion to fully complete the scan and return to the docking position.

[0099] The signaling apparatus 74 can also be used to provide a signal from the rotating to the non-rotating portions to continue the scan. For example, if there is a malfunction on the rotating portion of the system (e.g., the x-ray generator fails to produce radiation, the rotor fails to rotate properly, etc.), it does not make sense for the non-rotating components to continue with the scan. In this embodiment, the scan is automatically terminated when the rotating portion stops sending signals to the non-rotating portion via the signaling apparatus 74.

[00100] In some embodiments, the signaling apparatus 74 may be used to transmit synchronization information from the rotating portion 101 to the non-rotating portion 103 of the imaging system. For example, a signaling apparatus 74 on the rotating portion 101 may communicate a signal to the non-rotating portion 103 to assist in coordinating various functions between the two portions. In one example, the signaling apparatus 74 may be used to coordinate a z-axis translation of the gantry 40 relative to the patient with the rotational motion of the rotor 41. Since the two halves of the imaging system become physically disconnected during a scan, this allows for the two halves to coordinate when they are going to start a scan sequence. A typical sequence is for the docking system to disconnect, the rotor to start accelerating, and then a signal is sent from the rotating portion to the non-rotating portion via the signaling apparatus 74 to trigger the start of the z-axis translation.

[00101] The non-contact signaling apparatus 74 may use, for example, optical or magnetic signals. One embodiment of the signaling apparatus 74 is schematically illustrated in FIG. 15. In this embodiment, the non-contact signaling apparatus 74 employs optical signaling, and includes light-emitting diodes (LEDs) 75 and photo-detectors 76 at discrete positions on the rotating 101 and non-rotating 103 portions of the imaging system. Two sets of signaling devices, each set consisting of an LED 75 and a photo-detector 76, are located on the non-rotating portion 103 of the imaging system 100, such as on the gantry 40 or the gimbal 30. Two additional sets of signaling devices, each also consisting of an LED 75 and photo-detector 76, are located on the rotating portion 101 of the imaging system 100, and in particular, on the rotor 41. The two sets of signaling devices on the non-rotating portion 103 are on opposite sides of the gantry 40; i.e., separated by 180 degrees. The two sets on the rotating portion 101 are separated by 90 degrees. In this way, the rotating 101 and non-rotating 103 portions of the imaging system 100 may exchange signals with one another at every 90 degrees of rotation of the rotating portion 101.

[00102] According to another aspect, the imaging system 100 includes a rotor drive mechanism 47, as shown in FIGS. 3A, 3B and 4F, which drives the rotation of the rotating portion 101 relative to the non-rotating portion 103. One embodiment of the rotor drive mechanism 47 is illustrated in FIGS. 16-19. In this embodiment, the rotor 41 is driven by an internal belt drive. The belt 82 extends around the outer circumference of a circular railing 81. The railing 81 (which can be seen in the exploded view of FIG. 3B and in FIG. 4F) is mounted to an interior wall of the outer shell 42 of the gantry 40. The drive mechanism 47 includes a motor 83, gear 84 and rollers 85, and is mounted to the rotor 41. The belt 82 is looped through the drive mechanism 47, running between each of the rollers 85 and the railing 81, and over the gear 84, as is most clearly illustrated in FIGS. 18 and 19. (When viewed from the side, the path of the belt 82 through the drive mechanism 47 somewhat resembles the Greek letter omega, Ω). The gear 84 is driven by the motor 83. As the gear 84 rotates, it meshes with the belt 82, which is held against the railing 81 by the rollers 85. The rotation of the gear 84 causes the drive mechanism 47 to “ride” along the

length of the belt 81, thus driving the rotation of the rotor 41, which is attached to the drive mechanism 47, around the circumference of the gantry 40.

[00103] As shown, for example, in FIGS. 3A and 3B, the drive mechanism 47 is mounted to the rotor 41 beneath the detector array 45, and opposite the x-ray source tube 43. This can be advantageous, since the motorized components of the drive mechanism 47 can result in EM interference with the tube that can affect the position of the x-ray focal spot. By placing the drive mechanism on the opposite side of the rotor 41 from the x-ray source 43, the possibility of EM interference is minimized.

[00104] The foregoing method descriptions are provided merely as illustrative examples and are not intended to require or imply that the steps of the various embodiments must be performed in the order presented. As will be appreciated by one of skill in the art the order of steps in the foregoing embodiments may be performed in any order. Words such as “thereafter,” “then,” “next,” etc. are not necessarily intended to limit the order of the steps; these words may be used to guide the reader through the description of the methods. Further, any reference to claim elements in the singular, for example, using the articles “a,” “an” or “the” is not to be construed as limiting the element to the singular.

[00105] The various illustrative logical blocks, modules, circuits, and algorithm steps described in connection with the embodiments disclosed herein may be implemented as electronic hardware, computer software, or combinations of both. To clearly illustrate this interchangeability of hardware and software, various illustrative components, blocks, modules, circuits, and steps have been described above generally in terms of their functionality. Whether such functionality is implemented as hardware or software depends upon the particular application and design constraints imposed on the overall system. Skilled artisans may implement the described functionality in varying ways for each particular application, but such implementation decisions should not be interpreted as causing a departure from the scope of the present invention.

[00106] The hardware used to implement the various illustrative logics, logical blocks, modules, and circuits described in connection with the aspects disclosed herein may be implemented or performed with a general purpose processor, a digital signal processor (DSP), an application specific integrated circuit (ASIC), a field programmable gate array (FPGA) or other programmable logic device, discrete gate or transistor logic, discrete hardware components, or any combination thereof designed to perform the functions described herein. A general-purpose processor may be a microprocessor, but, in the alternative, the processor may be any conventional processor, controller, microcontroller, or state machine. A processor may also be implemented as a combination of computing devices, e.g., a combination of a DSP and a microprocessor, a plurality of microprocessors, one or more microprocessors in conjunction with a DSP core, or any other such configuration. Alternatively, some steps or methods may be performed by circuitry that is specific to a given function.

[00107] In one or more exemplary aspects, the functions described may be implemented in hardware, software, firmware, or any combination thereof. If implemented in software, the functions may be stored on or transmitted over as one or more instructions or code on a computer-readable medium. The steps of a method or algorithm disclosed herein may be embodied in a processor-executable software module executed which may reside on a computer-readable medium. Computer-readable media includes both computer storage media and communication media including any medium that facilitates transfer of a computer program from one place to another. A storage media may be any available media that may be accessed by a computer. By way of example, and not limitation, such computer-readable media may comprise RAM, ROM, EEPROM, CD-ROM or other optical disk storage, magnetic disk storage or other magnetic storage devices, or any other medium that may be used to carry or store desired program code in the form of instructions or data structures and that may be accessed by a computer. Also, any connection is properly termed a computer-readable medium. For example, if the software is transmitted from a website, server, or other remote source using a coaxial cable, fiber optic cable, twisted pair, digital subscriber line (DSL), or wireless technologies such as infrared, radio,

and microwave, then the coaxial cable, fiber optic cable, twisted pair, DSL, or wireless technologies such as infrared, radio, and microwave are included in the definition of medium. Disk and disc, as used herein, includes compact disc (CD), laser disc, optical disc, digital versatile disc (DVD), floppy disk, and blu-ray disc where disks usually reproduce data magnetically, while discs reproduce data optically with lasers. Combinations of the above should also be included within the scope of computer-readable media. Additionally, the operations of a method or algorithm may reside as one or any combination or set of codes and/or instructions on a machine readable medium and/or computer-readable medium, which may be incorporated into a computer program product.

[00108] The preceding description of the disclosed aspects is provided to enable any person skilled in the art to make or use the present invention. Various modifications to these aspects will be readily apparent to those skilled in the art, and the generic principles defined herein may be applied to other aspects without departing from the scope of the invention. Thus, the present invention is not intended to be limited to the aspects shown herein but is to be accorded the widest scope consistent with the principles and novel features disclosed herein.

What is claimed is:

1. An imaging system, comprising:
 - a rotating portion comprising a rotor and at least one imaging component mounted to the rotor; and
 - a gantry comprising an outer shell that substantially fully encloses the rotating portion over one or more sides of the rotating portion, the outer shell further comprising a mounting surface for a bearing that enables the rotating portion to rotate 360° within the outer shell.
2. The imaging system of claim 1, wherein the gantry comprises a generally O-shaped gantry defining an internal bore.
3. The imaging system of claim 2, wherein the outer diameter of the gantry is less than about 70 inches.
4. The imaging system of claim 3, wherein the outer diameter of the gantry is between about 60 and 68 inches.
5. The imaging system of claim 2, wherein the bore diameter of the gantry is greater than about 38 inches.
6. The imaging system of claim 5, wherein the bore diameter is between about 38 and 50 inches.
7. The imaging system of claim 5, wherein the outer diameter of the gantry is less than about 70 inches.
8. The imaging system of claim 2, wherein the gantry has a width that is less than about 17 inches.

9. The imaging system of claim 8, wherein the gantry has a width that is less than about 15 inches.
10. The imaging system of claim 8, wherein the outer diameter of the gantry is less than about 70 inches and the bore diameter is greater than 38 inches.
11. The imaging system of claim 1, wherein the outer shell is composed of a structural material that supports the rotating portion in three dimensions.
12. The imaging system of claim 11, wherein the structural material comprises aluminum.
13. The imaging system of claim 1, wherein the outer shell supports at least about 75% of the weight of the rotating portion.
14. The imaging system of claim 1, wherein the gantry is attached to an additional support member, wherein the gantry may tilt and/or rotate with respect to the support member.
15. The imaging system of claim 1, wherein the outer shell comprises a circumferential wall that substantially fully encloses the rotating portion around an outer circumference of the rotating portion.
16. The imaging system of claim 15, wherein the outer shell comprises a first side wall that substantially fully encloses the rotating portion around one side of the rotating portion.
17. The imaging system of claim 16, wherein the outer shell comprises a second side wall, the first and second side walls and the circumferential wall defining a cavity within which the imaging components rotate.

18. The imaging system of claim 16, wherein one or more of the outer shell, a bearing assembly and the rotor define a second side wall, the first and second side walls and the circumferential wall defining a cavity within which the imaging components rotate.
19. The imaging system of claim 1, wherein the imaging components comprise an x-ray source and a detector.
20. The imaging system of claim 19, further comprising one or more of a battery system, a high-voltage generator, a heat exchanger, a computer, and a rotor drive mechanism mounted to the rotor.
21. The imaging system of claim 1, further comprising a bearing system for enabling the rotation of the rotating portion with respect to the outer shell of the gantry.
22. The imaging system of claim 21, wherein the bearing system comprises a first race fixed to the outer shell, a second race fixed to the rotating portion, and a bearing element between the first race and the second race that allows the first race and the second race to rotate concentrically relative to one another.
23. The imaging system of claim 22, wherein the bearing mounting surface on the outer shell comprises a first race that is integrally formed in the outer shell.
24. The imaging system of claim 22, wherein the bearing mounting surface comprises a surface to which a first race portion of a bearing assembly may be securely fastened.
25. The imaging system of claim 22, wherein the second race is integrally formed as a part of the rotor.

26. The imaging system of claim 22, wherein the second race comprises part of a bearing assembly that may be securely fastened to the rotor.
27. The imaging system of claim 1, wherein at least one component mounted to the rotor comprises at least one surface that is angled or curved to substantially correspond with a curvature of the gantry or bore.
28. The imaging system of claim 27, wherein the at least one component comprises a high-voltage generator.
29. The imaging system of claim 27, wherein the at least one component comprises a chassis for a battery system.
30. The imaging system of claim 1, further comprising a rotor drive system mounted to the rotor.
31. The imaging system of claim 30, wherein the rotor drive system engages with an element fixed to the outer shell of the gantry to drive the rotation of the rotating portion within the gantry.
32. The imaging system of claim 31, wherein the element is fixed to a first side wall of the outer shell, and a bearing system is provided on a second side wall of the outer shell, opposite the first side wall.
33. The imaging system of claim 21, wherein the bearing system is located within the gantry.
34. The imaging system of claim 1, wherein the imaging system comprises a mobile imaging system.
35. A mobile diagnostic imaging system, comprising:

a first portion;

a second portion, wherein the first portion rotates with respect to the second portion to obtain an image of an object;

a battery system on the first portion that comprises a plurality of battery power sources that provide power to one or more imaging components on the first portion and a control system that monitors and controls the state of charge of each of the battery power sources; and

a charging system on the second portion for charging the battery system when the system is not obtaining images.

36. The system of claim 35, wherein the second portion comprises a gantry having an internal cavity and the first portion comprises a rotor that rotates within the internal cavity of the gantry.
37. The system of claim 35, wherein the imaging components comprise an x-ray source.
38. The system of claim 35, wherein the battery system includes one or more battery packs, each comprising one or more electrochemical cells.
39. The system of claim 38, wherein the electrochemical cells comprise lithium iron phosphate (LiFePO₄) cells.
40. The system of claim 38, further comprising a control circuit associated with each battery pack that monitors and/or alters the state of charge of each of the electrochemical cells.
41. The system of claim 40, wherein the control circuit implements a control scheme that causes the electrochemical cells have a substantially similar charge state.

42. The system of claim 40, further comprising a communication network that allows the battery packs to communicate with each other to implement a control scheme that causes the electrochemical cells to have a substantially similar charge state.
43. The system of claim 40, further comprising a main battery control circuit that implements a control scheme that causes the electrochemical cells to be of a substantially similar charge state.
44. The system of claim 35, wherein the battery system communicates with the charging system to terminate a charging operation when one or more of the electrochemical cells reach a full state of charge.
45. The system of claim 35, wherein the charging system is connected to an external power source.
46. The system of claim 45, wherein the external power source comprises a standard grid power outlet.
47. The system of claim 35, further comprising a docking system that selectively couples and decouples the rotating and non-rotating portions of the imaging system.
48. The system of claim 47, wherein the charging system charges the battery system when the rotating and non-rotating portions are coupled by the docking system.
49. The system of claim 47, wherein the docking system decouples the rotating and non-rotating portions during an image scan.

50. The system of claim 35, further comprising a non-contact signaling system provided at one or more discrete locations on both the rotating and non-rotating portions of the system that enables communication between the rotating and non-rotating portions of the system during an imaging scan.
51. The system of claim 50, wherein the non-contact signaling system coordinates the onset or termination of a function within the imaging system.
52. The system of claim 50, wherein the non-contact signaling system utilizes optical signals.
53. The system of claim 50, wherein the non-contact signaling system utilizes magnetic signals.
54. The system of claim 50, wherein the non-contact signaling system comprises at least one transmitter and at least one detector provided on both the rotating and non-rotating portions to provide two-way communication between the rotating and non-rotating portions.
55. The system of claim 35, wherein the system comprises a computed tomography (CT) imaging system.
56. The system of claim 35, wherein the system comprises a magnetic resonance (MR) imaging system.
57. The system of claim 35, further comprising a drive mechanism for rotating the first portion relative to the second portion.
58. The system of claim 57, wherein the drive mechanism is powered by the battery system.

59. The system of claim 57, wherein the drive mechanism comprises a belt that is provided on the second portion and a motor-driven gear that is provided on the first portion, the motor-driven gear being driven to mesh with the belt to rotate the first portion relative to the second portion.
60. A mobile diagnostic imaging system, comprising:
a rotatable portion;
a non-rotatable portion, wherein the rotatable portion rotates with respect to the non-rotatable portion to obtain an image of an object;
a power supply on the rotatable portion;
a docking system that selectively engages to electrically connect the rotatable portion and the non-rotatable portion and prevent the rotatable portion from rotating with respect to the non-rotatable portion, and selectively disengages to electrically disconnect the rotatable portion and the non-rotatable portion during an image scan.
61. The system of claim 60, wherein the docking system comprises a first docking portion on one of the rotatable and non-rotatable portions and a second docking portion on the other of the rotatable and non-rotatable portions, the first docking portion comprising a first electrical connector and a first alignment feature and the second docking portion comprising a second electrical connector and a second alignment feature, the first and second electrical connectors and the first and second alignment features configured to mate with one another when the system is docked.
62. The system of claim 61, wherein the first alignment feature comprises a pin or rod and the second element comprises a recess configured to receive the first alignment feature.
63. The system of claim 61, wherein the first docking portion comprises an actuator that drives the first alignment feature into mating engagement with the

second alignment feature to prevent the rotating portion from rotating with respect to the non-rotating portion.

64. The system of claim 63, wherein the actuator drives the first electrical connector into mating engagement with the second electrical connector after the respective alignment features are engaged.
65. The system of claim 64, wherein the first docking portion is located on the rotating portion and the second docking portion is located on the non-rotating portion.
66. The system of claim 65, wherein the first docking portion is located on a rotor that rotates inside an outer shell of a gantry, and the second docking portion is located on a gimbal support that supports the outer shell of the gantry.
67. The system of claim 66, wherein the gimbal support comprises a rotating bearing that allows the outer shell of the gantry and rotor to tilt with respect to the gimbal support, and the second docking portion is located on the bearing to allow the docking system to engage and disengage while the gantry is tilted.
68. The system of claim 60, wherein prior to engaging or disengaging the docking system, a higher voltage is maintained on the non-rotating portion relative to the rotating portion.
69. The system of claim 60, wherein the docking system comprises a relay that is opened prior to engaging or disengaging the docking system to prevent current from flowing across the docking system from the non-rotating portion to the rotating portion.

70. The system of claim 69, wherein the docking system comprises an inrush current limiting device that limits the inrush current to the rotating portion when the relay is closed.
71. The system of claim 69, wherein the relay comprises a solid state relay.
72. The system of claim 69, wherein the docking system permits power to flow from the power supply to the non-rotating portion while the docking system is engaged.
73. The system of claim 60, wherein the system comprises a mobile system, and wherein the power supply on the rotating portion provides power to a system drive mechanism for transporting the imaging system when the docking system is engaged.
74. The system of claim 65, wherein the power supply on the rotatable portion provides power to the first docking portion.
75. The system of claim 60, wherein the power supply on the rotatable portion comprises one or more batteries.
76. The system of claim 60, wherein the docking system enables flow of power and data between the rotatable and non-rotatable portions when the docking system is engaged.
77. The system of claim 60, further comprising a non-contact signaling system provided at one or more discrete locations on both the rotatable and non-rotatable portions of the system that enables communication between the rotatable and non-rotatable portions of the system when the docking system is disengaged.

78. The system of claim 77, wherein the non-contact signaling system coordinates the onset or termination of a function within the imaging system.
79. The system of claim 77, wherein the non-contact signaling system utilizes optical signals.
80. The system of claim 77, wherein the non-contact signaling system utilizes magnetic signals.
81. The system of claim 77, wherein the non-contact signaling system transmits an enable scan signal between the non-rotatable and rotatable portions of the system during an imaging scan.
82. The system of claim 77, wherein the non-contact signaling system comprises at least one transmitter and at least one detector provided on both the rotating and non-rotating portions to provide two-way communication between the rotating and non-rotating portions.
83. A mobile diagnostic imaging system, comprising:
 - a rotatable portion;
 - a non-rotatable portion, wherein the rotatable portion rotates with respect to the non-rotatable portion to obtain an image of an object;
 - a power supply on the rotatable portion; and
 - a drive mechanism, powered by the battery system, for rotating the rotatable portion relative to the non-rotatable portion.
84. The system of claim 83, wherein the drive mechanism comprises a belt that is provided on the non-rotatable portion and a motor-driven gear that is provided on the rotatable portion, the motor-driven gear being driven to interface with the belt to rotate the rotatable portion relative to the non-rotatable portion.

85. The system of claim 83, wherein the drive mechanism is powered by the power supply on the rotatable portion.
86. A method of imaging an object using an imaging system comprising a rotating portion having a rotor and at least one imaging component mounted to the rotor and a gantry having an outer shell defining a bore and substantially fully enclosing the rotating portion over one or more sides of the rotating portion, the outer shell further comprising a mounting surface for a bearing that enables the rotating portion to rotate 360° within the outer shell, the method comprising:
positioning an object to be imaged within the bore;
rotating the rotating portion within the outer shell of the gantry; and
obtaining images of the object using the at least one imaging component.
87. The method of claim 86, wherein the object to be imaged comprises a human or animal patient and the images obtained comprise diagnostic images.
88. A method of imaging an object using an imaging system that comprises a first portion having a battery system having a plurality of battery power sources and a second portion having a charging system, the method comprising:
monitoring a state of charge of each of the battery power sources;
controlling the state of charge of each of the battery power sources; and
rotating the first portion relative to the second portion to obtain an image of an object.
89. The method of claim 88, wherein the state of charge is controlled to provide a substantially similar charge state for each of the battery power sources.
90. The method of claim 88, further comprising:
charging the plurality of battery power sources using the charging system.

91. The method of claim 90, further comprising:
terminating the charging when one or more of the battery power sources reaches a full state of charge.
92. The method of claim 90, further comprising:
coupling the first portion and the second portion using a docking system to charge the battery power sources using the charging system.
93. The method of claim 92, further comprising:
de-coupling the first portion and the second portion using the docking system to rotate the first portion relative to the second portion.
94. The method of claim 88, wherein the object to be imaged comprises a human or animal patient and the images obtained comprise diagnostic images.
95. A method of imaging an object using an imaging system having a rotatable portion and a non-rotatable portion, comprising:
rotating the rotatable portion with respect to the non-rotatable portion to obtain an image of the object;
engaging a docking system to electrically connect the rotatable portion and the non-rotatable portion and prevent the rotatable portion from rotating with respect to the non-rotatable portion; and
disengaging the docking system to electrically disconnect the rotatable portion and the non-rotatable portion during image acquisition.
96. The method of claim 95, further comprising:
charging a power source on the rotatable portion while the docking system is engaged; and
providing power to components of the rotatable portion with the power source while the docking system is disengaged.

97. The method of claim 95, further comprising:
maintaining a higher voltage on the non-rotatable portion relative to the rotatable portion while the docking system is engaged or disengaged.
98. The method of claim 95, further comprising:
opening a relay prior to engaging or disengaging the docking system to prevent current from flowing across the docking system from the non-rotating portion to the rotating portion.
99. The method of claim 95, further comprising:
sending electronic data and/or control signals between the rotatable and the non-rotatable portions via the docking system when the docking system is engaged.
100. The method of claim 95, further comprising:
transmitting a signal between the rotatable and non-rotatable portions using a non-contact signaling system provided at one or more discrete locations on both the rotatable and non-rotatable portions of the system while the docking system is disengaged.
101. The method of claim 95, wherein the object to be imaged comprises a human or animal patient and the images obtained comprise diagnostic images.
102. A method of imaging an object using an imaging system having a non-rotatable portion and a rotatable portion, comprising:
providing power to a drive mechanism from a power supply, wherein the power supply and drive mechanism are located on the rotatable portion;
operating the drive mechanism to rotate the rotatable portion relative to the non-rotatable portion; and
obtaining images of the object while the rotatable portion rotates.

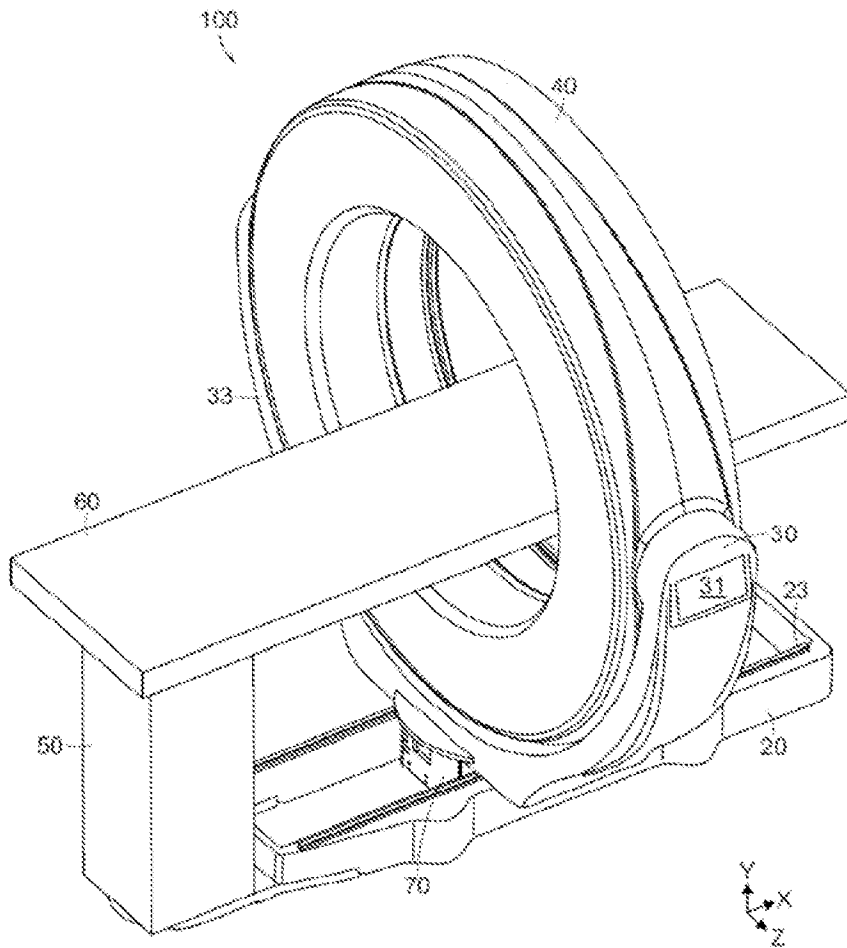

FIG. 1

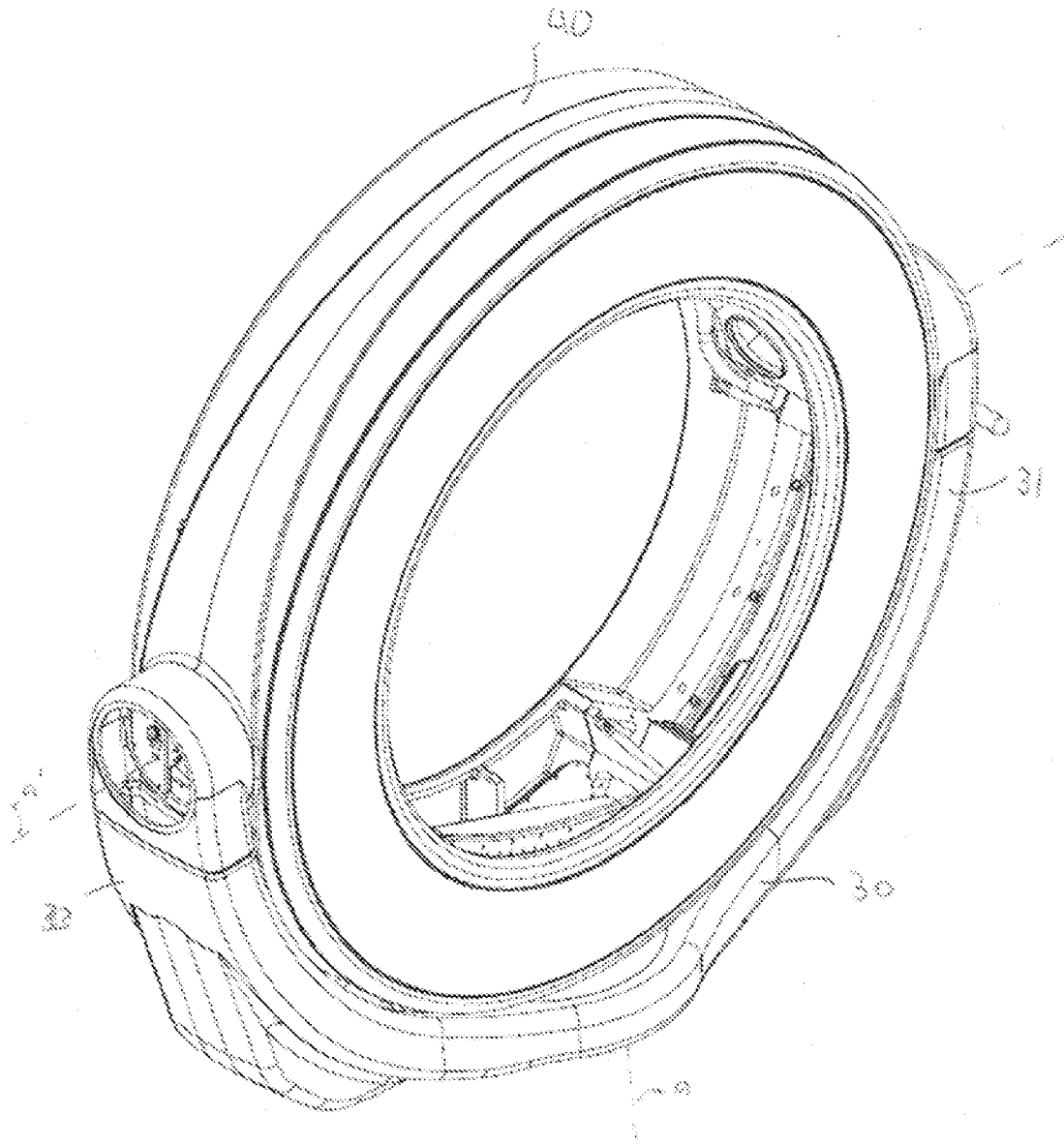

FIG. 2A

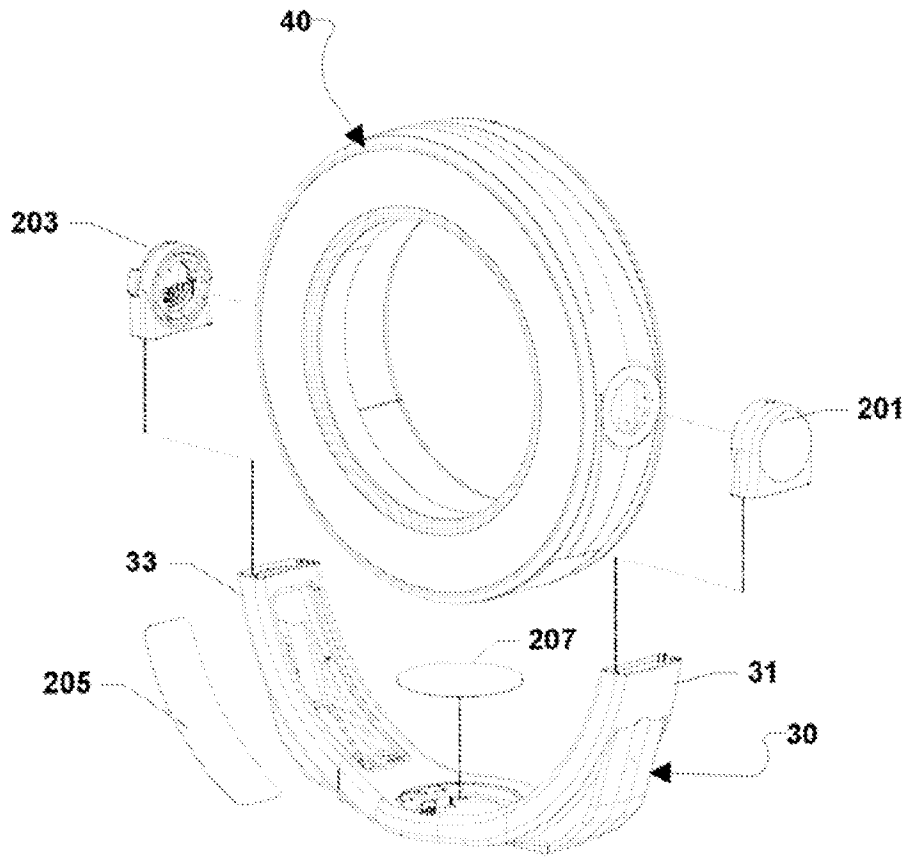

FIG. 2B

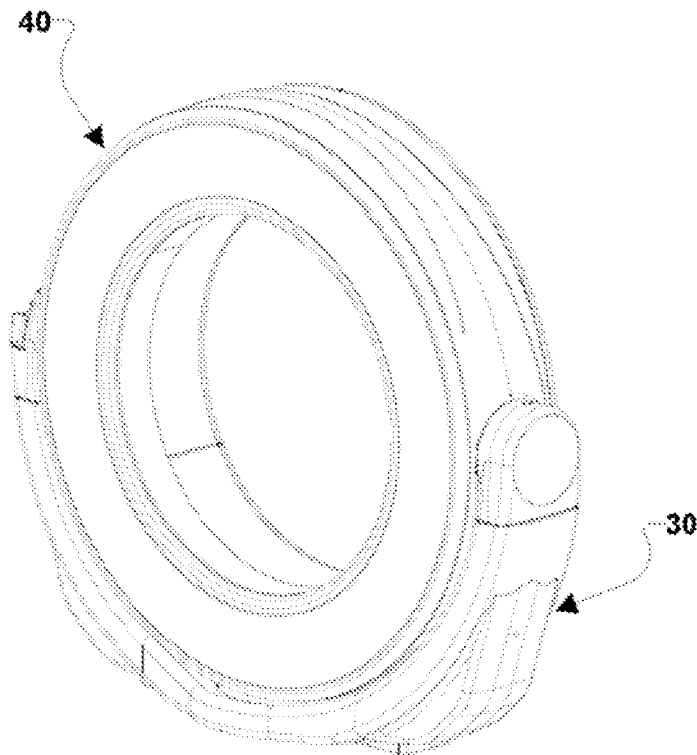

FIG. 2C

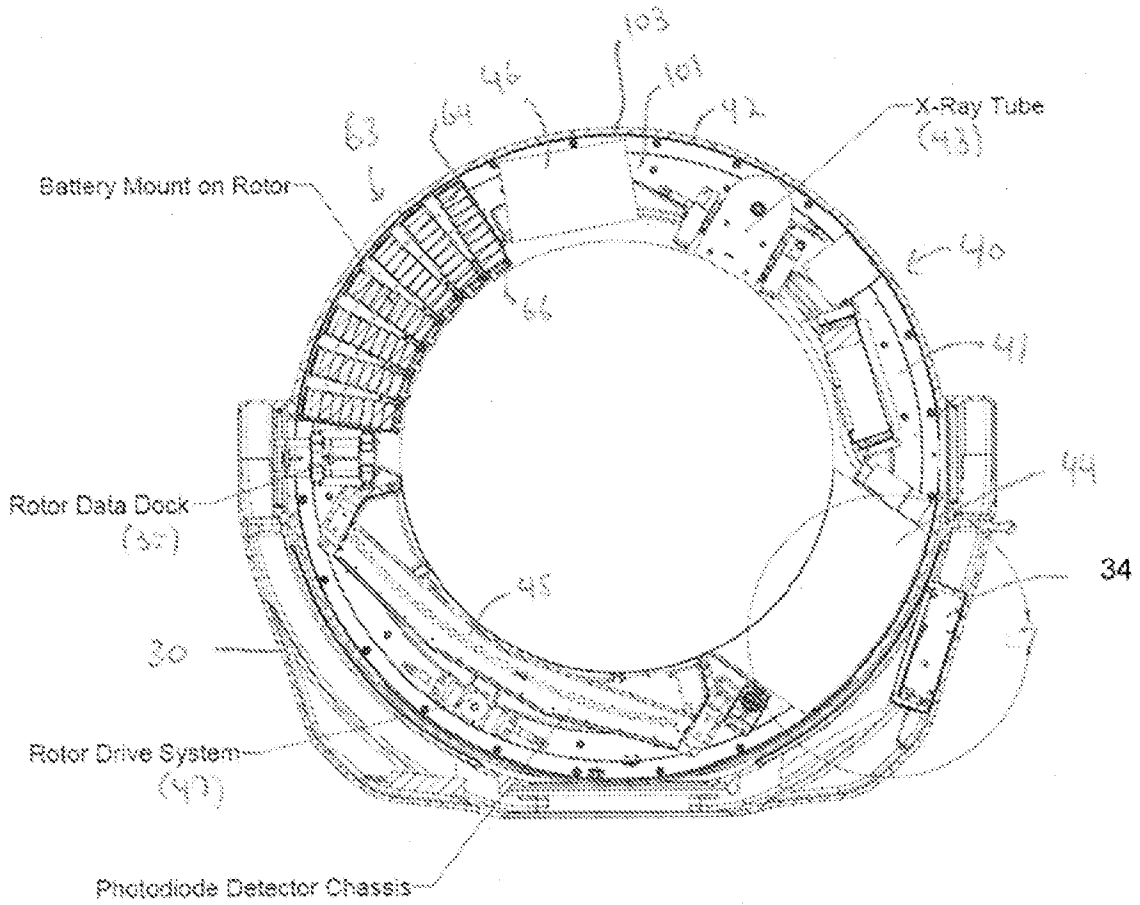

FIG. 3A

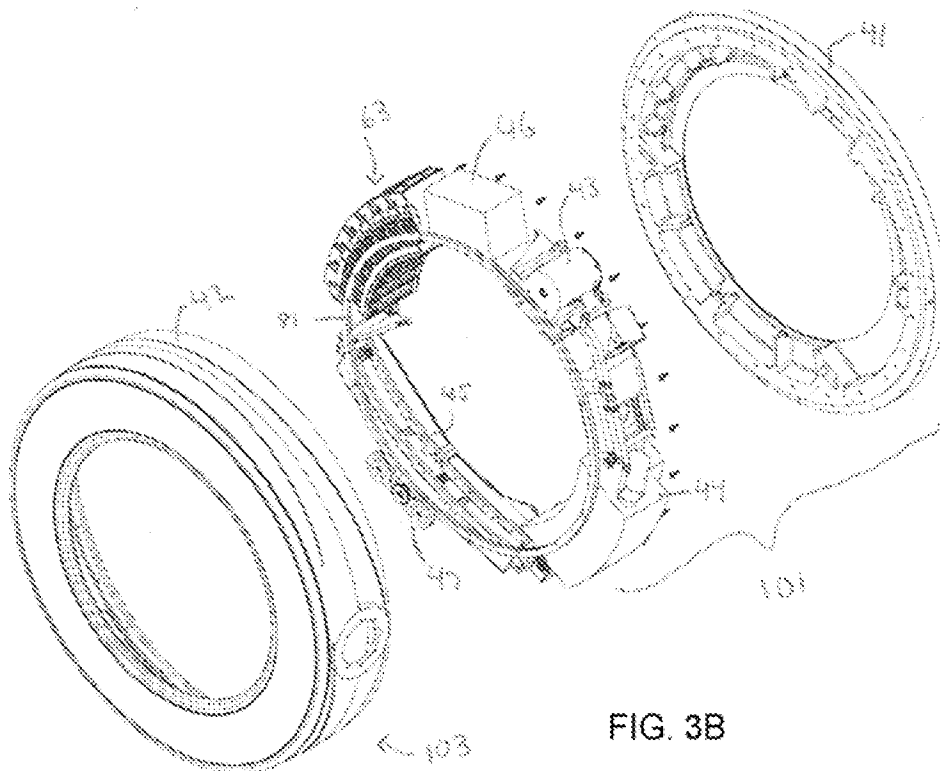

FIG. 3B

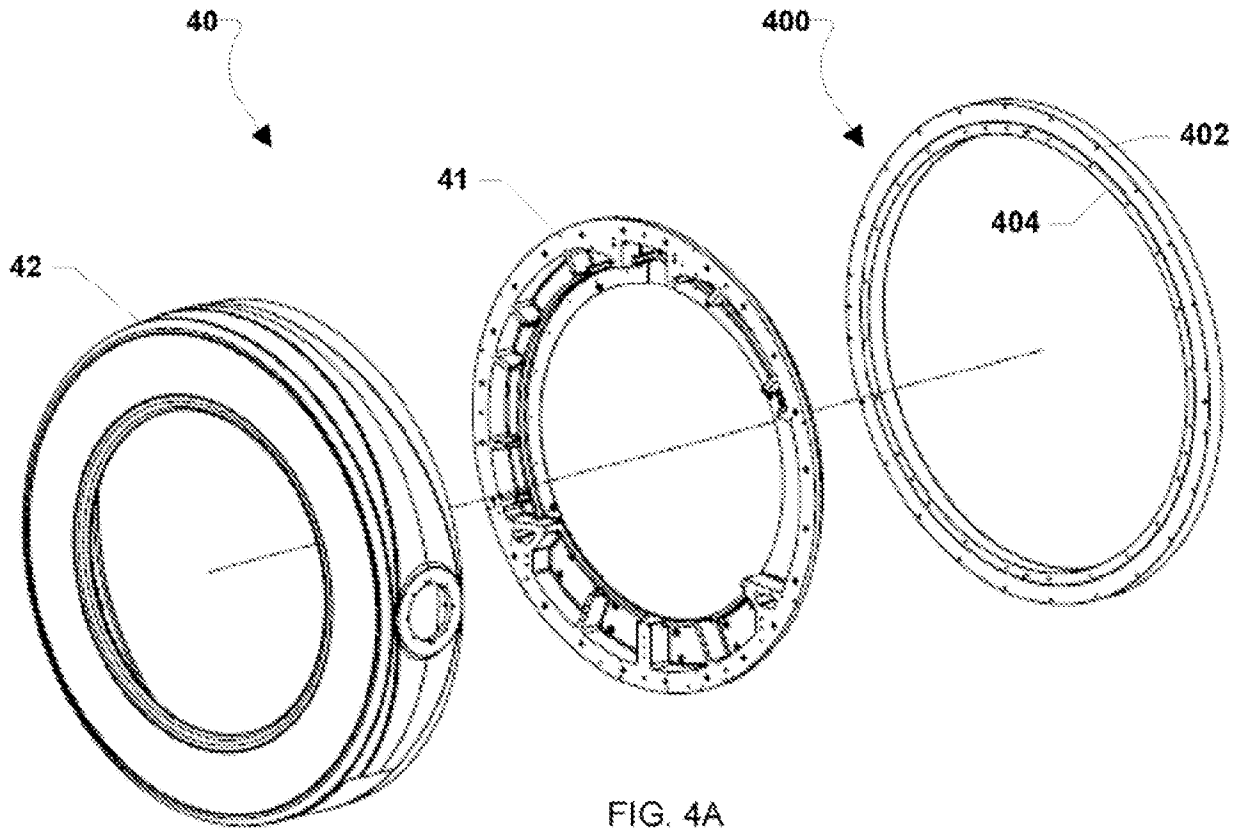

FIG. 4A

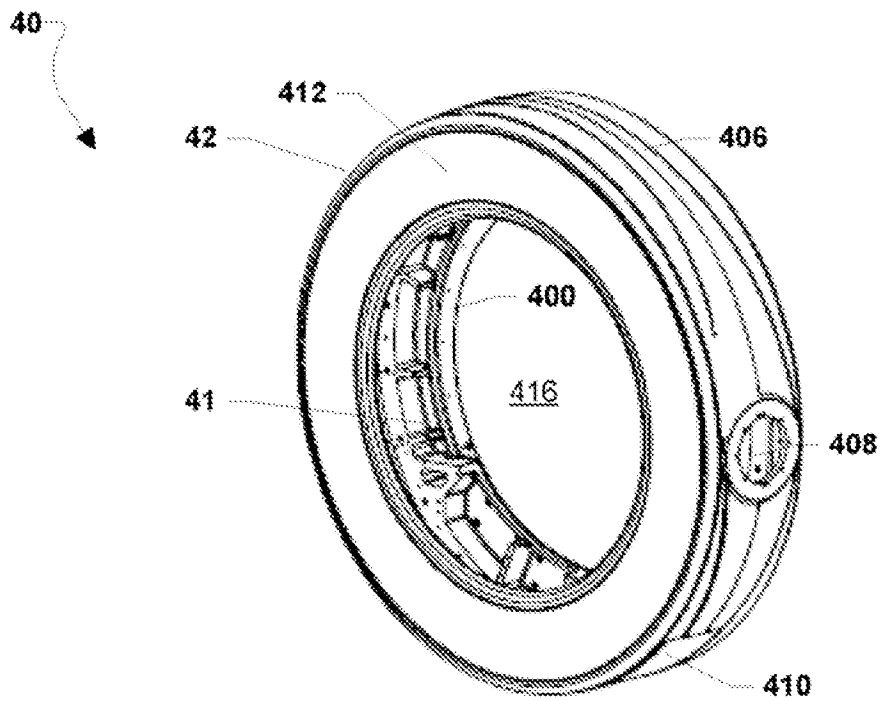

FIG. 4B

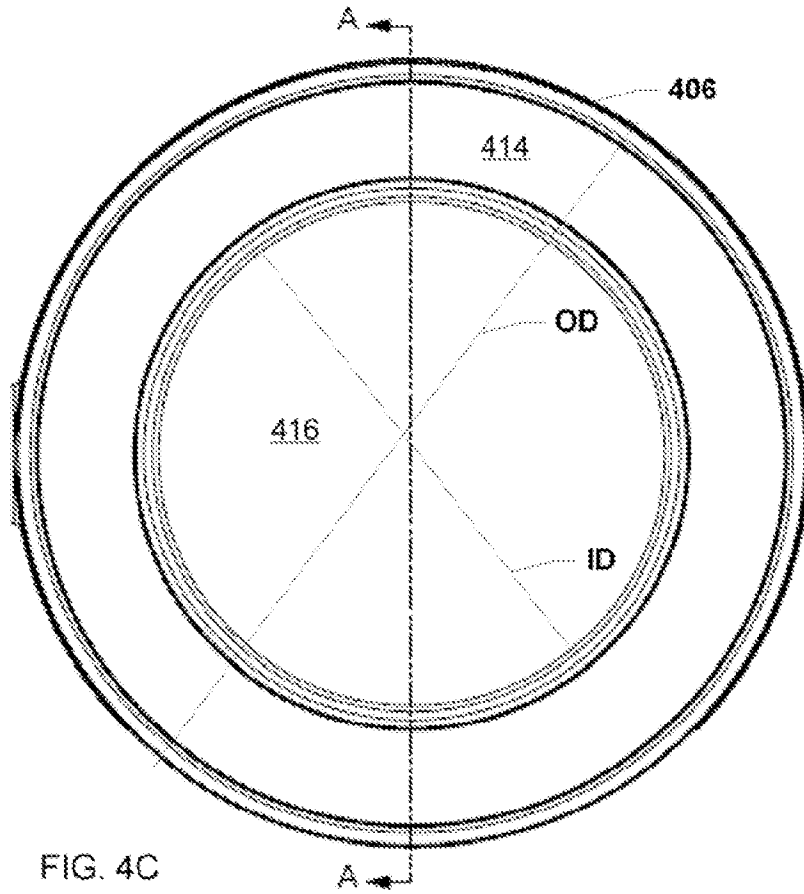
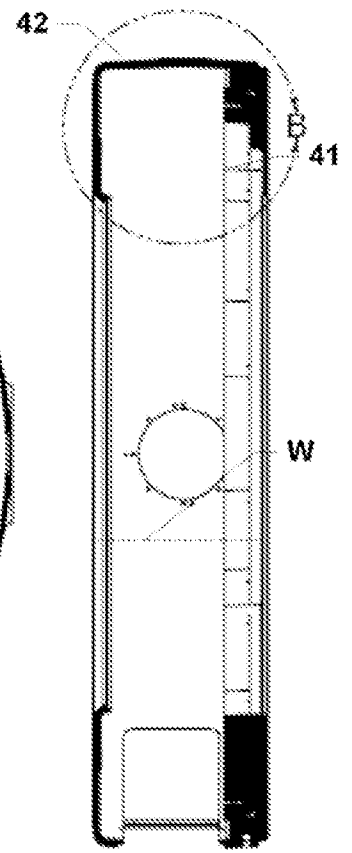

FIG. 4C



SECTION A-A

FIG. 4D

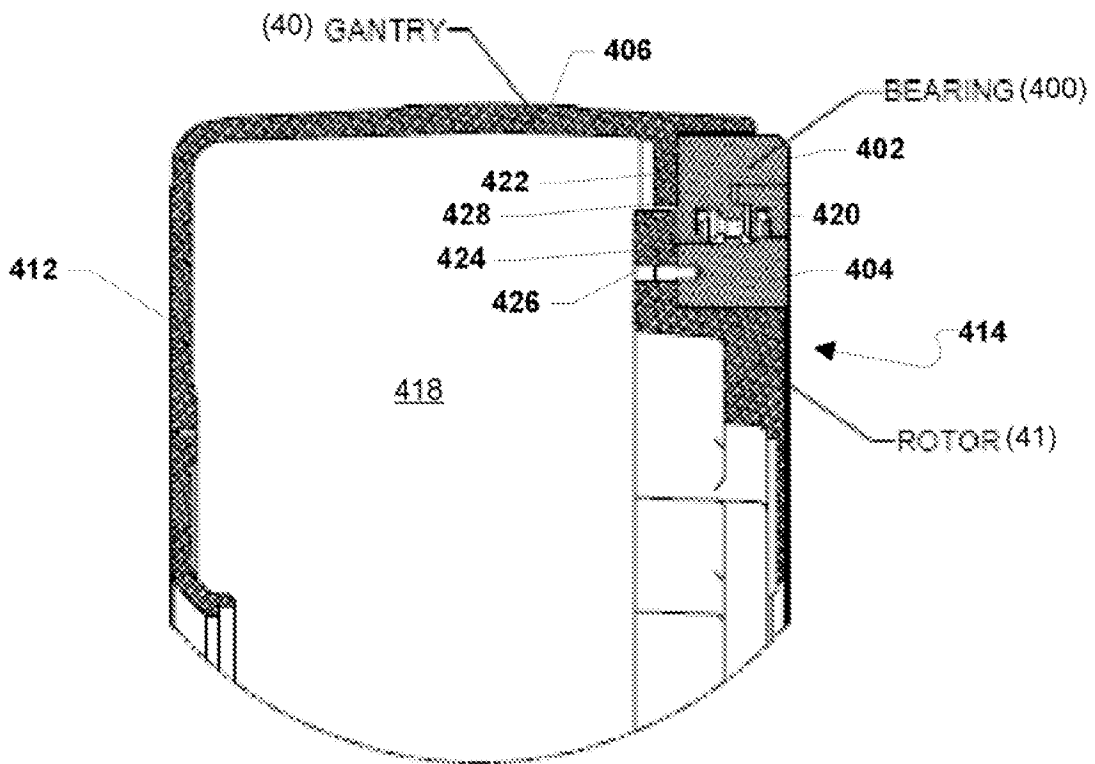

FIG. 4E

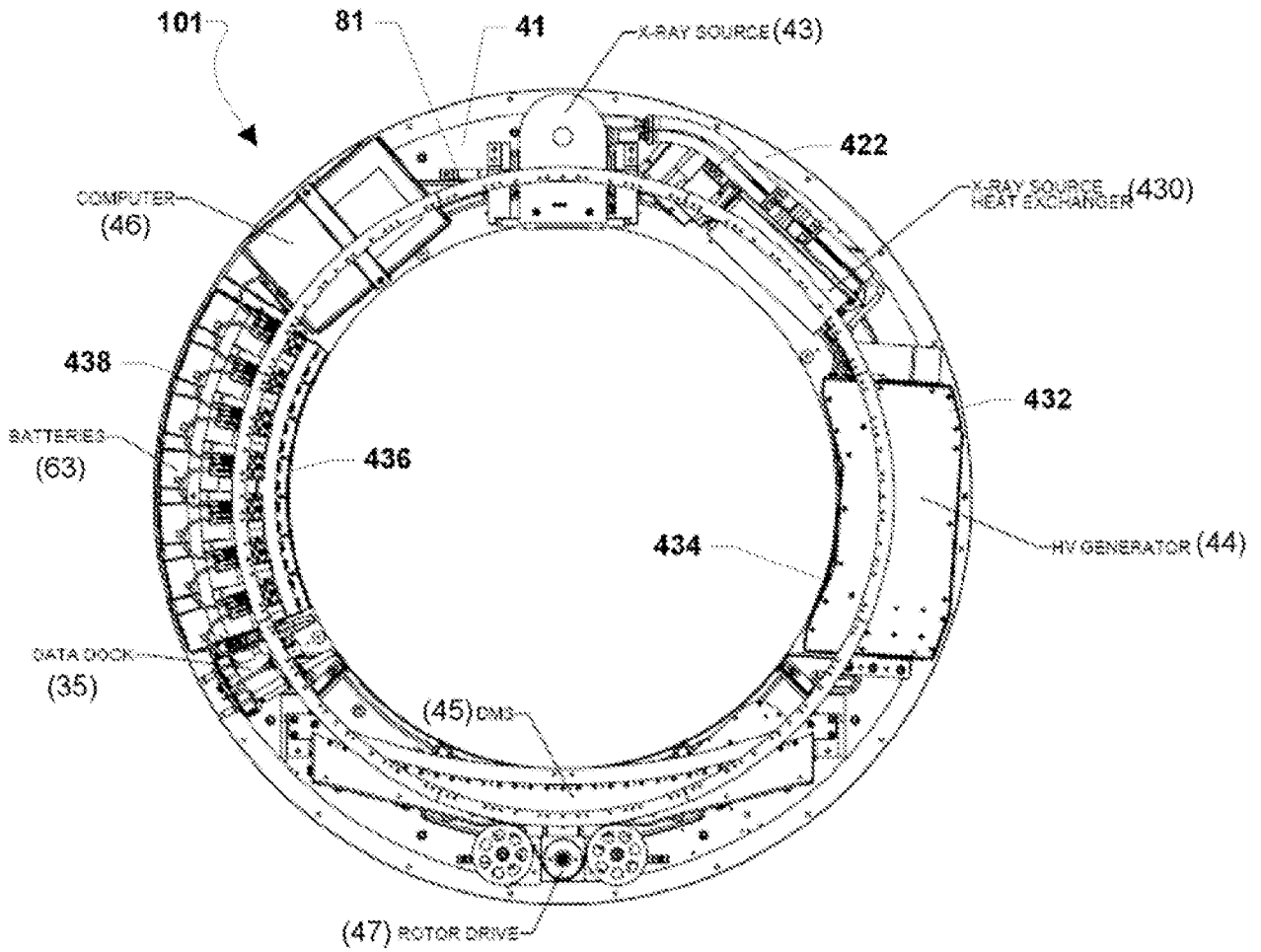

FIG. 4F

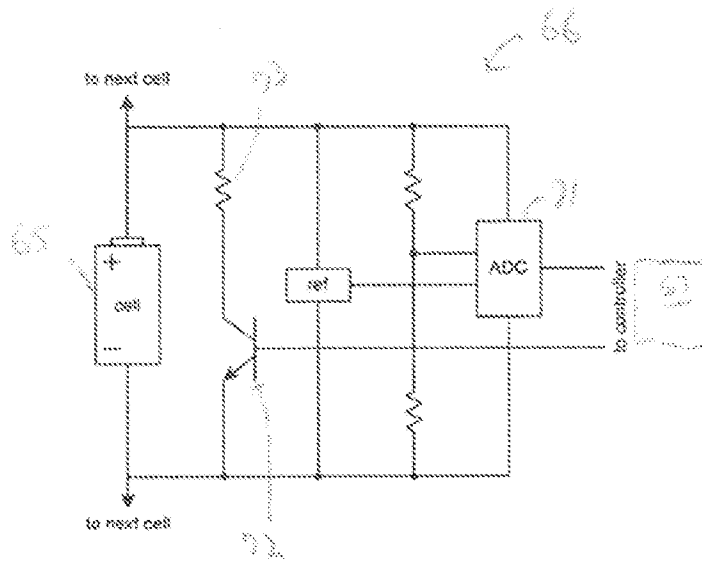

FIG. 5

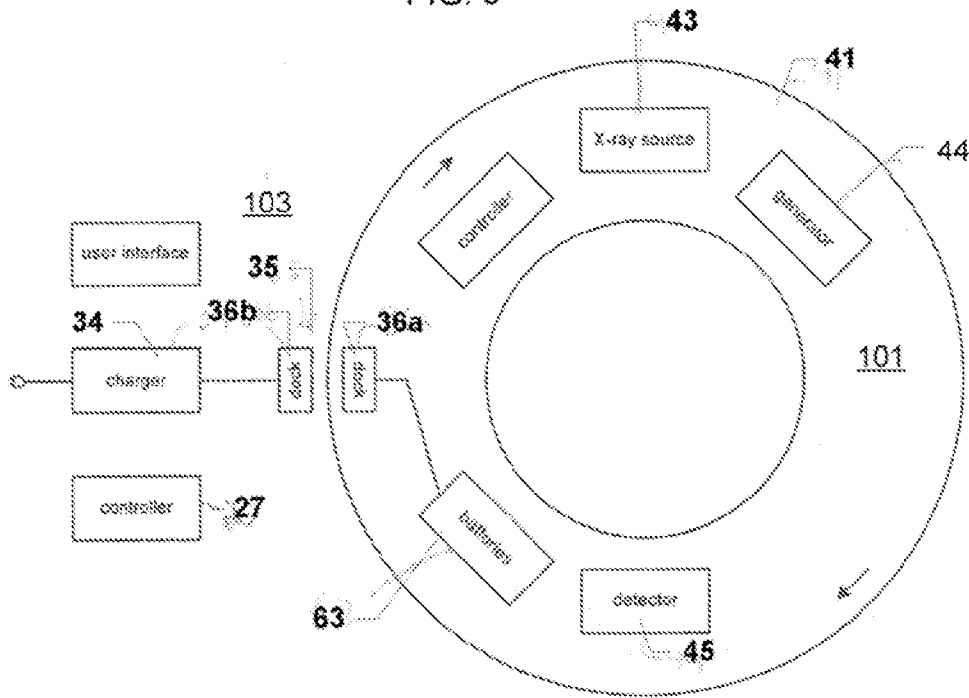

FIG. 6A

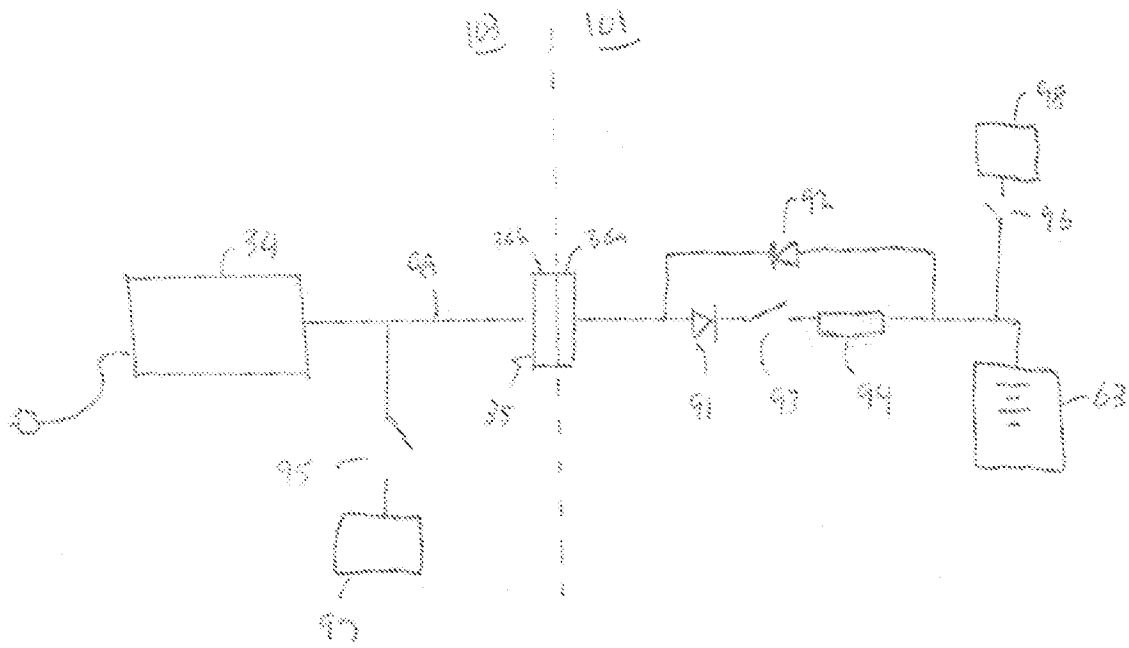

FIG. 6B

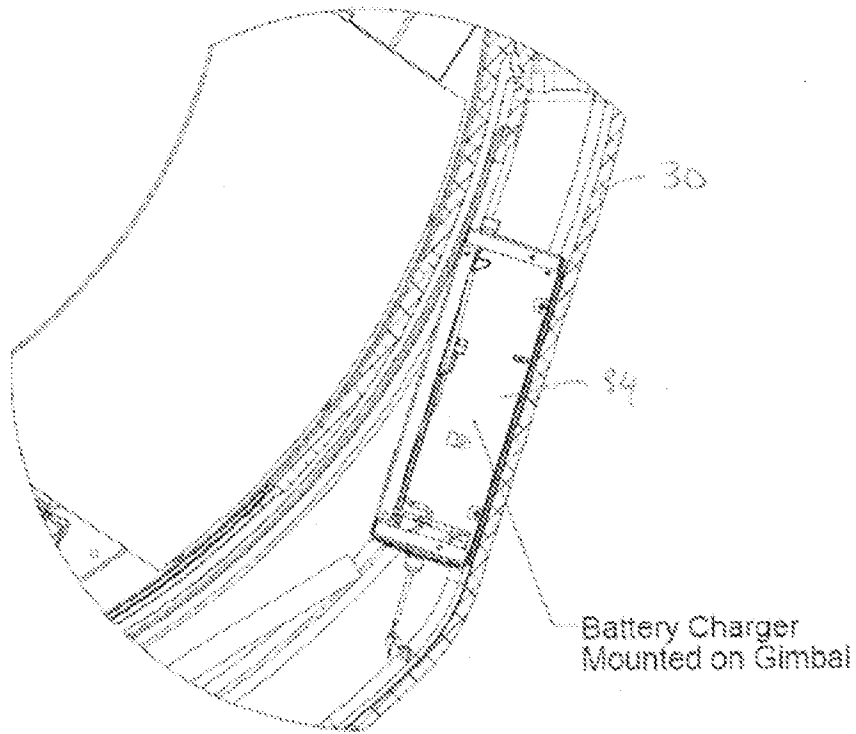

FIG. 7

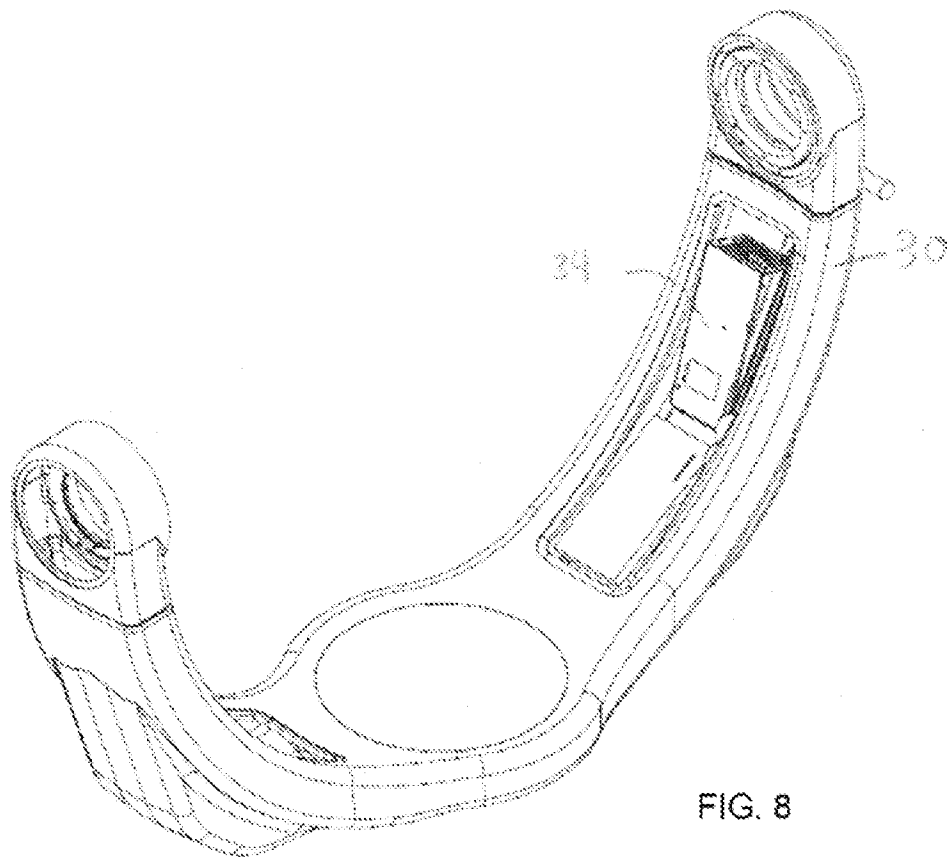

FIG. 8

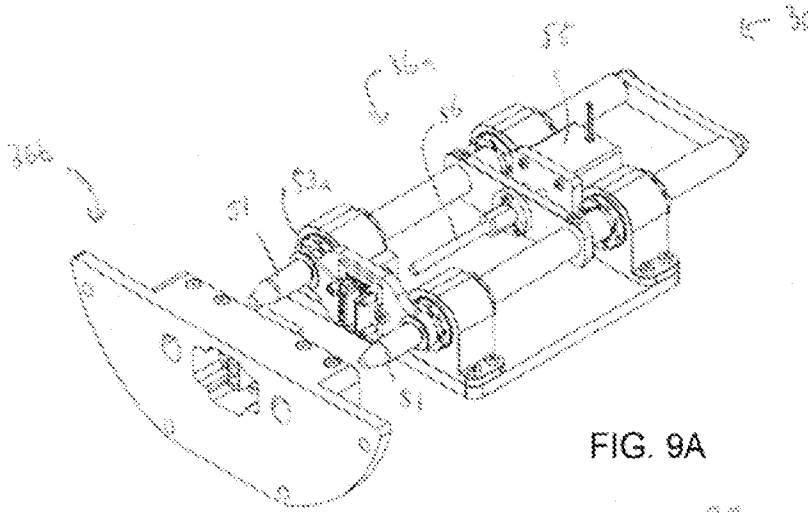

FIG. 9A

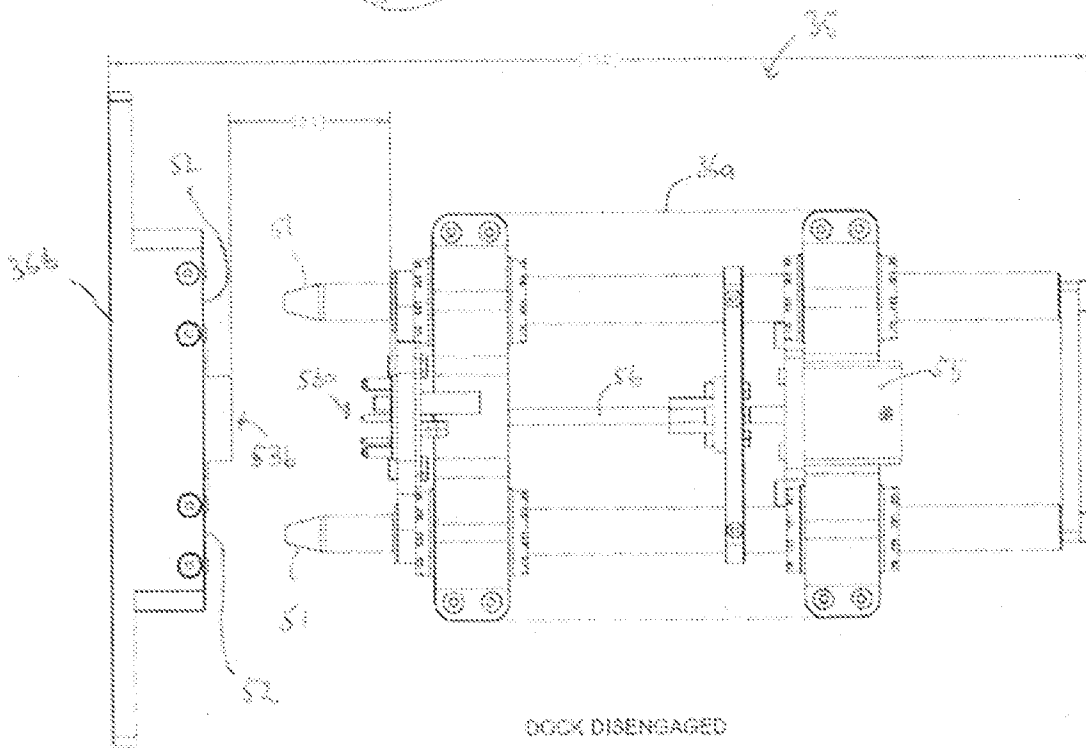

FIG. 9B

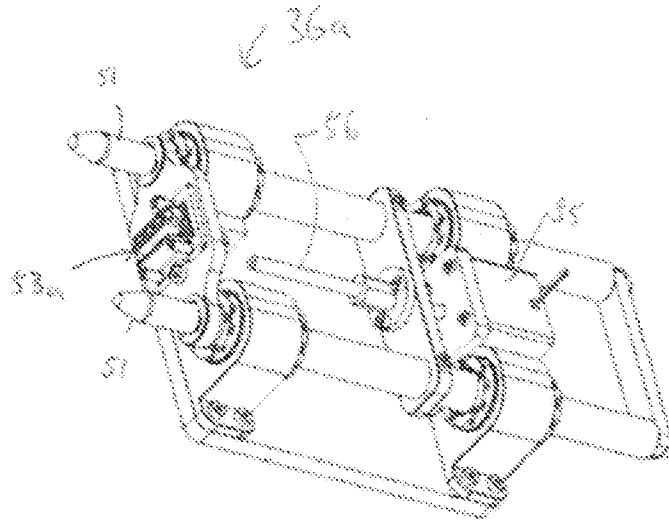

FIG. 11A

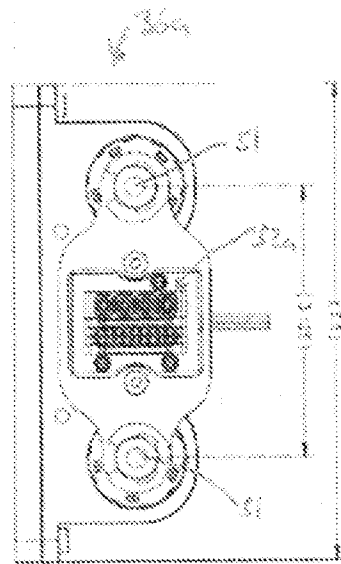

FIG. 11B

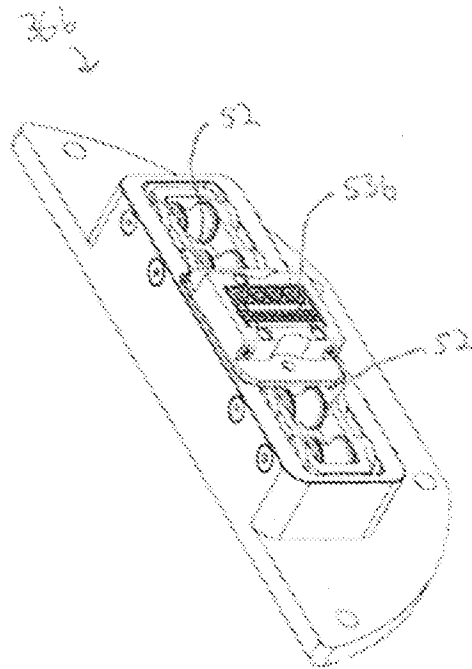

FIG. 12A

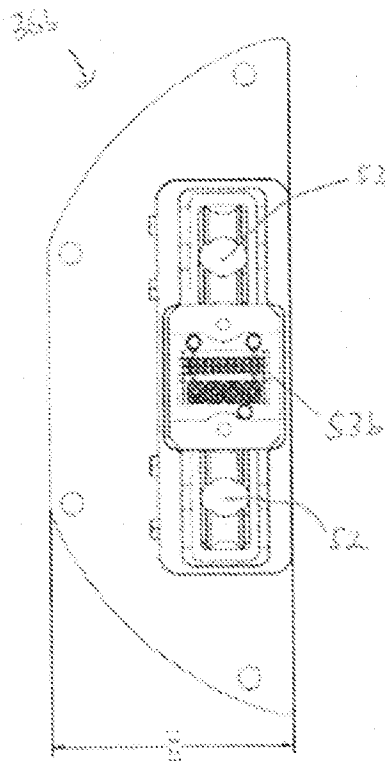

FIG. 12B

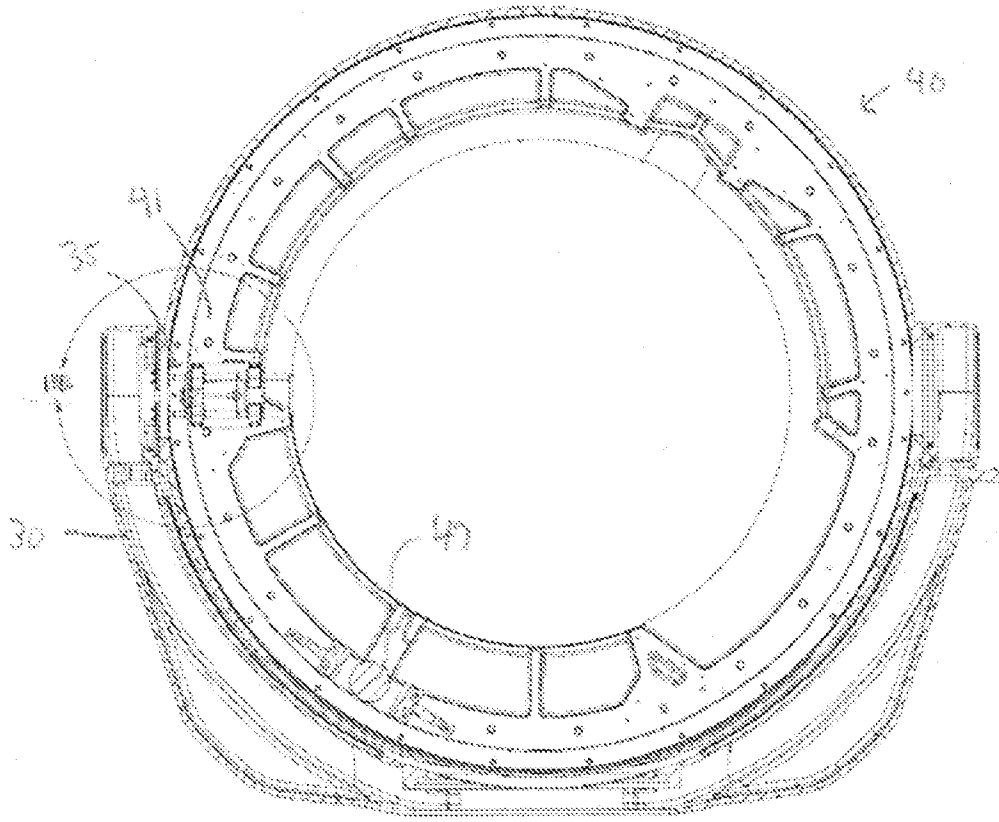

FIG. 13A

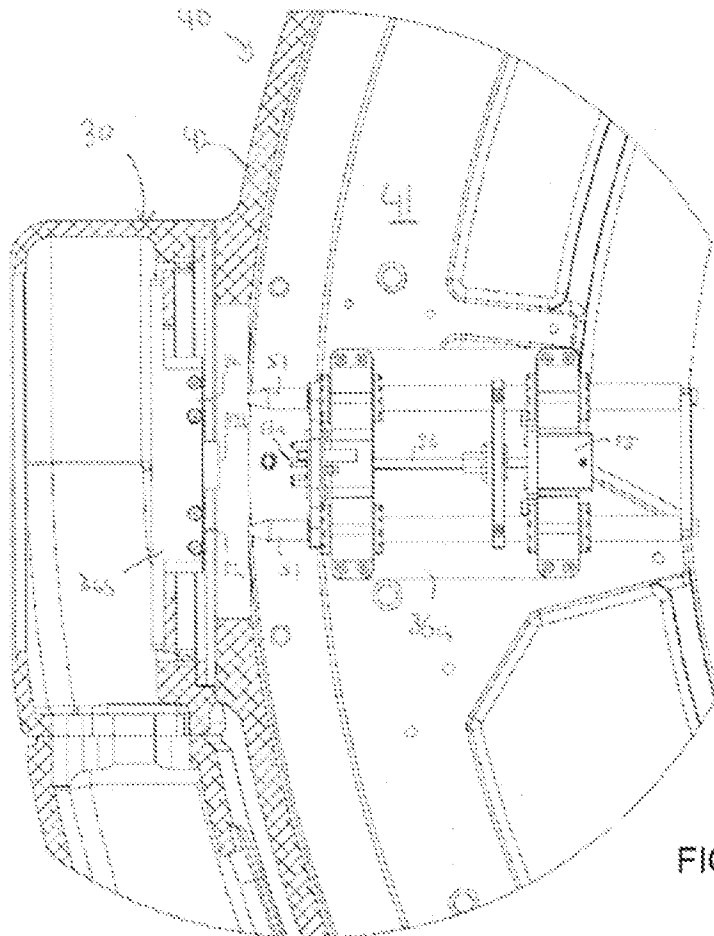

FIG. 13B

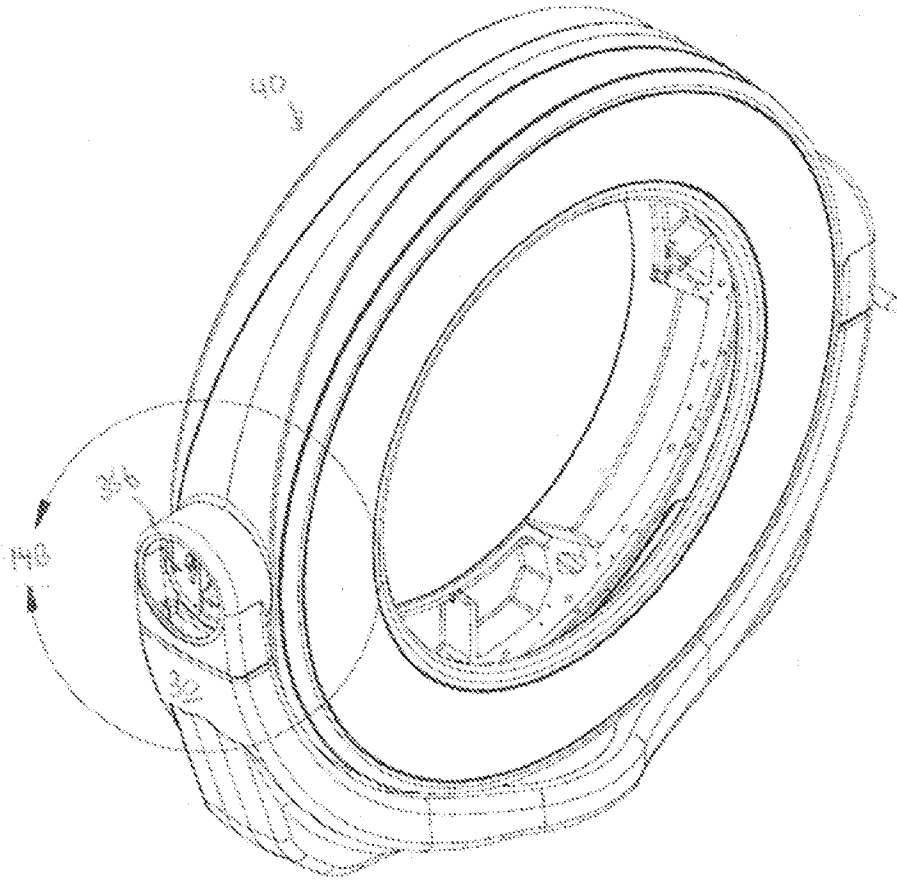

FIG. 14A

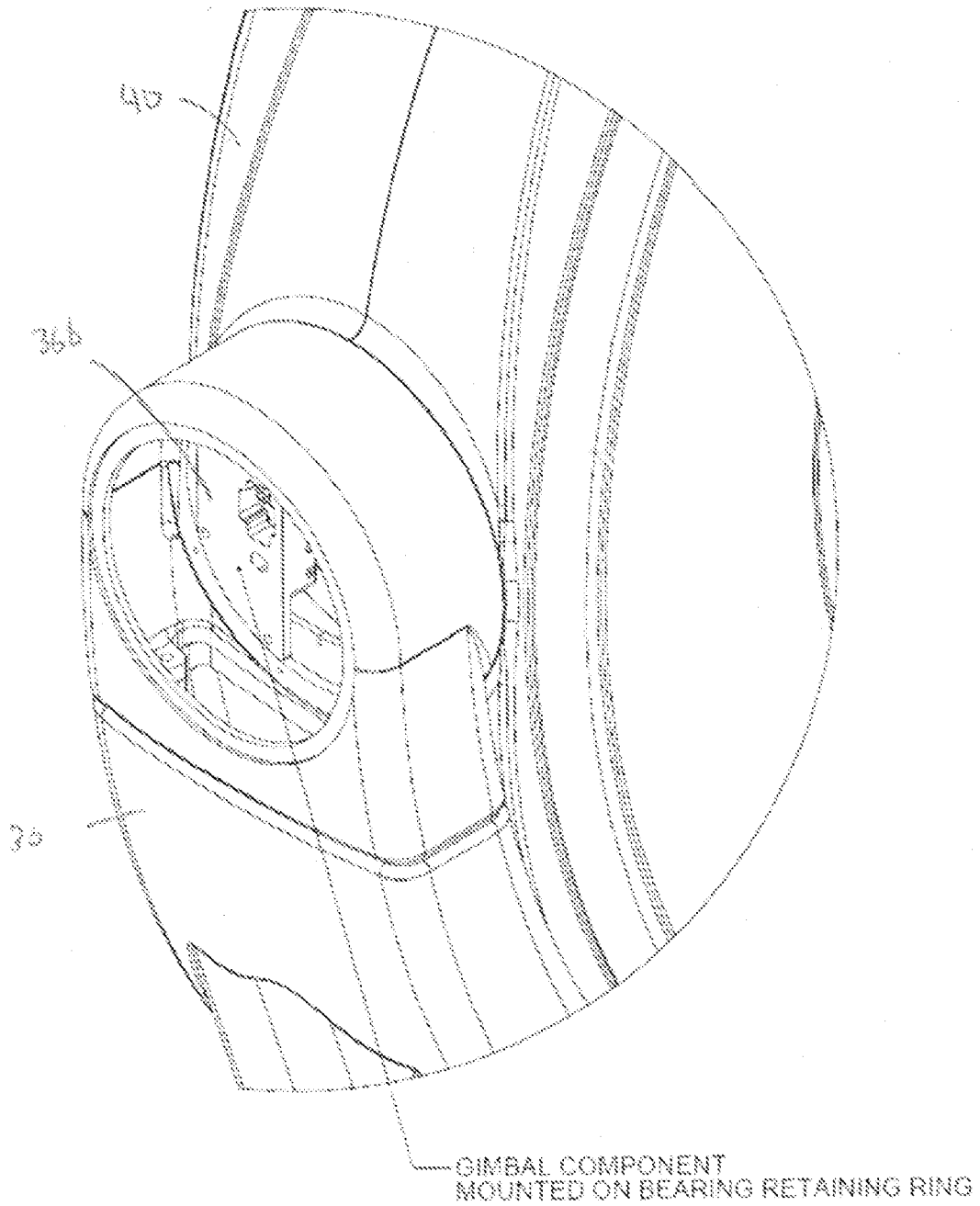

FIG. 14B

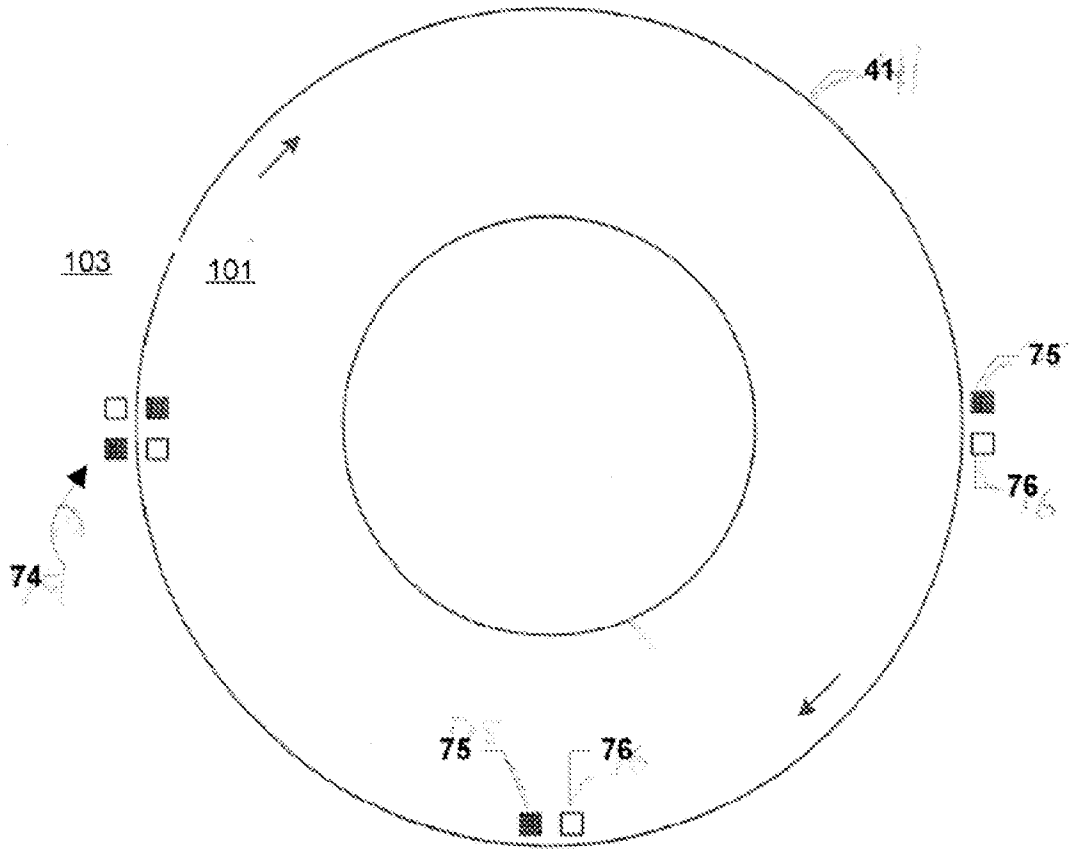

FIG. 15

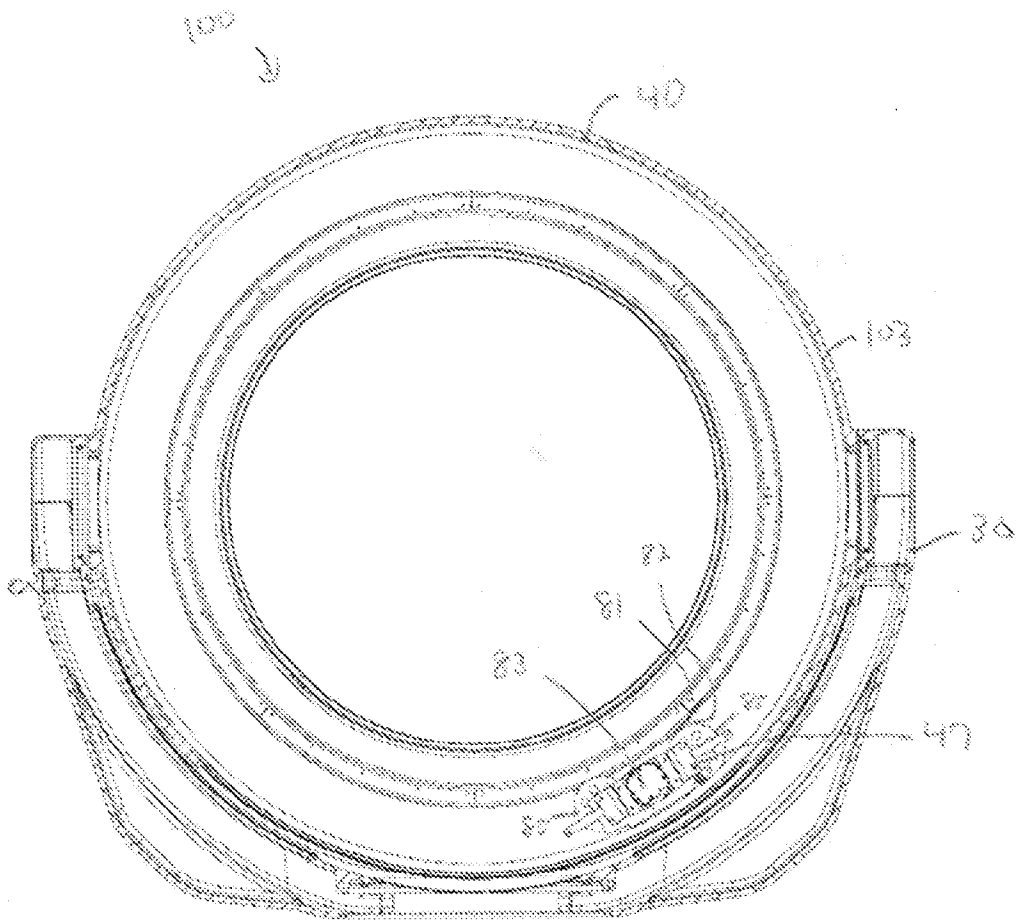

FIG. 16

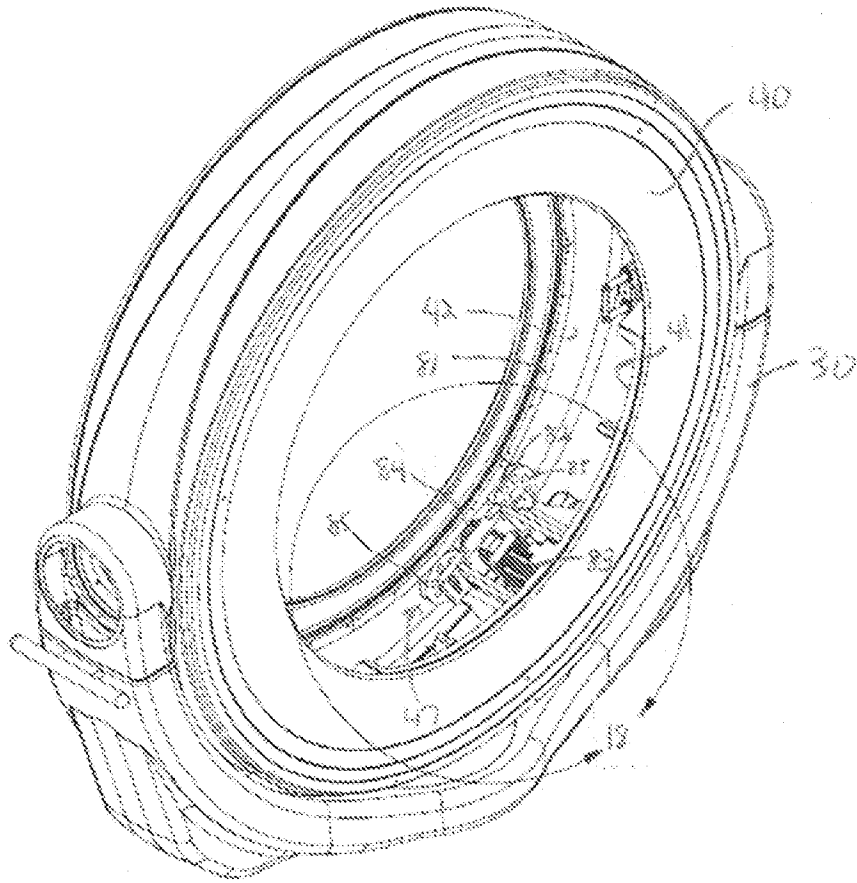

FIG. 17

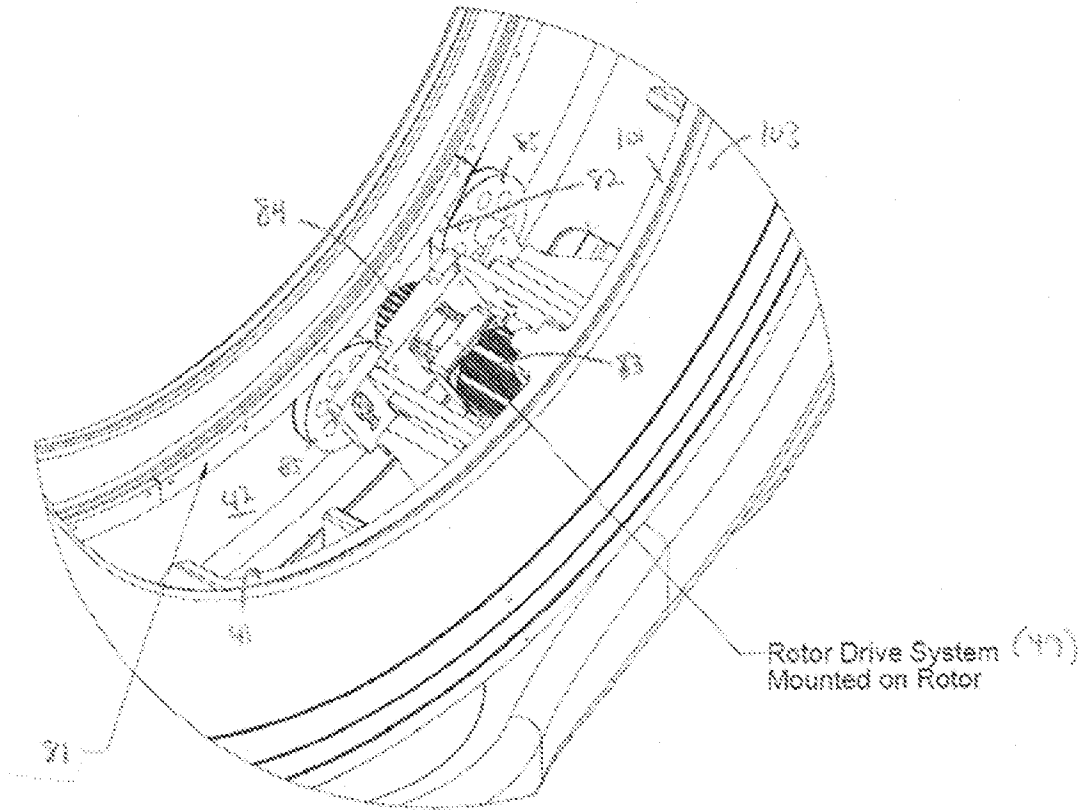

FIG. 18

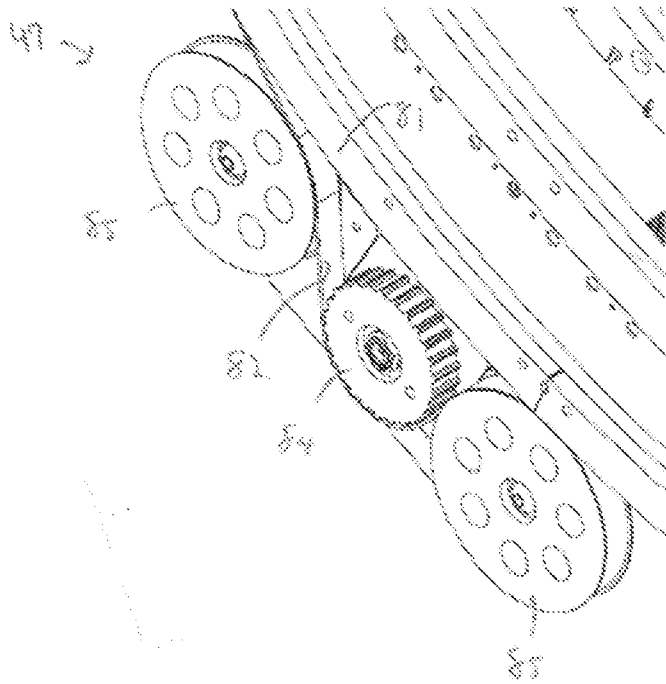

FIG. 19