

E. E. FLORA.  
 SEALING MEANS FOR BOXES.  
 APPLICATION FILED JUNE 16, 1910.

996,918.

Patented July 4, 1911.

*Fig. 1.*

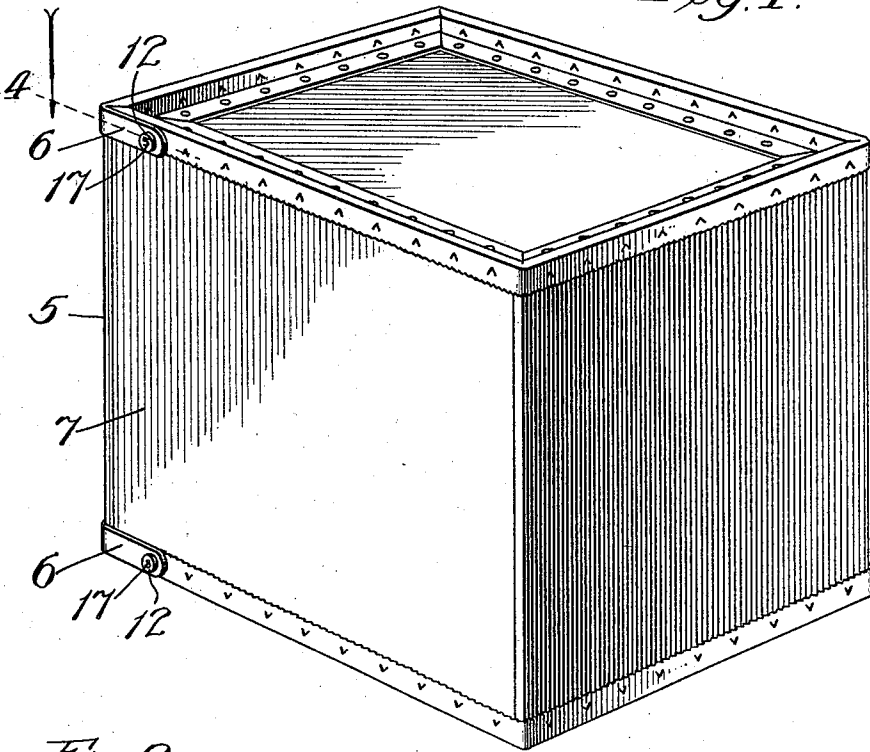

*Fig. 2.*

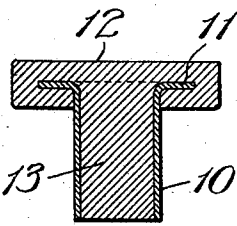

*Fig. 4.*

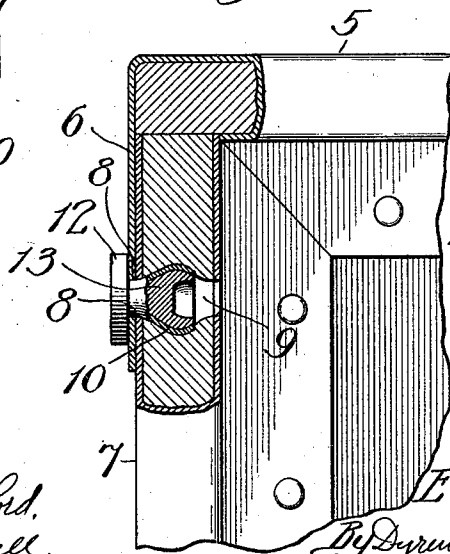

*Fig. 3.*

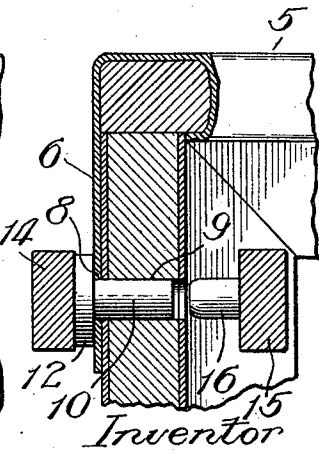

Witnesses:

*Ed. D. Byford,*  
*Chas. H. Buell.*

Inventor

*Ellsworth E. Flora.*

*By Dyruporth, Lee, Christon & Miles,*  
*Attys.*

# UNITED STATES PATENT OFFICE.

ELLSWORTH E. FLORA, OF CHICAGO, ILLINOIS, ASSIGNOR TO SIMPLEX METAL BOUND BOX COMPANY, OF CHICAGO, ILLINOIS, A CORPORATION OF NEW JERSEY.

## SEALING MEANS FOR BOXES.

996,918.

Specification of Letters Patent.

Patented July 4, 1911.

Application filed June 15, 1910. Serial No. 566,945.

To all whom it may concern:

Be it known that I, ELLSWORTH E. FLORA, a citizen of the United States, residing at Chicago, in the county of Cook and State of Illinois, have invented a new and useful Improvement in Sealing Means for Boxes, of which the following is a specification.

My object is to provide a simple, novel and inexpensive method of and device for fastening down and sealing, more especially, the projecting tongues of metal-bound boxes of the general type shown in Reissue Patent No. 12800, granted to me May 26, 1908. The body of a box of this type is formed of sheets of box-stock bound and fastened together with metal strips having trough-sections, which incase the edges of said sheets, flanges forming abutments for inset box ends, and projecting tongues on the strips for fastening down the box cover.

In the drawing—Figure 1 is a perspective view of a metal-bound box of the type defined, with seals applied to fasten down the cover; Fig. 2, a sectional view of my improved seal; Fig. 3, a fragmentary view illustrating the way the seal is applied; and Fig. 4, an enlarged section on line 4 in Fig. 1 showing a seal in place.

When the box-cover 5 is closed, each of its projecting tongues 6 is bent to extend along the adjacent metal-bound side edge of the box front 7, and the two are punched to form a sealing opening 8 through the tongue and a sealing opening 9 coincident therewith, through the box-stock and its metal binding-strip.

The improved seal is formed with a shell which is of brass, or other suitable, relatively hard material, having a flange 11 incased in a disk of lead, or other suitable, relatively soft metal forming the sealing-head 12. The shell, or hollow shank, 10 is provided with a filler 13 of the said comparatively soft metal. The openings 8, 9 should be of a diameter to barely admit the shank of the seal, and the latter should be of a length slightly less than that of the openings. The seal is placed in position by passing it through the opening 8 and partway

through the opening 9, as shown in Fig. 3. It is then subjected to pressure by means of a suitable tool having a head-engaging jaw 14 and a jaw 15 equipped with a slightly tapering pin 16. As the jaws are pressed in the direction of each other a suitable die or matrix (not shown) on the jaw 14 may form a private character 17 upon the surface of the sealing-head 12 and the pin embeds itself in the metal filler 13 to swell the same and expand the shank 10 circumferentially into the box-stock between the surfaces of the latter within the binding-strip. The expanding of the shank causes it to form an annular shoulder so embedded in the wall of the box-stock opening 9 as to produce a secure fastening means for the seal which, in consequence, cannot be extracted and replaced in a manner to defy ready detection, without the employment of so much skill and time as to render the attempt, by anyone under the necessity of disguising the fact, very unlikely.

My improved seal may be modified in the matter of details of construction without departing from the spirit of my invention as defined by the claim.

What I claim as new and desire to secure by Letters Patent is—

In a metal-bound box, the combination with a body portion formed of box-stock, of metal binding strips having trough-shaped sections in which the end-portions of the box-stock are contained, and means for securing and sealing the binding strip to the said contained end portions comprising a seal having an enlarged head, a hollow shank of relatively hard metal, and a filler in the shank of relatively soft metal, the shank passing through one side of the trough-section of the binding strip and partway through said box-stock, the filler and shank being expanded to indent the latter circumferentially between its ends into the box-stock.

ELLSWORTH E. FLORA.

In presence of—

L. HEISLAR,  
R. SCHAEFER.