

(No Model.)

5 Sheets—Sheet 1.

E. SMITH.  
SEWING MACHINE.

No. 504,792.

Patented Sept. 12, 1893.

*Fig. 1.*

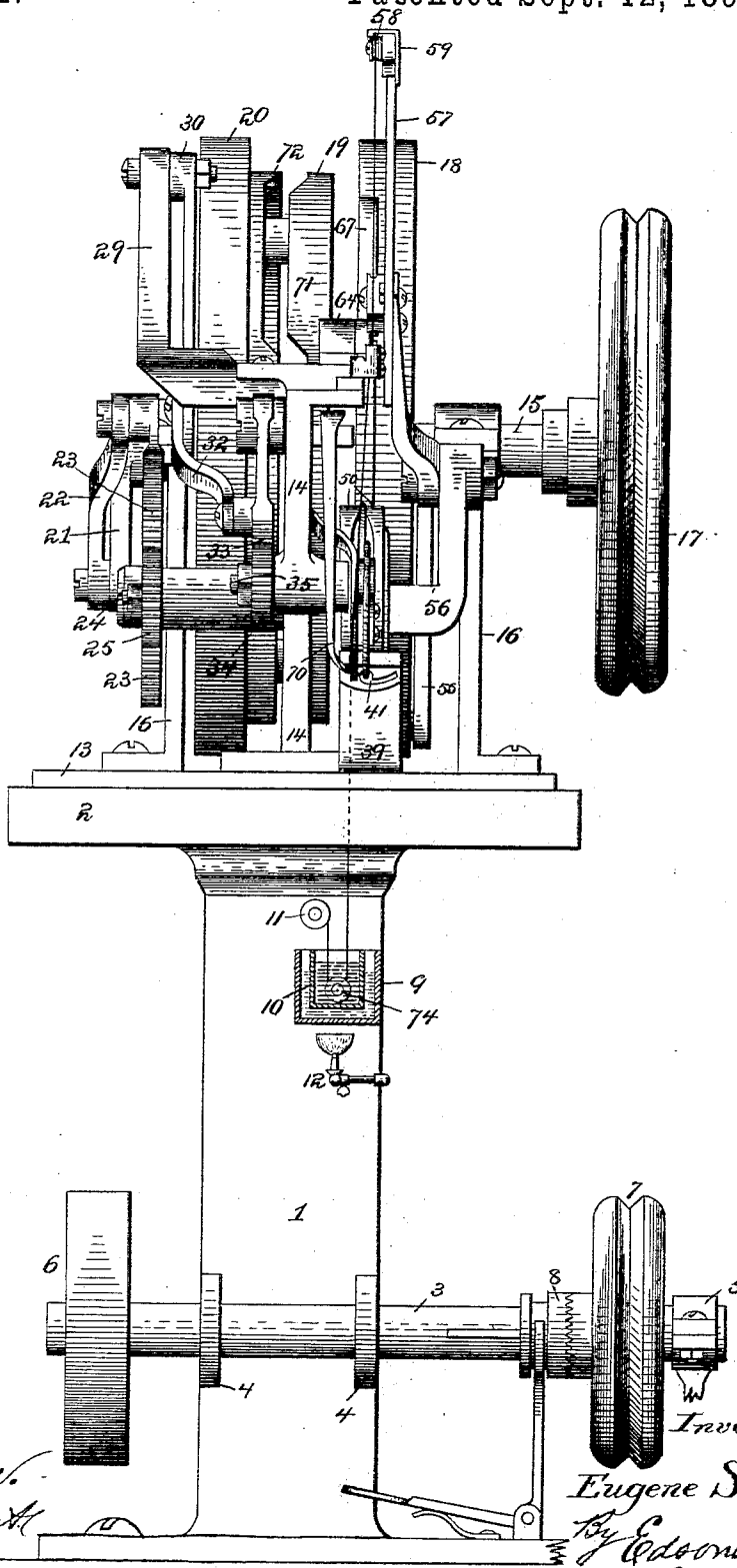

Witnesses:  
*J. B. McJannet*  
*Arthur L. Bryant*

Inventor:  
*Eugene Smith*  
 By *Edson Bros.*  
*Lio Atty.*

(No Model.)

5 Sheets—Sheet 2.

E. SMITH.  
SEWING MACHINE.

No. 504,792.

Patented Sept. 12, 1893.

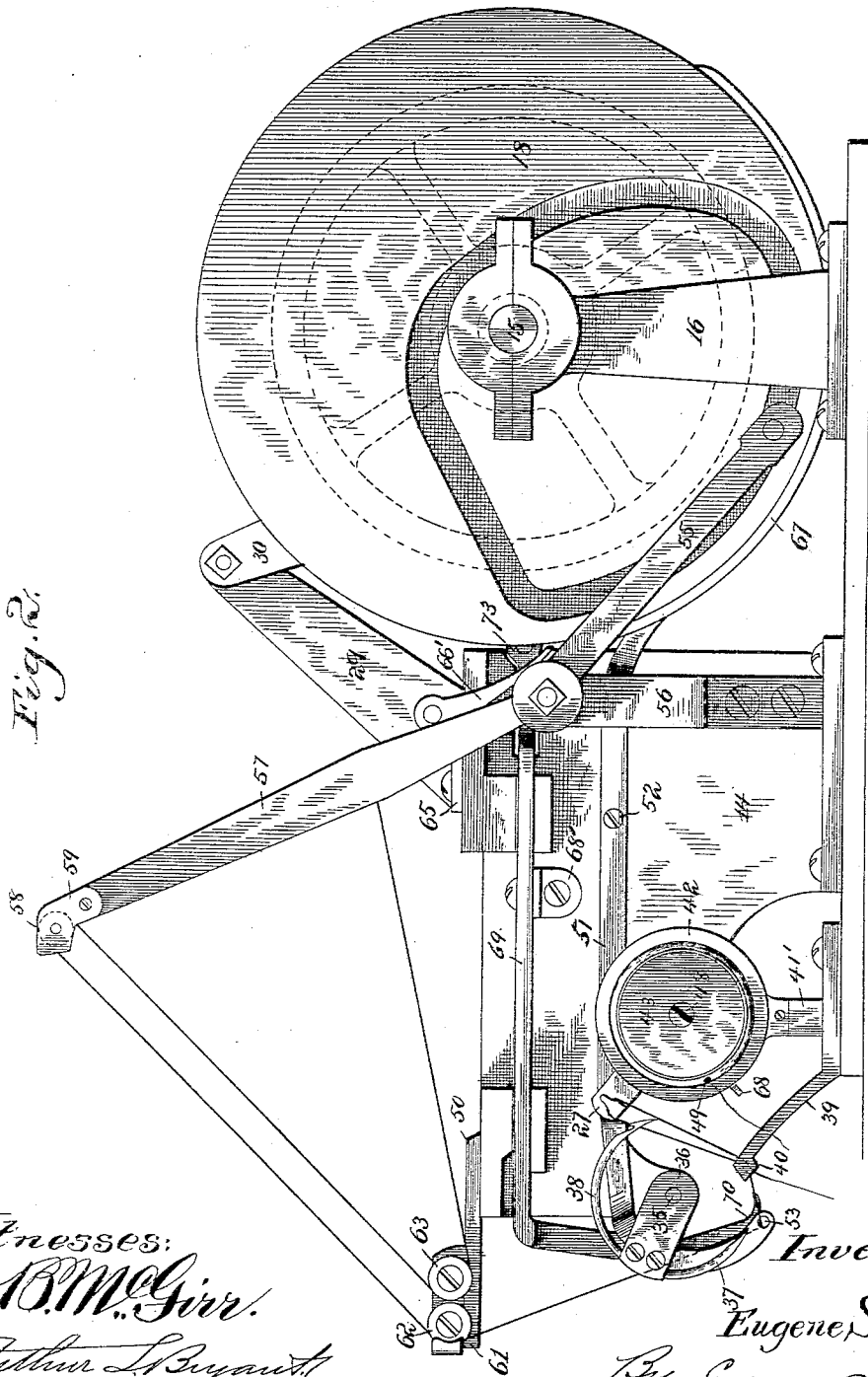

*Fig. 2.*

Witnesses:  
*J. B. McGinn*  
*Arthur L. Bryant*

Inventor,  
*Eugene Smith*  
By *Edson Bros,*  
*his Atty.*

(No Model.)

5 Sheets—Sheet 3.

E. SMITH.  
SEWING MACHINE.

No. 504,792.

Patented Sept. 12, 1893.

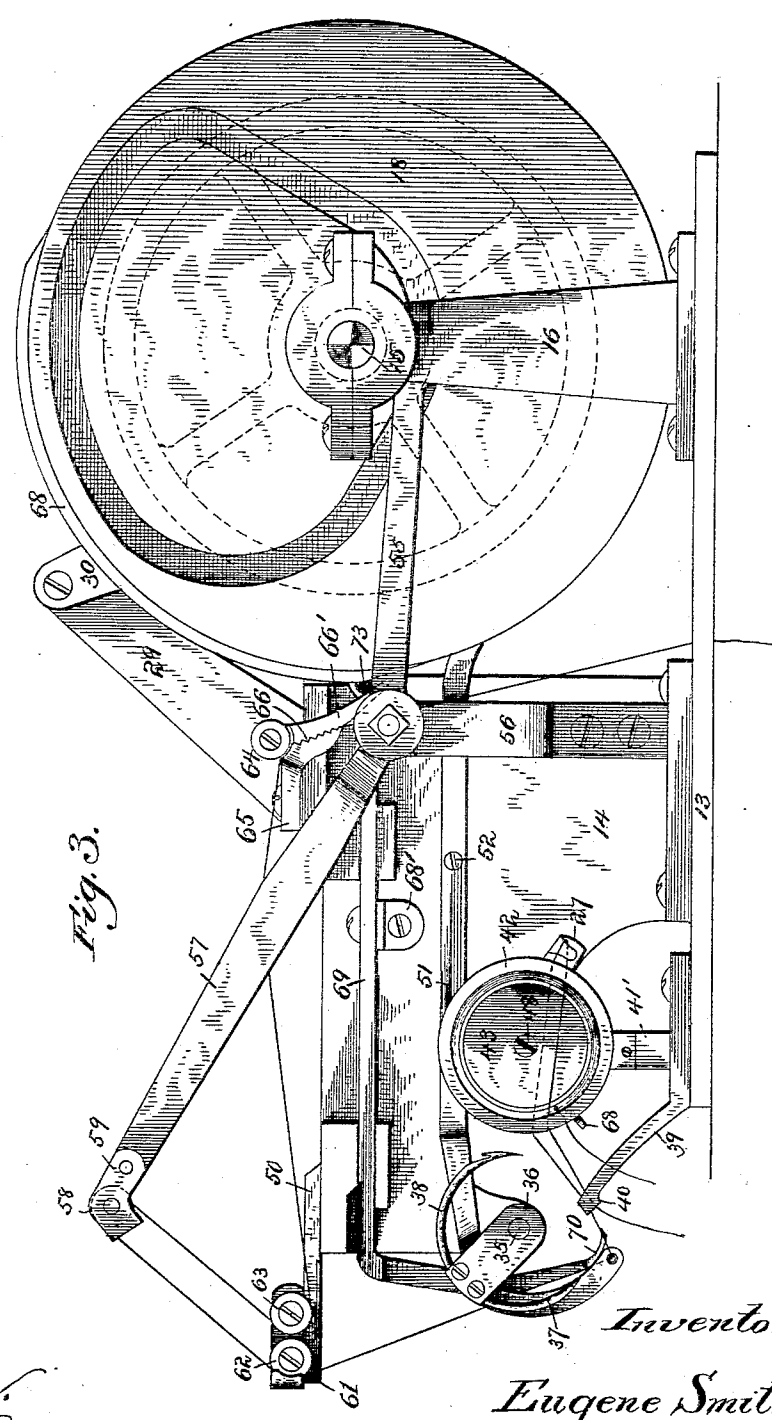
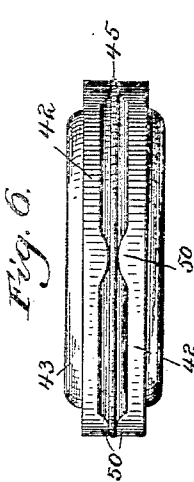
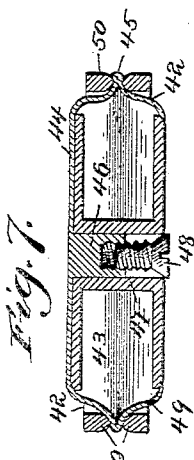

Witnesses:  
*J. B. McGinnis*  
*Arthur L. Bayant*

Inventor:  
*Eugene Smith*  
 By *Edoon Bros*,  
*his Attys.*

(No Model.)

5 Sheets—Sheet 4.

E. SMITH.  
SEWING MACHINE.

No. 504,792.

Patented Sept. 12, 1893.

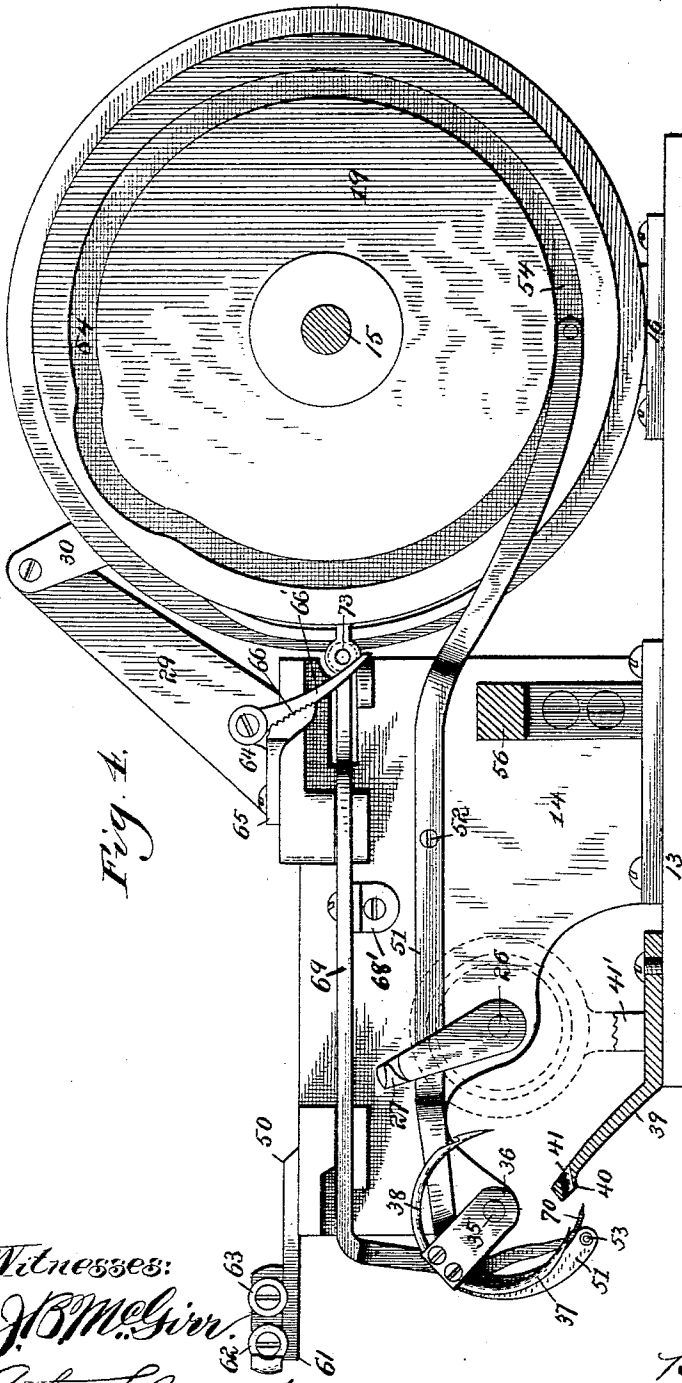

Fig. 1.

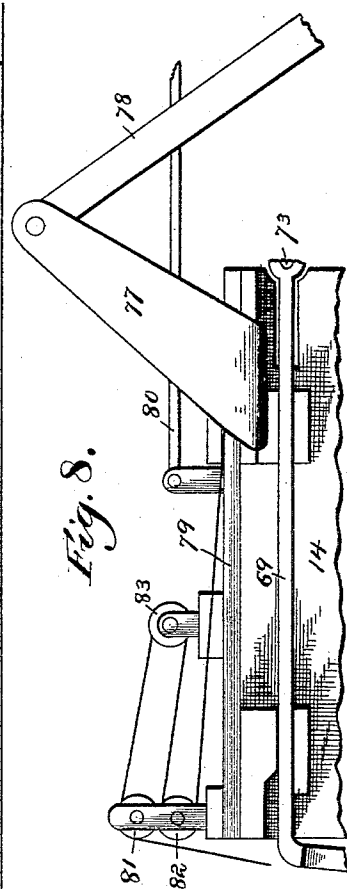

Fig. 8.

Witnesses:

J. M. Ginn  
Arthur L. Bryant

Inventor:

Eugene Smith.  
By Edmond B. Smith,  
his Attys.

(No Model.)

5 Sheets—Sheet 5.

E. SMITH.  
SEWING MACHINE.

No. 504,792.

Patented Sept. 12, 1893.

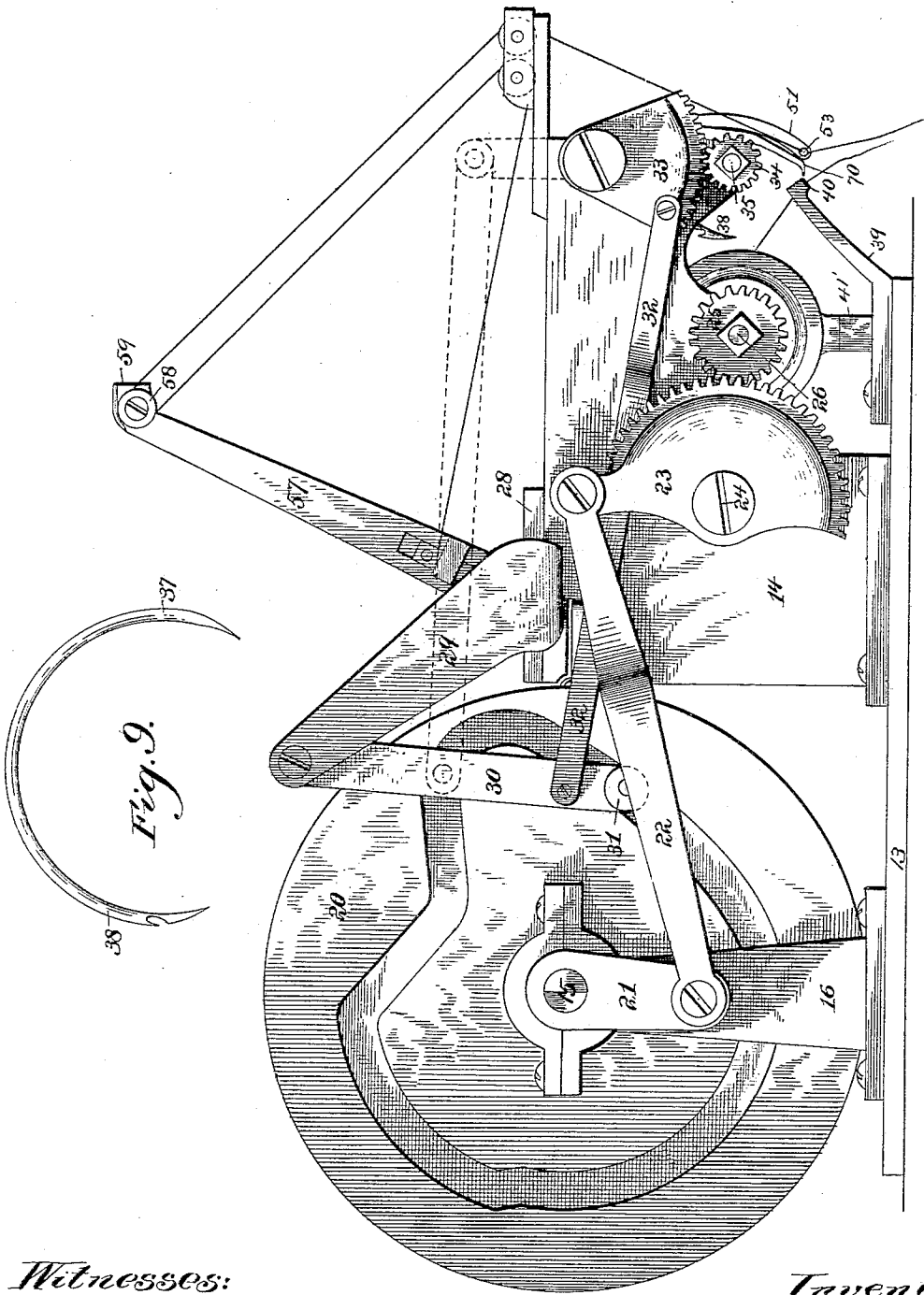

Witnesses:  
*J. B. McGinn.*  
*Arthur L. Bryant.*

*Fig. 5.*

Inventor:  
*Eugene Smith.*  
 By *Edson Bros.,*  
*his Atty.*

# UNITED STATES PATENT OFFICE.

EUGENE SMITH, OF PHILADELPHIA, PENNSYLVANIA.

## SEWING-MACHINE.

SPECIFICATION forming part of Letters Patent No. 504,792, dated September 12, 1893.

Application filed January 26, 1892. Serial No. 419,291. (No model.)

*To all whom it may concern:*

Be it known that I, EUGENE SMITH, a citizen of the United States, residing at Philadelphia, in the county of Philadelphia and State of Pennsylvania, have invented certain new and useful Improvements in Boot or Shoe Sewing Machines; and I do hereby declare the following to be a full, clear, and exact description of the invention, such as will enable others skilled in the art to which it appertains to make and use the same.

My invention relates to improvements in lock stitch wax thread sewing machines especially designed for sewing the in seams of boots or shoes; and the invention consists in the novel combination of devices and peculiar construction and arrangement of parts as will be hereinafter fully described and claimed.

In the accompanying drawings—Figure 1 is a front elevation of a machine embodying my invention. Fig. 2 is a side elevation of the machine removed from its standard or support showing the take up bar in its elevated position. Fig. 3 is a similar view showing the take up bar lowered. Fig. 4 is a similar view partially in section, with the driving wheel, take up mechanism and bobbin-case removed. Fig. 5 is an elevation of the other side of the machine. Fig. 6 is a top plan view of the bobbin case. Fig. 7 is a sectional view of the same. Fig. 8 is a detailed view of a modified form of take up mechanism; and Fig. 9 is a detail view of a modified form of needle.

Like numerals of reference denote corresponding parts in all the figures of the drawings, referring to which—

1, designates a pillar or standard which is suitably attached to the floor or ground and is provided with a top 2 to which the machine proper is secured. A shaft 3 is journaled in suitable bearings 4 on the pillar 1, and an upright or standard 5. A driving pulley 6 is rigidly attached to the shaft 3 near one end, and on said shaft, near the other end, is loosely fitted a band wheel 7 which is adapted to be rigidly fastened to the shaft, so as to rotate therewith when the driving pulley 6 is revolved, by the clutch mechanism 8.

To one side of the pillar or support 1, is attached a vessel or tank 9, and within this vessel is arranged another and smaller vessel 10. A supply spool 11 is suitably attached to the

pillar 1 above the vessel 9, and below said vessel is arranged a gas jet 12 or other source of heat.

To the top 2 is attached in any suitable manner a base plate 13 on which is mounted the main frame 14 of the machine.

A driving shaft 15 is journaled in suitable bearings 16 attached to the base plate and on one end of this shaft is secured a band wheel 17 adapted to be connected, by a suitable band, with the band wheel 17 on the shaft 3. On the driving shaft 15, between the bearings thereof, are mounted three parallel cam disks or plates 18, 19 and 20.

As before stated, the band wheel 17 is attached to one end of the driving shaft 15 and to the opposite end of said shaft is attached a crank 21. The free end of this crank 21 is connected to one end of a connecting rod 22, the other end of which is attached to a segment gear 23. The segment gear 23 is carried by a shaft 24 which is fitted in a suitable bearing on the main frame 14 of the machine; and said gear 23 meshes with a pinion or gear 25 attached to one end of a shaft 26. The shaft 26 extends through the frame 14 of the machine and to the other end of said shaft is attached a loop carrying hook 27.

To the upper side of the frame 14 is secured a plate 28 which is provided at one edge with an upward and rearwardly extending arm 29. To the upper free end of this arm is pivotally attached a depending bar 30, and to this bar, near the lower free end thereof, is attached a roller 31 which rides or fits in an irregular cam groove formed in the outer face of the disk or plate 20. A connecting rod or link 32 has one end connected to the bar 30 near the lower end thereof, and its other end is attached to a segment gear 33 which is suitably mounted on the frame 14 and meshes with a pinion 34 carried by a shaft 35.

To the opposite end of the shaft 35 is secured the awl and needle clamp 36, which clamp has its outer end bifurcated to receive the awl 37 and needle 38. I, preferably, make the awl and needle from a single piece of steel wire of the desired size and, as shown, this combined awl and needle is fitted at an intermediate point of its length in the bifurcated end of the clamp 36, the distance from the plate 36 to the end of the awl being less

than the distance from the same point to the eye of the needle.

Near the forward end of the base plate 13 is attached an angular plate 39, having the free end extending upwardly and projecting beyond the front end of the base plate to form a work rest 40. An aperture 41 is formed in the plate 39 near its upper end, and through said aperture the awl 37 and needle 38 are adapted to be alternately oscillated as will be hereinafter fully described. A short upwardly extending stud 41' is rigidly attached to or made integral with the plate 39, and to this stud are suitably attached two parallel rings 42 between which is fitted the bobbin-case. This bobbin case consists of a hollow shell or case 44 which is open on one face and is provided on its periphery with a central annular rib 45. A hollow divided and internally threaded spindle 46 is attached to the rear wall of the case or shell 44 and around this spindle is fitted a thread spool 47. A cone screw 48 is adapted to be screwed into the outer end of the spindle 46 to force the sections thereof against the thread spool and thus regulate the tension of the thread. An aperture 49 is provided in the wall of the shell or case 44 through which the thread passes after leaving the spool 47.

The parallel rings 42 are provided at intermediate points with projecting lugs or flanges 50 which contact with the annular rib 45 on the periphery of the shell or case 44 and thus operate to keep the bobbin case in position. To one of the rings 42 is attached a spring arm 68 which extends across the periphery of the bobbin-case and bobbin and the other ring 42.

51 designates the looper bar which is pivotally connected to the frame 14 at 52, and has its forward end curved and extending substantially parallel to the curved awl 37. An eye 53 is formed in the curved portion of the looper bar near the end thereof. A suitable roller is attached to the bar 51 near its inner end and this roller rides in a cam groove or recess 54 formed in one face of the disk 19. A lever 55 is fulcrumed on a brace 56 attached to the frame 14, and this lever, has a suitable friction roller near its inner end which roller fits in a cam groove 18' formed in the outer face of the disk 18.

By reference to Fig. 3 of the drawings it will be seen that the cam groove 18' is for a portion of its length concentric with the driving shaft on which the disk 18 is secured and that the other portions of said cam groove are eccentric to said shaft.

To the lever 55, near its upper free end, is adjustably connected an arm 57 which is provided near its upper end with a guide wheel or pulley 58. A cap or cover 59 is pivoted to the arm 57 and extends partially over the pulley 58. The frame 14 is provided at its forward end with a laterally projecting flange 50 and to this flange is connected a short arm

61 provided near one end with two guide wheels or pulleys 62, 63, respectively.

A thread clamp 64 is attached to the frame 14 and this clamp consists of a fixed or stationary member 65, provided with a depending portion 66, one face of which is roughened, and with a pivoted member 66' which has a portion of its inner face roughened to correspond to the roughened face of the stationary member. The rear end of the pivoted member of the clamp lies in the path of and is adapted to be operated by a cam 67 on the periphery of the disk 18.

To a lug 68' on the frame 14 is pivotally connected a feed lever 69 the forward end of which is bent downwardly and is provided at its lower end with a spur or brad 70 which spur lies in a plane slightly below the upper surface of the work rest 40. The lever 69 is provided with a longitudinal slot through which the pivot by which it is attached to the lug 68', passes. The lever 69 extends rearwardly between the disks 19, 20, which are provided on their adjacent faces with irregular annular cams 71, 72, respectively; and the lever 69 is, preferably, provided with a pair of guide rollers between which the cam 72 on the disk 20 passes. (Only one of these guide rollers 73 is shown.) The cam 72 is made of varying thickness so that as the lever 69 is oscillated on its pivot it will also be given at every revolution of the disk 20, a slight longitudinal movement.

The operation of my invention, is as follows:—The vessel 10 is partially filled with wax and the exterior vessel 9 with water. The gas jet is lighted to heat the water in the vessel 9 and melt the wax. The thread 75 from the supply spool 11 is fed down through the wax in the vessel 10 and around a pulley 74 suitably journaled in said vessel. The thread passes up through a suitable aperture in the base or bed plate 13, between the members of the clamp 64, around the guide pulley 63, the pulley on the arm 57, the pulley 62 and through the eye 53 in the looper bar. The other thread 76 runs from the shuttle through the aperture in the work rest 40. Motion is communicated to the shaft 3 and by adjusting the clutch mechanism 8 the band wheels 7, 17, and shaft 15 with its attached disks 18, 19, 20, are rotated. The shaft 35 is operated on by the segment gear 33 to oscillate the needle clamp and cause the awl 37 and needle to alternately pass through the work held against the rest 40 and the aperture therein. It will be noticed that the awl first passes through the work and then through the aperture in the work rest and that the needle enters the aperture in the work rest from the opposite side from which the awl entered. As the needle starts back through the work and rest 40, the forward end of the looper bar is elevated slightly to force the thread carried thereby into the barb of the needle so that on its backward stroke the needle carries a

loop of thread 75 through the work. While the awl is moving through the work, the guide roller on the arm 55 is in that portion of the cam groove 18' which is concentric with the driving shaft and the take up lever is therefore not affected by the movement of the disk 18. As the needle leaves the aperture in the work rest, the clamp 64 is freed from contact with the cam on the periphery of the disk 18 and at the same time the guide roller on the arm 55 passes into one of the sections of the cam groove 18' that is eccentric to the driving shaft and the free end of the take up bar 57 begins to descend, thus allowing the needle to draw the thread through the work and rest. When the needle reaches the position shown in Fig. 2, the loop carrying hook 27 takes the loop from the needle and carries the same around the bobbin-case and bobbin, the thread being divided by the peripheral rib on the bobbin-case. The take up continues to descend until the loop has reached the side of the bobbin-case opposite the work rest when the guide roller on the arm 55 passes into the other section of the cam groove 18' that is eccentric to the driving shaft and the take up begins to ascend and the cam on the periphery of the disk 18 operates on the clamp 64 to prevent any more thread passing through said clamp. The upward movement of the take up bar draws the loop around the under side of the bobbin-case and said loop surrounds the thread 76 from the bobbin and draws such loop after it through the rest 40 and the work, thus making a lock stitch. As soon as the stitch has been formed the feed lever 69 is moved laterally and, as the spur on the lower end thereof engages with the work, the work is moved the proper distance to allow the awl at its next forward stroke to pierce the same the proper distance from the stitch last formed. As soon as the work has been moved the proper distance and as the awl enters the same, the feed lever is moved forward slightly to disengage the spur 70 and is then moved back to its normal position.

In Fig. 8, I have illustrated a modified form of take up mechanism. In this construction I move the take up mechanism hereinbefore described and attach to the frame 14 an inclined arm 77 similar to the arm 29 on the other side of the machine. To this arm 77 is attached a depending bar 78 which is provided with a suitable roller adapted to ride in the cam groove in the outer face of the disk 18. A horizontal bar 79 is guided in suitable ways on the frame 14 and this bar is provided with an upwardly extending lug which is connected, by a link 80, with the bar 78. On a suitable upright or standard secured to the frame of the machine near the forward end thereof are mounted two guide rollers 81, 82; and a similar roller 83 is arranged on the bar

79 in rear of the rollers 81, 82. In this modification the bar 79 is moved forward to allow the thread to become slack as the needle draws the loop through the work and the work rest 40.

In Fig. 9 I have illustrated a modified construction of needle in which the barb or eye opens toward the point thereof. When using this form of needle I would attach one end of the link 32 higher up on the bar 30 and connect the other end of said link to an upwardly extending arm on the segment gear 33 shown in dotted lines in Fig. 5 in order to reverse the movement of the said gear and the movement of the needle and awl. In this construction the awl first passes through the aperture in the work rest 40 and then through the work; while the needle enters the work from the seam side and pushes the loop of thread through the work and the work rest until it is grasped by the loop carrying hook and carried around the bobbin case.

I am aware that changes in the form and proportion of parts and details of construction of the devices herein shown and described, as an embodiment of my invention, can be made without departing from the spirit or sacrificing the advantages thereof; and I, therefore, reserve the right to make such changes and alterations as fairly fall within the scope of my invention.

Having thus fully described my improvements, what I claim as new, and desire to secure by Letters Patent, is—

1. The combination of a needle, a looper bar, the stationary concentric rings provided on their inner faces with a series of coincident projections, a bobbin case provided with an annular rib which fits between the projections on said rings, and a loop carrying hook adapted to be oscillated about the bobbin-case, substantially as described.

2. The bobbin case herein shown and described, consisting of a hollow case open at one side and provided with a hollow divided threaded spindle, a thread spool fitted on the hollow spindle, and a cone screw adapted to be screwed into the hollow spindle, substantially as described.

3. The combination of a needle, a looper bar, the stationary parallel rings, a bobbin case arranged between the rings and provided with a hollow divided spindle, a thread spool mounted on said spindle, a cone screw adapted to be screwed into the divided spindle and a loop carrying hook adapted to be oscillated about the bobbin case, substantially as described.

In testimony whereof I affix my signature in presence of two witnesses.

EUGENE SMITH.

Witnesses:

THOMAS OWENS,  
WM. COLGAN.