



(12) **EUROPEAN PATENT APPLICATION**

(43) Date of publication:
17.12.2008 Bulletin 2008/51

(51) Int Cl.:
A43C 11/14 (2006.01)

(21) Application number: **07425372.5**

(22) Date of filing: **14.06.2007**

(84) Designated Contracting States:
AT BE BG CH CY CZ DE DK EE ES FI FR GB GR HU IE IS IT LI LT LU LV MC MT NL PL PT RO SE SI SK TR
 Designated Extension States:
AL BA HR MK RS

(72) Inventor: **Chenet, Antonio**
31030 Covolo di Pederobba (IT)

(74) Representative: **Agostini, Agostino et al**
Dragotti & Associati srl
Via Paris Bordone 9
31100 Treviso (IT)

(71) Applicant: **Chenet, Antonio**
31030 Covolo di Pederobba (IT)

(54) **Blocking device**

(57) Blocking device (1; 101) with two rack elements that have toothings arranged in cooperation to hold a blocking pin (50). The first rack element (5; 105) is mounted so that it is mobile with respect to the second rack element (3; 103), so that the toothings of the rack elements

(3; 5; 103, 105) can take up a first configuration in which they hold a blocking pin (50) and a second configuration in which they release it.

The blocking pin is prevented from slipping out accidentally.

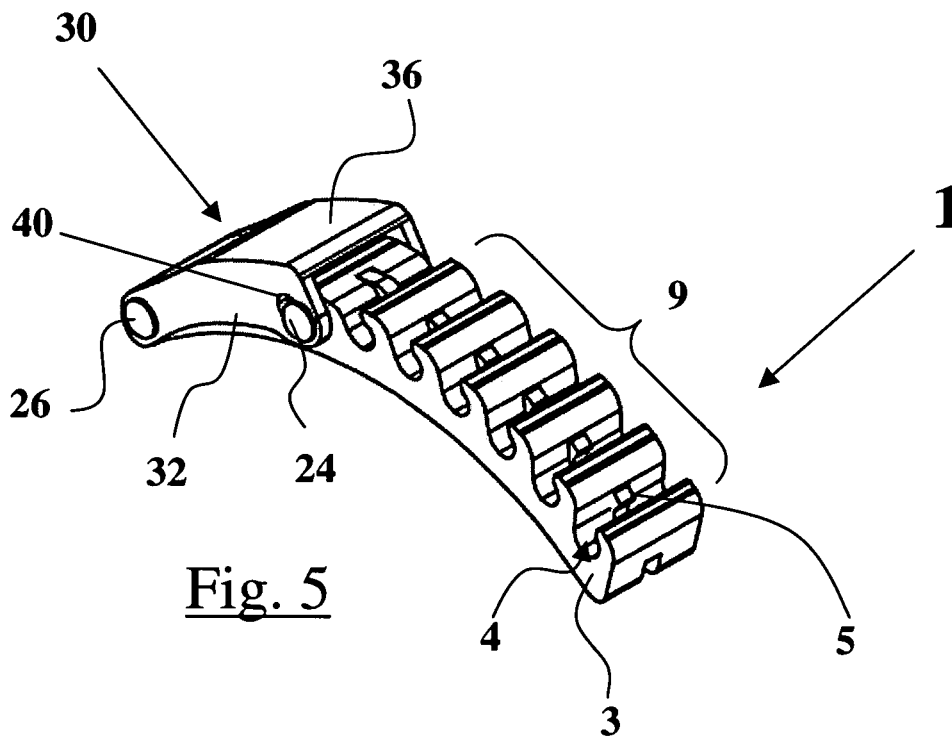

Fig. 5

Description

[0001] The invention concerns a blocking device, in particular for ski boots to which the following description shall refer as an example.

[0002] Known closing/blocking devices for ski boots comprise elements mounted on two opposite flaps of an opening and cooperating with one another. An example is described in European patent EP 0663155 in which a fastening device comprises, on one side, a lever element with a transversal pin, and on the other side a rigid rack with a longitudinal cavity wherein a deformable inner rack is arranged. The two racks have the teeth staggered with respect to each other. When the boot is being opened and closed the pin of the shaft can elastically deform a tooth of the inner rack, so that to fasten to the rigid rack the user must necessarily exert a force on the pin to deform it. In this way, this device allows accidental detachments, even if it has some drawbacks: it is not completely sure that it will remain closed in the case of collisions and, when the boot is being opened and closed, the toothing of the elastic rack is subject to continuous deformations, tending to wear down over time and so becoming ineffective.

[0003] The object of the invention is to provide a more efficient blocking device, which allows the aforementioned problems to be solved. Such an object is accomplished by a closing device comprising a first rack element and a second rack element with toothings arranged in cooperation to hold a blocking pin, characterised in that the first rack element is mounted so that it is mobile with respect to the second rack element, so that the toothings of the rack elements can take up a first configuration wherein they hold the blocking pin and a second configuration wherein they release it.

[0004] The invention achieves the important advantage of allowing, when the boot is being opened and closed, the insertion and removal of the pin from a recess between the toothings without any deformation of them, in this way avoiding wearing down of the teeth or of the pin involved, and thus allowing closing that is more secure over time.

[0005] In the device preferably one of the rack elements is mounted so that it can translate with respect to the other, however also being able to exploit a relative rotation, for example.

[0006] The second rack element can comprise a longitudinal cavity in which the other rack element is mounted so that it can translate, so that the rack elements have the respective toothings side-by-side. It is also possible, however, to have side-by-side assembly.

[0007] Advantageously, the device can comprise elastic means to polarise one or both of the rack elements in the first configuration.

[0008] Advantageously, the device can comprise a mechanism for taking the first rack element into the second configuration overcoming the polarisation of the elastic means. Such a mechanism preferably comprises an

actuation surface by pressing which the first rack element can be taken into the second configuration overcoming the polarisation of the elastic means. The actuation surface, with a simple preferred embodiment, forms part of a button that is hinged onto the first rack element so as to be able to oscillate and is connected to the second rack element through a pin, firmly connected to one of the two, which can slide along the inclined edges of a seat formed in the other.

[0009] The characteristics and the further advantages of the invention shall become clear from the description of example embodiments with reference to the attached drawings, where

figure 1 represents a vertical section of a blocking device in a first operative configuration;

figure 2 represents a side view of the device of figure 1;

figure 3 represents a view of the device of figure 1 in a second operative configuration;

figures 4 and 5 represent two axonometric views of the device of figure 2 and 3;

figure 6 represents an exploded view of the device of figures 1 to 5;

figure 7 represents a side view of a variant of an element of the device;

figure 8 is an axonometric view of the element of figure 7;

figure 9 represents a side view of a variant of the device;

figure 10 represents a vertical section of the device of figure 9;

figure 11 represents a plan view of the device of figure 9;

figure 12 represents an exploded view of the device of figure 9;

figure 13 represents an axonometric view of the device of figure 10 assembled.

[0010] With reference in particular to figures 1 and 2, a first blocking device 1 is shown, which can be fixed to a flap of an opening of a boot, which cooperates, by means of a blocking pin 50, with a fastening device (not shown in the figures) fixed to another flap of the opening of the boot.

[0011] The blocking device 1 comprises a first fixed rack 3, preferably made of aluminium and equipped with a longitudinal cavity 7 (figure 6), in which a second mobile rack 5, preferably made of hardened steel, is housed (figures 4, 5 and 6). The racks 3, 5 are toothed and define recesses 4 intended to contain the blocking pin 50 in different fastening positions. The racks 3, 5 are preferably curved and have the same bending radius at the respective toothings.

[0012] The first rack 3 comprises a smooth portion 6 and a toothed portion 9 (figure 6); some transversal through holes 12, 14 are formed. The through hole 12 has an elongated section, preferably elliptical. A third

through hole 16, with axis substantially perpendicular to that of the through holes 12 and 14, is formed in the first smooth portion 6.

[0013] The longitudinal cavity 7, which extends for the totality of the toothed portion 9 and for part of the smooth portion 6, houses the second rack 5, in turn comprising a toothing 18 adjacent to a smooth portion 20; in the latter a through hole 22 is obtained.

[0014] The teeth of the two racks 3, 5 are arranged side-by-side and they each have a different number: six for the rack 3 and five for the rack 5. Therefore, an end tooth of the rack 3 is not side-by-side with any tooth of the second rack 5 (figure 1). In this way such an end tooth defines a recess 4 in which the blocking pin 50 can insert freely without opposition, both going in and coming out.

[0015] The first rack 5 is constrained to the first rack 3 through an attachment pin 24 (figures 1-3 and 6) with circular section slotted into the holes 12, 22.

[0016] The (circular) section of the attachment pin 24 is less than and can be contained within that (slop or elliptical shaped) of the through hole 12 and this allows the pin 24 to translate inside the hole 12, in a direction roughly parallel to the toothings of the racks 3, 5, pulling the rack 5 into rotation with it.

[0017] The blocking device 1 also comprises a pressing element 30, preferably a metallic slab that offers a flat upper actuation surface, shown in figure 6. It has two slightly curved shoulders 32 and 34, arranged parallel to one another, and a flat joining portion 36 that extends roughly perpendicular between two of their ends.

[0018] On the opposite ends of the shoulders 32, 34 some through holes 38, 40 and through holes 42, 44 are respectively obtained, the holes 38, 42 having a circular section and the holes 40, 44 having elongated section, preferably elliptical, with the larger axis inclined with respect to the curvature of the rack 3. In this way the holes 40, 44 behave towards the pin 34 like inclined planes, which move it back and forth when the element 30 goes up and down.

[0019] The pressing element or button 30 is mounted hinged to the rack 3 at the smooth portion 6 by means of a pin 26 that partially engages the hole 38, the hole 14 and the hole 42. The shoulders 32, 34 are arranged parallel to, and straddling, the rack 3.

[0020] The pin 24 engages the hole 40, the hole 12, the hole 22 and the hole 44. In this way the pressing element 30 can oscillate about the pin 26 by an angle defined by the clearance between the pin 24 and the holes 40, 44. Indeed, the pin 24 can translate inside the holes 40, 44 whereas it cannot translate inside the hole 22, consequently pulling the rack 5 into translation.

[0021] The device 1 can be fixed to a flap of the opening of the boot through a rivet that passes through the hole 16.

[0022] On the surface of the smooth portion 6 there is a further cavity 27, with axis substantially perpendicular to the curvature of the rack, which houses a spring 28. The spring 28 is in abutment at the top with the pressing element 30 and at the bottom on the base of the cavity

27, and it can be compressed following the element 30 being pressed.

[0023] The operation of the device 1 shall now be described.

5 **[0024]** After having put on the boot, the user takes the fastening device equipped with the blocking pin 50 up to the blocking device 1 so as to be able to insert the blocking pin 50 into a recess 4.

10 **[0025]** In rest position the spring 28 acts from below on the flat portion 36 to keep the pressing element 30 in maximum lift position with respect to the rack 3 (figure 2).

[0026] The mobile pin 24 is, consequently, at the lower end of the holes 40, 44 and, with respect to the rack 3, moved by the maximum amount towards its centre. For the coupling between the pin 24 and the rack 5, it is also moved by the maximum amount towards the toothed portion 9. In this first configuration the two racks 3, 5 have the respective toothed profile misaligned by the maximum amount, and this does not allow the blocking pin 50 to engage any recess 4.

20 **[0027]** At the time when the user decides to close the boot, he/she exerts a pressure upon the pressing element 30, in particular on the flat portion 36, compressing the spring 28. The pressing element 30 goes down and through the holes 40, 44 acts upon the pin 24 so as to push it. The pin 24 thus withdraws towards the smooth portion 6 sliding along the inclined planes of the holes 40, 44. Such holes 40, 44 acts as groove guides for receiving and guiding the pin 24. This groove has an extension (substantially rectilinear and inclined with respect to the longitudinal extension of the rack elements) such as to move the pin 24, and therefore the first rack element 5, from the first configuration to the second configuration.

30 **[0028]** Indeed, the pin 24 also pulls the rack 5 into translation, which moves towards the portion 6. In this second configuration the two racks 3, 5 have the respective toothed profile aligned, and this allows the blocking pin 50 to enter into, and engage, a recess 4.

35 **[0029]** Once the pin 50 has been inserted into the predetermined recess 4, the user releases the pressing element 30. The spring 28 extends and the device goes back into the first configuration, in which the cooperation of the toothings of the racks 3, 5 allows the pin 50 to be held firmly in the recess 4.

40 **[0030]** As an alternative to the pressing element 30 it is possible to connect a different pressing element 230 having holes 240, 244 of curvilinear elongated section to the rack element 3 (figures 7, 8).

45 **[0031]** The holes 240, 244 also act as groove guides for the pin 24. This time the groove has, in its extension, a portion substantially perpendicular to the longitudinal extension of the rack elements 3, 5 that joins to a portion that is substantially arched or inclined with respect to the longitudinal extension of the rack elements 3, 5. Thus at the start of the oscillation the element 30 does not induce a translation of the pin 24, i.e. a "dead" zone is created.

50 **[0032]** In accordance with another embodiment of the invention, a blocking device 101 is shown in figures 9-13,

in which parts in common with the previous ones keep the same reference numerals. Different parts shall be indicated with a suffix '1'.

[0033] A fixed rack 103 and a mobile rack 105 keep substantially the same configuration as the previous ones, in particular a longitudinal cavity in the fixed rack 103. Some particular embodiments, on the other hand, change. The pressing element 30 is not foreseen, and nor are attachment pins 24 and 26 foreseen.

[0034] The rack 103 comprises a smooth portion 106 in which two through holes 112 are formed symmetrically that make the sides of the rack 103 communicate with the cavity 7. The hole 112 has an elongated section, preferably elliptical, and when the rack 105 is mounted in the cavity 7 it aligns with the holes 112.

[0035] With regard to the rack 105, a through hole 122 is formed at a smooth portion 120 thereof adjacent to a toothed portion 121.

[0036] A U-shaped spring 128, equipped with a rectangular shank 129 and with a shank 131 bent to form a C-shaped recess, is inserted into the two holes 112 and into the hole 122, the latter also having an elongated section like that of the through holes 112. A plate 130 supports and holds the rack 105 in position inside the cavity 7.

[0037] When the boot is being closed, a user exerts a pressure with the pin 50 on the tooth corresponding to the recess of the rack 105 in which one wishes to insert it. The rack 105 is pushed by it and translates with respect to the rack 103 (towards the portion 106) thanks to the deformation of the shank 131 of the spring 128: the toothings of the two racks 103, 105 open out. Once the pin 50 has entered into the predetermined recess, the spring 128 takes the rack 105 back elastically into the original position, moving together the toothings of the racks 103, 105 so as to hold the pin 50 in the recess. The removal of the pin 50 is obtained by forcing the movement of the rack 105, pushing the pin 50 towards the spring 128.

[0038] Although the example embodiments have been given with reference to the specific field of boots and in particular ski boots, the invention can also be applied to other fields in which an effective binding between overlapping or side-by-side flaps of an opening is, more generally, required.

Claims

1. Blocking device (1; 101) comprising a first rack element (5; 105) and a second rack element (3; 103) with toothings arranged in cooperation to hold a blocking pin (50), **characterised in that** the first rack element (5; 105) is mounted so that it is mobile with respect to the second rack element (3; 103), so that the toothings of the rack elements (3, 5; 103, 105) can take up a first configuration in which they hold the blocking pin (50) and a second configuration in

which they release it.

2. Blocking device (1; 101) according to claim 1, wherein one of the rack elements (3, 5; 103, 105) is mounted so that it can translate with respect to the other.

3. Blocking device (1; 101) according to claim 2, wherein the second rack element (5; 105) comprises a longitudinal cavity (7) wherein the first rack element (3; 103) is translatably mounted, so that the rack elements have the respective toothings side-by-side.

4. Blocking device (1; 101) according to one of the previous claims, comprising elastic means (28; 128) to polarise the rack elements (3, 5; 103, 105) in the first configuration.

5. Blocking device (1; 101) according to claim 4, comprising a mechanism for taking the first rack element into the second configuration overcoming the polarisation of the elastic means.

6. Blocking device (1; 101) according to claim 5, wherein the mechanism comprises an actuation surface by pressing which the first rack element can be taken into the second configuration overcoming the polarisation of the elastic means.

7. Blocking device (1; 101) according to claim 6, wherein the actuation surface forms part of a button that is hinged onto the first rack element so as to be able to oscillate and is connected to the second rack element through a pin, firmly connected to one of the two, which can slide along the inclined edges of a seat formed in the other.

8. Blocking device (1; 101) according to claim 7, wherein the button is a curved slab that at a first end is hinged to an end part of the first rack element, the second end being provided with a guide groove to receive and guide a pin firmly connected to the first rack element, the groove having an extension such as to move the pin, and therefore the first rack element, from the first configuration to the second configuration.

9. Blocking device (1; 101) according to claim 8, wherein the guide groove has substantially rectilinear extension inclined with respect to the longitudinal extension of the rack elements.

10. Blocking device (1; 101) according to claim 8, wherein the guide groove has, in extension, a portion substantially perpendicular to the longitudinal extension of the rack elements that joins to a substantially arched or inclined portion with respect to the longitudinal extension of the rack elements, so that at the start of its oscillation the slab does not induce a trans-

lation of the pin.

11. Blocking device (1; 101) according to claims 7 to 10, wherein the elastic means comprise a spring that at one end is in opposition to the oscillation of the actuation surface and at the other is. 5
12. Blocking device (1; 101) according to claim 4, wherein the elastic means comprise a spring housed in a seat formed transversally in the second rack element and directly in abutment on the first rack element. 10
13. Blocking device (1; 101) according to claim 12, wherein the spring is U-shaped and has a branch that engages in a through hole of the first rack element. 15
14. Blocking device (1; 101) according to one of the previous claims, wherein the first rack element (5; 105) has a smaller number of teeth than the second rack element (3; 103). 20
15. Footwear comprising the closing mechanism according to claims 1 to 14. 25

30

35

40

45

50

55

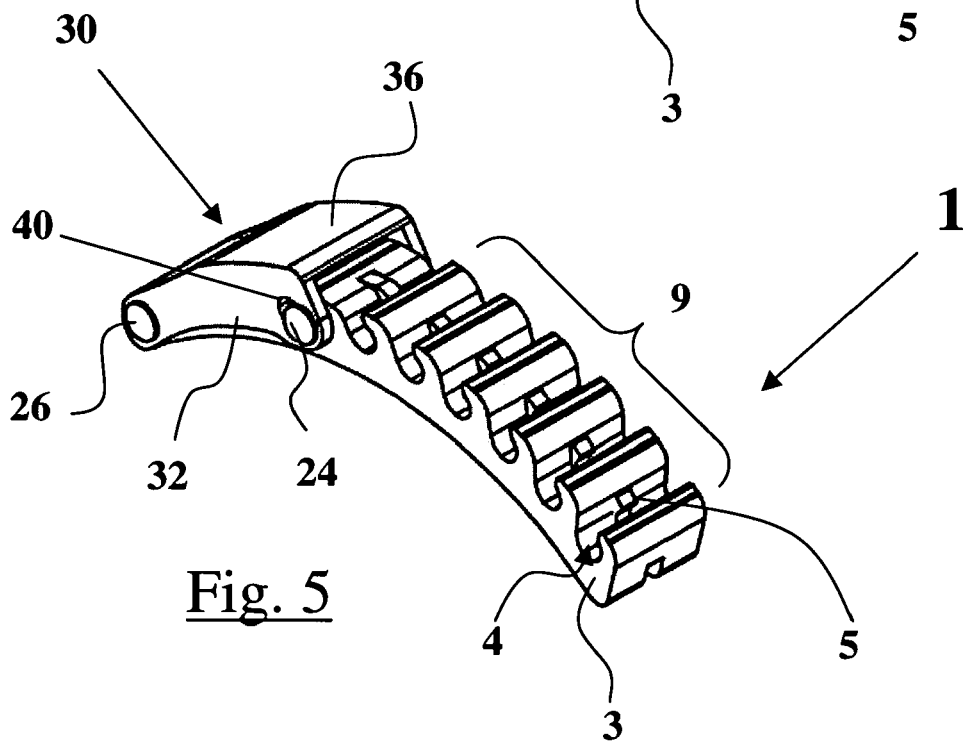
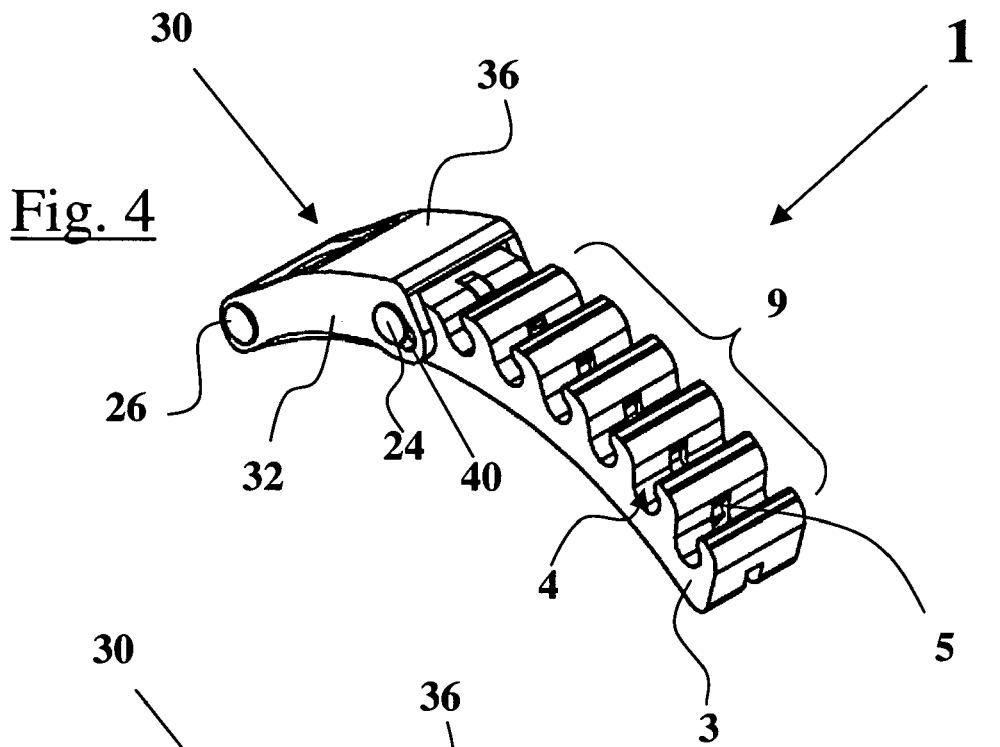

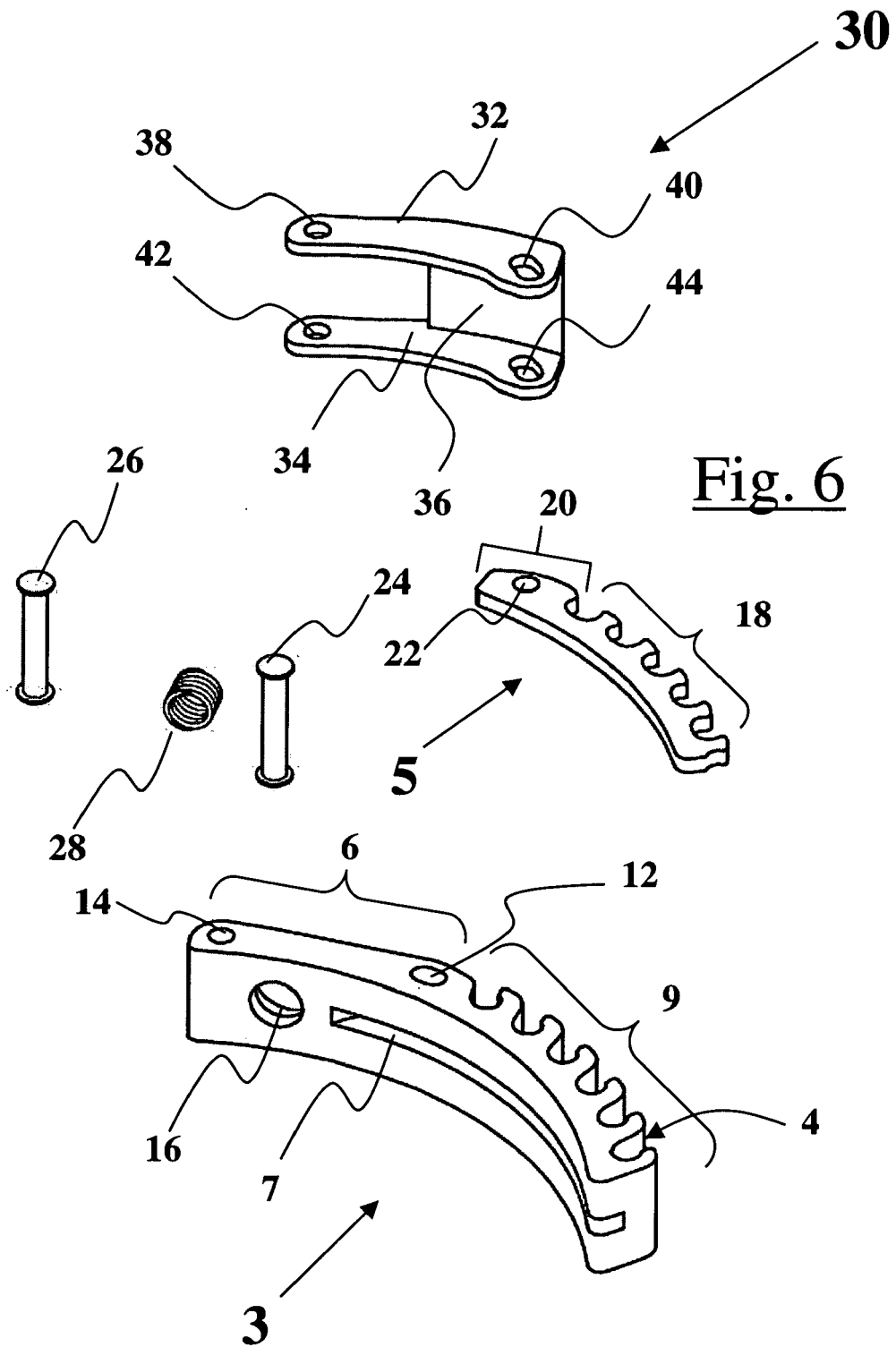

Fig. 7

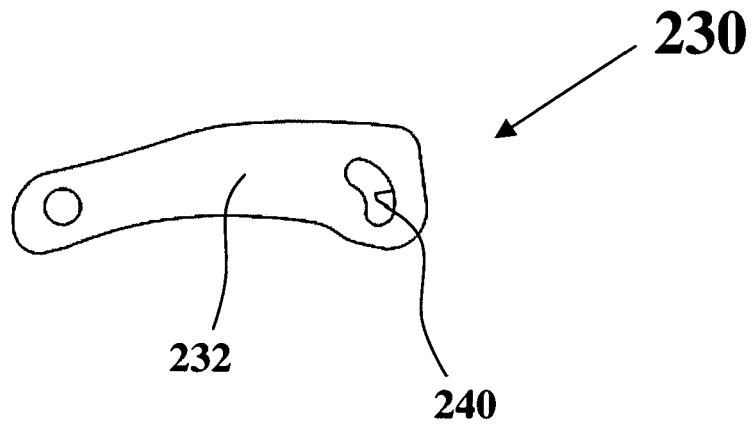
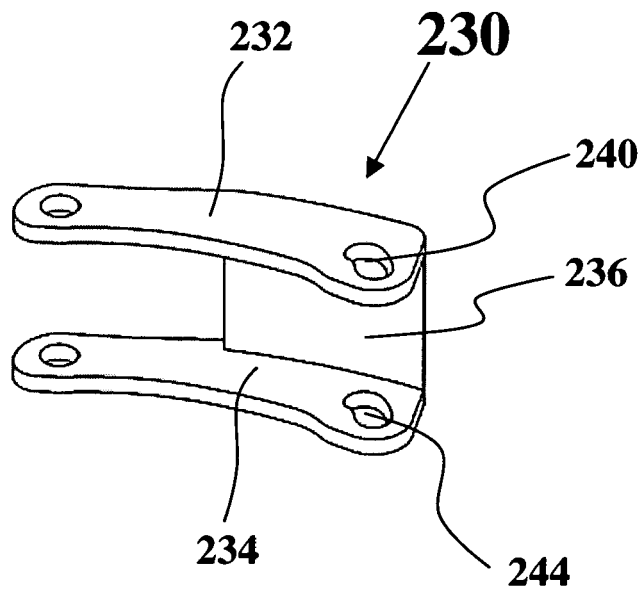
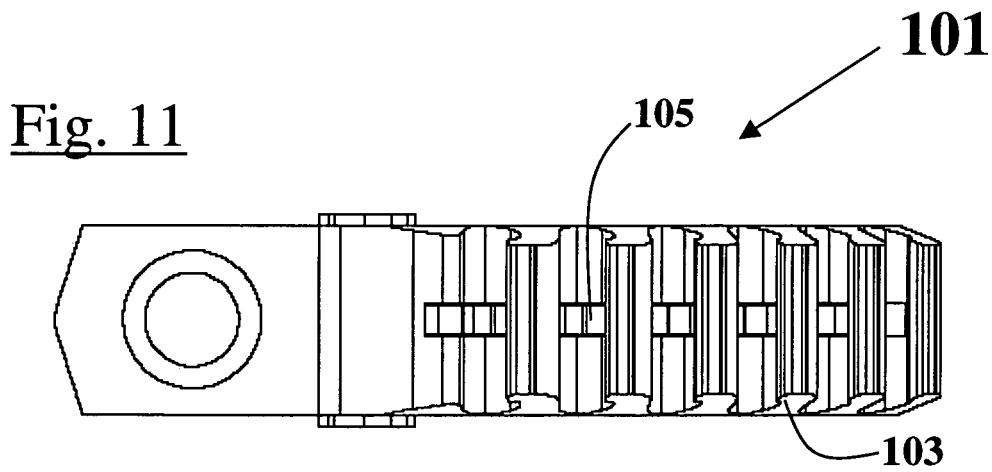
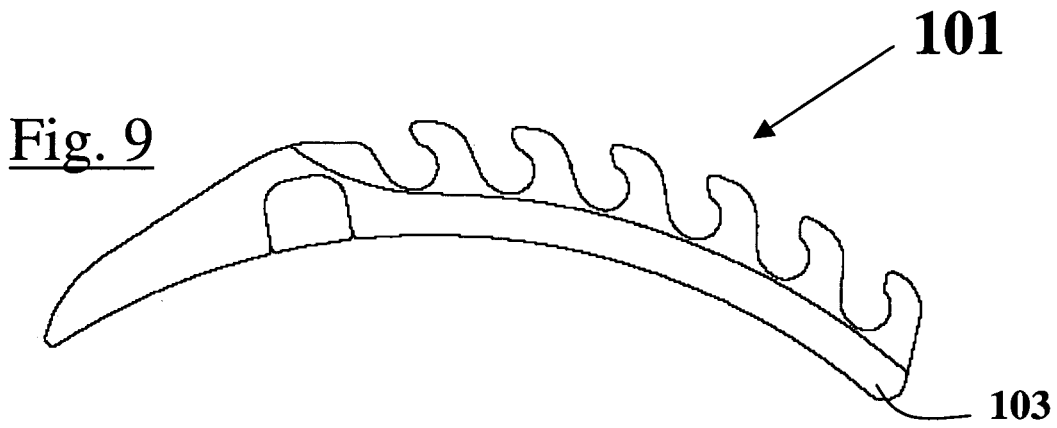
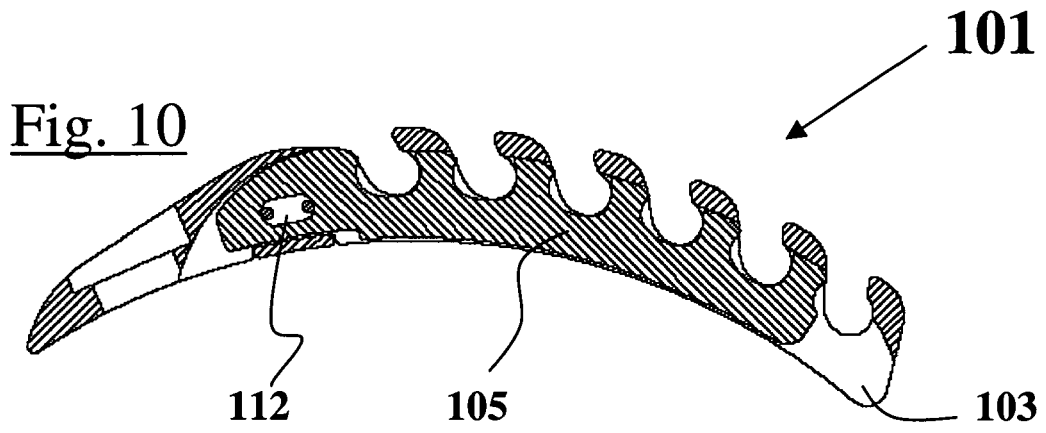
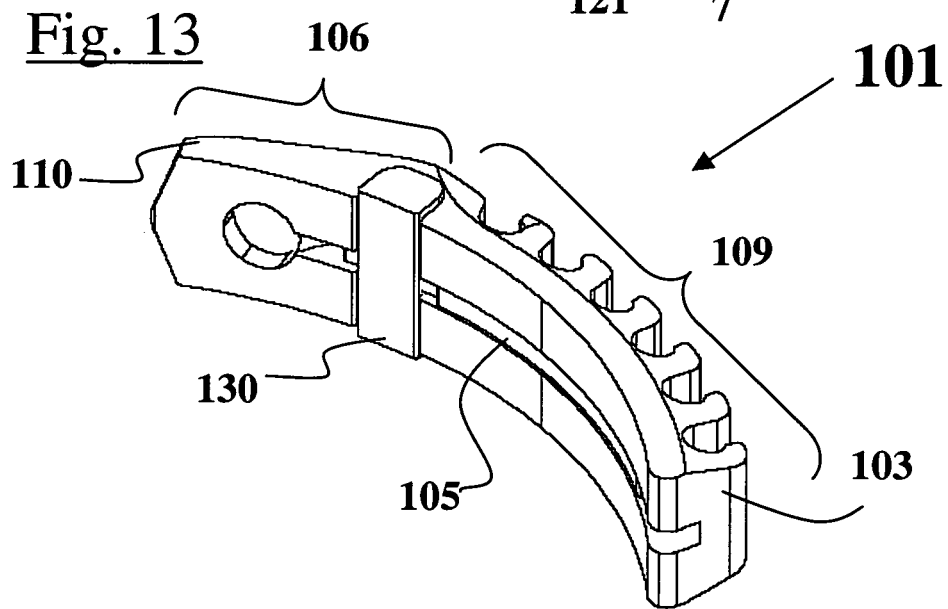
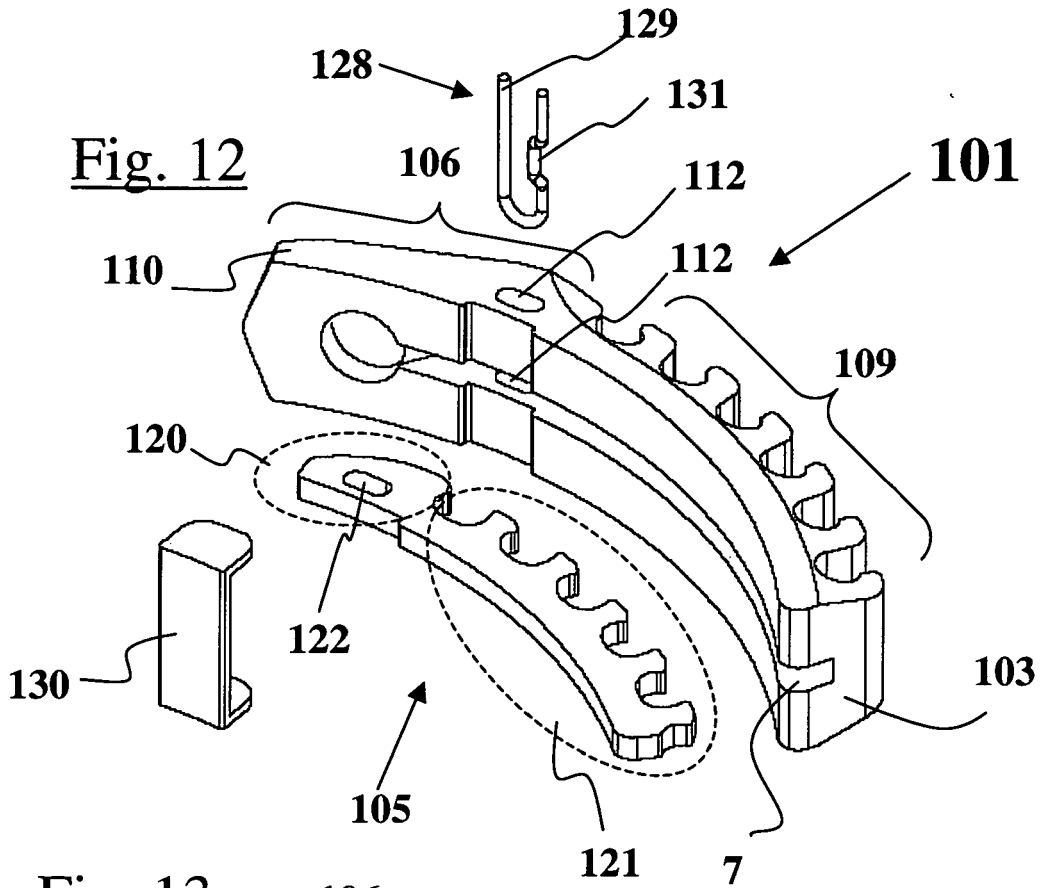

Fig. 8









DOCUMENTS CONSIDERED TO BE RELEVANT			
Category	Citation of document with indication, where appropriate, of relevant passages	Relevant to claim	CLASSIFICATION OF THE APPLICATION (IPC)
X	DE 19 61 034 U (STRASSER ERNA [DE]) 24 May 1967 (1967-05-24) * claims; figures *	1-15	INV. A43C11/14
X	DE 18 69 303 U (GRIESSER EMERAN [DE]) 21 March 1963 (1963-03-21) * claims; figures *	1-15	
A	DE 19 42 836 U (STOCKO METALLWARENFAB HENKELS [DE]) 21 July 1966 (1966-07-21) * claims; figures *	1-15	
A	EP 0 766 933 A (TECNICA SPA [IT]) 9 April 1997 (1997-04-09) * claims; figures *	1-15	
D,A	EP 0 663 155 A (LANGE INT SA [CH]) 19 July 1995 (1995-07-19) * claims; figures *	1-15	
A	US 3 521 330 A (STEINBERG ADALBERTO SUSSMAN) 21 July 1970 (1970-07-21) * claims; figures *	1-15	
			TECHNICAL FIELDS SEARCHED (IPC)
			A43C
The present search report has been drawn up for all claims			
Place of search		Date of completion of the search	Examiner
The Hague		28 November 2007	Claudel, Benoît
CATEGORY OF CITED DOCUMENTS			
X : particularly relevant if taken alone Y : particularly relevant if combined with another document of the same category A : technological background O : non-written disclosure P : intermediate document		T : theory or principle underlying the invention E : earlier patent document, but published on, or after the filing date D : document cited in the application L : document cited for other reasons & : member of the same patent family, corresponding document	

1
EPO FORM 1503 03.02 (P04C01)

ANNEX TO THE EUROPEAN SEARCH REPORT
ON EUROPEAN PATENT APPLICATION NO.

EP 07 42 5372

This annex lists the patent family members relating to the patent documents cited in the above-mentioned European search report. The members are as contained in the European Patent Office EDP file on
The European Patent Office is in no way liable for these particulars which are merely given for the purpose of information.

28-11-2007

Patent document cited in search report		Publication date	Patent family member(s)	Publication date
DE 1961034	U	24-05-1967	NONE	
DE 1869303	U	21-03-1963	NONE	
DE 1942836	U	21-07-1966	NONE	
EP 0766933	A	09-04-1997	IT TV950051 U1 JP 9108005 A US 5768804 A	04-04-1997 28-04-1997 23-06-1998
EP 0663155	A	19-07-1995	CH 689631 A5 DE 69500702 D1 DE 69500702 T2	30-07-1999 23-10-1997 12-03-1998
US 3521330	A	21-07-1970	NONE	

REFERENCES CITED IN THE DESCRIPTION

This list of references cited by the applicant is for the reader's convenience only. It does not form part of the European patent document. Even though great care has been taken in compiling the references, errors or omissions cannot be excluded and the EPO disclaims all liability in this regard.

Patent documents cited in the description

- EP 0663155 A [0002]