

631284

COMMONWEALTH OF AUSTRALIA
PATENTS ACT 1952
APPLICATION FOR A STANDARD PATENT

Minnesota Mining and Manufacturing Company, incorporated in Delaware, of 3M Center, Saint Paul, Minnesota 55144-1000, UNITED STATES OF AMERICA, hereby apply for the grant of a standard patent for an invention entitled:

Videotape Adaptor For Use With A Cartridge

which is described in the accompanying complete specification.

Details of basic application(s):-

<u>Basic Applic. No:</u>	<u>Country:</u>	<u>Application Date:</u>
481,986	US	20 February 1990

The address for service is:-

Spruson & Ferguson
Patent Attorneys
Level 33 St Martins Tower
31 Market Street
Sydney New South Wales Australia

DATED this EIGHTH day of JANUARY 1991

Minnesota Mining and Manufacturing Company

By:

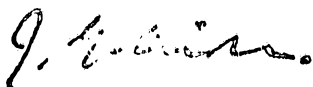

Registered Patent Attorney

TO: THE COMMISSIONER OF PATENTS
OUR REF: 151346
S&F CODE: 58180

PRINT OF RECEIPT

5019326 09/01/91

5845/2

DECLARATION IN SUPPORT OF A CONVENTION APPLICATION FOR A PATENT

In support of the Convention Application made for a patent for an invention entitled:

Title of Invention

Videotape Adaptor For Use With A Cartridge

I/~~We~~ Donald Miller Sell

Full name(s) and address(es) of Declarant(s)

care of Minnesota Mining and Manufacturing Company 3M Center, St. Paul, Minnesota 55144-1000 United States of America

do solemnly and sincerely declare as follows:-

Full name(s) of Applicant(s)

~~1. I am/We are the applicant(s) for the patent (or, in the case of an application by a body corporate)~~

1. I am/~~We are~~ authorised by

MINNESOTA MINING AND MANUFACTURING COMPANY the applicant(s) for the patent to make this declaration on its/~~their~~ behalf.

2. The basic application(s) as defined by Section 141 of the Act was/~~were~~ made

in United States of America

Basic Country(ies)

Priority Date(s)

on 20 February 1990

Basic Applicant(s)

by James E. Skavnak, John F. Kaman, Thomas A. Turgeon and Jerrold K. Weeks

Full name(s) and address(es) of Inventor(s)

~~3. I am/We are the actual inventor(s) of the invention referred to in the basic application(s) (or where a person other than the inventor is the applicant)~~

3. James E. Skavnak, John F. Kaman, Thomas A. Turgeon and Jerrold K. Weeks

of 4815 Xerxes Avenue South, Minneapolis, Minnesota 55410; 800 East Minnehaha, Minneapolis, Minnesota 55417; 1650 Camelot Lane, Fridley, Minnesota 55432 and 650-4th Street North, Hudson, Wisconsin 54016 all in United States of America (respectively)

Set out how Applicant(s) derive title from actual inventor(s) e.g. The Applicant(s) is/are the assignee(s) of the invention from the inventor(s)

~~I~~/are the actual inventor(s) of the invention and the facts upon which the applicant(s) is/~~are~~ entitled to make the application are as follows:

The said Company is the assignee of the actual inventors

4. The basic application(s) referred to in paragraph 2 of this Declaration was/~~were~~ the first application(s) made in a Convention country in respect of the invention(s) the subject of the application. Saint Paul,

Declared at Minnesota, this 12th day of November 19 90 U.S.A.

Donald Miller Sell

Donald Miller Sell, Chief Patent Counsel

(12) PATENT ABRIDGMENT (11) Document No. AU-B-69285/91
(19) AUSTRALIAN PATENT OFFICE (10) Acceptance No. 631284

- (54) Title
VIDEOTAPE ADAPTOR FOR USE WITH A CARTRIDGE
- International Patent Classification(s)
(51)⁵ G11B 023/087
- (21) Application No. : 69285/91 (22) Application Date : 09.01.91
- (30) Priority Data
- (31) Number (32) Date (33) Country
481986 20.02.90 US UNITED STATES OF AMERICA
- (43) Publication Date : 22.08.91
- (44) Publication Date of Accepted Application : 19.11.92
- (71) Applicant(s)
MINNESOTA MINING AND MANUFACTURING COMPANY
- (72) Inventor(s)
JAMES E. SKAVNAK; JOHN F. KAMAN; THOMAS A. TURGEON; JERROLD K. WEEKS
- (74) Attorney or Agent
SPRUSON & FERGUSON , GPO Box 3898, SYDNEY NSW 2001
- (57) Claim

1. An adaptor, for use with a tape cartridge of the type having a supply reel and having a gear flange on said supply reel for rotating said supply reel, comprising:

a housing adapted to receive said tape cartridge;

a take-up reel located in said housing, adapted for rotation within said housing;

said take-up reel, located in said housing having a gear flange for rotating said take-up reel;

gear train means located in said housing, for selectively coupling power to said supply reel and to said take-up reel;

lever means located in said housing coupled to said gear train means for supplying power to selectively wind said take up reel and to selectively rewind said supply reel.

631284

S & F Ref: 151346

FORM 10

COMMONWEALTH OF AUSTRALIA

PATENTS ACT 1952

COMPLETE SPECIFICATION

(ORIGINAL)

FOR OFFICE USE:

Class Int Class

Complete Specification Lodged:
Accepted:
Published:

Priority:

Related Art:

Name and Address
of Applicant: Minnesota Mining and Manufacturing Company
3M Center
Saint Paul Minnesota 55144-1000
UNITED STATES OF AMERICA

Address for Service: Spruson & Ferguson, Patent Attorneys
Level 33 St Martins Tower, 31 Market Street
Sydney, New South Wales, 2000, Australia

Complete Specification for the invention entitled:

Videotape Adaptor For Use With A Cartridge

The following statement is a full description of this invention, including the best method of performing it known to me/us

ABSTRACT

An adaptor for using a tape cartridge in a standard VHS videotape machine. The adaptor includes a thumb operated winder and a take up reel. The take up reel includes a clutch to minimize drag on the winder.

VIDEOTAPE ADAPTOR FOR USE WITH A CARTRIDGEFIELD OF THE INVENTION

5 The present invention relates to magnetic tape
cartridges and adaptors for use in videotape machines.
More particularly the invention relates to an adaptor
which adapts a specialized video-cartridge to the VHS
standard videocassette format.

10

DESCRIPTION OF THE PRIOR ART

Most home videotape machines use magnetic recording
media supplied in a videocassette format. The typical
videocassette contains both a supply reel and a take-up
15 reel. The inclusion of the empty take-up reel within
the videocassette housing makes this format inefficient
for tape storage.

The storage of videotape on a single supply reel
tape cartridge is an attractive alternative to the
20 video-cassette. The prior art teaches the use of a
single supply reel video cartridge for use with an
adaptor in British Patent Application GB 2,162,150A
published 29 January 1986.

In use, the prior art tape cartridge is assembled
25 into the adaptor to construct an assembly which forms a
conventionally sized videocassette. However, this prior
art system exhibits a number of problems which must be
addressed to produce a commercially useful video-
cartridge product.

30 For example, the tape in the cartridge must be
connected to a take-up reel located in the adaptor. In
this prior art system, a message cartridge is placed
into a modified cassette and a tape leader is drawn out
of the cartridge by hand and attached at the take-up
35 spool.

SUMMARY OF THE INVENTION

In contrast to the prior art, the adaptor of the present invention automatically connects the tape in the cartridge to the take-up reel in the adaptor.

5 The videotape adaptor includes mechanisms which cooperate with the inserted cartridge to automatically interconnect the tape on the supply reel in the cartridge with the take-up reel located in the adaptor. In operation, the insertion of the cartridge into the
10 adaptor mechanically interconnects a tape connector with a tether connector forming an interconnection.

 The adaptor of the present invention includes a novel winding mechanism in combination with a novel take-up reel.

15 The winding mechanism is provided to advance the interconnection from the supply reel, to the take-up reel. This operation must be completed prior to insertion of the adaptor into the videotape machine.

 At the conclusion of play within the videotape
20 machine, the winder mechanism is also used to rewind the interconnection to the supply reel of the adaptor.

 In addition, the adaptor contains a novel take-up reel with a clutch mechanism to reduce rewind drag. The clutch is disengaged during the manual advance and
25 rewind operations.

BRIEF DESCRIPTION OF THE DRAWING

In the drawing, in which like reference numerals indicate corresponding structures throughout the views:

30 FIG. 1 is a top view of the adaptor showing the gear train in phantom view;

 FIG. 2 is a top view of a cartridge suitable for use with the adaptor;

 FIG. 3 is a top view of the cartridge inserted into
35 the adaptor with the adaptor door in the closed position;

FIG. 4 is an exploded view of the take-up reel assembly;

FIG. 5 is an exploded view of the winder gear train assembly.

5

DETAILED DESCRIPTION OF THE PREFERRED EMBODIMENT

In the following detailed description of the preferred embodiment, reference is made to an illustrative embodiment of the invention. It is to be understood that other embodiments may be utilized without departing from the scope of the present invention.

U.S. Patent Application 07/343,851, filed 04/26/89; U.S. Patent Application 07/353,826, filed 05/18/89; U.S. Patent Application 07/398,068, filed 08/24/89; U.S. Patent Application 07/398,069, filed 08/24/89; U.S. Patent Application 07/381,159, filed 07/17/89; and U.S. Patent Application 07/482,071, filed February 20, 1990 relate to the tape cartridge and adaptor technology described herein. Each of these applications is incorporated by reference.

In general terms, and with reference to Fig. 1, the user inserts the video cartridge 10, into the adaptor 12. The cartridge 10 is shown in isolation in Fig. 2. The cartridge 10 is inserted into the adaptor 12 by opening the door 30 of the adaptor 12 and placing the cartridge 10 into a door pocket. Once the cartridge is seated in the door pocket, the door 30 is rotated from a first "open" position to a second "closed" position. Fig. 1 and Fig. 3 depict the door in the closed position. The door 30 pivots about an axis formed by hinge axle 31 and 32, as shown in Fig. 3.

The door closure operation performs a number of separate actions. Door closure seats the cartridge in the adaptor which releases a ratchet brake mechanism, shown generally in Fig. 2 as 33. Release of the ratchet

brake mechanism permits the supply reel to rotate within the cartridge housing.

Door closure also makes the connection between a tape connector 7, and a tether connector 8. This union is called the interconnection and it is depicted as 16 in Fig. 3. The tape connector 7 is attached to a leader which is attached to the tape 14 stored on the supply reel 19. The tether connector 8 is connected to a tether 9 which, in turn, is attached to the take up hub 44 of the take-up reel 51. The completion of the tape-tether interconnection operates an interlock which releases the tape-tether interconnector at the cartridge at the position labeled 5. At this point the tape is free to move in the "play" direction.

The tape-tether interconnection 16 must be transferred to the take up reel 51 before the adaptor 12 is inserted into the video tape machine to prevent damage to the tape heads of the videotape machine.

A manually operated winding mechanism disclosed herein, is provided to permit the operator to advance the tape-tether interconnection 16 in the play direction, onto the take up reel. This process moves the tape-tether interconnection from a "home position" in a corner 5 of the cartridge to a "play position" where the interconnection is wound onto the take-up reel. This event prepares the adaptor for insertion into the videotape machine.

At the conclusion of play, the adaptor is removed from the videocassette machine at the end of the rewind cycle. The rewind cycle leaves the interconnection on the take-up side of the adaptor in the "play position". The user then operates the manually operated winder to return the tape-tether interconnection 16 to the "home position" 5. Once the interconnection is in the home position, the user may rotate the door into the open position and remove the cartridge from the adaptor.

The winding mechanism is displayed in phantom view in Fig. 1. Power is applied to the winder by actuation of the thumb lever 50 which may be moved in an arcuate path, pivoting about the axis of the take up reel 51.

5 As previously described the winder can move the tape in either the "play" direction or the "rewind" direction. Movement in the "play" direction is accomplished by applying force to the lower gear tooth flange 49 of the take up reel 51. Movement in the
10 "rewind" direction is accomplished by applying force to the gear tooth flange 20 of the supply reel 19. Both of these gear tooth flanges are located on the bottom of their respective reels.

The gear train which selectively transfers power
15 from the thumb lever to the appropriate gear flange includes a number of mechanical elements. With reference to the exploded perspective view of Fig. 5, and the plan view of Fig. 1, a planetary gear set 48 is driven by the thumb lever 50. Power is transferred out
20 of the planetary gear set through the sun gear 56. The sun gear is concentric with, and attached to a spur gear 59 through a ratchet assembly 47. Power is taken from the spur gear 59 through an idler gear 61 which delivers power to a transfer gear set 62 which drives a clapper
25 gear 68. The clapper gear is a switch gear which may selectively engage either the take up reel gear flange 49 (Fig. 3) or the supply reel gear flange 20 (Fig. 2).

In greater detail and with reference to Fig. 1 the thumb lever 50 is attached to a planet gear carrier 53.
30 A single planet gear 54 is mounted for rotation on the carrier 53 and engages a fixed, toothed sector gear segment 55 and a sun gear 56. The planet gear carrier 53 is pivotally mounted concentric with the sun gear 56 and is free to rotate in a arcuate path from a first
35 "retracted" position 66 to a second "extended" position 57. A constant force spring 57 (Fig. 5) is provided to return the lever from the extended position to the

retracted position. Rotary motion imparted to the sun gear 56 by the thumb lever is transferred through a ring of ratchet teeth 58 to a spur gear 59. The spur gear 59 engages a pawl 60 (Fig. 1) to prevent reverse rotation of the spur 59 as the lever 50 is retracted by the constant force spring 57. This pawl 60 cooperates with the ratchet assembly 47 to convert the lever motion into a rotary motion and to permit multiple strokes of the lever 50 to be accumulated to move the tape 14.

The gear ratios are selected to provide approximately one reel rotation per lever stroke and approximately 4 lever strokes are required to advance the tape tether interconnection 16 from the home position 5 to the play position. Preferably, the selected reel will rotate one revolution for each stroke of the winder.

The idler gear 61 couples motion from the spur gear 59 to the transfer gear assembly 62 (Fig. 5). The transfer gear assembly serves to transfer power from the upper portion of the adaptor to the lower portion of the adaptor. The output transfer gear 65 engages and drives the clapper gear 68. The clapper gear is mounted to a pivoting arm 81 which may be moved selectively, from engagement with the take up reel lower flange 49, to engagement with the supply reel lower flange gear 20. In operation the arm 81 rotates as a reaction to the rotational input to the input transfer gear 80. The clapper gear is dragged into position by frictional engagement with the transfer gear assembly made up of gears 80 and 65. Thus, the direction of rotation of the transfer gears selects which of the two reels is engaged by the clapper gear 68.

In Fig. 1 the idler gear 61 is shown in direct engagement with the spur gear 59. Reverse rotation of the transfer gear assembly is required for rewind action. For reverse or rewind rotation the lower gear flange 20 of the supply reel 19, is driven by the

winding mechanism. To change the direction of rotation the idler gear 61 is mounted on a rocker 71 which pivots about the axis of transfer gear assembly 62. Manual movement of the rocker 71 moves the idler gear 61 into
5 engagement with a small reversing gear 72 which changes the direction of rotation of the idler gear 61.

The elements of the transfer gear assembly 62 are shown in Fig. 5. Power is supplied to the transfer gear assembly from the idler gear 61. This gear engages the
10 input transfer gear 80. This input transfer gear 80 is attached the output transfer gear 65 through a mating structure shown in Fig. 5 as a square tooth spline 46.

The clapper gear 68 is mounted on an arm 81 which is adapted for pivotal motion around the axis of the
15 transfer gear assembly. Rotation about this pivot will cause the clapper gear to engage either the supply reel gear flange 20 or the take up reel gear flange 49. The arm rotates into engagement with the selected gear flange through the rotation of the arm 81.

20 In operation, the user may advance or rewind tape through the thumb operated clapper gear. However once the adaptor has been inserted into the videotape machine the tape transport will insert a pin into the aperture 45 formed in the adaptor as seen in Fig. 3. The pin,
25 which is not shown, contacts the conical interior surface of the clapper gear 68 and disengages it from either of the reel gear flanges.

It is important to reduce gear train drag wherever possible to improve the acceptability of the adaptor. A
30 significant reduction in drag is achieved in the present design by de-coupling the take up reel drive spline 38 from the take up reel hub 44 under certain operating conditions. It is preferred to have the drive spline de-coupled while the adaptor winder is being used. This
35 result is achieved through the use of a specialized dog clutch.

In general terms, and with reference to Fig. 4, the take up reel 51 is made up of an upper 43 and lower gear flange 49 which are bonded to the hub take up hub 44. These three elements form a unitary spool for receiving and storing tape. The take up reel 51 is driven by the videotape machine through a drive hub assembly 42. In operation, the video tape machine introduces a drive spindle into the spline hub 38 to rotate the take-up reel.

10 The splined hub 38 is connected to the dog hub 39 and forms a unitary structure with the dog hub 39. The dog ring 36 is forced away from the dog hub 39 by a spring washer 37. Flange surfaces the on the ends of the dogs 23-25 of the dog ring 36 cooperate with the
15 retainer ring 35 to retain the dog ring 36 in alignment with the holes 26-28 of the dog hub 39. In operation, rotary motion supplied to the spline hub 38 is imparted to the take-up hub 44 if the dogs 23-24 inserted into and engage the holes 26-28 spaced around the outer edge
20 of the dog hub 39. Typically, this condition will occur when the adaptor is in the videotape machine and the videotape machine drive spindle has entered the splined hub 38 and compressed the spring washer 37. Typically when the adaptor is out of the videotape machine the
25 spring washer 37 urges the dogs out of engagement with the drive holes 74-76 of the take-up hub 44 and thus disengages the clutch, permitting free rotation of the take-up reel by the winder mechanisms.

This illustrative embodiment of the invention
30 provides a convenient and effective method of preparing the adaptor for insertion into a videocassette machine.

The claims defining the invention are as follows:

1. An adaptor, for use with a tape cartridge of the type having a supply reel and having a gear flange on said supply reel for rotating said supply reel, comprising:
 - a housing adapted to receive said tape cartridge;
 - a take-up reel located in said housing, adapted for rotation within said housing;
 - said take-up reel, located in said housing having a gear flange for rotating said take-up reel;
 - gear train means located in said housing, for selectively coupling power to said supply reel and to said take-up reel;
 - lever means located in said housing coupled to said gear train means for supplying power to selectively wind said take up reel and to selectively rewind said supply reel.
2. The adaptor of claim 1 wherein said gear train means comprises:
 - ratchet means located in said housing coupled to said lever means for converting lever motion into rotary motion;
 - gear means located in said housing coupled to said ratchet means for transferring said rotary motion to a clapper gear;
 - said gear means including selection means for selectively directing power to either said take-up reel or said supply reel;
 - said clapper gear mounted for pivotal motion, coupled to said gear means for selectively transferring power to rewind said supply reel and for selectively transferring power to wind said take-up reel.

3. The adaptor of claim 1 wherein said gear train means comprises:

planetary gearset means coupled to said lever means for converting reciprocating motion of said lever
5 to a rotary motion;

transfer gear means coupled to said planetary gearset means for transferring said rotary motion to said supply reel and to said take-up reel, to selectively wind said take up reel and to selectively
10 rewind said supply reel.

4. An adaptor, substantially as described herein with reference to the accompanying drawings.

DATED this SEVENTH day of JANUARY 1991
Minnesota Mining and Manufacturing Company

Patent Attorneys for the Applicant
SPRUSON & FERGUSON

69285

FIG. 1

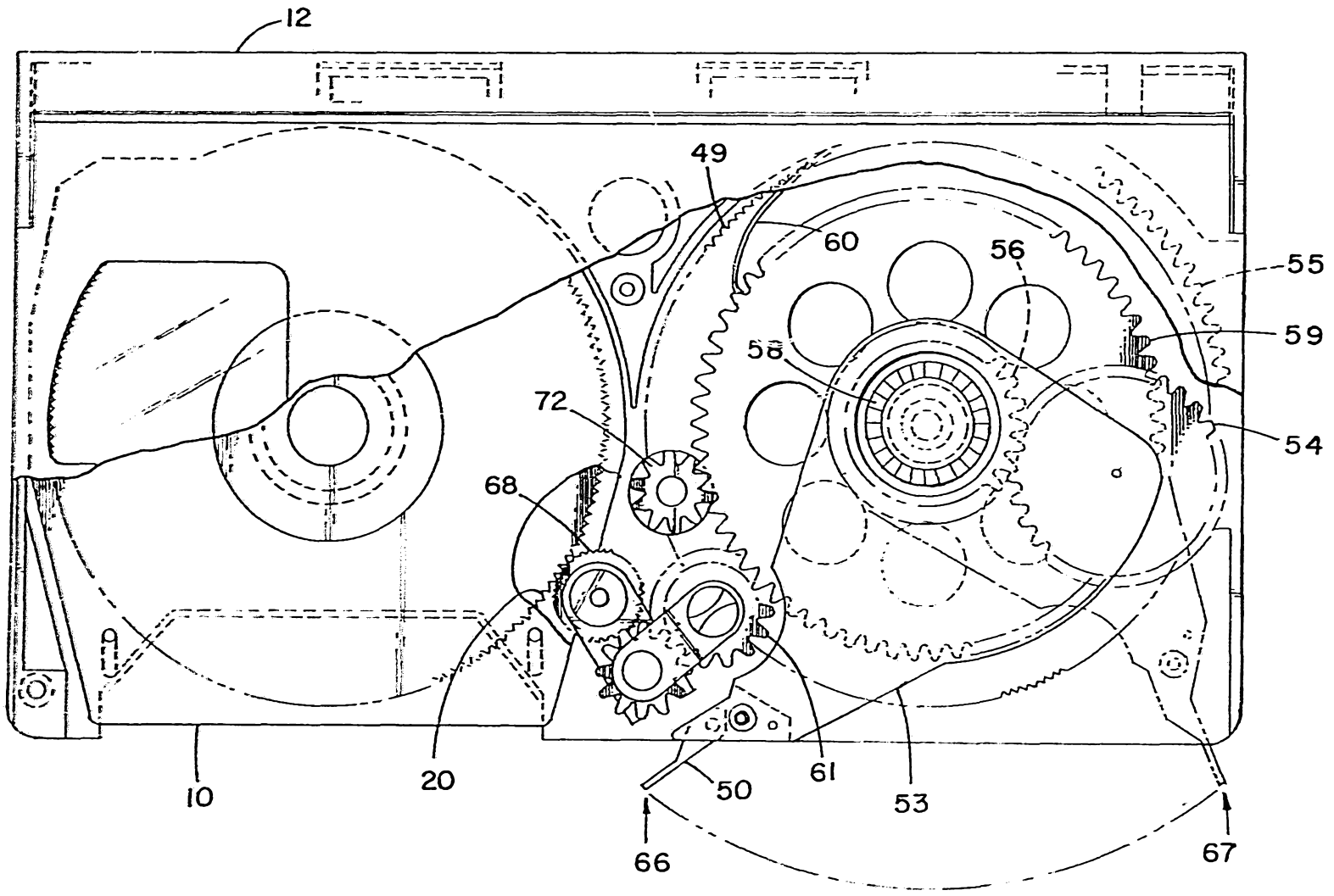

69285/91

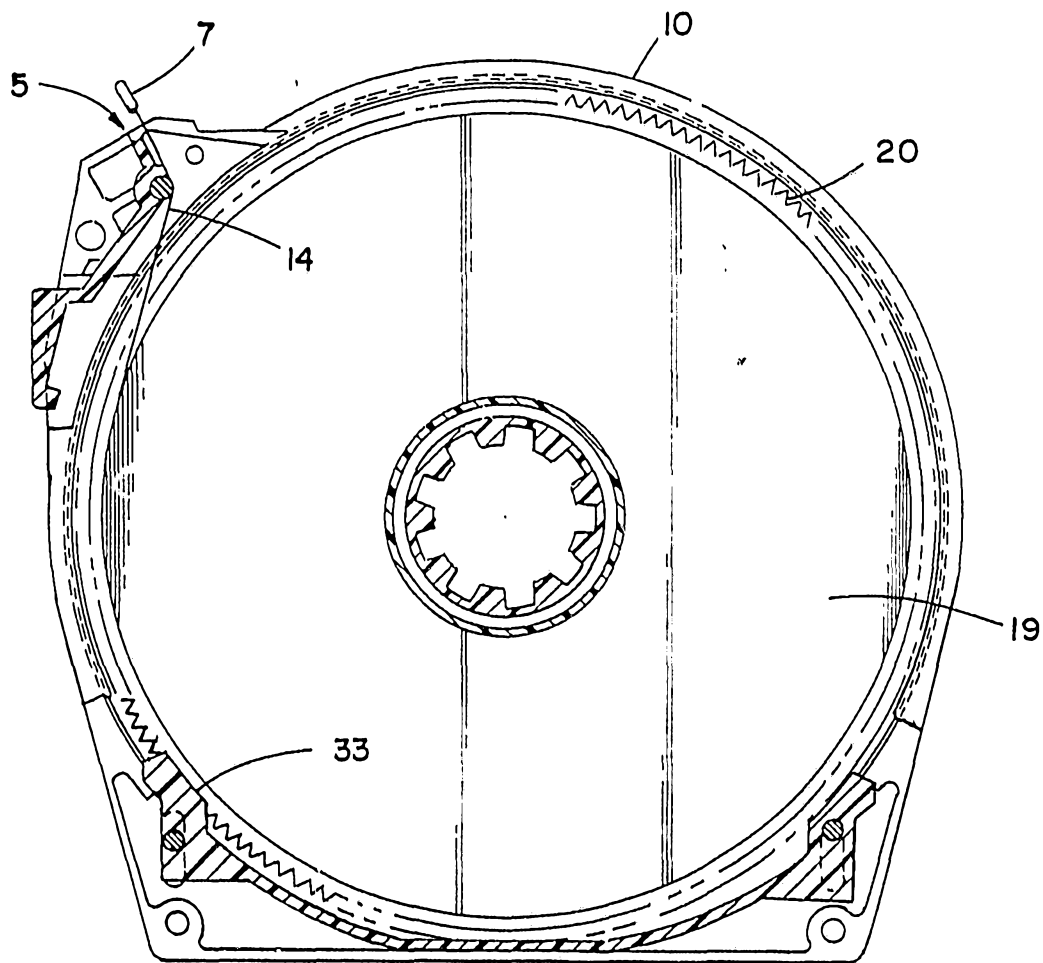

FIG. 2

FIG. 4

