

No. 864,584.

PATENTED AUG. 27, 1907.

H. G. WOOD.  
INTERNAL COMBUSTION ENGINE.  
APPLICATION FILED JULY 20, 1904.

4 SHEETS—SHEET 1

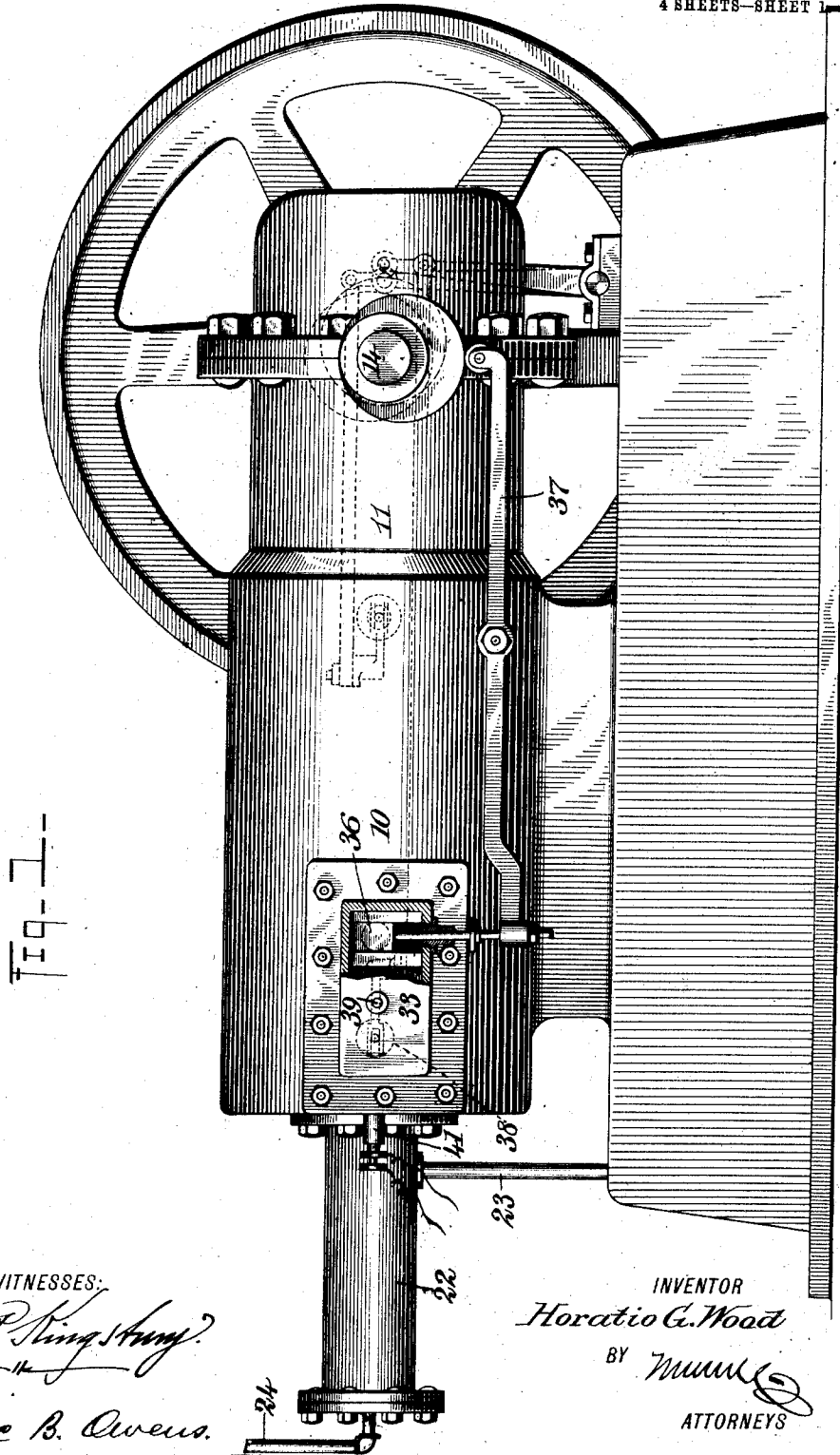

WITNESSES:  
*Geo. P. King*  
*Isaac B. Owens*

INVENTOR  
*Horatio G. Wood*  
BY *Wm. M. Wood*  
ATTORNEYS

No. 864,584.

PATENTED AUG. 27, 1907.

H. G. WOOD.  
INTERNAL COMBUSTION ENGINE.  
APPLICATION FILED JULY 20, 1904.

4 SHEETS—SHEET 2.

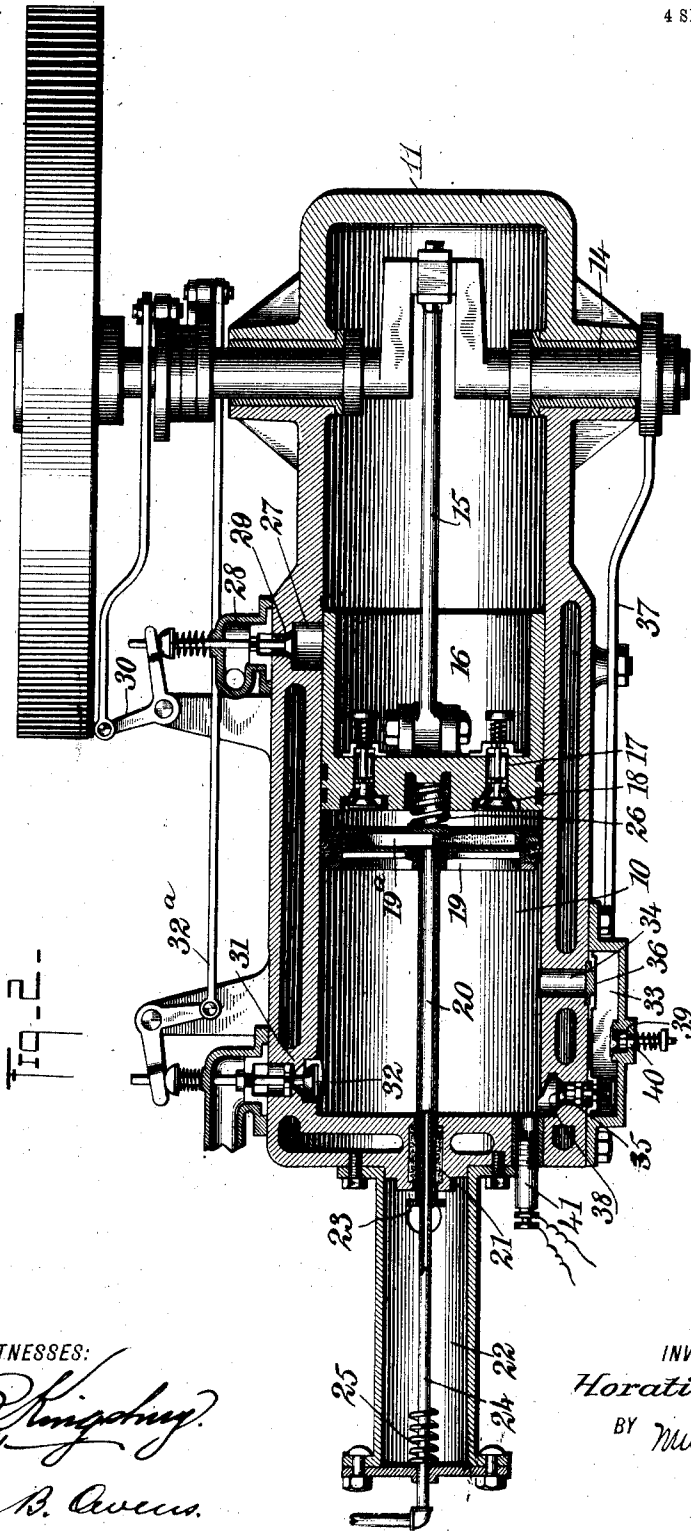

WITNESSES:

*Geo. Kingdum*

*Franc B. Owens*

INVENTOR

*Horatio G. Wood*

BY

*Mumford*

ATTORNEYS

No. 864,584.

PATENTED AUG. 27, 1907.

H. G. WOOD.  
INTERNAL COMBUSTION ENGINE.  
APPLICATION FILED JULY 20, 1904.

4 SHEETS—SHEET 3.

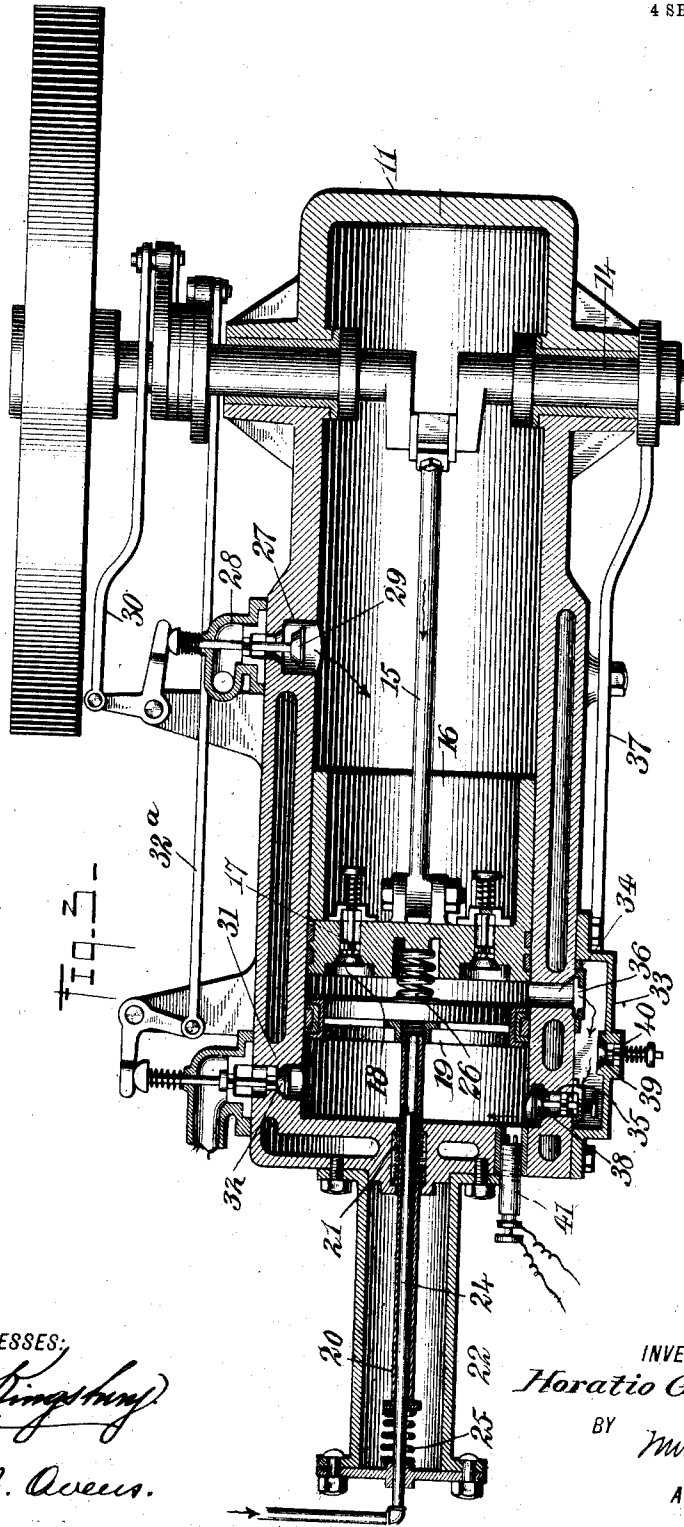

WITNESSES:  
*Geo. P. Kingsbury*  
*Isaac B. Owens.*

INVENTOR  
*Horatio G. Wood*  
BY *Wm. M. Wood*  
ATTORNEYS

No. 864,584.

PATENTED AUG. 27, 1907.

H. G. WOOD.  
INTERNAL COMBUSTION ENGINE  
APPLICATION FILED JULY 20, 1904.

4 SHEETS—SHEET 4.

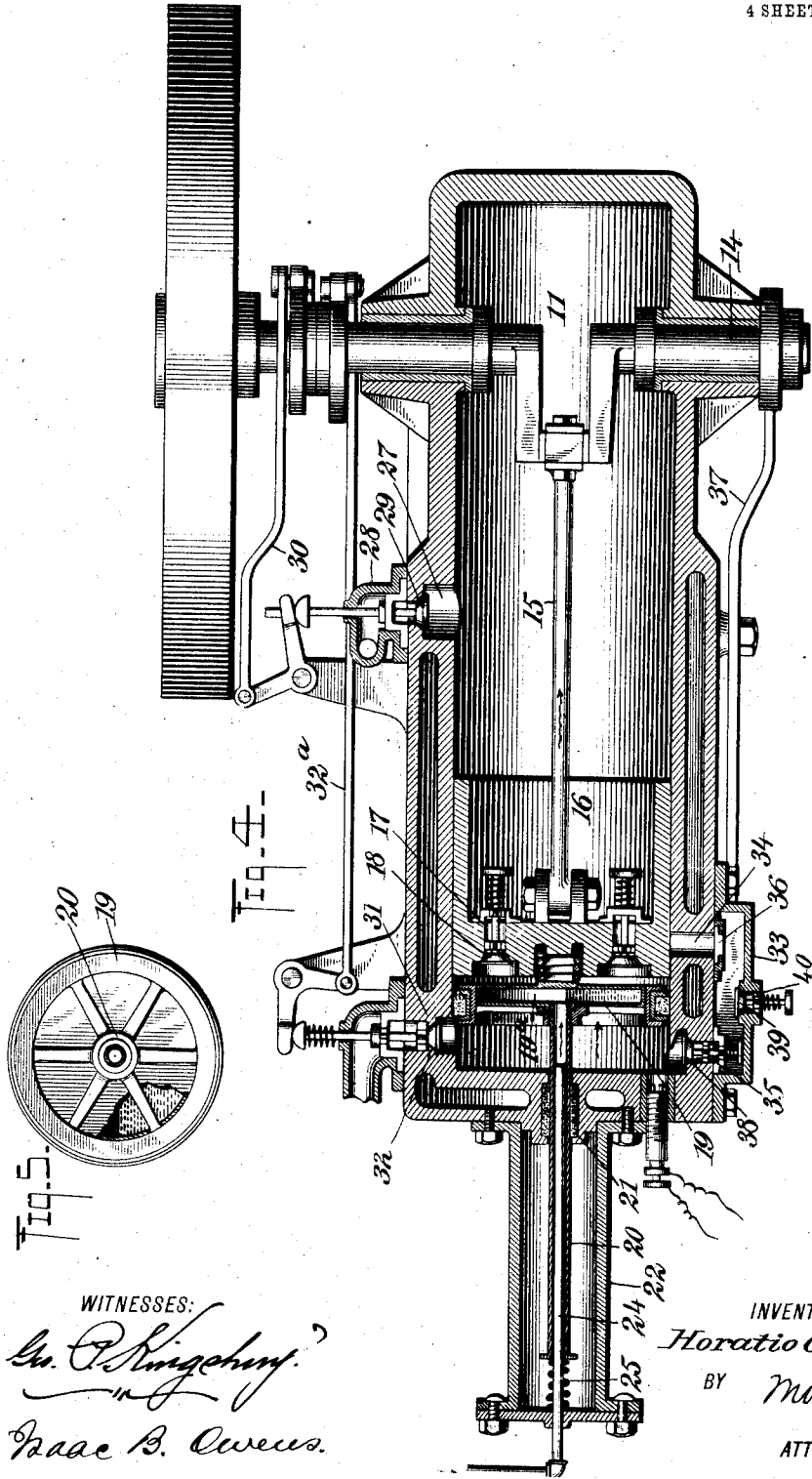

WITNESSES:  
*Geo. A. Kinghorn*  
*Francis B. Owens*

INVENTOR  
*Horatio G. Wood*  
 BY *Mumuk*  
 ATTORNEYS

# UNITED STATES PATENT OFFICE.

HORATIO G. WOOD, OF NEWPORT, RHODE ISLAND.

## INTERNAL-COMBUSTION ENGINE.

No. 884,584.

Specification of Letters Patent.

Patented Aug. 27, 1907.

Application filed July 20, 1904. Serial No. 217,350.

*To all whom it may concern:*

Be it known that I, HORATIO G. WOOD, a citizen of the United States, and a resident of Newport, in the county of Newport and State of Rhode Island, have  
5 invented a new and Improved Internal-Combustion Engine, of which the following is a full, clear, and exact description.

The prime object of this invention is to improve a means for scavenging the cylinder of an internal combustion engine. I attain this end by providing a peculiar scavenging piston which operates in such a manner as to clear out the product of combustion from the cylinder, and to avoid the necessity of using the power piston at certain times as a pump for forcing out  
10 the burned gases. The apparatus also involves a certain novel means for introducing the fuel charge into the cylinder, and further means for cooling the scavenger piston by the circulation of a cooling fluid therein, no claims for the last mentioned means being incorporated in this application.

Certain features of the subject-matter of the present application were disclosed in my co-pending application Serial Number 151,299, filed April 6, 1903, of which co-pending application the present application  
25 is a continuation.

Reference is had to the accompanying drawings which show as an example one manner of practically embodying my invention, in which drawings like letters of reference indicate like parts throughout the several views, and in which

Figure 1 is a side elevation of the engine with part of the walls of the fuel transfer passage broken away; Fig. 2 is a horizontal section of the engine showing the power and scavenging pistons at the end of their out stroke, and illustrating the exhaust valve in open position; Fig. 3 is a similar section, the power piston, however, being shown with about one-half of its compression stroke completed, and with the scavenger piston at the end of its in-stroke, at which period in the  
40 operation of the engine the fuel mixture is automatically transferred from the crank case or other compressor into the compression chamber of the engine; Fig. 4 is a similar section showing the power and scavenger pistons in the position which they assume upon the inception of the power stroke; and Fig. 5 is an elevational view of the scavenger piston with parts broken away to show the water circulating cavity thereof.

10 indicates the cylinder of the engine which may be water jacketed, if desired, and 11 indicates a closed crank case in which is mounted the crank shaft 14, connected by a rod 15 with the power piston 16. Said piston is provided with one or more ports 17 passing through it, and these ports are commanded by spring seated valves 18 opening at the inner side of the piston  
55 to allow the charge of combustible mixture to pass from

the crank case through the piston, as will be hereinafter fully set forth.

19 indicates the scavenger piston which is arranged within the cylinder 10, and which with the power piston is provided with suitable packing to form an hermetic connection between the pistons and the cylinder walls. The scavenger piston is also formed with a chamber 19<sup>a</sup> adapted to receive the cooling fluid. Communicating with this chamber is a centrally located tube 20 attached to and moving with the piston. Said tube slides freely through suitable packing 21 arranged in the head of the cylinder 10. Fastened to the head of the cylinder is a case 22 from which passes a water outlet pipe 23. Extending centrally into and through the case 22 is a pipe 24 connected with a suitable source of water or other cooling fluid. The pipe 24 telescopes within the tube 20, sufficient space being allowed between the two to permit the over-flow of cooling water from the chamber 19<sup>a</sup> to pass continually out into the case 22, and from the same by way of the outlet 23.

25 indicates a buffer spring arranged in the case 22 at the outer end thereof adapted to be struck by the flanged outer end of the pipe 20 to limit the inward or leftward movement of the scavenger piston. (See Fig. 3.)

26 indicates a buffer spring carried by the power piston 16 and adapted to be struck by the scavenger piston to limit the outward or rightward movement thereof. The crank case 11 is provided with a fuel mixture inlet port 27, communicating with a connection 28 carrying the fuel mixture, and commanded by an inwardly opening valve 29. This valve is mechanically operated by suitable gear 30 periodically actuated from the crank shaft. An exhaust port 31 leads from the inner part of the cylinder 10, and is controlled by a valve 32 periodically actuated by a suitable gear 32<sup>a</sup> driven from the crank shaft. A transfer chamber or passage 33 communicates with two ports 34 and 35, said ports leading into the cylinder 10. The port 34 is commanded by a slide valve 36 periodically opened through the action of a suitable gear 37, actuated from the crank shaft 14, and the port 35 is controlled by an inwardly opening spring seated valve 38.

39 indicates a valve which is arranged to command an opening 40 from the passage 33 to the atmosphere, the valve 39 being spring seated and opening inwardly to avoid a partial vacuum when the engine is running empty. The cylinder 10 is provided with a spark plug 41 or any other desired means for igniting the fuel charge.

The operation of the engine may be traced as follows: Upon the in-stroke of the piston 16 the valve 29 is opened and a charge of the fuel mixture is drawn into the crank case through the port 27. Upon the out or power stroke of the piston 16 this charge is compressed,

110

and when the parts reach the position shown in Fig. 2 the exhaust valve 32 is opened whereupon the pressure in the cylinder 10 falls to that of the atmosphere. Simultaneously, the valves 18 are automatically opened by the superior pressure in the crank case, and the fuel charge rushes through the piston 16 and forces inward the scavenger piston 19 giving the same a considerable lead over the piston 16, this inward movement of the scavenger piston being assisted by the previously compressed spring 23. The piston 16 then advances further to compress the fuel which is passed through the same, and at this period the valves 18 are automatically returned to their seats. The now separated scavenger and power pistons move forward in the relative positions shown in Fig. 3, the fuel charge being retained, however, between the two pistons, and the scavenger piston forcing out ahead of it the products of combustion remaining in the cylinder, this product passing out through the exhaust valve 32 which is kept open during this period of the compression stroke. When, however, the parts actually reach the position shown in Fig. 3 the slide valve 36 is opened and the compressed charge between the scavenger and power pistons is allowed to pass into the transfer chamber 33, and moving open the valve 38 rushes into the space between the scavenger piston and the cylinder head. The power piston continues to advance without, however, imparting any further movement to the scavenger piston since the pressure on both sides of this piston will then be equal. This movement of the power piston continues until the two pistons again reach close proximity to each other. The exhaust valve will have been closed immediately previous to the opening of the valve 36, and at the end of the compression stroke the charge then lying between the scavenger piston and cylinder head is ignited, whereupon both pistons are driven out in unison, this movement constituting the power stroke. When the parts reach the outer position the exhaust valve 32 is again opened and a fresh charge rushes through the power piston bringing about a repetition of the above described operation. It will be seen, therefore, that on the compression stroke of the power piston the scavenger piston moves ahead throwing out the burned gases, and then as the power piston nears the limit of its inward compression, stroke, the valve 36 is opened and the transfer passage 33 is allowed to conduct the charge around the scavenger piston to lie in the space between said piston and the cylinder head, and then upon the ignition of the charge both pistons move outward; consequently an effective means is provided for cleaning out the burned gases from the cylinder without consuming a piston movement for these charges, and in this way I am enabled to secure a power impulse for every revolution of the crank case with as effective a scavenging of the cylinder as in the typical four cycle engine. The water or other cooling fluid is constantly fed through the pipe 24 in the usual manner, and from this pipe into the pipe 20 and chamber 19<sup>a</sup> of the piston 19, thus filling the chamber with the cooling water, which water is caused to circulate therein by the movement of the piston and also by the injection of the stream from the pipe 24, particularly when the parts are in the position shown in Fig. 3. The surplus water runs out from the outer end of the pipe 20 through the space between said pipe and the pipe 24. This enables the tempera-

ture of the scavenger piston to be kept down to the desired degree notwithstanding that the piston is directly exposed to the heat of the burning charges.

Various changes in the form, proportions and minor details of my invention may be resorted to at will without departing from the spirit and scope thereof; hence I consider myself entitled to all such variations as may lie within the terms of my claims.

Having thus described my invention, I claim as new, and desire to secure by Letters Patent:—

1. An internal combustion engine having a working cylinder and piston, the latter having a port therein, an automatic valve commanding the port and opening into the working cylinder, a closed chamber at the outer side of the piston, a valve opening into the same, and controlling the fuel supply, a chambered scavenger piston free in the working cylinder, a hollow rod attached to and communicating with the scavenger piston and movable through the working cylinder head, means for introducing a cooling fluid into said hollow rod and chambered scavenger piston, means forming a transfer port adapted to permit the movement of the fuel charge around the scavenger piston, said transfer port communicating at two points with the working cylinder, a valve controlling each communication of the transfer port, an exhaust valve commanding an exhaust passage from the working cylinder, and devices for periodically operating the exhaust valve, the transfer port valves and the valve controlling the fuel admission to the said closed chamber. 75
2. In an internal combustion engine, the combination of a working cylinder, a piston operating therein, an automatic valve controlling a port in the piston, said valve opening into the working cylinder, a closed chamber at the outer side of the working piston, a valve controlling the fuel admission port in the closed chamber, said valve opening said chamber, a scavenger piston free in the working cylinder, the working cylinder having a transfer port communicating therewith at two points and adapted to permit the passage of the working charge around the scavenger piston, a valve commanding each end of the transfer port, a valve commanding an exhaust passage from the working cylinder, and means for periodically operating the transfer port valves, the exhaust valve and the valve controlling the admission of fuel charge into the said closed chamber. 80 85 90 95 100 105 110
3. In an internal combustion engine, the combination of a working cylinder, a working piston operating therein, a valve controlling a port in the piston and opening into the working cylinder, a closed chamber at the outer side of the working piston, a valve opening said chamber and controlling the fluid supply thereto, a scavenger piston free in the working cylinder, the working cylinder having a transfer port communicating therewith at two points and adapted to control the passage of the fuel charge around the scavenger piston, a slide valve commanding the end of the transfer port removed from the working cylinder head, a puppet valve commanding the end of the transfer port adjacent to the cylinder head and opening into the working cylinder, and a valve controlling an exhaust passage from the working cylinder. 115 120 125
4. An internal combustion engine having a working cylinder, a working piston, a free scavenging piston operating in the cylinder between the working piston and combustion chamber, means for introducing the working charge between the two pistons at the end of the working stroke, the cylinder having an exhaust port in the combustion chamber and a transfer port adapted to lead the charge around the scavenging piston into the combustion chamber, an automatic valve commanding the discharge end of the transfer port and seating against combustion chamber pressure, a valve commanding the inlet end of the transfer port, an exhaust valve, and means for mechanically operating the two valves last named. 130 135 140
5. An internal combustion engine having a working cylinder, a working piston, a free scavenging piston operating in the cylinder between the working piston and combustion chamber, means for introducing the working charge between the two pistons at the end of the working stroke, 140

the cylinder having an exhaust port in the combustion chamber and a transfer port adapted to lead the charge around the scavenging piston into the combustion chamber, an automatic valve commanding the discharge end of the transfer port and seating against combustion chamber pressure, a valve commanding the inlet end of the transfer port, an exhaust valve, means for mechanically operating the two valves last named, and an additional valve commanding a port to the atmosphere located in the trans-

fer port intermediate the ends thereof, said valve seating 10 against pressure in the transfer port.

In testimony whereof I have signed my name to this specification in the presence of two subscribing witnesses.

HORATIO G. WOOD.

Witnesses:

WM. M. HAMILTON,  
F. COPE WHITEHOUSE.