

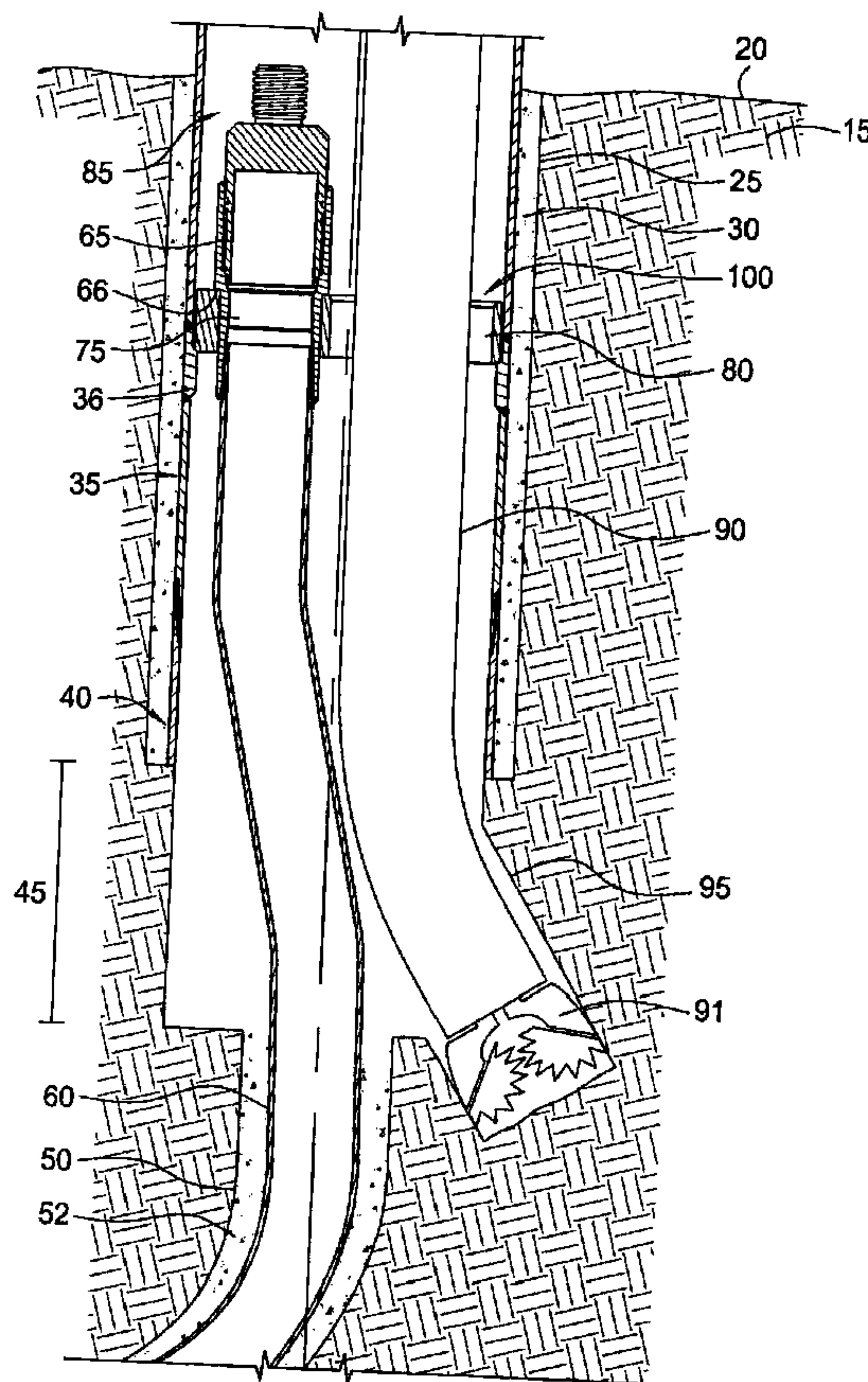

(22) Date de dépôt/Filing Date: 2004/10/04
 (41) Mise à la disp. pub./Open to Public Insp.: 2005/04/03
 (45) Date de délivrance/Issue Date: 2010/02/23
 (30) Priorité/Priority: 2003/10/03 (US60/508,743)

(51) Cl.Int./Int.Cl. *E21B 7/04* (2006.01),
E21B 23/12 (2006.01), *E21B 33/047* (2006.01),
E21B 43/30 (2006.01), *E21B 7/06* (2006.01)
 (72) Inventeurs/Inventors:
 GLASER, MARK C., US;
 ALLEN, JACK R., US;
 FERGUSON, GERALD M., US;
 ALVAREZ, RALPH A., US
 (73) Propriétaire/Owner:
 WEATHERFORD/LAMB, INC., US
 (74) Agent: RIDOUT & MAYBEE LLP

(54) Titre : METHODE DE FORAGE ET DE COMPLETION DE Puits MULTIPLES A L'INTERIEUR D'UN CAISSON
 UNIQUE
 (54) Title: METHOD OF DRILLING AND COMPLETING MULTIPLE WELLBORES INSIDE A SINGLE CAISSON



(57) Abrégé/Abstract:

A method and apparatus for drilling and completing multiple wellbores from a single drilling rig and from within a single wellhead is provided. In one embodiment, a template is disposed at a predetermined location downhole within a casing. In one aspect, a first

(57) **Abrégé(suite)/Abstract(continued):**

casing string is lowered with the template to the predetermined location and disposed within a first wellbore. A second wellbore may be drilled through a bore in the template. A second casing string may then be lowered through the bore into the second wellbore. In another embodiment, at least two wellbores are drilled and completed from a surface casing having a crossover portion.

ABSTRACT OF THE DISCLOSURE

A method and apparatus for drilling and completing multiple wellbores from a single drilling rig and from within a single wellhead is provided. In one embodiment, a template is disposed at a predetermined location downhole within a casing. In one aspect, a first casing string is lowered with the template to the predetermined location and disposed within a first wellbore. A second wellbore may be drilled through a bore in the template. A second casing string may then be lowered through the bore into the second wellbore. In another embodiment, at least two wellbores are drilled and completed from a surface casing having a crossover portion.

METHOD OF DRILLING AND COMPLETING MULTIPLE WELLBORES INSIDE A SINGLE CAISSON

CROSS-REFERENCE TO RELATED APPLICATIONS

[0001] This application contains subject matter that is related to subject matter described in United States patent No. 7,264,067, issued September 4, 2007.

BACKGROUND OF THE INVENTION

Field of the Invention

[0002] Embodiments of the present invention generally relate to drilling and completing wellbores. More specifically, embodiments of the present invention relate to drilling and completing wellbores from within a wellhead.

Description of the Related Art

[0003] In conventional well completion operations, a wellbore is formed to access hydrocarbon-bearing formations by the use of drilling. In drilling operations, a drilling rig is supported by the subterranean formation. A rig floor of the drilling rig is the surface from which casing strings, cutting structures, and other supplies are lowered to form a subterranean wellbore lined with casing. A hole is located in a portion of the rig floor above the desired location of the wellbore.

[0004] Drilling is accomplished by utilizing a cutting structure, preferably a drill bit, that is mounted on the end of a drill support member, commonly known as a drill string. To drill within the wellbore to a predetermined depth, the drill string is often rotated by a top drive or rotary table on the drilling rig, or by a downhole motor mounted towards the lower end of the drill string.

[0005] After drilling to a predetermined depth, the drill string and drill bit are removed and a section of casing is lowered into the wellbore. Casing isolates the wellbore from the formation, preventing unwanted fluids such as water from flowing from the formation into the wellbore. An annular area is thus formed between the string of casing and the formation. The casing string is at least temporarily hung from the surface of the well. A cementing operation may then be conducted in order to fill the annular area with cement. Using apparatus known in the art, the casing string may be cemented into the wellbore by circulating cement into the annular area defined

between the outer wall of the casing and the borehole. The combination of cement and casing strengthens the wellbore and facilitates the isolation of certain areas of interest in the formation behind the casing for the production of hydrocarbons.

[0006] As an alternative to the conventional method, drilling with casing is a method often used to place casing strings of decreasing diameter within the wellbore. This method involves attaching a cutting structure in the form of a drill bit to the same string of casing which will line the wellbore. Rather than running a cutting structure on a drill string, the cutting structure or drill shoe is run in at the end of the casing that will remain in the wellbore and be cemented therein. Drilling with casing is often the preferred method of well completion because only one run-in of the working string into the wellbore is necessary to form and line the wellbore per section of casing placed within the wellbore.

[0007] After the wellbore has been lined with casing to the desired depth, the casing is perforated at an area of interest within the formation which contains hydrocarbons. The hydrocarbons flow from the area of interest to the surface of the earth formation to result in the production of the hydrocarbons. Typically, hydrocarbons flow to the surface of the formation through production tubing inserted into the cased wellbore.

[0008] Drilling and completing each wellbore typically requires a separate drilling rig, a separate wellhead, and separate associated drilling equipment per wellbore. A wellhead is usually located at the surface of each wellbore, below the drilling rig, and may include facilities for installing a casing hanger for use during well completion operations. The casing may be suspended from the casing hanger during various stages of the well completion by use of a gripping arrangement of slips and packing assemblies (e.g., packing rings). The wellhead also usually includes production equipment such as a production tubing hanger for suspending production tubing, means for installing the valve system used during production operations ("Christmas tree"), and/or means for installing surface flow-control equipment for use in hydrocarbon production operations.

[0009] A blowout preventer stack ("BOP stack") is often connected to the top of the wellhead and located below the drilling rig to prevent uncontrolled flow of reservoir fluids into the atmosphere during wellbore operations. The BOP stack includes a

valve at the surface of the well that may be closed if control of formation fluids is lost. The design of the BOP stack allows sealing around tubular components in the well, such as drill pipe, casing, or tubing, or sealing around the open hole wellbore. A sealing element is typically elastomeric (e.g., rubber) and may be mechanically squeezed inward to seal drill pipe, casing, tubing, or the open hole. In the alternative, the BOP stack may be equipped with opposed rams.

[0010] Historically, one assembly per well drilled and completed, the assembly including a drilling rig, wellhead, and associated drilling and wellhead equipment, has been utilized at multiple surface locations. Therefore, a wellhead and BOP stack must be installed for each well with each drilling rig. Utilizing multiple drilling rigs with their associated wellheads and BOP stacks over the surface of the earth incurs additional cost per drilling rig. The expenditures for each drilling rig, wellhead, and associated equipment; the purchase of and preparation of the additional surface land necessary per drilling rig; and the requirement for additional personnel to install and operate each assembly represent the increased costs. Additionally, safety concerns arise with each drilling rig and wellhead utilized for drilling and completion of a wellbore.

[0011] To increase safety and reduce cost per wellbore, it has been suggested that one drilling rig and associated wellhead may be utilized to drill and complete multiple wellbores. When one drilling rig is utilized to complete multiple wellbores, the drilling rig must be moved to each new location to drill and complete each well. Each moving of the drilling rig and wellhead incurs additional cost and provides additional safety risks. At each new location to which the drilling rig is moved, the wellhead must be removed from the old location and then re-installed at the new location by drilling, thus providing additional cost and safety concern per well drilled. Translating the position of the drilling rig and wellhead also requires removing the BOP stack and other drilling equipment from the old location, and then "rigging down" the drilling equipment, including the BOP stack, at the new location. Changing drilling rig position further requires otherwise preparing the wellhead for drilling and completion operations at the location to which the wellhead is moved, such as "tying back" the casing within the wellbore to the surface by connecting a casing string to the casing so that a sealed fluid path exists from the casing to the

surface. Furthermore, any change in position of the drilling rig provides the risk of a blowout, spillage, or other safety breach due to disturbance of wellbore conditions.

[0012] A recent development in drilling and completing multiple wellbores from one drilling rig and associated wellhead involves directionally drilling the wellbores from one drilling rig and wellhead from proximate surface locations. Directional drilling may be utilized to deviate the direction and orientation of each wellbore so that the multiple wellbores do not intersect. If the wellbores are prevented from intersecting, each wellbore becomes a potentially independent source for hydrocarbon production, often from multiple areas of interest or hydrocarbon production zones.

[0013] Because of regulations permitting a limited number of drilling platforms which may be utilized to drill offshore wells, wellbores are often deviated from vertical to increase the amount of wells which may be drilled from a single platform. When drilling an offshore wellbore, a preformed template may be used to guide the location and diameter of the wellbores drilled from the drilling rig. The wellbores are drilled from the template along the well paths dictated by the template to the desired depths.

[0014] Directionally drilling the wellbores from one drilling rig and wellhead at proximate surface locations does not alleviate the inherent safety and economic problems which arise with moving the drilling rig and, consequently, the wellhead, as described above. The current apparatus and methods for drilling multiple wellbores from the nearby locations still require at least slight movement of the drilling rig and associated wellhead along the surface. Even slight movement, e.g. 6-8 inches of movement, of the drilling rig along the surface, often termed "skidding the rig", imposes the additional costs and safety risks involved in removing the wellhead and BOP stack from the first location and "rigging down" the drilling rig, including preparing the wellhead and the BOP stack, for subsequent operations at the second location.

[0015] There is therefore a need for a method and apparatus for drilling and completing multiple wellbores from one drilling rig and wellhead without moving the drilling rig or wellhead. There is a further need for an apparatus and method which provides a decrease in the land, cost, and time necessary to drill and complete

multiple wellbores. There is a further need for an apparatus and method for completing multiple deviated wellbores from one drilling rig and associated wellhead without moving the drilling rig. There is a yet further need for a more aesthetically and environmentally pleasing method for drilling and completing multiple wellbores.

SUMMARY OF THE INVENTION

[0016] In one aspect, the present invention provides a method for drilling multiple wellbores into an earth formation using one wellhead. The method comprises: providing casing extending downhole from a surface of the earth formation; drilling a first wellbore below the casing; and lowering a template connected to a first casing string to a predetermined depth within the casing the template having at least two bores therein.

[0017] In another aspect, the present invention provides a method for drilling multiple wellbores from a single wellhead. The method comprises providing a wellhead at a surface of an earth formation and a casing within the earth formation; drilling a first wellbore below the casing; lowering a template having a first casing string located therethrough from the wellhead to a predetermined depth within the casing while locating the first casing string within the first wellbore; and drilling and casing a second wellbore below the casing through the template.

BRIEF DESCRIPTION OF THE DRAWINGS

[0018] So that the manner in which the above recited features of the present

invention can be understood in detail, a more particular description of the invention, briefly summarized above, may be had by reference to embodiments, some of which are illustrated in the appended drawings. It is to be noted, however, that the appended drawings illustrate only typical embodiments of this invention and are therefore not to be considered limiting of its scope, for the invention may admit to other equally effective embodiments.

[0019] Figure 1 is a cross-sectional view of surface casing of a first embodiment of the present invention within a wellbore.

[0020] Figure 2 is a cross-sectional view of the surface casing of Figure 1. The wellbore is shown extended below the surface casing, and a first wellbore is being drilled into the formation from the extended wellbore.

[0021] Figure 3 is a cross-sectional view of a first casing string disposed within the first wellbore of Figure 2. The first casing string is disposed in a first slot in a template.

[0022] Figure 3A shows a downward view of the template along line 3A-3A of Figure 3.

[0023] Figure 4 shows a plug connected to an upper end of the first casing string of Figure 3.

[0024] Figure 5 is a cross-sectional view of the surface casing with the first casing string disposed within the first wellbore of Figure 3. A second wellbore is drilled through a second slot in the template.

[0025] Figure 6 shows the first casing string disposed within the first wellbore and a second casing string disposed within the second wellbore.

[0026] Figure 7 shows a casing string connected to the upper end of the first casing string.

[0027] Figure 8 shows the second casing string and the casing string connected to the upper end of the first casing string engaged by a dual hanger within a wellhead.

[0028] Figure 9 is a sectional view of surface casing of a second embodiment of the present invention disposed within a wellbore.

[0029] Figure 10 shows a first wellbore drilled below the surface casing of Figure 9.

[0030] Figure 11 shows a first casing disposed within the first wellbore and a diverting tool being lowered into the surface casing of Figure 9.

[0031] Figure 12 shows the diverting tool located within the surface casing of Figure 9.

[0032] Figure 13 shows a second wellbore drilled from the surface casing of Figure 9.

[0033] Figure 14 shows the diverting tool being retrieved from the surface casing of Figure 9.

[0034] Figure 15 shows a tie-back casing operatively connected to the upper end of the first casing.

[0035] Figure 16 shows a second casing disposed within the second wellbore.

[0036] Figure 17 is a sectional view of surface casing of a third embodiment of the present invention disposed within a wellbore.

[0037] Figure 18 shows a first wellbore drilled below the surface casing of Figure 17 and a first casing disposed within the first wellbore. A diverting tool is being lowered into the surface casing.

[0038] Figure 19 shows the diverting tool located within the surface casing of Figure 17.

[0039] Figure 20 shows a tie-back casing operatively connected to the upper end of the first casing and a second wellbore drilled from the surface casing of Figure 17.

[0040] Figure 21 shows a second casing being lowered into the second wellbore through the surface casing of Figure 17.

[0041] Figure 22 is a cross-sectional view of an embodiment of the tie-back casing of Figure 15 disposed within the surface casing.

[0042] Figure 23 is a sectional view of an embodiment of the tie-back casing of Figure 15 having a deflector disposed thereon.

[0043] Figure 24 shows an embodiment of a deflector usable with the tie-back casing of Figure 15.

[0043A] Figure 25 shows the first casing string disposed within the first wellbore, the second casing string disposed within the second wellbore and a third casing string disposed within a third wellbore.

DETAILED DESCRIPTION OF THE PREFERRED EMBODIMENT

[0044] The apparatus and methods of the present invention allow multiple wellbores to be drilled into the formation with one drilling rig and wellhead. Drilling multiple wellbores from one drilling rig and wellhead reduces the cost and time expended, as well as increases the safety of the drilling and completion of the wellbores by decreasing the amount of equipment necessary to drill and complete each wellbore, decreasing the amount of personnel necessary for operations related to each wellbore, and decreasing the amount of land necessary to reach the hydrocarbons by drilling the wellbores. Additionally, drilling multiple wellbores from one drilling rig and wellhead decreases the surface area occupied by visible well equipment, so that more wells may be drilled from a smaller area using common equipment, thus providing a more aesthetically pleasing land surface in the environment.

[0045] Multiple wellbores may be drilled with the present invention from one location without removing the wellhead and BOP stack from the old location, moving the drilling rig from the old location to the new location, and then re-installing the wellhead and the BOP stack at the new location. The ability to form multiple wellbores from one drilling rig and wellhead without skidding the rig eliminates the cost of "rigging down" and otherwise preparing the BOP stack and the wellhead, as well as increases safety at the well site due to decreased instances of upsetting the balance of the well by moving the drilling rig. Furthermore, the ability to form multiple wellbores from one drilling rig and wellhead without moving the drilling rig

reduces environmental concerns that may arise from moving the drilling rig to multiple locations, such as the potential for spillage and/or blowouts.

[0046] The present invention allows for only one rigging down of the drilling rig, wellhead, and BOP stack during drilling, completion, and production of multiple wellbores. Furthermore, the present invention eliminates additional preparation of the wellsite which ensues when multiple wellbores are drilled from multiple locations.

[0047] The discussion below focuses primarily on drilling two wellbores from one drilling location without moving the drilling equipment. The principles of the present invention also allow for the formation of multiple wellbores from one drilling location using one drilling rig and wellhead without moving the drilling rig or wellhead.

[0048] A first embodiment of the present invention is shown in Figures 1-8. Figure 1 shows a wellhead 10 located at a surface 20 of a wellbore 25 formed within an earth formation 15. A drilling rig (not shown) is located above the wellhead 10 to allow lowering of equipment through the wellhead 10 from the drilling rig. A BOP stack (not shown) is preferably connected to the upper portion of the wellhead 10 to prevent blowouts and other disturbances. The wellhead 10 has dual adapters 11 located opposite from one another across the wellhead 10.

[0049] Surface casing 35 extends from within the wellhead 10 into the wellbore 25. The surface casing 35 preferably has an outer diameter of approximately 16 inches, although the surface casing 35 diameter is not limited to this size. When drilling more than two wellbores from within the surface casing 35, the surface casing may be approximately 36 inches in outer diameter or greater. The surface casing 35 may include one or more casing sections threadedly connected to one another.

[0050] A cement shoe 40 may be threadedly connected to a lower end of the surface casing 35, although it is not necessary to the present invention. The cement shoe 40 aids in cementing the surface casing 35 within the wellbore 25, as a check valve (not shown) disposed within the cement shoe 40 allows cement to pass downward through the surface casing 35 and out through the check valve, but prevents cement

flow back up through the surface casing 35 to the surface 20. In Figure 1, cement 30 is shown within the annulus between the surface casing 35 and the wellbore 25. The cement 30 and the cement shoe 40 are consistent with one embodiment of the present invention. In another embodiment, the surface casing 35 is retained in place within the wellbore 25 for subsequent operations by hangers within the wellhead 10 or other means known by those skilled in the art to suspend tubulars at a position within the wellbore.

[0051] The surface casing 35 has an upset portion 36 which provides a restricted inner diameter within the surface casing 35. The upset portion 36 may be included in another piece of equipment in the surface casing 35, including but not limited to the float shoe 40. The upset portion 36 may include at least two tabs extending inward from the inner diameter of the surface casing 35, or the upset portion 36 may include a circumferential inner diameter restriction extending inward from the inner diameter of the surface casing 35. The inner diameter restriction may include any mechanism capable of retaining a template 100, as shown in Figure 3 and described below. It is also contemplated that the template 100 may be retained at the desired location within the surface casing 35 by means other than an inner diameter restriction, including but not limited to one or more pins or a threadable connection.

[0052] Figure 2 shows the surface casing 35 cemented within the wellbore 25. Although Figures 2-7 do not show the wellhead 10 shown in Figure 1, the wellhead 10 exists above the surface casing 35 in all of the figures. In Figure 2, a portion of the cement shoe 40 remains threadedly connected to the surface casing 35, but a lower end of the cement shoe 40 has been drilled out with a drill string (not shown) which is used to drill an extended wellbore portion 45. The extended wellbore portion 45 preferably approaches the inner diameter of the surface casing 35; however, it is contemplated that the extended wellbore portion 45 may be of any diameter through which two wellbores (deviated or non-deviated wellbores) may be drilled, as described below. The extended wellbore portion 45 provides room for manipulating the casing strings (see below) to allow placement of the casing strings into the deviated wellbores at the correct orientation, according to the process described below.

[0053] A drill string 55 is shown in Figure 2 drilling a first wellbore 50. A cutting structure 56, including but not limited to a drill bit, is used to drill through the formation 15 to form the first wellbore 50. A portion of the first wellbore 50 is shown drilled out by the cutting structure 56.

[0054] Figure 3 shows a template 100 located on the upset portion 36 within the surface casing 35. The upset portion 36 is preferably disposed at a depth of approximately 1-2000 feet so that the template 100 is finally located to rest on the upset portion 36 at that depth. A first casing string 60 is located within the template 100. The first casing string 60 preferably has an outer diameter of approximately 4½ inches, but the first casing string 60 is not limited to an outer diameter of that size. The first casing string 60 is threadedly connected to a running string 70 by a coupling 65. The running string 70 may be any type of tubular, including but not limited to casing and pipe. The running string 70 may include one or more tubular sections threadedly connected to one another, and the first casing string 60 may include one or more casing sections threadedly connected to one another.

[0055] The coupling 65 has a shoulder 66 extending therefrom to retain the first casing string 60 and the running string 70 in position. The first casing string 60 extends below the template 100, the running string 70 extends above the template 100, and the coupling 65 extends above and below the template 100 and within a first slot 75 in the template 100. The first slot 75 is a first bore running through the template 100, as shown in Figure 3A. The shoulder 66 of the coupling 65 rests on the template 100. It is also contemplated that any portion of the first casing string 60 may be retained with the template 100 using any other apparatus or method known to those skilled in the art.

[0056] The running string 70 extends to the surface 20 and up into the wellhead 10 (see Figure 1). The first casing string 60 extends through the surface casing 35, through the extended wellbore 45, and into the first wellbore 50. Cement 52 is shown in the annulus between the first casing string 60 and the first wellbore 50. The cement 52 may extend above the annulus between the first casing string 60 and the first wellbore 50 into the annulus between the first casing string 60 and the extended wellbore 45, and even into the annulus between the first casing string 60

and the surface casing 35. It is also contemplated that the first casing string 60 does not have to be cemented into the first wellbore 50.

[0057] A downward view of the template 100 along line 3A—3A of Figure 3 is shown in Figure 3A. The first slot 75 has the coupling 65 located therein. Funnels 76 and 77 are mounted on the template 100 around the first slot 75 to guide the orientation of the first casing string 60 to allow it to deviate into the first wellbore 50 (shown in Figure 3). Any number of funnels 76 and 77 may be employed to guide and angle the first casing string 60 into the first wellbore 50. The funnels 76 and 77 are disposed at the distance from the first slot 75 and at angles with respect to the first slot 75 calculated to guide and angle the first casing string 60 into the first wellbore 50.

[0058] Figure 3A also shows a second slot 80 on the template 100. The second slot 80 is a second bore running through the template 100. The second slot 80 is shown as having a larger diameter than the first slot 75, but it is also contemplated to be of the same diameter as the first slot 75 or of a smaller diameter than the first slot 75. Preferably, the diameter of the second slot 80 is larger than the diameter of the first slot 75 so that a large enough drill string 90 may be inserted through the second slot 80 to drill a second wellbore 95 of a desired diameter for inserting a second casing string 105 of the desired size (see Figures 5-6), as described below in relation to Figures 5-6. The second slot 80 has funnels 81 and 82 mounted around it on the template 100 to guide the orientation of the second casing string 105 (see Figures 6-7). As with the funnels 76 and 77, any number of funnels 81 and 82 may be used, and the funnels 81 and 82 may be disposed at the distance and the angle with respect to the second slot 80 contemplated to guide and angle the second casing string 105 into the second wellbore 95. Lugs 115 and 120 may be located near the outer diameter of the template 100 on opposing sides of the template 100.

[0059] Figure 4 shows the running string 70 of Figure 3 replaced with a plug 85. The plug 85 prevents debris from entering the first casing string 60 during subsequent operations.

[0060] Figure 5 shows a drill string 90 with a cutting structure 91, preferably a drill bit, attached thereto drilling a second wellbore 95 into the formation 15. The drill string 90 is placed through the second slot 80.

[0061] Figure 6 shows a second casing string 105 located within the second slot 80, through the surface casing 35, through the extended wellbore 45, and into the second wellbore 95. The second casing string 105 preferably has an outer diameter of 4 ½ inches, although the outer diameter of the second casing string 105 is not limited to this size. Cement 106 is shown occupying the annulus between the second wellbore 95 and the second casing string 105, as well as within the portion of the surface casing 35 and the extended wellbore 45 which is not occupied by the first casing string 60 or the second casing string 105. The cement 106 may be allowed to rise to any level within the second wellbore 95, the extended wellbore 45, or the surface casing 35, and is not required to rise up to the template 100, as shown in Figure 6. Additionally, it is contemplated that the present invention is operable without cement 106, as well as without cement 30 or 52.

[0062] Figure 7 shows the first and second casing strings 60 and 105 disposed within the first and second wellbores 50 and 95. The plug 85 has been removed, and a casing string 110 has been connected to the first casing string 60 by the coupling 65. The casing string 110 may include one or more casing sections threadedly connected to one another. The casing string 110 extends to the surface 20 of the wellbore 25.

[0063] Figure 8 shows a dual hanger 67 within the wellhead 10. Disposed within the dual hanger 67 are sealing element 61, which is used to sealingly engage the casing string 110, and sealing element 62, which is used to seal around the second casing string 105. The sealing elements 61 and 62 are preferably packing elements. Also disposed within the dual hanger 67 are gripping elements 63 and 64. The gripping element 63 is used to grippingly engage the casing string 110, while the gripping element 64 is utilized to grippingly engage the second casing string 105. The gripping elements 63 and 64 preferably include slips.

[0064] Seals 71A-B are disposed between the dual hanger 67 and the casing string 110. Seals 72A-B are disposed between the dual hanger 67 and the second casing

string 105. Seals 73A-B are disposed between the upper portion of the portion 67A of the dual hanger 67 housing the casing string 110 and the wellhead 10, while seals 74A-B are disposed between the upper portion of the portion 67B of the dual hanger 67 housing the second casing string 105 and the wellhead 10. Seals 79A-B are disposed between the lower portion of the dual hanger 67 and the inner surface of the wellhead 10. The seals 71A-B, 72A-B, 73A-B, 74A-B, and 79A-B may include any type of seal, including for example o-rings. The seals 71A-B, 72A-B, 73A-B, 74A-B, and 79A-B function to isolate the casing strings 110 and 105 from one another as well as seal between the dual hanger 67 and the wellhead 10. Any number of seals may be utilized with the present invention.

[0065] In operation, the wellhead 10 is placed below the drilling rig and above the desired location for drilling wellbores. The BOP stack and various other wellhead equipment are installed on or in the wellhead 10. A drill string (not shown) is inserted from the drilling rig and through the wellhead 10 into the formation 15 to drill the wellbore 25 (see Figure 1) into the formation 15. The drill string is then removed from the wellbore 25 to the surface 20 when the wellbore 25 is of a sufficient depth to insert the surface casing 35 to the desired depth. Next, as shown in Figure 1, the surface casing 35 is inserted into the wellbore 25. The surface casing 35 is hung by hangers (not shown) located within the wellhead 10, or by other means known by those skilled in the art. Optionally, the surface casing 35 may be set within the wellbore 25 by placing cement 30 within the annulus between the surface casing 35 and the wellbore 25. When utilized, and as shown in Figure 1, the cement 30 is introduced into the inner diameter of the surface casing 35 and flows through the cement shoe 40, then up through the annulus between the surface casing 35 and the wellbore 25.

[0066] In an alternate embodiment which is not shown, the surface casing 35 may be utilized to drill the wellbore 25. In this embodiment, rather than the cement shoe 40 being located at the lower end of the surface casing 35, an earth removal member, preferably a drill bit, is operatively connected to the lower end of the surface casing 35. The surface casing 35 drills into the formation 15 to the desired depth, then cement may optionally be introduced into the annulus between the surface casing 35 and the wellbore 25. Drilling with the surface casing 35 allows

forming of the wellbore 25 and placing the surface casing 35 into the formation 15 to be consolidated into one step, so that the wellbore 25 is drilled and the surface casing 35 is simultaneously placed within the formation 15.

[0067] After the surface casing 35 is placed within the wellbore 25 at the desired location, a drill string (not shown) may be inserted into the surface casing 35. The drill string is preferably capable of drilling an extended wellbore 45 which possesses a diameter at least as large as the inner diameter of the surface casing 35. The extended wellbore 45 is shown in Figure 2. When using a cement shoe 40, the drill string drills through the lower portion of the cement shoe 40 to form the extended wellbore 45. Also, if any cement 40 exists below the surface casing 35, the drill string drills through this cement. When drilling with the surface casing 35, the earth removal member may be drillable by the drill string. The drill string is then removed from the extended wellbore 45 and the wellbore 25. For the present invention, the extended wellbore 45 is included in a preferable embodiment, but is not necessary in all embodiments, as the first and second wellbores 50 and 95 may be drilled from a lower end of the surface casing 35.

[0068] Next, as shown in Figure 2, the drill string 55 with the cutting structure 56 attached thereto is used to drill the first wellbore 50 into the formation 15. The cutting structure 56 is preferably capable of drilling a smaller diameter hole than the drill string used to drill the extended wellbore 45. The first wellbore 50 may be drilled from any portion of the extended wellbore 45. In the alternative, the first wellbore 50 may be drilled from the lower end of the surface casing 35 in the absence of the extended wellbore 45. In Figures 2-7, the first wellbore 50 is drilled from a central portion of the extended wellbore 45 for purposes of illustration only. Figure 2 shows the first wellbore 50 being drilled into the formation 15 by the drill string 55.

[0069] The cutting structure 56 is preferably a drill bit capable of directionally drilling to alter the trajectory of the first wellbore 50. The drill string 55 may then deviate the first wellbore 50 to reach the area of interest within the formation 15, such as the area which contains hydrocarbons for recovering. For example, the cutting structure 56 may be a jet deflection bit (not shown), the structure and operation of which is known to those skilled in the art. Alternatively, pads (not shown) may be placed on the drill string 55 to bias the drill string 55 and alter its orientation. Any other known

apparatus or method known to those skilled in the art may be utilized to alter the trajectory of the first wellbore 50.

[0070] After drilling the first wellbore 50 to the desired depth, the drill string 55 is removed from the first wellbore 50, extended wellbore 45, and wellbore 25. Referring now to Figure 3, prior to running the template 100 into the wellbore 25, an upper end of the first casing string 60 is coupled to a lower end of the running string 70 by the coupling 65. The first casing string 60 and running string 70 connected by the coupling 65 is placed within the first slot 75 of the template 100 until the shoulder 66 of the coupling 65 rests on the template 100, thus preventing further movement of the coupling 65, first casing string 60, and running string 70 through the first slot 75.

[0071] Next, the template 100 having the first casing string 60 disposed therein is lowered into the surface casing 35. The lugs 115 and 120 help orient the template 100 within the surface casing 35 while the template 100 is being run into the surface casing 35, so that the slots 75 and 80 are in the desired position, namely the position at which the casing strings 60 and 105 may be manipulated into their respective wellbores 50 and 95. Any number of lugs 115 and 120 may be utilized to orient the template 100, including just one lug. Furthermore, no lugs may be employed if desired. Any other type of anti-rotation device may be utilized with the present invention to prevent rotation of and orient the template 100.

[0072] As is evident in Figure 3, even when the template 100 is oriented correctly within the surface casing 35 by the lugs 115 and 120, due to directional drilling the entirety of the first wellbore 60 may not be in longitudinal line with the first slot 75 and the first casing string 60 that is disposed within the first slot 75 (although the present invention also includes drilling a first wellbore 50 which is directly below the first slot 75). The funnels 76 and 77 aid in manipulating the first casing string 60 through the portion of the surface casing 35 below the upset portion 36 and through the extended wellbore 45 so that the first casing string 60 is guided to enter into the first wellbore 50. The first casing string 60 is preferably flexible enough to allow for manipulation of the first casing string 60 to allow it to travel into and through the first wellbore 50 at an angle. After the first casing string 60 initially enters the first

wellbore 50, the first casing string 60 follows the deviation of the drilled first wellbore 50 as the first casing string 60 is further lowered into the first wellbore 50.

[0073] The template 100 with the first casing string 60 located therein is lowered into the surface casing 35 until the outer portion of the template 100 rests on the upset portion 36 of the surface casing 35. The outer surface of the portion of the template 100 which will rest of the upset portion 36 is larger than the inner surface of the upset portion 36, so that the template 100 cannot travel into the wellbore 25 to a further depth than the upset portion 36. The lugs 115 and 120 maintain the template 100 at the correct orientation and prevent the template 100 from rotating while the template 100 is lowered into position. Furthermore, the lugs 115 and 120 maintain the template 100 in the desired position and prevent rotating of the template 100 relative to the surface casing 35 once the template 100 is stopped on the upset portion 36. Accordingly, the template 100 suspends the first casing string 60 in position downhole at a predetermined depth.

[0074] Once the template 100 is placed on the upset portion 36, cement 52 may be provided within the annulus between the first casing string 60 and the first wellbore 50. To provide cement 52 within the annulus, cement 52 is introduced into the running string 70, then flows through the first casing string 60, out through the lower end (not shown) of the first casing string 60, and up through the annulus between the first casing string 60 and the first wellbore 50. Figure 3 shows cement 52 throughout the annulus between the first casing string 60 and the first wellbore 50, ending at the extended wellbore 45. In the alternative, the cement 52 may only partially fill the annulus, may be allowed to fill a portion or all of the annulus between the first casing string 60 and the extended wellbore 45, or may be allowed to fill a portion or all of the annulus between the first casing string 60 and the surface casing 35 and/or cement shoe 40. Cement 52 is not necessary to the present invention; therefore, it is also contemplated that the first casing string 60 is not cemented into the first wellbore 50 during the operation of the present invention.

[0075] Upon placement of the template 100 on the upset portion 36 and the optional cementing of the first casing string 60 into the wellbore 50, the running string 70 is unthreaded from the coupling 65 by any means known to those skilled in the art, including a top drive or a rotary table and tongs. The lugs 115 and 120 act as an

anti-rotation device to prevent the first casing string 60 from rotating while the running string 70 rotates, so that the running string 70 rotates relative to the first casing string 60. The running string 70 is removed from the wellbore 25.

[0076] The plug 85 may then be threaded onto the coupling 65, as shown in Figure 4. The plug 85 prevents debris from polluting the first casing string 60 during subsequent operations involving forming the second wellbore 95. The lugs 115 and 120 act as an anti-rotation device while the apparatus for providing torque rotates and threads the plug 85 onto the coupling 65. Figure 4 shows the plug 85 threadedly connected to the coupling 65. The plug 85 is used in a preferable embodiment of the present invention, but it is also contemplated that the present invention may proceed without use of the plug 85.

[0077] Next, referring to Figure 5, the drill string 90 is inserted into the surface casing 35. The drill string 90, including the cutting structure 91, may be the same as or different from the drill string 55 and cutting structure 56 utilized to drill the first wellbore 50, with respect to diameter of the wellbore which the drill string 90 is capable of drilling as well as other aspects. Preferably, the drill string 90 and cutting structure 91 are configured to directionally drill a deviated second wellbore 95, as described above in relation to the drill string 90 and cutting structure 91. The larger diameter of the second slot 80 relative to the first slot 75 allows the drill string 90 and cutting structure 91 to pass through the second slot 80. As stated above, the first wellbore 50 is drilled prior to the presence of the template 100, so the drill string 55 and cutting structure 56 outer diameters are not limited to the diameter of the first slot 75.

[0078] Figure 5 shows the drill string 90 drilling a second wellbore 90 which is deviated outward relative to the first wellbore 50 at an angle. The second wellbore 90 may be drilled from any portion of the extended wellbore 45 at any angle with respect to vertical. The second wellbore 90 is not required to be deviated at an angle. If desired, the second wellbore 90 may be drilled downward in line with the second slot 80. The drill string 90 is then removed from the second wellbore 95, the extended wellbore 45, and the surface casing 35.

[0079] Referring to Figure 6, the second casing string 105 is placed within the

surface casing 35 and through the second slot 80. The funnels 81 and 82 guide and orient the second casing string 105 to place the second casing string 105 into position to enter the second wellbore 95. The second casing string 105 is manipulated to angle into the second wellbore 95. The extended wellbore 45 allows room for manipulation of the orientation of the first casing string 60 and the second casing string 105 when inserting and lowering the first and second casing strings 60 and 105 within their respective wellbores 50 and 95.

[0080] After the second casing string 105 is lowered into the second wellbore 95 to the desired depth, cement 106 may be introduced into the second casing string 105. The cement 106 flows through the second casing string 105, out the lower end (not shown) of the second casing string 105, and up through the annulus between the second casing string 105 and the second wellbore 95. Just as with the first casing string 60 within the first wellbore 50 described above, the cement 106 may alternately only partially fill the annulus between the second casing string 105 and the second wellbore 95, or the cement 106 may be allowed to fill a portion or all of the extended wellbore 45, cement shoe 40, and/or surface casing 35. Cement 106 is not necessary if some other means of suspending the second casing string 105 in place within the second wellbore 95 is utilized. Further, as shown in Figure 25, a third casing string 130 may be placed in a third wellbore 135 in a similar manner as described herein.

[0081] Finally, the plug 85 is removed by unthreading the threadable connection between the lower end of the plug 85 and the upper end of the coupling 65. The casing string 110 is threaded onto the coupling 65 by threadedly connecting the lower end of the casing string 110 to the upper end of the coupling 65. In this manner, the first casing string 60 is "tied back" to the surface 20 by the casing string 110, which allows fluid communication through the first casing string 60 to the surface 20 for subsequent wellbore operations, including hydrocarbon production operations.

[0082] Figure 8 shows the final step in the operation of an embodiment of the present invention. After the first casing string 60 is tied back to the surface 20, sealing elements 61 and 62, preferably packers, and gripping elements 63 and 64, preferably slips, within the dual casing hanger 67 may be activated to grip upper

portions of the casing string 110 and the second casing string 105. At this point, the casing strings 60 and 105 are preferably approximately 7.7 inches apart, as measured from the central axis of the first casing string 60 to the central axis of the second casing string 105, and the template 100 is preferably configured to induce this amount of separation. As measured from the center of the dual hanger 67, the distance to the central axis of the second casing string 105 is preferably approximately 3.85 inches. It is contemplated that the first and second casing strings 60 and 105 may be any distance apart from one another, so the present invention is not limited to the above preferable distance measurements. As an alternative to using the dual hanger 67 to hang the casing strings 60 and 105, the casing strings 60 and 105 may be hung by including a coupling with a shoulder of each casing string rather than using the sealing elements 61 and 62 and the gripping elements 63 and 64 to hang the casing strings 60 and 105. Any known method of suspending the casing strings 60 and 105 known to those skilled in the art may be utilized in lieu of the dual casing hanger 67.

[0083] The first and/or second wellbores 50 and 95 may then be completed by using packers (not shown) to straddle one or more areas of interest within the formation 15. Perforations are formed through the first and/or second casing strings 60 and 105, the cement 52 and/or 106, and the area of interests within the formation 15. Hydrocarbon production operations may then proceed.

[0084] A second embodiment of the present invention, shown in Figures 9-16, also involves drilling and completing two wellbores below the same wellhead without moving the wellhead. A surface casing 210 is shown in Figure 9 disposed within a wellbore 220 formed in an earth formation 205. Although the wellhead is not shown, the surface casing 210 extends from the wellhead, and the wellhead is located above the wellbore 220 and within a blowout preventer (not shown). The surface casing 210 is set within the wellbore 220, preferably by a physically alterable bonding material such as cement 225. Cement 225 preferably extends through at least a portion of the annulus between the outer diameter of the surface casing 210 and a wall of the wellbore 220. In the alternative, one or more hanging tools or other hanging mechanisms known to those skilled in the art may be utilized to set the surface casing 210 within the wellbore 220.

[0085] The surface casing 210 includes a first casing portion 210A, second casing portion 210B, crossover casing portion 210C, and third casing portion 210D. A float shoe (not shown) having a one-way valve may optionally be located at a lower end of the third casing portion 210D to facilitate cementing of the surface casing 210 within the wellbore 220. Casing portions 210A, 210B, 210C, and 210D are operatively connected to one another, and may be threadedly or otherwise connected to one another. Preferably, the lower end of the first casing portion 210A is connected to the upper end of the second casing portion 210B, the lower end of the second casing portion 210B is connected to the upper end of the crossover casing portion 210C, and the lower end of the crossover casing portion 210C is connected to the upper end of the third casing portion 210D.

[0086] The first casing portion 210A has a first inner diameter. Preferably, the first casing portion 210A diameter is approximately 13 3/8-inch, with a drift diameter of approximately 12 1/4 inches and an inner diameter of approximately 12.415 inches, although the first casing portion 210A diameter is not limited to this size. Also, the first casing portion 210A is preferably 1000 feet in length, although the casing portion 210A may extend any length. The second casing portion 210B has an inner diameter which is preferably substantially the same as the first inner diameter. The second casing portion 210B is drillable, preferably constructed of a fiberglass material, to allow drilling of a second wellbore 260 therethrough (see Figure 13). The fiberglass material also allows communication of signals of logging-while-drilling, measurement-while-drilling, or other steering tools therethrough while drilling a second wellbore 280 (see description of operation below).

[0087] The crossover casing portion 210C has an inner diameter at its upper end which is preferably substantially the same as the first inner diameter. After extending at the first inner diameter for a length, one side of the wall of the crossover casing portion 210C angles inward at angled portion 212 so that the crossover casing portion 210C eventually becomes a second, smaller inner diameter and extends at this second inner diameter for a length to form a leg from the surface casing 210. Therefore, the crossover casing portion 210C forms an off-centered crossover, where the centerline of the maximum inner diameter portion of the surface casing 210 is not coaxial with the centerline of the minimum inner diameter

portion of the surface casing 210. The third casing portion 210D extends from the lower end of the crossover portion 210C and has an inner diameter substantially the same as the second inner diameter. The third casing portion 210D, although not limited to this size, is preferably 8 5/8-inches in diameter.

[0088] Figure 10 shows a first wellbore 230 extending from the wellbore 220. The first wellbore 230 is preferably a hole of 7 7/8-inches in diameter drilled into the earth formation 205, but the hole may be of any diameter. As shown, the first wellbore 230 extends in a direction away from the centerline of the third casing portion 210D. It is also within the scope of the present invention that the first wellbore 230 may extend substantially vertically or at any other trajectory away from the centerline of the third casing portion 210D.

[0089] Also shown in Figure 10 is a drill string 235 capable of forming the first wellbore 230 within the formation 205 by drilling into the earth formation 205. The drill string 235 includes generally a running tool connected to a drill bit 240, wherein the drill bit 240 includes any earth removal member known to those skilled in the art. One or more measurement devices may be located on the drill string to allow determination and optimization of the orientation and trajectory of the drill string 235 within the formation 205 while drilling, including any logging-while-drilling tools or measuring-while-drilling tools, or any other steering tools known to those skilled in the art.

[0090] Additional components are shown in Figure 11. A running string 255 capable of conveying a diverting tool 250 into the wellbore 220 is shown operatively connected to the diverting tool 250. The diverting tool 250 is capable of diverting or guiding a mechanism or tubular body at an angle from the centerline of the first inner diameter portion of the surface casing 210.

[0091] Preferably a whipstock, the diverting tool 250 is specially shaped to conform with the shape of the crossover casing portion 210C of the surface casing 210 and to prevent rotation of the diverting tool 250 relative to the surface casing 210. The angled portion 212 of the inner diameter of the surface casing 210 in which the surface casing 210 changes from the first inner diameter to the smaller, second inner diameter and the angled portion 252 of the diverting tool 250 have

substantially the same slopes to mate with one another when the diverting tool 250 rests on the angled portion 212. Additionally, the side 251 of the diverting tool 250 opposite the angled portion 212 is essentially longitudinal to conform with the generally longitudinally disposed inner wall of that side of the surface casing 210 inner diameter.

[0092] An extending end 253 of the diverting tool 250 is generally tubular-shaped and of an outer diameter substantially the same as the second inner diameter of the surface casing 210 to allow the extending end 253 to fit within the portion of the surface casing 210 having the second inner diameter, as shown in Figure 12. Referring now to Figure 12, a diverting surface 254 of the diverting tool 250 is angled downward toward the inner diameter of the surface casing 210 at an angle substantially opposite from the angle of the angled portion 252. The diverting surface 254 is used to divert one or more mechanisms or tubular bodies at an angle from the surface casing 210. Threads 256 may be located at an upper end of the diverting surface 254 for mating with opposing threads (not shown) of the running string 255 so that the running string 255 may convey the diverting tool 250 into the wellbore 220 (see Figure 11). Any other connecting means known to those skilled in the art may be utilized to connect the diverting tool 250 to the running string 255, and any type of running tool known to those skilled in the art may be utilized as the running string 255.

[0093] As shown in both Figures 11 and 12, a first casing 245 is located within the first wellbore 230 and may be at least partially cemented therein using cement 232 or another physically alterable bonding material within the annulus between the outer diameter of the first casing 245 and the wall of the first wellbore 230. A float shoe (not shown) having a one-way valve may optionally be located at a lower end of the first casing 245 to facilitate cementing.

[0094] A hanging mechanism such as a liner hanger 247 may be utilized to initially hang the first casing 245 within the first wellbore 230 prior to cementing. In the alternative, the liner hanger 247 may be utilized to hang the first casing 245 within the first wellbore 230 in lieu of cementing. The liner hanger 247 is shown hanging the first casing 245 by engaging the inner diameter of the third casing portion 210D

of the surface casing 210, but the liner hanger 247 may also be used to hang the first casing 245 from the wall of the first wellbore 230.

[0095] Figure 13 shows a second wellbore 260 extending from the surface casing 210. The drill string 235 may be utilized to drill the second wellbore 260. The second wellbore 260 is shown deviating at an angle away from the centerline of the surface casing 210, but may extend vertically therefrom or at any other angle away from vertical.

[0096] Referring now to Figure 15, a lower end of tie-back casing 270 is operatively connected to an upper end of the first casing 245, possibly through the liner hanger 247. The tie-back casing 270 is preferably 4 ½-inch diameter liner, but may be of any size. Proximate to the juncture between the surface casing 210 and the second wellbore 260, a deflector 275 extends from an outer diameter of the side of the casing 270 closest to the second wellbore 260. The deflector 275 has an angled deflecting surface 276 for deflecting any mechanisms, tools, or tubulars desired for placement within the second wellbore 260 from the surface casing 210. Specifically, the deflecting surface 276 may be capable of deflecting a second casing 280 into the second wellbore 260, as shown in Figure 16.

[0097] Figure 23 is a section view of an embodiment of the portion of the tie-back casing 270 having the deflector 275 thereon. The deflector 275 is operatively attached to the tie-back casing 270. Figure 23 shows one method of attaching the deflector 275 to the tie-back casing 270 using one or more clamping mechanisms 277, 278. The clamping mechanisms 277, 278 secure the deflector 275 to the tie-back casing 270 as well as establish the rotational and axial position of the deflector 275 relative to the tie-back casing 270. The clamping mechanisms 277, 278 are preferably fixed onto the tie-back casing 270 with set screws 293A, 293B (shown in Figure 22, which is described below) and most preferably are approximately 4 inches wide.

[0098] A support member such as a support gusset 294 preferably extends below the deflector 275 to provide additional mechanical strength to the deflector 275. Preferably, the maximum width of the deflector 275 is approximately the same as the maximum width of the support gusset 294, and most preferably this width is 5

inches. The deflecting surface 276 of the deflector member 275 is preferably 10 inches long, and the angle θ at which the deflecting surface 276 extends from the outer length of the tie-back casing 270 is approximately 30 degrees.

[0099] Figure 24 shows an alternate embodiment of a deflecting mechanism usable as the deflector 275. In this embodiment, a stop collar is placed around the tie-back casing 270. The stop collar includes one or more collars 288A, 288B connected to one another by a longitudinally disposed deflector 286 and a longitudinally disposed blade 242. The deflector 286 and the blade 242 are preferably substantially parallel to one another and disposed approximately 180 degrees apart from one another on an outer diameter of the collars 288A, 288B. The collars 288A, 288B each include hinges 289A, 289B which allow the collars 288A, 288B to open so that ends 244A and 244B and ends 243A and 243B move away from one another, thereby permitting placement of the stop collar on the tie-back casing 270. Hinges 289A, 289B also allow the collars 288A, 288B to close so that ends 244A, 244B and 243A, 243B contact one another and the stop collar may be securely placed around the tie-back casing 270.

[00100] The deflector 286 extends in the direction of the second wellbore 260, while the blade 242 extends in the opposite direction towards the inner diameter of the surface casing 210. The blade 242 and the deflector 286 generally operate as a centralizer for the tie-back casing 270. Although any width is within the scope of embodiments of the present invention, the deflector 286 most preferably has a maximum width (measured perpendicular from the outer diameter of the tie-back casing 270) of approximately 5 inches, while most preferably the blade 242 has a maximum width of approximately 1 1/2 inches. Most preferably, the thickness (measured generally parallel to the outer diameter of the tie-back casing 270) of the blade 242 as well as the deflector 286 is approximately 1 inch, although any thickness is in the scope of embodiments of the present invention.

[00101] At the upper and lower ends, the blade 242 is preferably angled to slope downward at the upper end and upward at the lower end. The lower end of the deflector 286 is also preferably angled to slope upward, as shown in Figure 24. The upper end of the deflector 286 is sloped downward in the direction of the second wellbore 260 to provide a deflecting surface 287 for guiding the second casing 280

into the second wellbore 260. Most preferably, the deflecting surface 287 and the lower end of the deflector 286 are angled approximately 30 degrees with respect to the outer diameter of the collars 288A, 288B. The deflecting surface 287 is preferably concave (the concave deflecting surface may be formed using the inside, concave surface of a tubular) to prevent the second casing 280 from falling from the deflecting surface 287 while it is being manipulated into the second wellbore 260.

[00102] Figure 16 shows the second casing 280 disposed within the second wellbore 260. The second casing 280 may optionally be set within the second wellbore 260 by a physically alterable bonding material at least partially disposed within the annulus between the outer diameter of the second casing 280 and the wall of the second wellbore 260, or instead may be hung within the second wellbore 260 by any other hanging mechanism known to those skilled in the art. A float shoe (not shown) having a one-way valve may optionally be located at a lower end of the second casing 280 to facilitate cementing.

[00103] In operation, the surface casing portions 210A, 210B, 210C, and 210D are operatively connected to one another, and the wellbore 220 is formed in the earth formation 205 using an earth removal member (not shown) such as a drill bit operatively connected to a drill string (not shown). The surface casing 210 is lowered into the wellbore 220 and set within the wellbore 220, preferably by introducing cement 225 into at least a portion of the annulus, as shown in Figure 9. To flow cement 225 into the annulus between the outer diameter of the surface casing 210 and the wall of the wellbore 220, cement 225 is introduced into an inner diameter of the surface casing 210, then the cement 225 flows out the lower end of the surface casing 210 (possibly out the float shoe) and up into the annulus. Instead of using cement 225, any casing-hanging mechanism known to those skilled in the art may be utilized to set the surface casing 210 within the wellbore 220.

[00104] Figure 9 depicts the surface casing 210 set within the wellbore 220. As shown in Figure 9, the crossover casing portion 210C is positioned within the wellbore so that the angled portion 212 is oriented in the direction in which it is desired to form the second wellbore 260 (see Figure 13).

[00105] After the surface casing 210 is set within the wellbore 220, the drill string 235 (see Figure 10) is lowered into an inner diameter of the surface casing 210. The drill string 235, including the drill bit 240, is smaller in outer diameter than the drill string (not shown) used to form the wellbore 220 so that the drill string 235 fits within the inner diameter of the surface casing 210. The drill string 235, including the drill bit 240, is also smaller in outer diameter than the inner diameter of the third casing portion 210D to allow the drill string 235 to fit through the third casing portion 210D and drill a first wellbore 230 therebelow.

[00106] The drill string 235 is lowered into the inner diameter of the third casing portion 210D and out through the lower end of the third casing portion 210D to drill the first wellbore 230 within the formation 205 using the drill bit 240. The angled portion 212 acts to guide the drill string 235 into the second, minimum inner diameter portion of the crossover casing portion 210C. The third casing portion 210D and the second inner diameter portion of the crossover casing portion 210C act to guide the drill string 235 into the portion of the formation 205 in which the first wellbore 230 is desired to be formed.

[00107] The drill bit 240 forms the first wellbore 230 below the surface casing 210 as shown in Figure 10. The trajectory of the first wellbore 230 may be altered by manipulating the direction and angle of the drill string 235 within the formation 205. The direction in which the angle of the drill string 235 should be manipulated may be communicated by one or more logging-while-drilling or measuring-while drilling tools or any other steering tool known by those skilled in the art. Preferably, the first wellbore 230 is deviated in the opposite direction from the angled portion 212, as shown in Figure 10, to avoid co-mingling of the first and second wellbores 230, 260 (see Figure 13). However, it is also within the scope of embodiments of the present invention to form the first wellbore 230 substantially co-axial to the third casing portion 210D along its entire length, or to form the first wellbore 230 at any angle with respect to the centerline of the third casing portion 210D.

[00108] After the first wellbore 230 is formed, the drill string 235 is removed from the surface casing 210. Figure 10 shows the drill string 235 being removed from the surface casing 210.

[00109] Referring to Figure 11, the first casing 245 is lowered into the inner diameter of the surface casing 210. The angled portion 212 acts as a guide for the first casing 245 into the second inner diameter portion of the crossover casing portion 210C. The liner hanger 247 is used in the conventional manner to hang the first casing 245 from the lower end of the surface casing 210. After running the first casing 245 into the first wellbore 230, the first casing 245 may optionally be cemented therein by flowing cement 232 into the inner diameter of the surface casing 210. The cement 232 then flows through the inner diameter of the first casing 245, out the lower end of the first casing 245 (and possibly out through the float shoe), and into an annulus between the outer diameter of the first casing 245 and the wall of the first wellbore 230. Cement 232 may partially or completely fill the annulus.

[00110] After cementing the first casing 245 within the first wellbore 230, a plug (not shown) may be run into the inner diameter of the first casing 245 to prevent debris from entering the first casing 245 when subsequently forming the second wellbore 260. The plug may be any mechanism capable of obstructing access from the portion of the inner diameter of the first casing 245 above the plug to the portion of the inner diameter of the first casing 245 below the plug. For example, the plug may be a bridge plug or a plug set in a nipple known by those skilled in the art. The diverting tool 250 is then lowered into the inner diameter of the surface casing 210 using a running string 255 (or any other running tool known by those skilled in the art).

[00111] To orient the diverting tool 250 correctly within the surface casing 210, the diverting tool 250 is positioned with respect to the surface casing 210 prior to entering the surface casing 210 so that the angled portion 252 of the diverting tool 250 is oriented directly in line with the angled portion 212 of the crossover casing portion 210C. If the position of the angled portion 212 within the wellbore 220 is unknown, the diverting tool 250 may be lowered with the angled portion 252 at a given rotational position. If the orientation of the diverting tool 250 is incorrect at this rotational position, the diverting tool 250 will not attain a deep enough depth within the surface casing 210. If the diverting tool 250 is in the wrong position for the extending end 253 to enter the crossover casing portion 210C, the running string

255 will not lower to a sufficient depth, so that the running string 255 may be lifted and the diverting tool 250 re-oriented within the surface casing 210. Thus, a trial-and-error process may be utilized when orienting the diverting tool 250 with respect to the surface casing 210. Figure 11 shows the diverting tool 250 being lowered into the surface casing 210, where the angled portion 252 of the diverting tool 250 is directly in line with the angled portion 212 of the crossover casing portion 210C.

[00112] In an alternate embodiment, a geometrically-shaped object having a profile (such as a square profile) may be located between the maximum and minimum inner diameter portions of the surface casing 210, or within the leg. A matching profile (such as a square profile) is then disposed on a side of the diverting tool 250. In this embodiment, the extending end 253 of the diverting tool 250 is not necessary to prevent rotation of the diverting tool 250 relative to the surface casing 210. The profile of the diverting tool 250 and the profile of the geometrically-shaped object mate with one another to prevent rotation of the diverting tool 250 relative to the surface casing 210 and to allow proper orientation of the diverting tool 250 within the surface casing 210. The mating profiles may be splines on the diverting tool 250 which match splines on the geometrically-shaped object in lieu of matching square profiles. Also in this embodiment, if the diverting tool 250 does not reach a sufficient depth within the surface casing 210, the profiles must not be matching at that rotational position of the diverting tool 250, so the diverting tool 250 is lifted and re-oriented. This process may be repeated any number of times until the diverting tool 250 reaches a sufficient depth within the surface casing 210.

[00113] The diverting tool 250 is ultimately positioned on the crossover casing portion 210C as illustrated in Figure 12. The angled portion 252 of the diverting tool 250 is in contact with the angled portion 212 of the crossover casing portion 210C, and the extending end 253 of the diverting tool 250 fits into the inner diameter of the smallest diameter portion of the crossover casing portion 210C and the third casing portion 210D. Preferably, when the diverting tool 250 is in position within the surface casing 210 for forming the second wellbore 260, the second casing portion 210B is substantially adjacent to the diverting surface 254 of the diverting tool 250. The diverting tool 250 is prevented from rotational movement relative to the surface casing 210 because the extending end 253 locks the diverting tool 250 into radial

position, and the angled diverting surface 254 and angled portion 252 are too large in outer diameter to rotate around the side of the surface casing 210 having the leg extending therefrom while the extending end 253 remains in the leg.

[00114] After the diverting tool 250 is positioned within the crossover casing portion 210C as shown in Figure 12, the running string 255 is removed from the surface casing 210, preferably by unthreading the running string 255 from the threads 256 of the diverting tool 250 and lifting the running string 255 from the surface casing 210. Figure 12 shows the diverting tool 250 in position for diverting a tool in the general direction of the downward slope of the diverting surface 254 using the diverting surface 254 as a guide for the tool.

[00115] Next, referring to Figure 13, the drill string 235 having the drill bit 240 operatively connected thereto is lowered into the inner diameter of the surface casing 210. Once the drill bit 240 reaches the diverting surface 254 of the diverting tool 250, the drill bit 240 cannot travel directly downward anymore and is guided over the diverting surface 254 into the inner diameter of the side of the second casing portion 210B above the lower end of the diverting surface 254 of the diverting tool 250. The drill bit 240 then drills through at least a portion of the second casing portion 210B, through the cement 225 surrounding the second casing portion 210B, and into the formation 205 to form the second wellbore 260. Because the diverting surface 254 is used as a guide for the angle in which the second wellbore 260 will be drilled, the diverting tool 250 is preferably formed to produce the desired second wellbore 260 trajectory by providing a given slope along the diverting surface 254 prior to its insertion into the wellbore 220. The second wellbore 260 may be directionally drilled to alter or maintain the trajectory of the second wellbore 260 using one or more logging-while-drilling or measuring-while-drilling tools, or any other steering tool known to those skilled in the art, as described above in relation to drilling the first wellbore 230.

[00116] After drilling the second wellbore 260, the drill string 235 is removed from the second wellbore 260 and from the wellbore 220. Figure 13 shows the drill string 235 being removed from wellbore 220.

[00117] Subsequent to removing the drill string 235 from the wellbore 220, the running string 255 is lowered into the surface casing 210 and operatively connected to the diverting tool 250, preferably by a threaded connection. The running string 255 is then lifted to remove the diverting tool 250 from the wellbore 220. Figure 14 shows the running string 255 used to lift the diverting tool 250 from the wellbore 220.

[00118] The tie-back casing 270 used to tie the first casing 245 back to up to the surface of the wellbore 220 is then lowered into the inner diameter of the surface casing 210. A lower end of the tie-back casing 270 is operatively connected to an upper end of the first casing 245, preferably by a threaded connection. The deflector 275 is oriented in line with the second wellbore 260. The slope of the deflecting surface of the deflector 275 is preferably substantially similar to the slope of the deflecting surface 254 of the diverting tool 250 to allow tools to be diverted by the deflector 275 into the same wellbore which was drilled using the deflecting surface 254. The location of the deflector 275 on the tie-back casing 270 may be pre-determined prior to the location of the tie-back casing 270 into the wellbore 220 to allow the deflector 275 to act as an extension to the second wellbore 260, or this location may be attained by placing the deflector 275 on the tie-back casing 270 after the tie-back casing 270 is already located downhole.

[00119] The second casing 280 is then lowered into the inner diameter of the surface casing 210 (see Figure 16) between the outer diameter of the tie-back casing 270 and the inner diameter of the surface casing 210 generally in line with the hole from the surface casing 210 leading to the second wellbore 260. The deflector 275 guides the second casing 280 into the second wellbore 260. Optionally, cement 283 may be introduced into the inner diameter of the second casing 280, out the lower end of the second casing 280 (and possible the float shoe), and into the annulus between the outer diameter of the second casing 280 and the wall of the second wellbore 260 to set the second casing 280 within the second wellbore 260. Cement 283 may partially or completely fill the annulus. In the alternative, a hanging tool may be utilized to set the second casing 280 within the second wellbore 260. After setting the second casing 280 within the second wellbore 260, the plug is retrieved from the inner diameter of the first casing 245 through the tie-back casing 270.

[00120] Figure 16 shows the resulting multi-lateral wellbore consistent with embodiments of the present invention. By the method described above using apparatuses as described above, two independent cased wellbores 260 and 280 are formed from one drilled wellbore 220 from the surface without moving the wellhead disposed above the wellbore 220. As viewed from the surface, the wellbore 220 has only one casing 210 therein; however, as depth of the wellbore 220 increases, the wellbore 220 branches into two independently-producing, completed wells.

[00121] Figures 17-21 depict a third embodiment of the present invention. In this embodiment, the surface casing 310 is substantially the same as the surface casing 210. The difference between the surface casings 210 and 310 is that the surface casing 310 includes a built-in deflector member 307 extending from the inner diameter of the crossover casing portion 310C of the surface casing 310 below the second casing portion 310B on the wall of the surface casing 310 through which the second wellbore 360 is drilled. Therefore, a deflector is integral with the off-centered crossover casing portion, thus eliminating the need for a deflector on the tie-back casing, as is present in the embodiments of Figures 17-21.

[00122] Referring generally to Figure 17, the deflector member 307 has a deflecting surface 308 angled downward in the direction in which the second wellbore 360 is to be deflected (see Figure 20). The deflector member 307 includes a substantially longitudinal, flat outer surface 309.

[00123] A diverting tool 395, shown in Figures 18 and 19, is essentially shaped the same as the diverting tool 250, except that the diverting tool 395 has a smaller maximum width than the diverting tool 250, the maximum width of the diverting tool 395 measured from a first side 363 to a second side 361. A deflecting surface 358 of the diverting tool 395 is shorter than the deflecting surface 250 because of the reduced width of the diverting tool 395. The reduced width of the diverting tool causes space to exist between the inner diameter of the surface casing 310 and the outer diameter of the diverting tool 395, which space is filled with the deflector member 307 when the diverting tool 395 reaches a position within the crossover casing portion 310C (see Figure 19). In this manner, the diverting tool 395 and deflector member 307 mate to form a unified deflecting surface for deflecting one or more tools and/or tubulars in the direction of the second wellbore 360.

[00124] In one embodiment, the outer surface 309 of the deflector member 307 is concave to receive the rounded first side 363 of the diverting tool 395. In another embodiment, the outer surface 309 of the deflector member 307 is flat, and the outer surface of the first side 363 of the diverting tool 395 is sliced off and flat (not tubular-shaped). In yet another embodiment, the first side 363 of the diverting tool 395 and the outer surface 309 of the adjacent side of the deflector member 307 include mating profiles, such as mating geometric shapes (e.g., square profiles) or mating splines. When the outer surface 309 of the adjacent side of the deflector member 307 and the first side 363 of the diverting tool 395 are flat or have mating profiles, the extending end 362 is not necessary to prevent rotation of the diverting tool 395 relative to the surface casing 310, as the mating profiles or flat surfaces prevent rotation of the diverting tool 395 relative to the surface casing 310. The flat surfaces or mating profiles further allow orientation within the surface casing 310 of the diverting tool 395. If the diverting tool 395 is prevented from lowering to a sufficient depth within the surface casing 310 because the profiles are not correctly aligned with one another, the diverting tool 395 is lifted, re-oriented relative to the surface casing 310, and again lowered into the surface casing 310. This process may be repeated any number of times to fit the profile of the diverting tool 395 into the profile of the deflector member 307.

[00125] As shown in Figure 21, tie-back casing 397 need not include a deflector thereon. A second casing 398 may have a lipstick-shaped guide shoe 399 or bent sub operatively connected to its lower end. The lipstick shape of the guide shoe 399 provides an angled surface which is capable of sliding over the angled, deflecting surface 308, so that the guide shoe 399 angled surface and the deflecting surface 308 are capable of guiding the second casing 398 into the second wellbore 360.

[00126] In the operation of the third embodiment, first in reference to Figure 17, the wellbore 320 is formed in the formation 305, preferably by a drill bit on a drill string (not shown). The drill string is removed from the wellbore 320, and the surface casing 310 is lowered into the wellbore 320. Cement 325 may be introduced to at least partially fill the annulus between the outer diameter of the surface casing 310 and the wall of the wellbore 320 and set the surface casing 310 within the wellbore 320. When lowering the surface casing 310 into the wellbore 320, the side of the

surface casing 310 having the deflector member 307 attached thereto is located in the direction in which the second wellbore 360 (see Figure 20) is eventually desired to be formed.

[00127] A drill string (not shown) having a drill bit operatively connected to its lower end is then lowered into the inner diameter of the surface casing 310 and guided over the angled portion 312 into the smallest inner diameter portion of the crossover casing portion 310C and the third casing portion 310D (the leg). The drill bit is then used to drill into the formation 305 below the third casing portion 310D to form the first wellbore 330, shown in Figure 18. The drill string may include one or more logging-while-drilling or measuring-while-drilling tools, or any other steering tools known to those skilled in the art, for altering the trajectory of the first wellbore 330 while drilling.

[00128] After drilling the first wellbore 330, the drill string is removed from the first wellbore 330 and from the wellbore 320 to the surface. The first casing 345 is lowered into the inner diameter of the surface casing 310 and into the first wellbore 330. Again, the angled portion 312 of the surface casing 310 guides the first casing 345 into the smallest inner diameter portion of the crossover casing portion 310C, into the third casing portion 310D, and into the first wellbore 330. The first casing 345 may be hung at least temporarily from the inner diameter of the surface casing 310 (as shown in Figure 18) or from the wall of the first wellbore 330 using the liner hanger 347. Optionally, the first casing 345 may then be set within the first wellbore 330 by at least partially filling the annulus between the first casing 345 and the wall of the first wellbore 330 with cement 332.

[00129] Optionally, a plug may be placed in the inner diameter of the first casing 345 at this point in the operation to prevent debris from falling into the first casing 345. The plug may be any mechanism capable of obstructing access from the portion of the inner diameter of the first casing 345 above the plug to the portion of the inner diameter of the first casing 345 below the plug. For example, the plug may be a bridge plug or a plug set in a nipple, as known by those skilled in the art.

[00130] Next, the diverting tool 395 is lowered using a running string 355 or other running tool known to those skilled in the art into the inner diameter of the surface

casing 310, as shown in Figure 18. Because of the existence of the extending end 362 of the diverting tool 395, the diverting tool 395 is forced into position in the crossover casing portion 310C. If the diverting tool 395 is in the wrong position for the extending end 362 to enter the crossover casing portion 310C, the running string 355 will not lower to a sufficient depth, so that the running string 355 may be lifted and the diverting tool 395 re-oriented within the surface casing 310. Figure 18 depicts the diverting tool 395 being lowered into the surface casing 310 and oriented correctly within the crossover casing portion 310C. In its correct orientation within the crossover casing portion 310C, the first side 363 of the diverting tool 395 slides along the side 309 of the deflector member 307.

[00131] Figure 19 shows the diverting tool 395 positioned within the crossover casing portion 310C. Once positioned, the diverting tool 395 is prevented from rotational movement relative to the surface casing 310 for the same reasons as the diverting tool 250 is prevented from rotation relative to the surface casing 210, as described above in relation to Figures 9-16. When the diverting tool 395 is seated on the crossover casing portion 310C, the deflecting surfaces 308 and 358 of the deflector member 307 and the diverting tool 395, respectively, form a unified, generally continuous deflecting surface for deflecting one or more tools and/or tubulars into the direction in which the second wellbore 360 is formed. After the diverting tool 395 is seated in the crossover casing portion 310C, the running string 355 is removed from its connection with the diverting tool 395, thereby exposing threads 356 on the upper end of the diverting tool 395 (if the connection between the running string 355 and diverting tool 395 is threaded).

[00132] A drill string (not shown, but similar to the drill string 235 shown and described in relation to Figure 10) having a drill bit (not shown, but similar to the drill bit 240 shown and described in relation to Figure 10) operatively connected to its lower end is then lowered into the inner diameter of the surface casing 310. The deflecting surface formed by the deflecting surfaces 308 and 358 of the deflector member 307 and the diverting tool 395, respectively, deflects the drill bit into the inner diameter of the side of the surface casing 310 to which the deflector member 307 is attached. The deflecting surface acts as a guide to dictate the direction and orientation of the drill bit when the drill bit is used to form the second wellbore 360.

[00133] The drill bit then drills through the second portion 310B of the surface casing 310, which is constructed of a drillable material, preferably fiberglass. The second wellbore 360, shown in Figure 20, is then formed within the formation 305 from the surface casing 310 using the drill bit. As mentioned above in relation to the first wellbore 330, the drill string may include one or more logging-while-drilling or measuring-while-drilling tools for altering the trajectory of the second wellbore 360. After the second wellbore 360 is formed, the drill string is removed from the second wellbore 360. Figure 20 shows the second wellbore 360 formed in the formation 305 and the drill bit removed.

[00134] Referring again to Figures 18 and 19, the running string 355 is lowered into the surface casing 310 to retrieve the diverting mechanism 395. Next, a tie-back casing 397, which is shown in Figure 20, is lowered into the inner diameter of the surface casing 310, and the lower end of the tie-back casing 397 is operatively connected to the upper end of the first casing 345. The tie-back casing 397 operates to tie the first casing 345 back to the surface and thereby allow communication between the surface and the first wellbore 330 through the first casing 345 and tie-back casing 397. As mentioned above, the tie-back casing 397 is not required to include a deflector thereon for deflecting the second casing 398 (see Figure 21) into the second wellbore 360, as the deflector member 307 is integral to the surface casing 310 and performs this service.

[00135] Figure 20 shows the tie-back casing 397 operatively connected to the first casing 345 and the second wellbore 360 formed. If the plug is disposed within the first casing 345, the plug may be retrieved at this point in the operation.

[00136] Finally, the second casing 398 is lowered into the inner diameter of the surface casing 310, as shown in Figure 21. The second casing 398 is lowered into the surface casing 310 between the outer diameter of the tie-back casing 397 and the inner diameter of the surface casing 310 on the side of the surface casing 310 from which the second wellbore 360 is formed. The angled lower surface of the guide shoe 399 aids in guiding the second casing 398 to slide along the deflecting surface 308 of the deflector member 307.

[00137] Ultimately, the second casing 398 is placed within the second wellbore 360. The second casing 398 may be set within the second wellbore 360 by partially or completely filling the annulus with cement or some other physically alterable bonding material. In lieu of cement, the second casing 398 may be set within the second wellbore 360 by using one or more hanging mechanisms known to those skilled in the art.

[00138] The third embodiment shown and described in relation to Figures 17-21 allows two independent cased wellbores 360, 330 to be formed downhole from only one cased wellbore 320 visible from the surface. These two wellbores 360, 330 are capable of being formed and completed using only one wellhead without moving the wellhead.

[00139] Figure 22 is a cross-sectional view of the tie-back casing 270 with the deflector 275 thereon. The tie-back casing 270 may include blades 291A, 291B having a first length and blades 292A, 292B having a second length longer than the first length. In a preferred, non-limiting embodiment, the blades 291A, 291B, 292A, 292B are constructed of steel, the first length is approximately 1 ½ inches, and the second length is in the range of approximately 4 ½ inches to approximately 5 inches. The blades 291A, 291B, 292A, 292B are preferably spaced apart along the outer diameter of the tie-back casing 270 at approximately 90 degree intervals. These blades 291A, 291B, 292A, 292B are used to position the tie-back casing 270 within the surface casing 210 so that the tie-back casing 270 is located in position above the first casing 245 and a space exists between blades 292A, 292B for inserting a second casing 280. The blades 291A, 291B, 292A, 292B further ensure that the tie-back casing 270 remains radially positioned with respect to the surface casing 210. The blades 292A and 292B include the deflector 275 therebetween, the rounded outer surface of the deflector 275 being generally radially parallel to the inner surface of the surface casing 210. In one embodiment, the deflector 275 is a cut-out portion of a tubular member with the inside concave surface facing upward. Figure 22 shows the concave surface of the deflector 275 using lines on the deflector 275. The concave surface helps to prevent the second casing 280 from falling from the deflecting surface 287 while it is being manipulated into the second wellbore 260.

[00140] Although the surface casing 210, 310 of the above embodiments shown in Figures 9-21 is generally described and shown as being constructed of four portions 210A-D, 310A-D, the surface casing 210, 310 may instead be constructed of only one portion having the general shape of the surface casing 210, 310, or may instead be constructed of any number of portions operatively connected to one another. The portions of the surface casing 210, 310 may be formed from the same materials or different materials.

[00141] While the foregoing is directed to embodiments of the present invention, other and further embodiments of the invention may be devised without departing from the basic scope thereof, and the scope thereof is determined by the claims that follow.

Claims:

1. A method for drilling multiple wellbores into an earth formation using one wellhead, comprising:
 - providing casing extending downhole from a surface of the earth formation;
 - drilling a first wellbore below the casing; and
 - lowering a template connected to a first casing string to a predetermined depth within the casing, the template having at least two bores therein.
2. The method of claim 1, further comprising drilling a second wellbore below the casing through a second bore of the at least two bores in the template.
3. The method of claim 2, further comprising altering the trajectory of at least one of the first and second wellbores while drilling at least one of the first and second wellbores.
4. The method of claim 2, further comprising lowering a second casing string into the second wellbore through the second bore in the template.
5. The method of claim 2, wherein at least one funnel guides the second casing string into the second wellbore.
6. The method of claim 2, wherein the method is accomplished without moving a blowout preventer in a wellhead.
7. The method of claim 2, further comprising drilling a third wellbore below the casing through a third bore of the at least two bores in the template.
8. The method of claim 2, wherein at least one of the first and second wellbores is deviated from vertical.
9. The method of claim 8, further comprising:

drilling an extended wellbore below the casing prior to drilling the first wellbore below the casing; and

deviating at least one of the first and second wellbores from vertical by altering an orientation of a drill string within the extended wellbore, the drill string drilling at least one of the first and second wellbores.

10. The method of claim 2, further comprising plugging the upper end of the first casing string prior to drilling the second wellbore below the casing.

11. The method of claim 10, further comprising:

lowering a second casing string into the second wellbore through the second bore in the template; and

connecting the upper end of the first casing string to the surface to provide a fluid path from the surface to within the first wellbore.

12. The method of claim 1, wherein the predetermined depth within the casing comprises a restricted inner diameter portion of the casing capable of preventing the template from further lowering within the casing.

13. The method of claim 1, wherein an anti-rotation device substantially prevents rotation of the template while lowering the template to the predetermined depth.

14. The method of claim 13, wherein the anti-rotation device comprises at least one lug disposed near an outer diameter of the template.

15. A method for drilling multiple wellbores from a single wellhead, comprising:
providing a wellhead at a surface of an earth formation and a casing within the earth formation;

drilling a first wellbore below the casing;

lowering a template having a first casing string located therethrough from the wellhead to a predetermined depth within the casing while locating the first casing string within the first wellbore; and

drilling and casing a second wellbore below the casing through the template.

16. The method of claim 15, wherein drilling and casing a second wellbore below the casing through the template comprises:
 - drilling the second wellbore through a first bore disposed in the template; and
 - inserting a second casing string through the first bore and into the second wellbore.
17. The method of claim 16, further comprising:
 - drilling a third wellbore through a second bore disposed in the template; and
 - inserting a third casing string through the second bore and into the third wellbore without moving the wellhead.
18. The method of claim 16, further comprising extending the first casing string to the surface by connecting a casing string to an upper end of the first casing string.
19. The method of claim 18, further comprising activating a dual hanger connected to a wellhead to grippingly engage the casing string connected to the first casing string and the second casing string, wherein activating is accomplished without moving the wellhead.
20. The method of claim 15, wherein casing the first wellbore further comprises:
 - introducing cement into an annulus between the first casing string and the first wellbore.
21. The method of claim 15, wherein the first and second wellbore are drilled using one or more drill strings.
22. The method of claim 21, wherein one of the one or more drill strings is inserted through a bore in the template to drill the second wellbore.
23. The method of claim 15, wherein at least one of the first and second wellbores is deviated from vertical.

24. The method of claim 15, further comprising altering a trajectory of the first wellbore while drilling the first wellbore.

25. The method of claim 15, further comprising altering a trajectory of the second wellbore while drilling the second wellbore.

26. The method of claim 15, wherein drilling and casing the first wellbore and the second wellbore is accomplished without moving the wellhead.

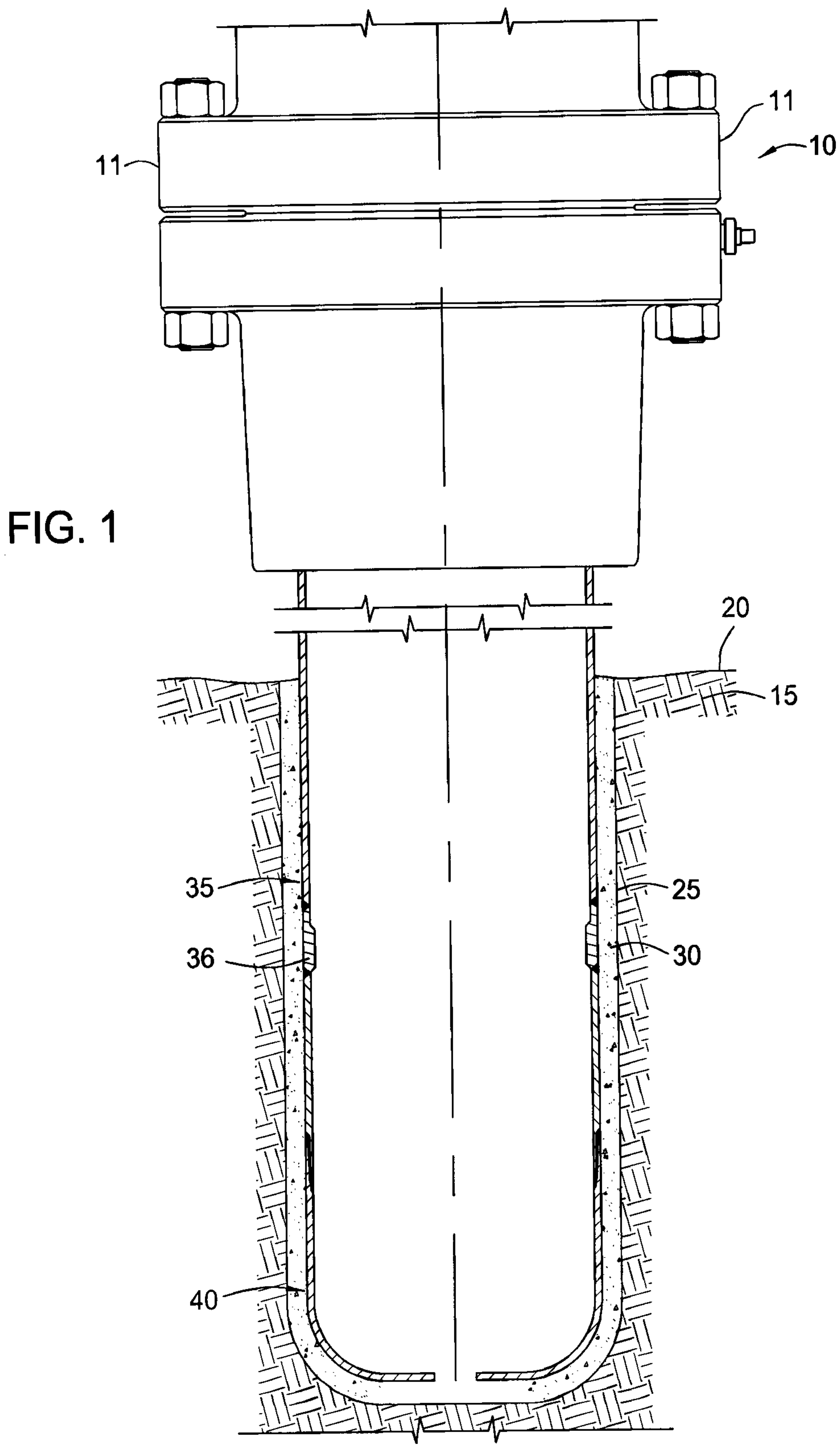

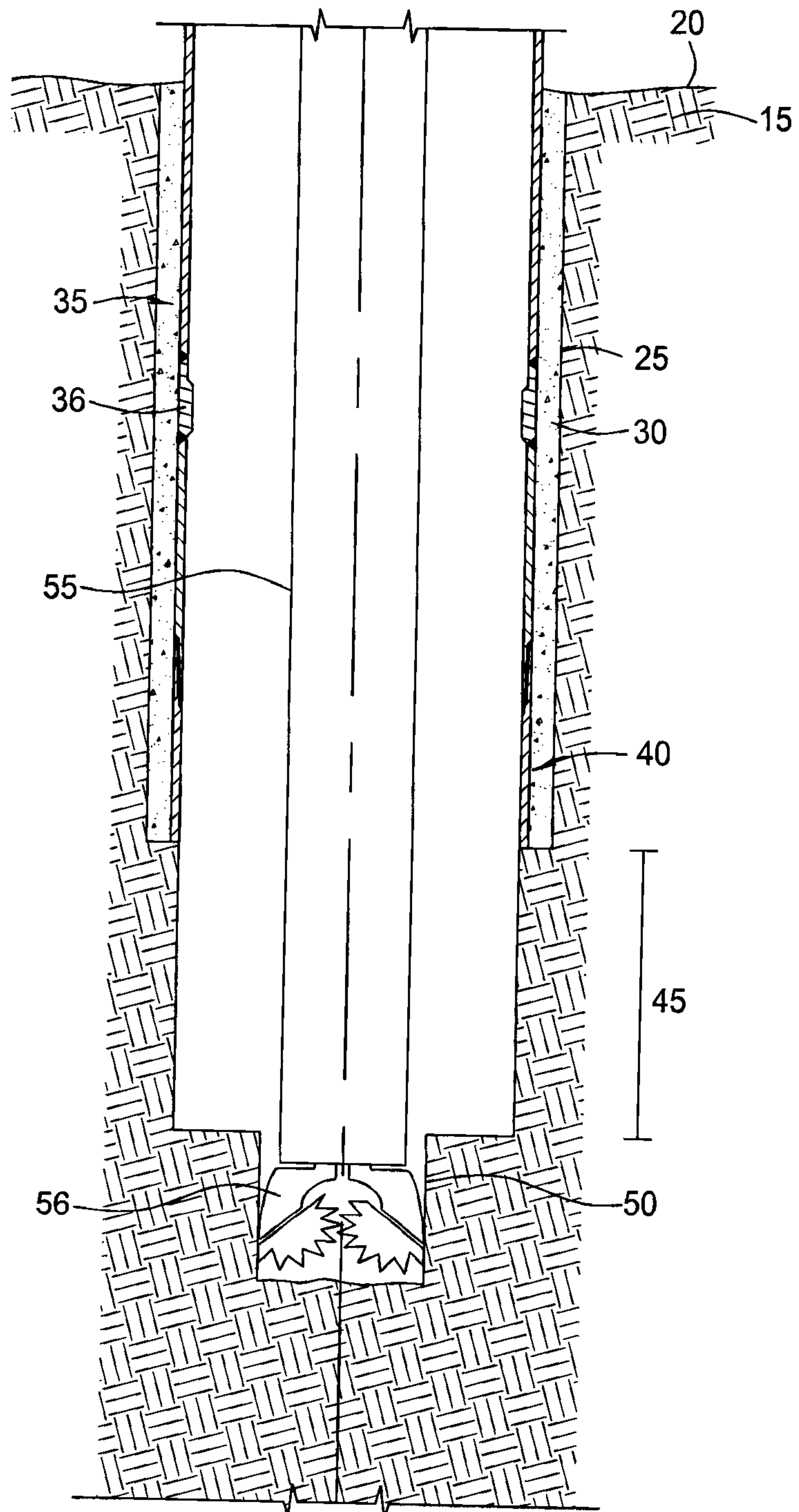

FIG. 2

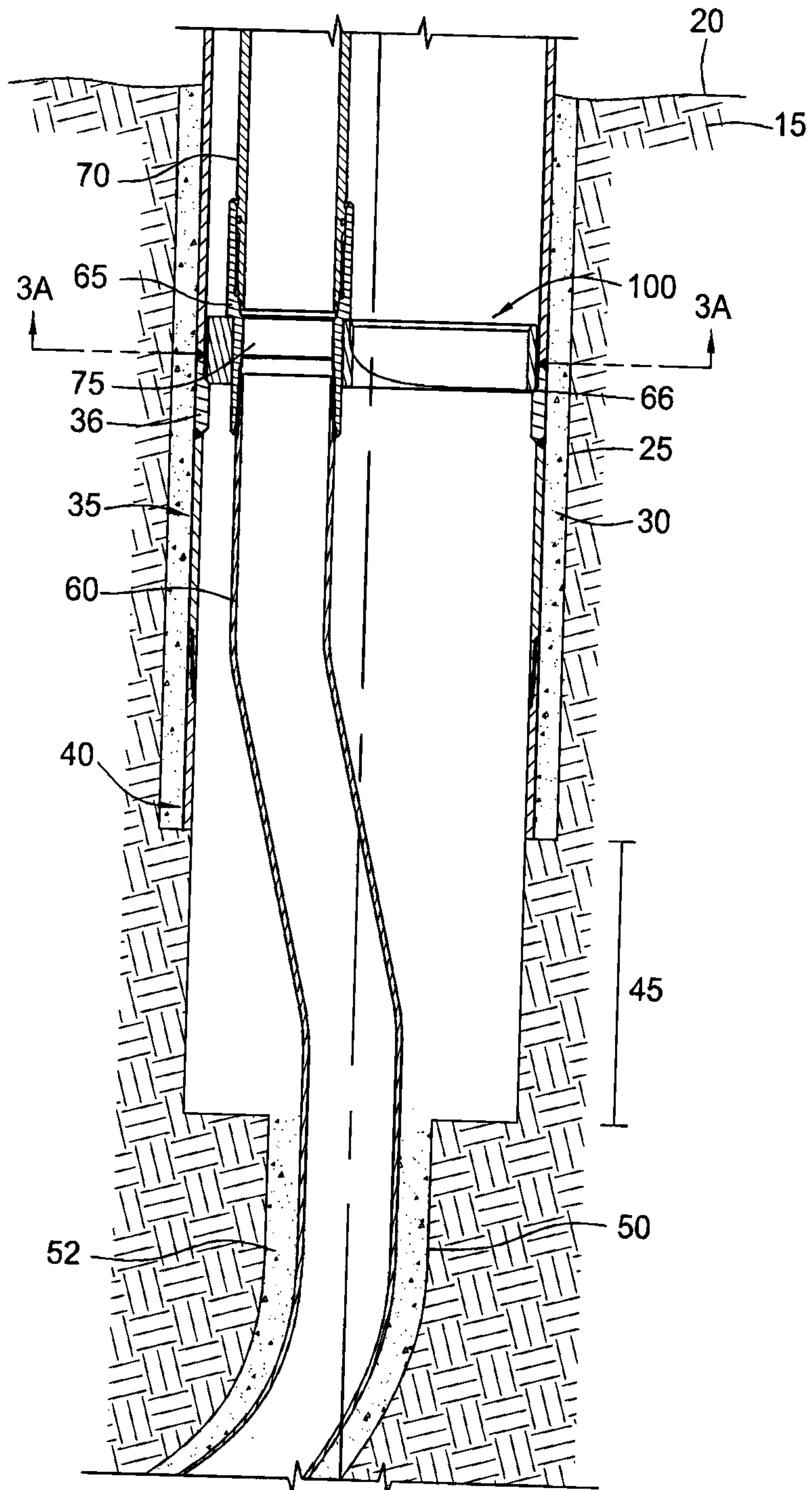

FIG. 3

4/23

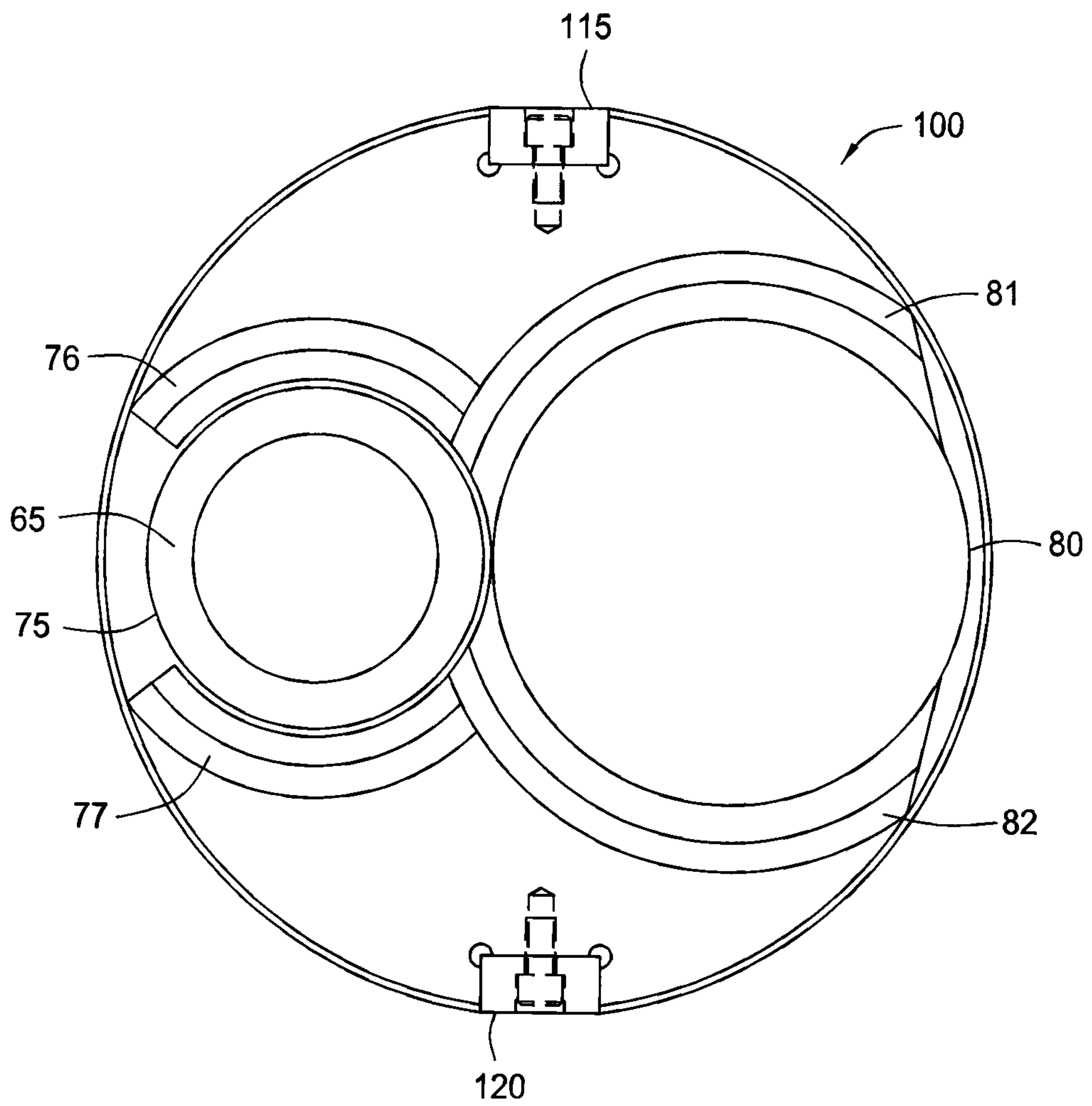

FIG. 3A

5/23

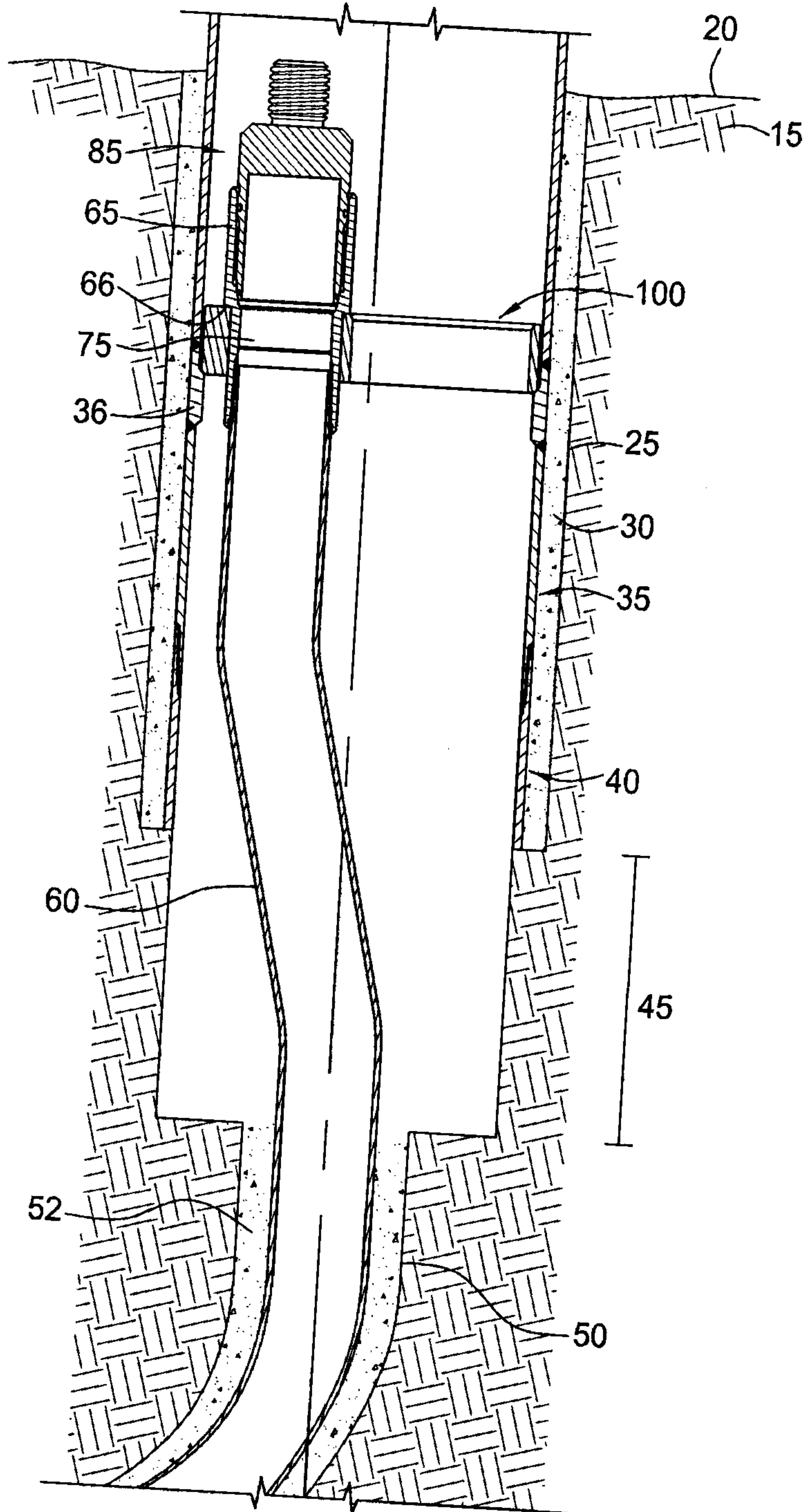

FIG. 4

6/23

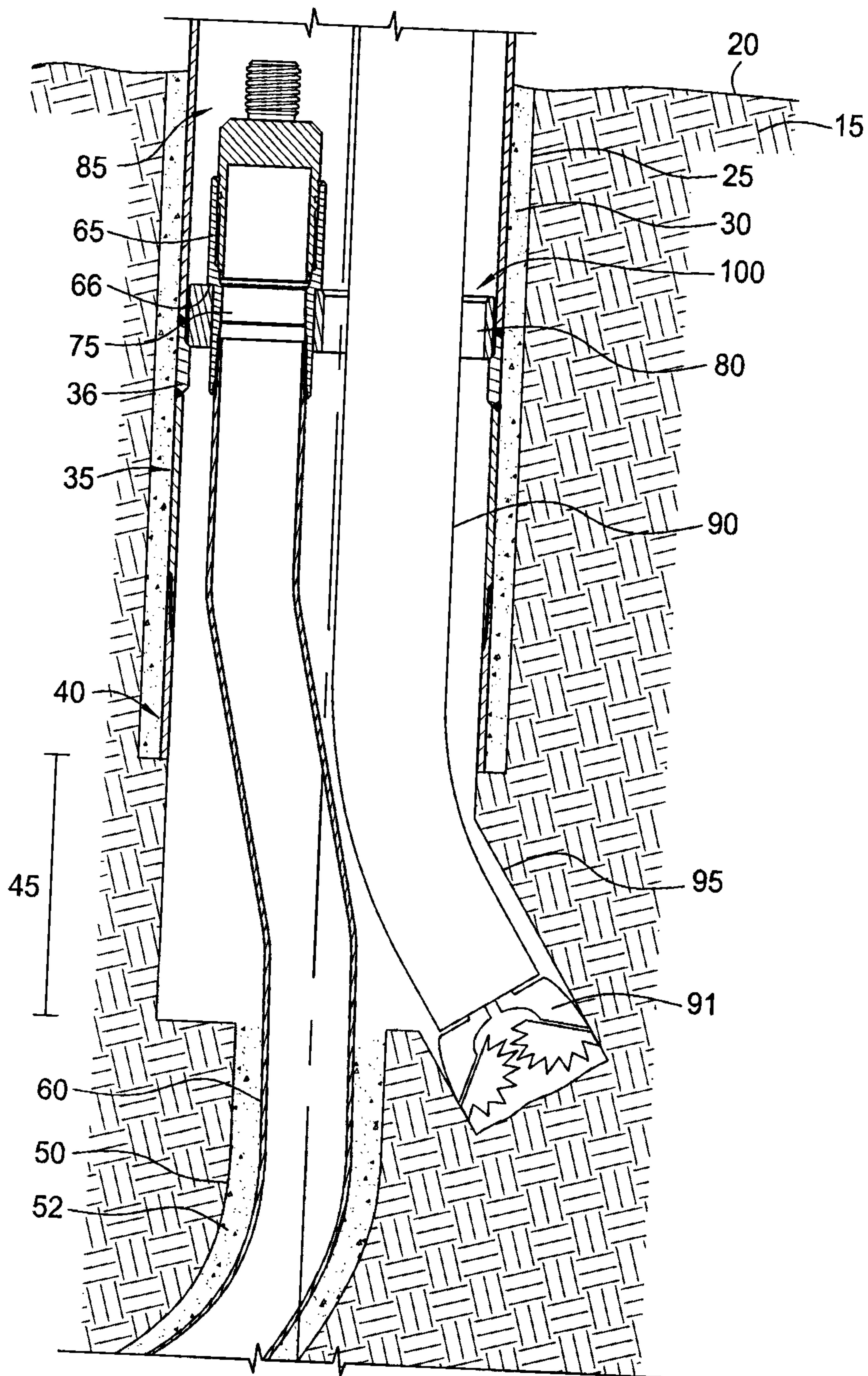

FIG. 5

7/23

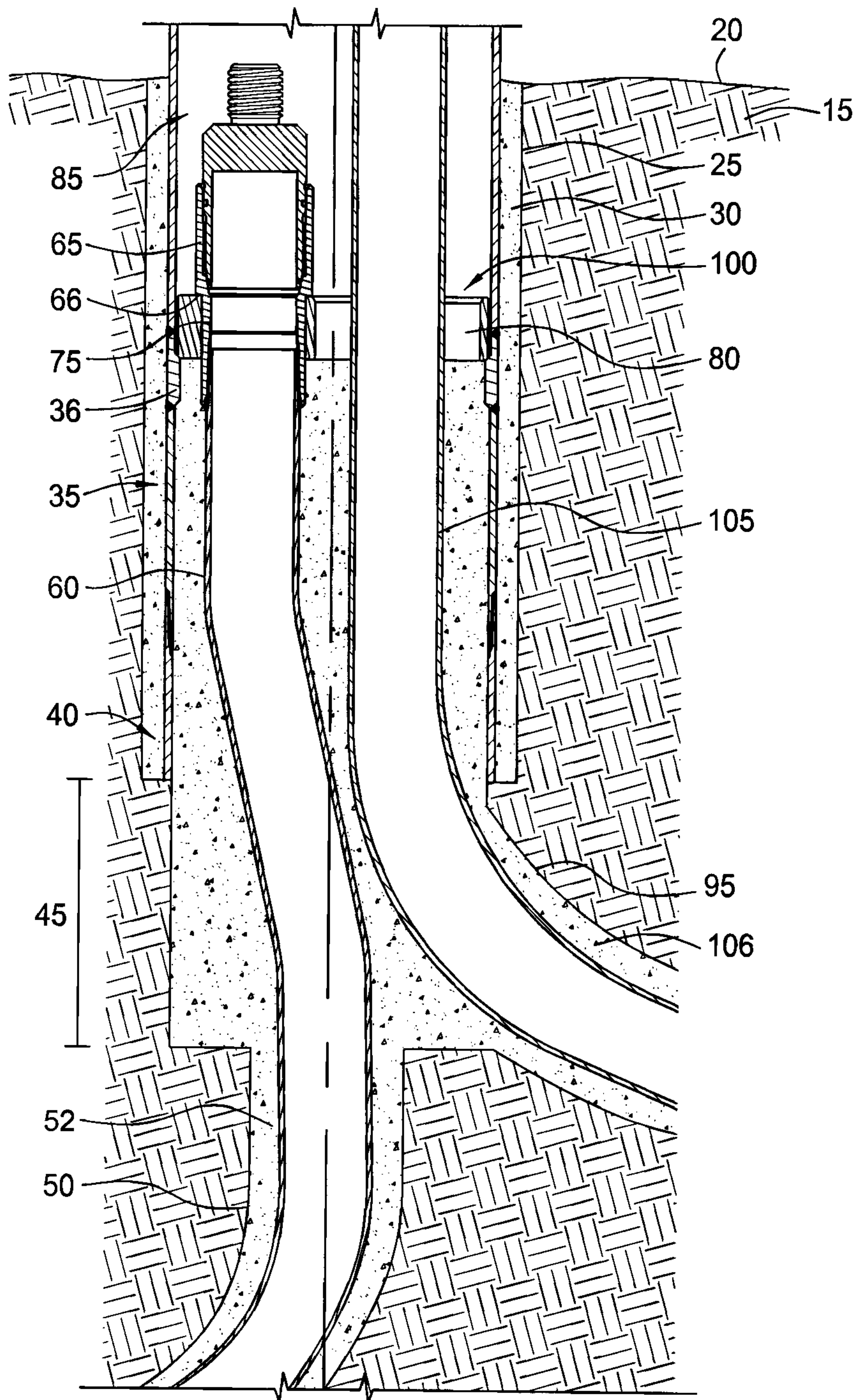

FIG. 6

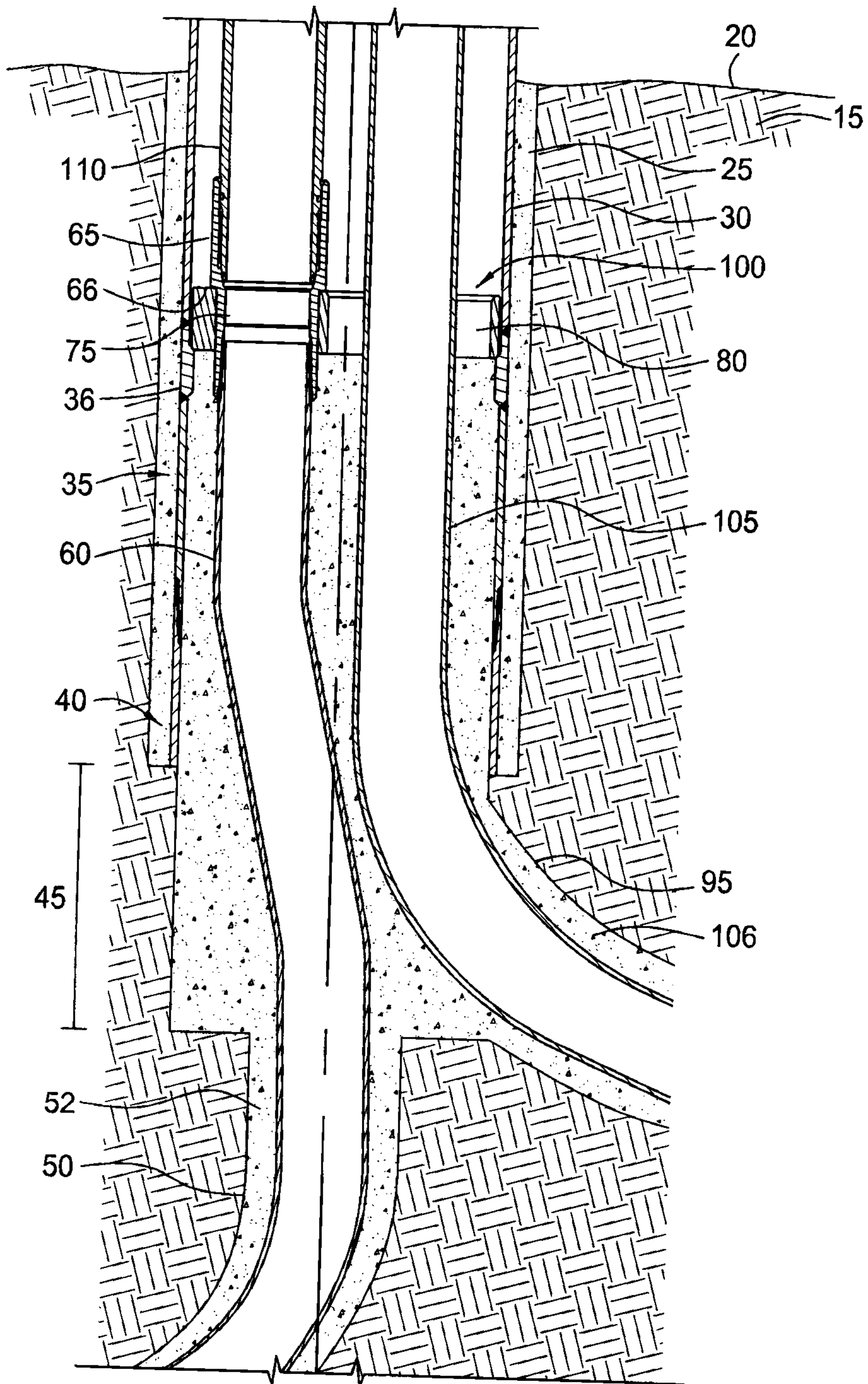

FIG. 7

9/23

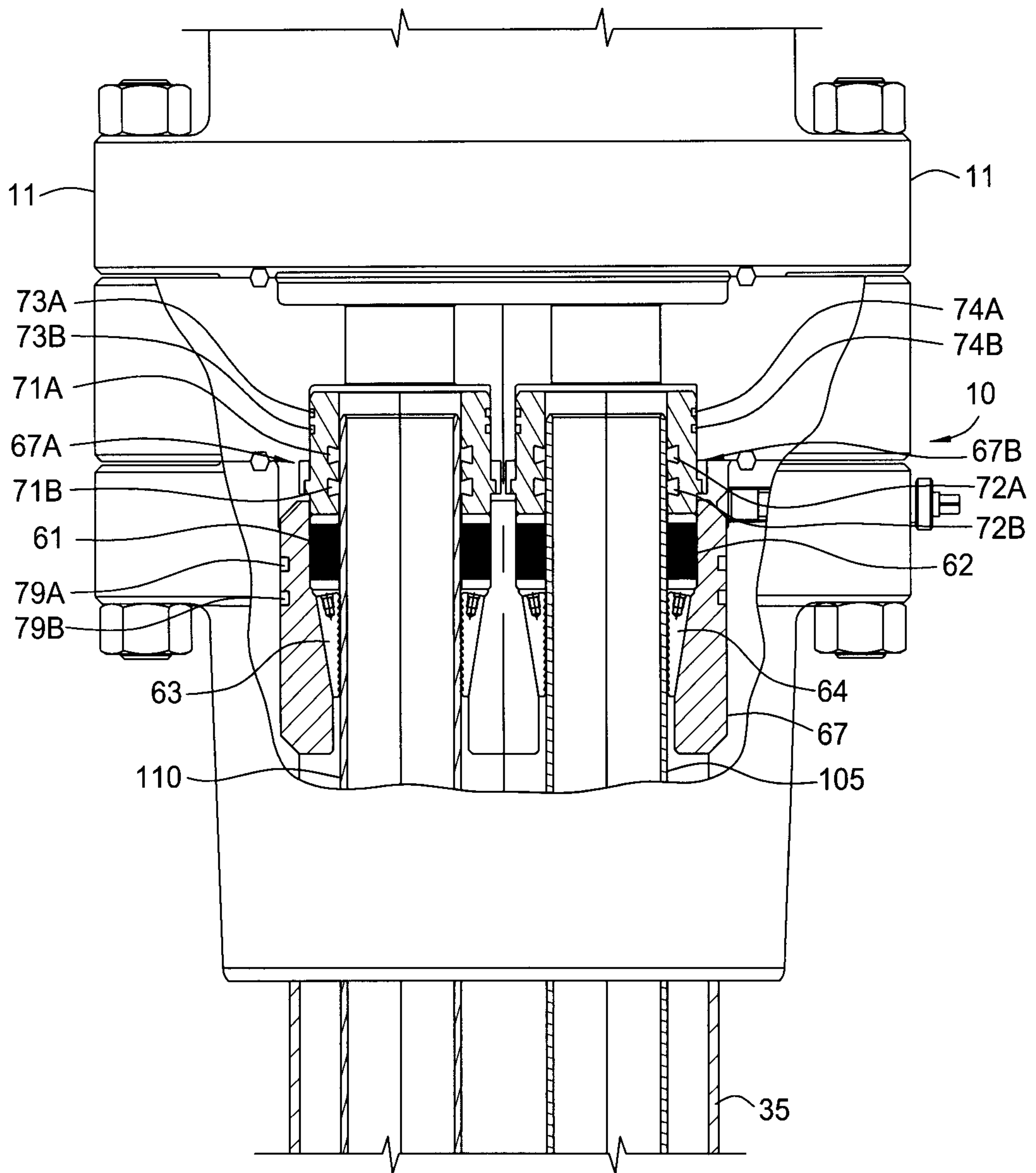

FIG. 8

10/23

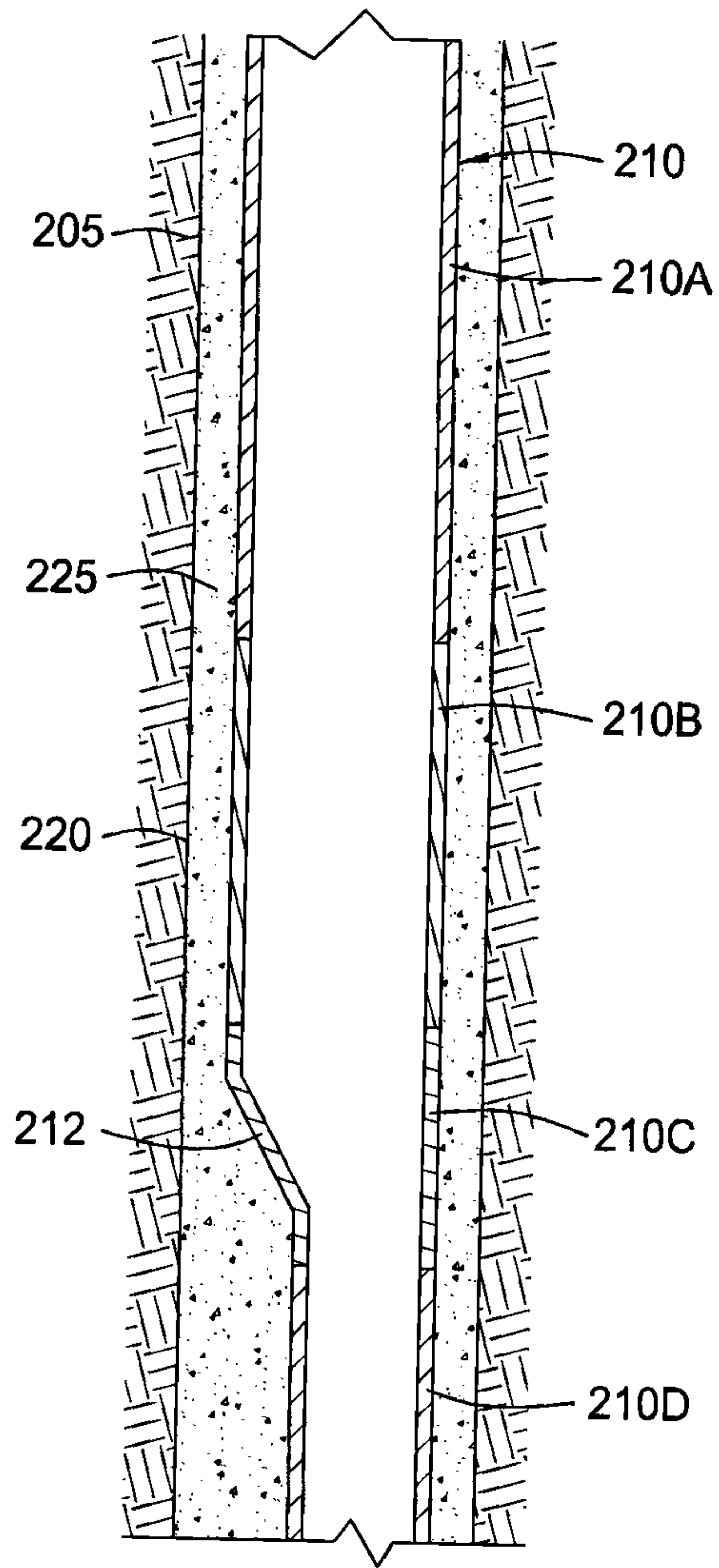

FIG. 9

11/23

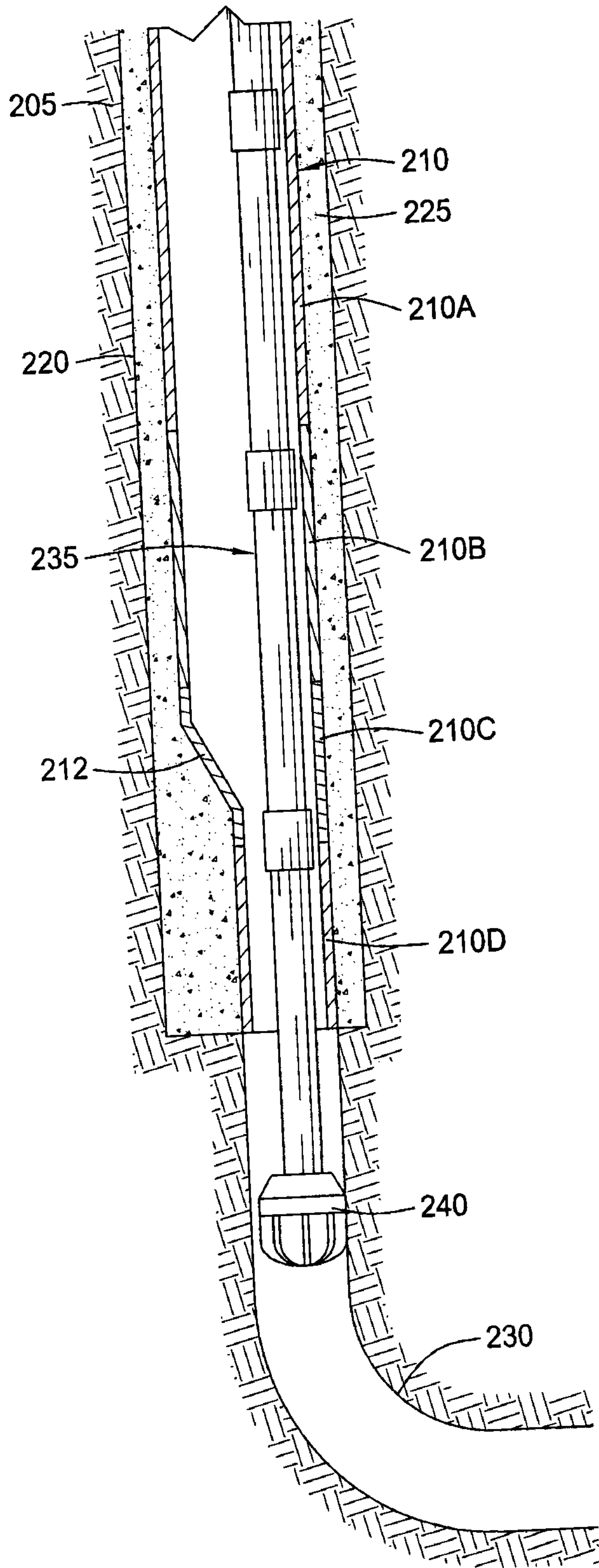

FIG. 10

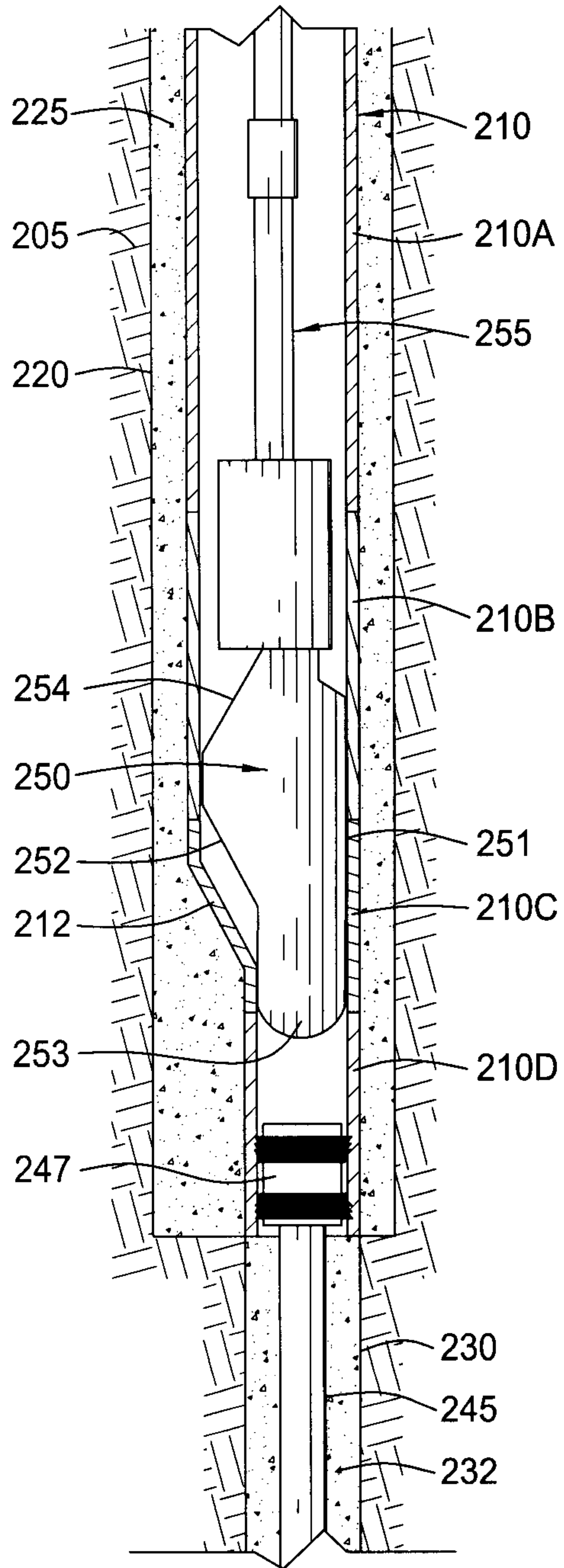

FIG. 11

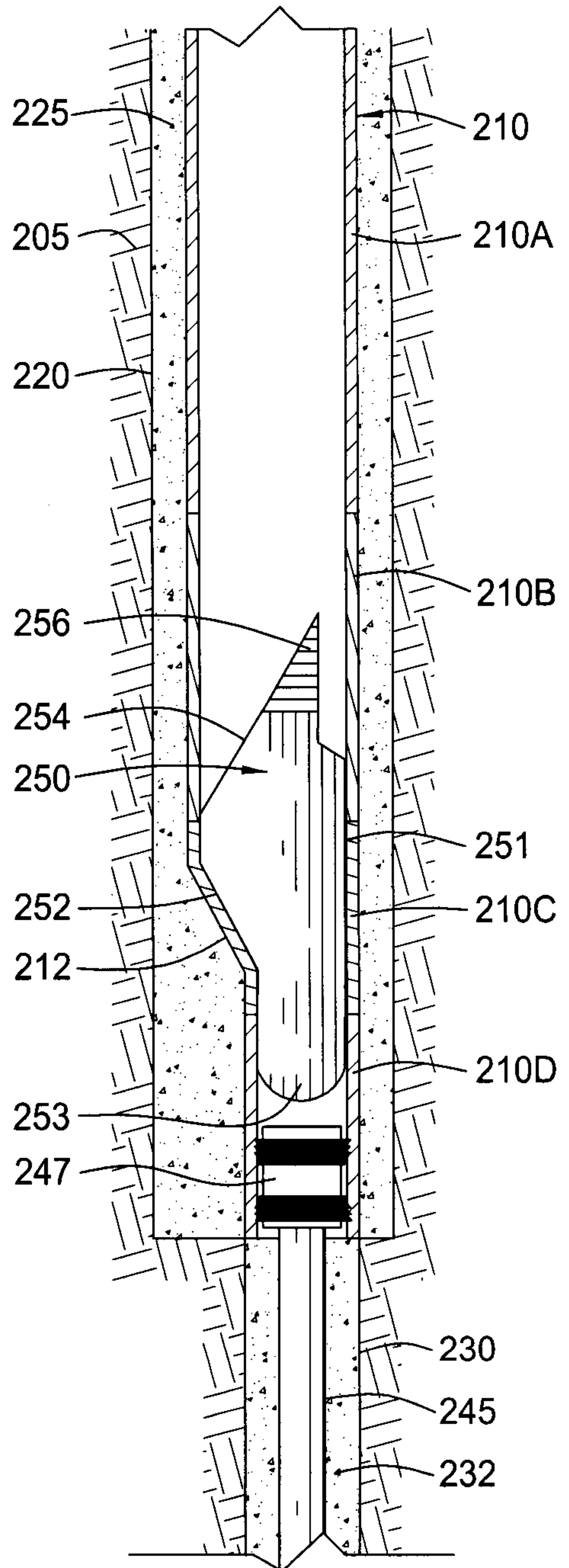

FIG. 12

13/23

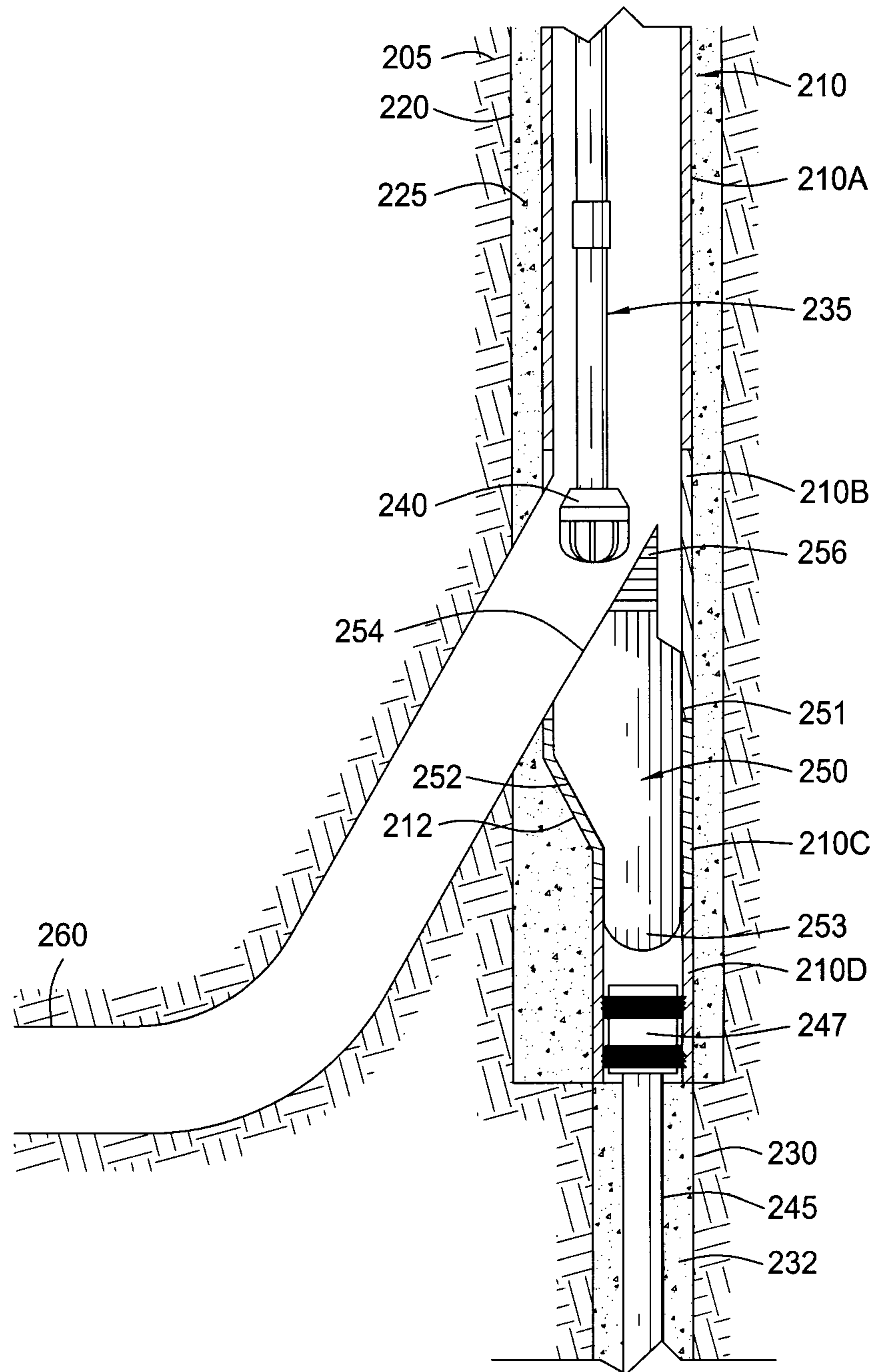
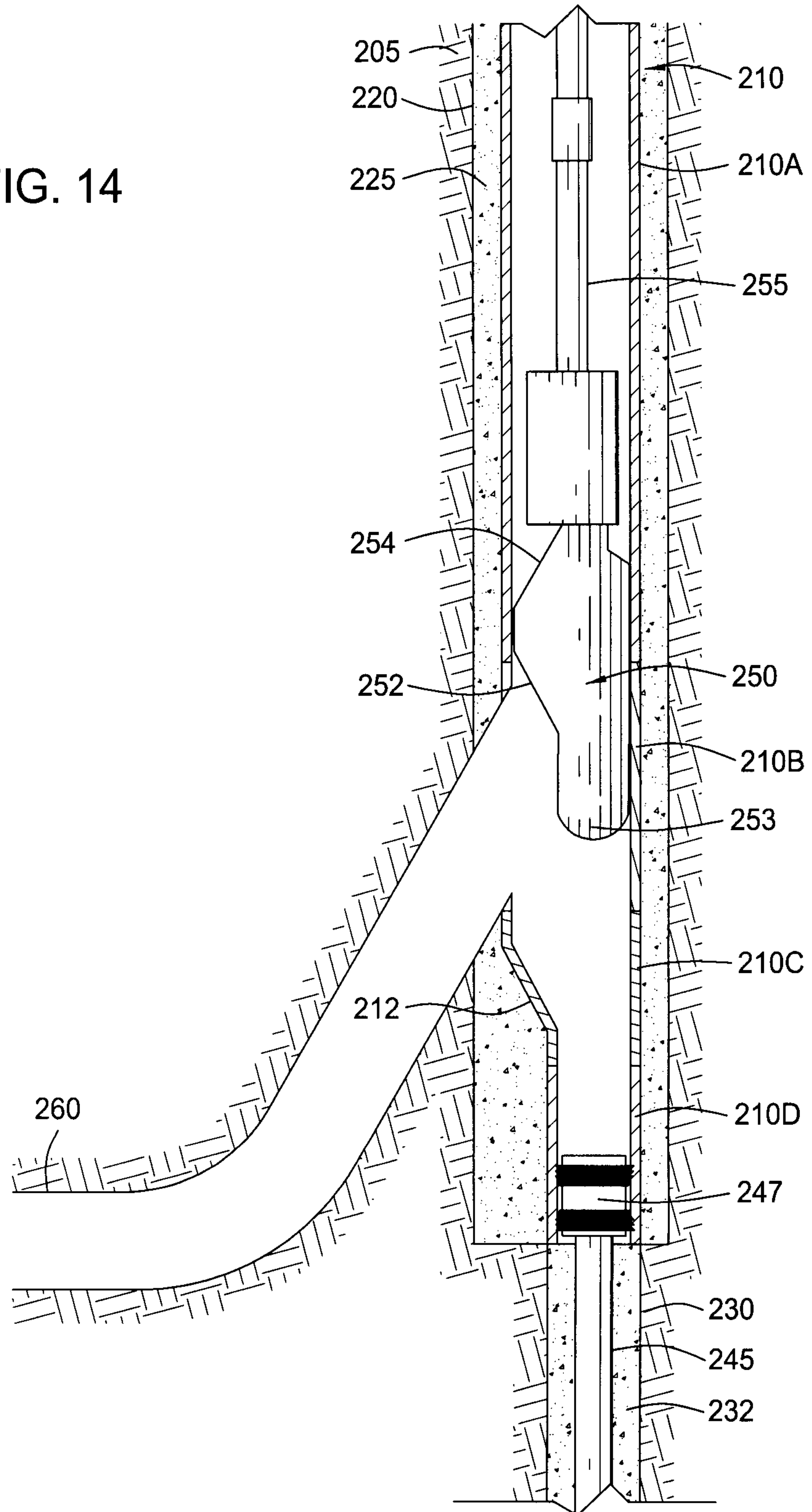

FIG. 13

14/23

FIG. 14



15/23

FIG. 15

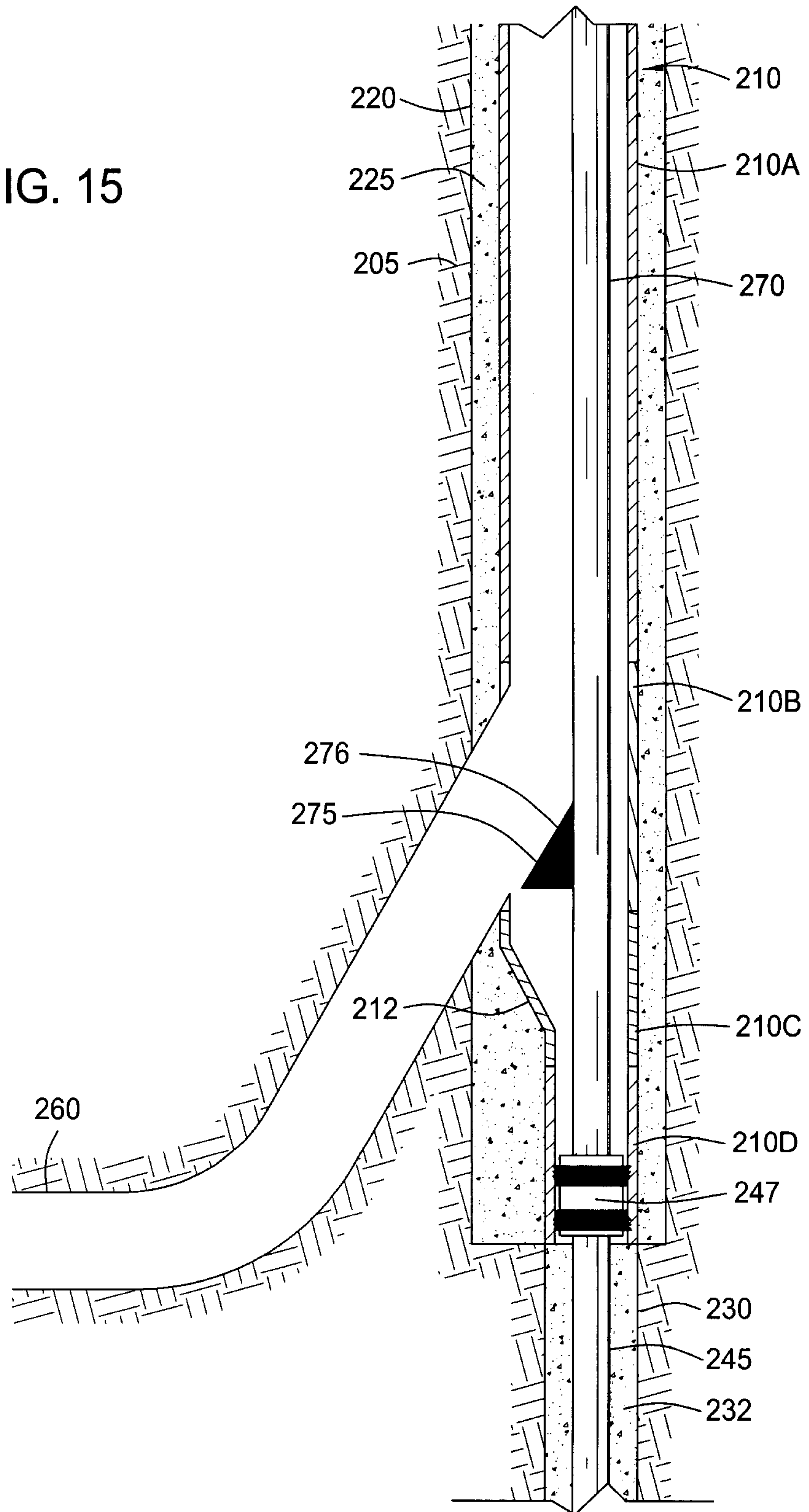

16/23

FIG. 16

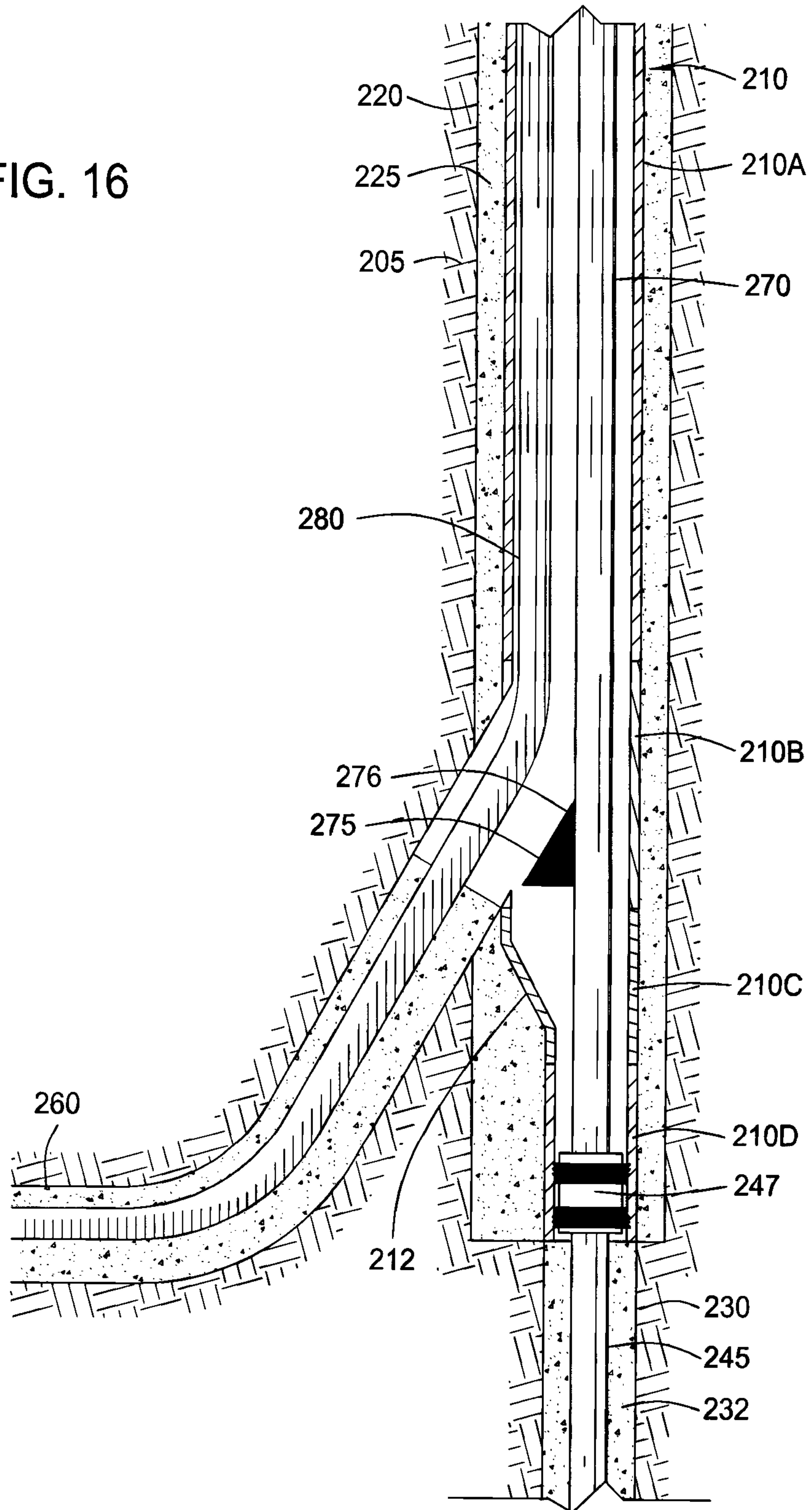

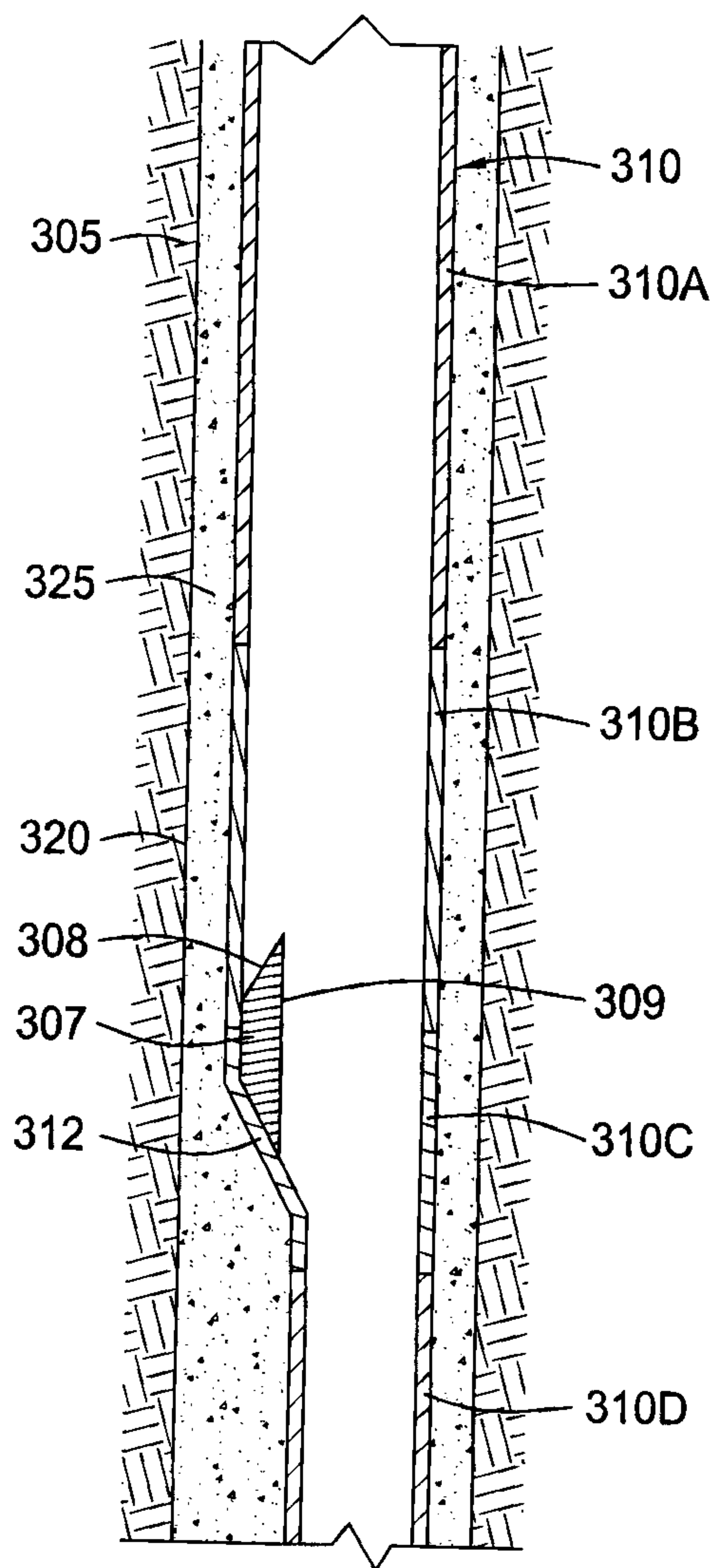

FIG. 17

FIG. 20

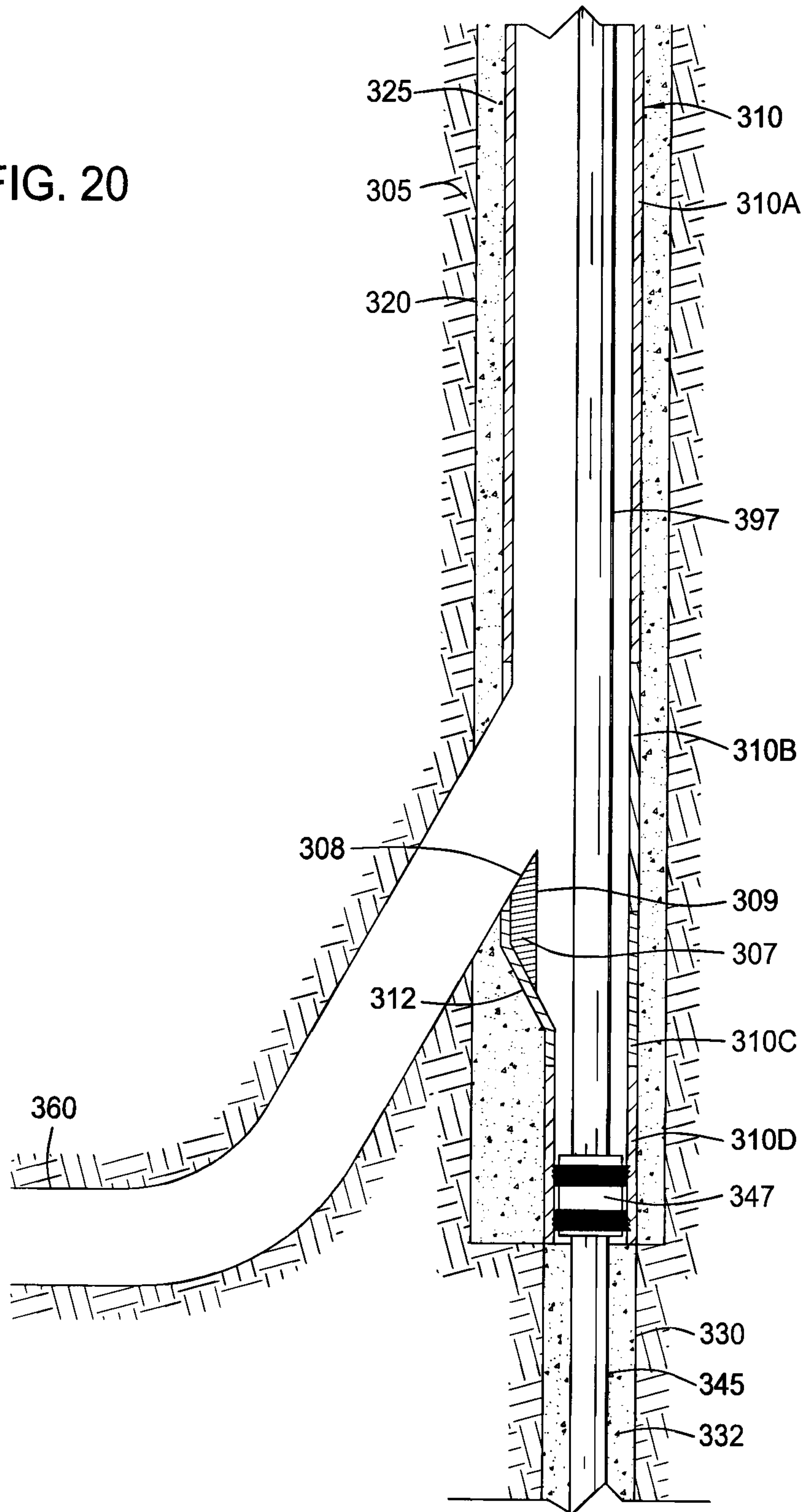
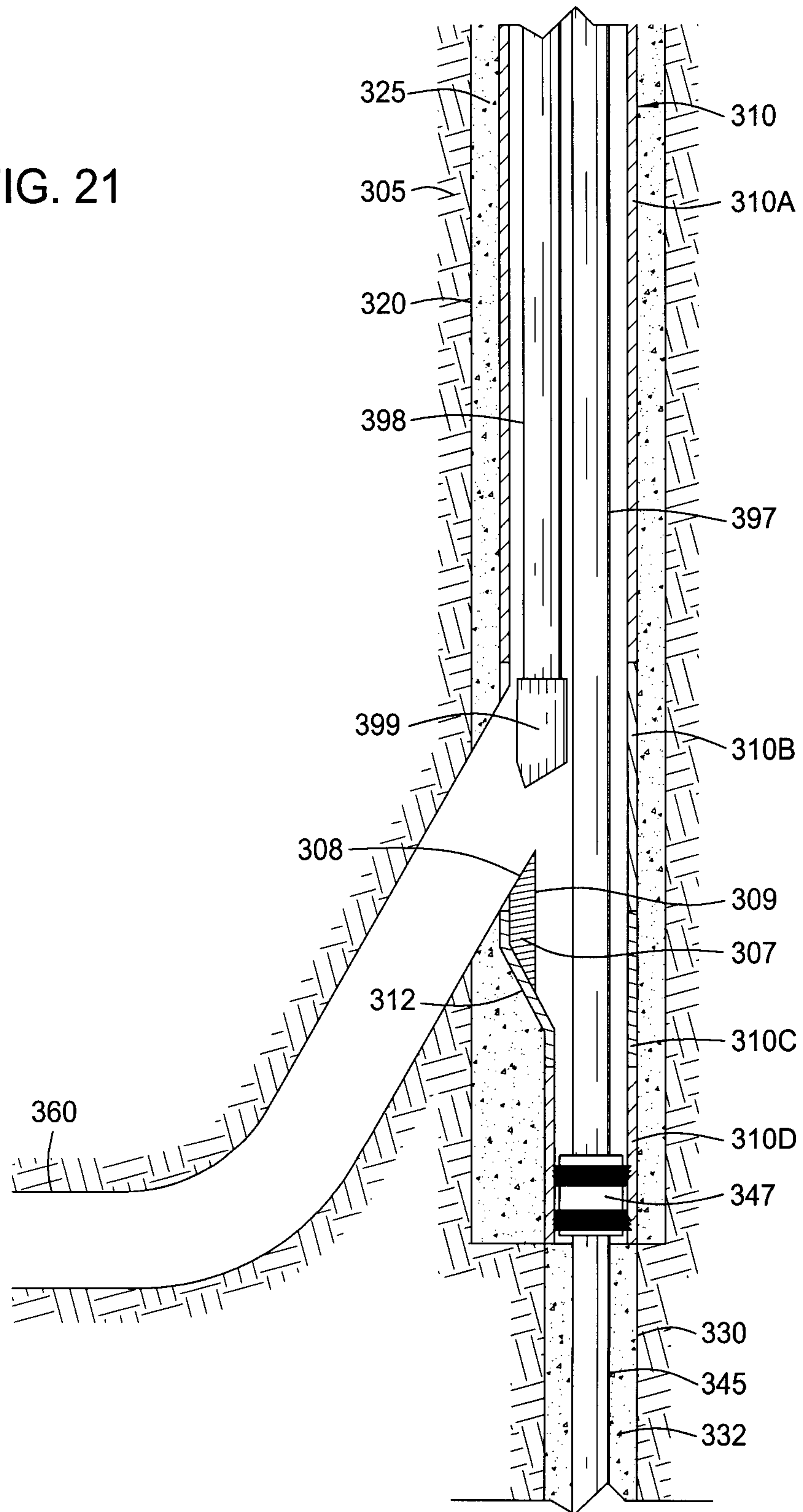

FIG. 21



21/23

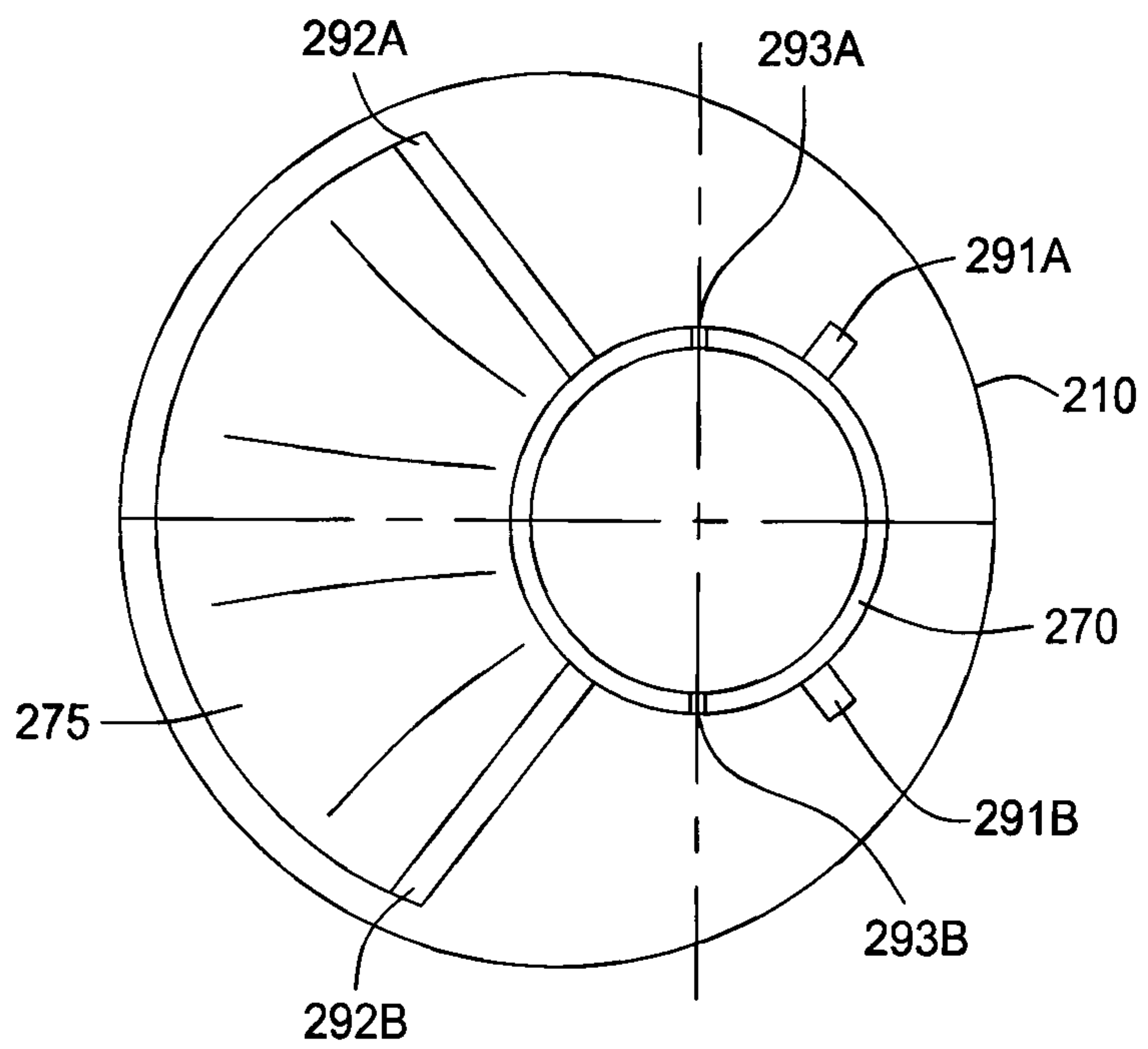

FIG. 22

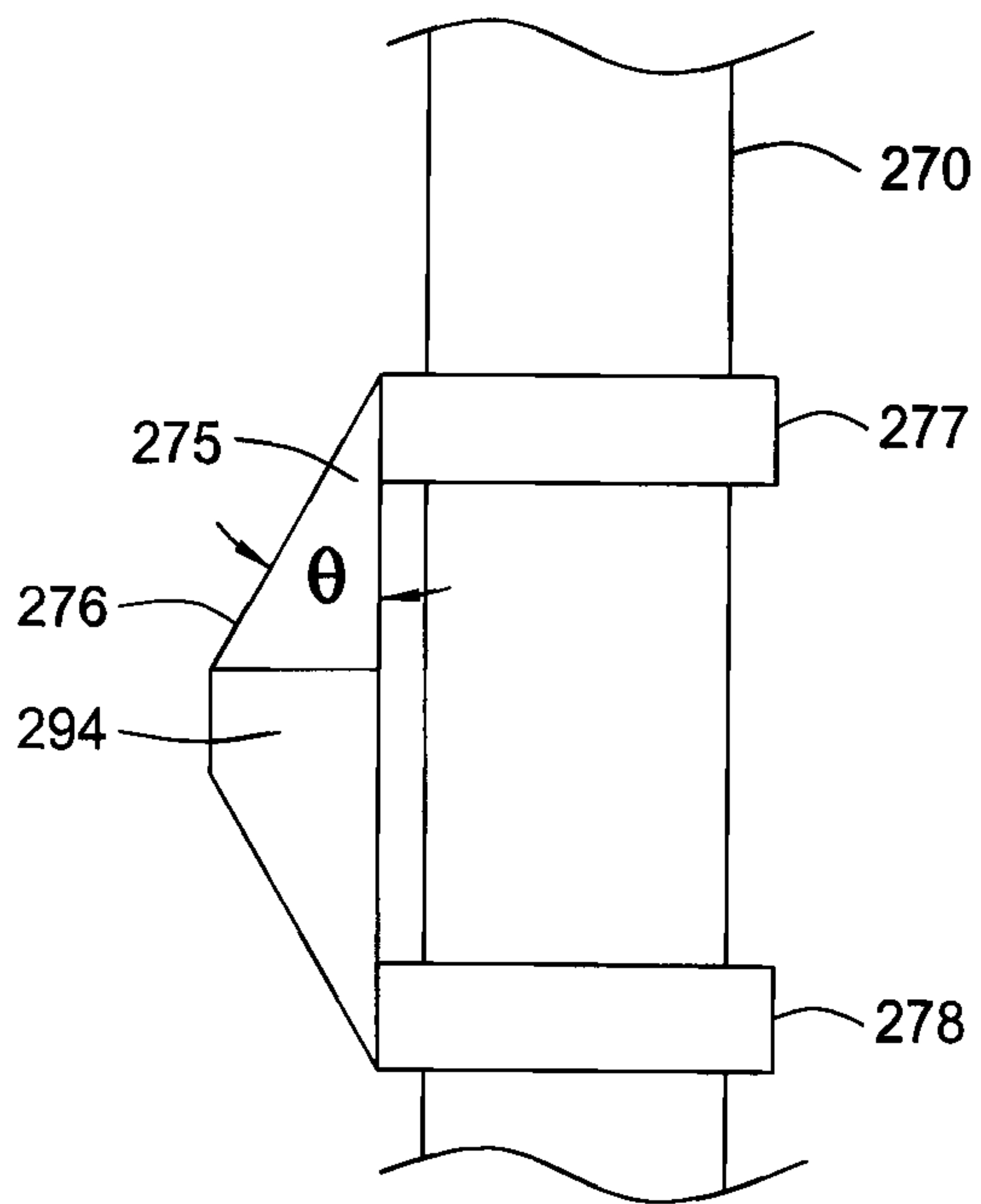

FIG. 23

22/23

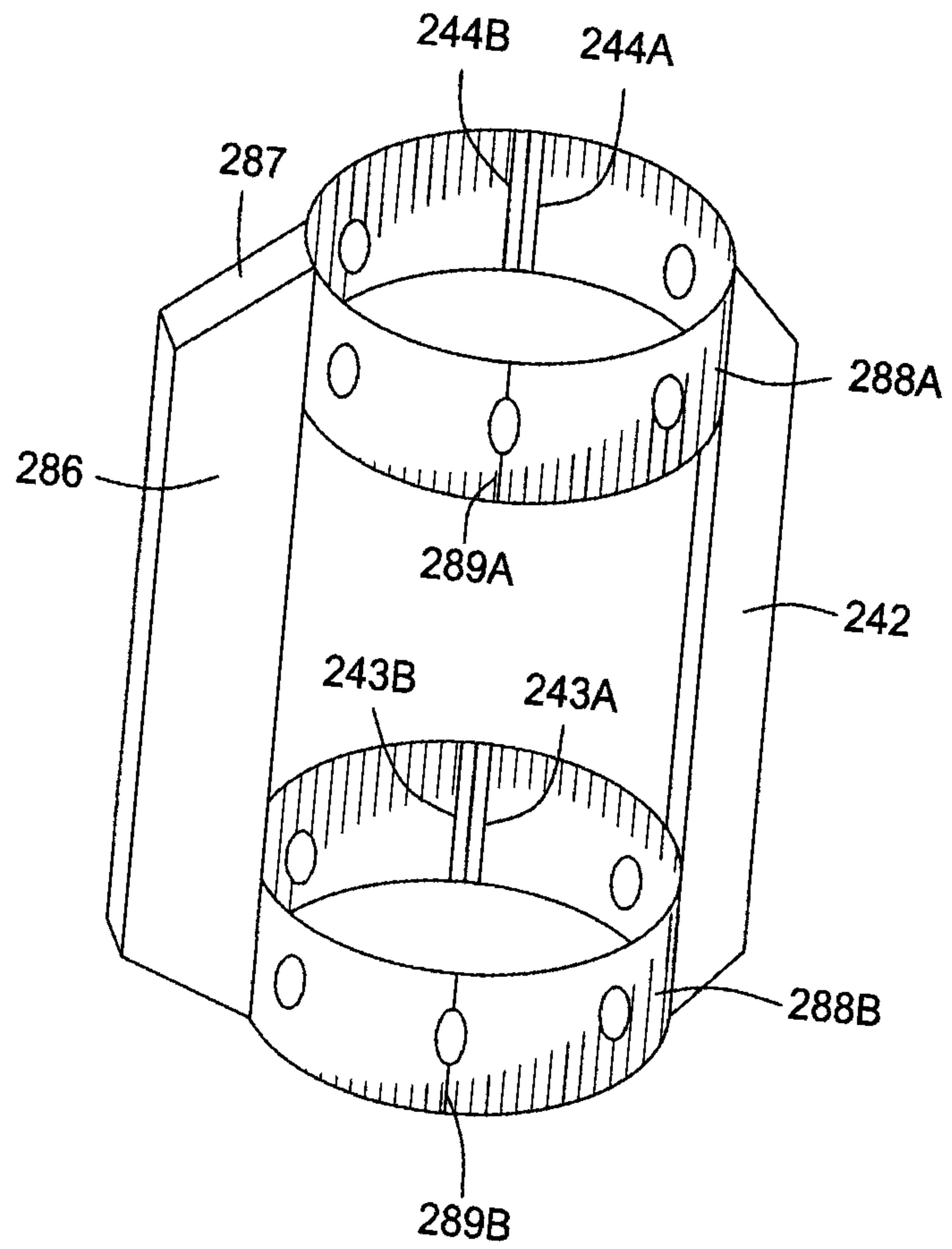

FIG. 24

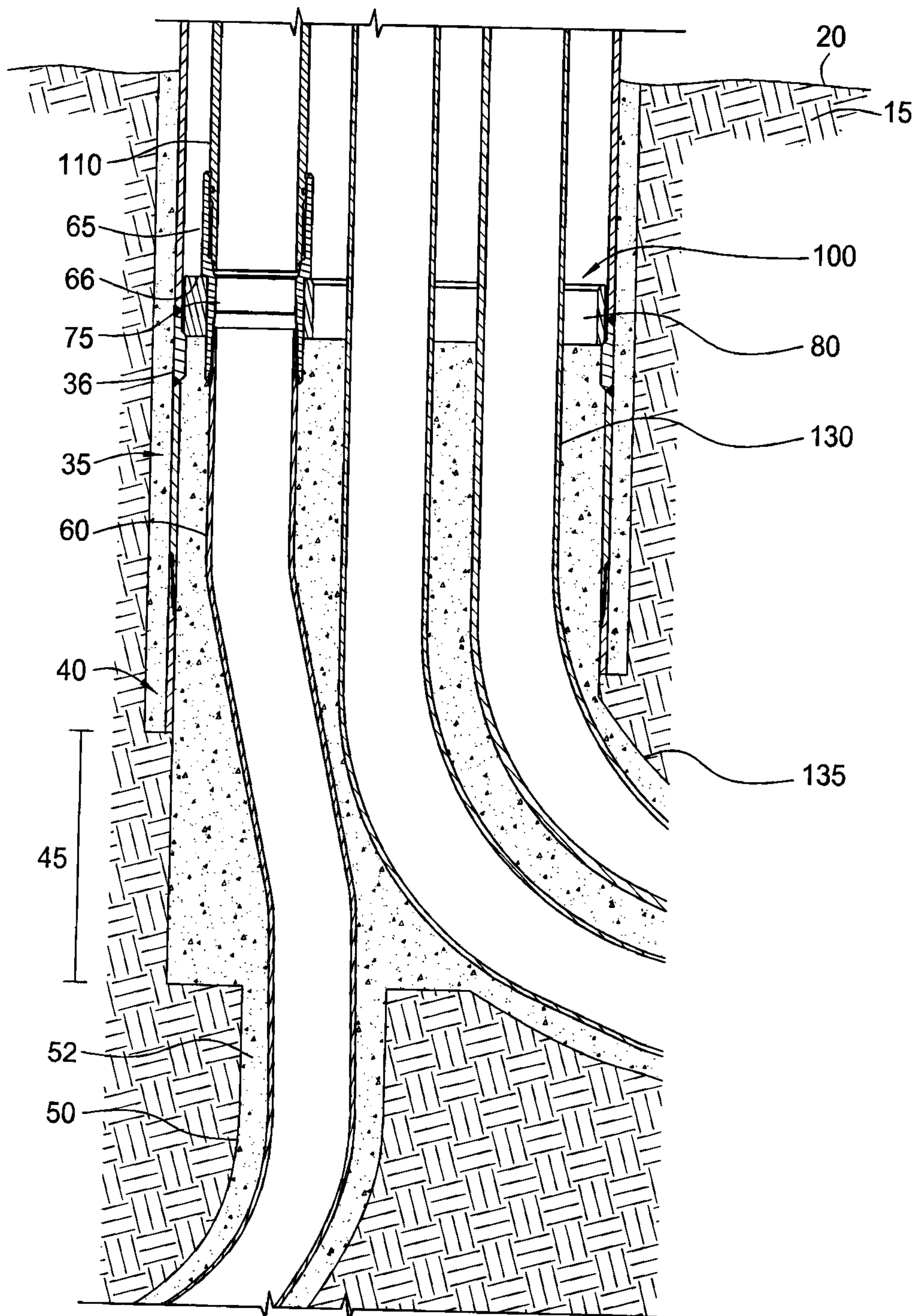

FIG. 25

