

(12) INTERNATIONAL APPLICATION PUBLISHED UNDER THE PATENT COOPERATION TREATY (PCT)

(19) World Intellectual Property Organization
International Bureau



(43) International Publication Date
11 December 2003 (11.12.2003)

PCT

(10) International Publication Number
WO 03/102432 A1

- (51) International Patent Classification⁷: **F16B 39/282**, 39/24, 37/04, 21/18
- (21) International Application Number: PCT/CA03/00769
- (22) International Filing Date: 30 May 2003 (30.05.2003)
- (25) Filing Language: English
- (26) Publication Language: English
- (30) Priority Data:
10/157,895 31 May 2002 (31.05.2002) US
- (63) Related by continuation (CON) or continuation-in-part (CIP) to earlier application:
US 10/157,895 (CIP)
Filed on 31 May 2002 (31.05.2002)
- (71) Applicant (for all designated States except US): **DUO-CAM INC.** [CA/CA]; 2180 Speers Road, Oakville, Ontario L6L 2X6 (CA).
- (72) Inventor; and
- (75) Inventor/Applicant (for US only): **HEWGILL, John** [US/US]; 45 Mariner Street, Buffalo, NY 14201 (US).
- (74) Agent: **ORANGE, John, R., S.**; McCarthy Tetrault LLP, Suite 4700, Box 48, 66 Wellington Street West, Toronto, Ontario M5K 1E6 (CA).
- (81) Designated States (national): AE, AG, AL, AM, AT, AU, AZ, BA, BB, BG, BR, BY, BZ, CA, CH, CN, CO, CR, CU, CZ, DE, DK, DM, DZ, EC, EE, ES, FI, GB, GD, GE, GH, GM, HR, HU, ID, IL, IN, IS, JP, KE, KG, KP, KR, KZ, LC, LK, LR, LS, LT, LU, LV, MA, MD, MG, MK, MN, MW, MX, MZ, NI, NO, NZ, OM, PH, PL, PT, RO, RU, SC, SD, SE, SG, SK, SL, TJ, TM, TN, TR, TT, TZ, UA, UG, US, UZ, VC, VN, YU, ZA, ZM, ZW.
- (84) Designated States (regional): ARIPO patent (GH, GM, KE, LS, MW, MZ, SD, SL, SZ, TZ, UG, ZM, ZW), Eurasian patent (AM, AZ, BY, KG, KZ, MD, RU, TJ, TM), European patent (AT, BE, BG, CH, CY, CZ, DE, DK, EE, ES, FI, FR, GB, GR, HU, IE, IT, LU, MC, NL, PT, RO, SE, SI, SK, TR), OAPI patent (BF, BJ, CF, CG, CI, CM, GA, GN, GQ, GW, ML, MR, NE, SN, TD, TG).
- Published:**
— with international search report
- For two-letter codes and other abbreviations, refer to the "Guidance Notes on Codes and Abbreviations" appearing at the beginning of each regular issue of the PCT Gazette.

(54) Title: FASTENER

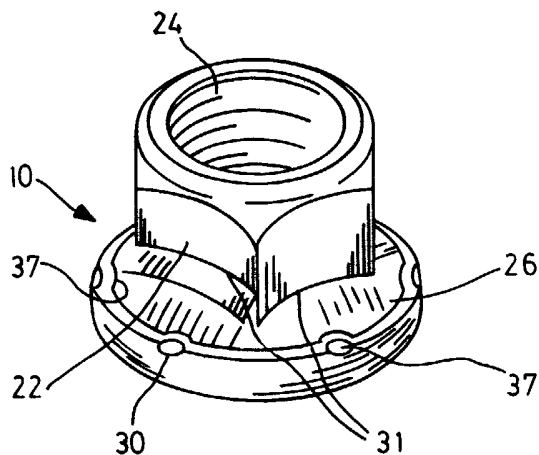

(57) Abstract: A fastener has a body (20) and a cage (30) with cam surfaces formed on interengaging components to inhibit relative rotation. A washer (36) is interposed between said surfaces and has oppositely directed faces with a cam surfaces formed on one face and serrations on the other. The serrations engage the planar underside of the body.



WO 03/102432 A1

FASTENER

[0001] This application is a continuation-in-part of United States Application No. 10/157,895 filed May 31, 2002 which is a continuation in part of US Application No. 09/431,977 filed October 29, 1999 which is a continuation-in-part of United States Application No. 09/183,640 filed October 30, 1998 the contents of which are incorporated herein by reference.

[0002] The present invention relates to fasteners.

[0003] It is well known to use threaded fasteners to secure components to one another. It is also well known to inhibit separation of the fasteners by providing a vibration resistant washer between the fastener and the component. Typically this would take the form of a spring washer inserted between a face of a nut and a component being clamped.

[0004] An alternative form of fastener is shown in U.S. Patent 5,626,449 to Hong Kong Disc Lock Company. In this type of fastener a washer is inserted between the nut and the component and opposed faces of the nut and washer are provided with cam surfaces. The cam surfaces effect axial movement between the washer and the nut upon relative rotation. By arranging for the cam surfaces to have an angle greater than the helix angle of the thread of the nut, unintentional removal of the nut is avoided.

[0005] An arrangement shown in U.S. Patent 5,203,656 utilizes a pair of cam surfaces by the provision of an intermediate member between a lower washer and a nut. This is referred to as a three-piece arrangement. However, a disadvantage of the arrangement shown in '656 patent is that a central pilot is used to retain the intermediate component on the nut. The pilot is swaged in situ which leads not only to expensive manufacture but also requires close control of the tolerances to ensure the necessary rotational and axial clearances are provided.

1 [0006] U.S. Patent 5,688,091 to McKinlay discloses a similar type of fastener to that of
2 5,626,449 in which a cage is used to retain a washer beneath the flared head of a nut. In this
3 arrangement however a cam is provided between the nut and washer. The face between the
4 washer and the cage is planar to provide a single pair of cam surfaces between the washer and
5 nut. The adjacent planar surfaces between the washer and cage allow the washer to rotate as it is
6 tightened. However, it has been found that this arrangement will rotate due to vibration to undo
7 the fastener in the majority of applications.

8
9 [0007] In PCT application CA99/00985, a number of arrangements of fasteners are
10 shown that offer enhanced performance over these prior fasteners. Whilst excellent performance
11 has been demonstrated with such fasteners, it is found that in applications where there is the
12 possibility of repeated use, the cam faces formed on the underside of the body of the nut may not
13 withstand repeated tightening. Industry standards require the nut body to be relatively soft and
14 the hardened cams on the engaging washer tend to damage the cams on the nut with repeated
15 use.

16
17 [0008] It is an object of the present invention to obviate or mitigate the above
18 disadvantages.

19
20 [0009] In general terms the present invention provides a fastener which has a body with
21 an end face and a cage rotatably secured to the body with a planar face directed toward the end
22 face. The sidewalls of the cage extend toward and over the lower portion of the body to permit
23 rotation but inhibit axial separation. A pair of washers is interposed between the body and the
24 cage and has a pair of oppositely directed faces to overlie respective faces on the body and cage.
25 Opposed pairs of faces are provided with complimentary cam surfaces so that relative rotation
26 between the components of the fastener cause axial displacement of the components.

27
28 [0010] Embodiments of the invention will now be described by way of example only
29 with reference to the accompanying drawings in which: -

- 1
- 2 [0011] Figure 1 is a perspective view of a fastener.
- 3 [0012] Figure 2 is a section through a fastener installed between a pair of components.
- 4 [0013] Figure 3 is an enlarged view of a portion of the fastener shown in Figure 1.
- 5 [0014] Figure 4 is a view on the line IV - IV of Figure 3.
- 6 [0015] Figure 5 is a plan view on the line V-V of Figure 3.
- 7 [0016] Figure 6 is an exploded view of the components in an alternative embodiment of
8 fastener.
- 9 [0017] Figure 7 is a view on an enlarged scale on the line VI-VI of figure 6,
- 10 [0018] Figure 8 is a section of a further embodiment fastener.
- 11 [0019] Figure 9 is a plan view of Figure 8 with portions thereof sectioned for clarity.
- 12 [0020] Figure 10 is a section through a tool used to form the embodiment of Figure 9.
- 13
- 14 [0021] In reference to Figures 1 and 2, a fastener generally indicated 10 includes a bolt
15 12 having a head 14. The bolt 12 includes a threaded shank 16 on which is threaded a nut
16 assembly 18.
- 17
- 18 [0022] The nut assembly includes a body of 20 having planar flats 22, typically arranged
19 as sides of a hexagon, and an internal bore 24 having a thread form corresponding to the shank
20 16.
- 21
- 22 [0023] The lower end of the body 20 is flared to provide a skirt 26 with a generally
23 planar end face 28. Upper surface 29 of skirt 26 intersects the flats 22 at a raduissed fillet 31
24 whose height alternates between high and low from flat to flat.
- 25
- 26 [0024] A cage 30 is positioned adjacent the end face 28 and has a bottom wall 32. The
27 bottom wall 32 has an inwardly directed face 33 spaced from the end face 28. A central aperture
28 35 is provided to receive the bolt 12. A peripheral sidewall 34 extends axially toward and beyond
29 the flared skirt 26.

1

2 **[0025]** The cage 30 is heat treated to provide two zones of different physical
3 characteristics with the bottom wall 32 relatively hard and the sidewall 34 more ductile. The
4 upper extremity of the sidewall 34 is locally deformed radially inward to overlie the sloped upper
5 surface of the skirt 26 and limit relative axial movement between the cage 30 and the body 20.
6 The local deformation which is facilitated by the ductility of the sidewall, is provided at six
7 uniformly spaced locations indicated at 37 that provide circumferential abutments as well as
8 radial retention between the cage 30 and body 20.

9

10 **[0026]** A pair of washers 36, 37 are interposed between the cage 30 and body 20. Each
11 of the washers 36, 37 has a pair of oppositely directed end faces, 38, 40 and 39, 41 respectively.
12 As can best be seen in Figure 3, the opposed faces 38, 41 of the washers 36, 37 respectively are
13 formed with complimentary cam surfaces 42, 42'. The cam surfaces 42, 42' each includes a
14 series of planar facets 46 inclined to a radial plane and uniformly distributed about the
15 longitudinal axis of the bolt 12. The facets 46 are parallel to one another to provide full face
16 contact. The facets 46 are interconnected by a generally axially extending risers 48 to provide
17 pairs of opposed toothed surfaces that are parallel to one another. The inclination of the facets
18 46 is selected to be greater than the helix angle of the thread form 24 so that the axial movement
19 induced by cooperation of the surfaces for a given rotation of the body relative to the fastener is
20 greater than the axial displacement of the body 20 relative to the shank 16. The aggregate height
21 of the risers 48 for each set of cam surfaces 42, 42' is typically the 1.5 times pitch of the thread
22 to achieve satisfactory locking. The height of each risers 48 is determined by dividing the
23 aggregate height by the number of facets. The number of facets is selected to be an integral
24 multiple of the number of flats and, for the cam surfaces 42, 42' 12 facets is found satisfactory.
25 The height of the risers 48 will then be 1.5 times the pitch divided by 12.

26

27 **[0027]** Complementary cam surfaces 44, 44¹ are formed on opposed faces 40, 33 of the
28 washer 36 and bottom wall 32, respectively. The cam faces, 44, 44' also includes a series of
29 parallel planar facets 50 similar to facets 46 of cam surface 42 but oppositely directed with

1 respect to facets 46. The number of facets 50 is greater than the facets 46, but the aggregate
2 height of risers 52 that interconnect the facets 50 is similar. Accordingly, the height of each of
3 the risers 52 is less than that of risers 48. The cam surfaces 42, 42' are therefore relatively
4 coarse and the cam surfaces 44, 44' relatively fine. Cam surfaces 44 will cooperate when subject
5 to vibration to inhibit relative rotation between the cage 30 and washer 36. This allows the cams
6 42 to cooperate and prevent loosening of the nut 17.

7
8 **[0028]** In a typical embodiment, the 360° circle of coarse and fine cams will each have a
9 total number divisible by the wrenching flats of the nut. For a hexagonal nut therefore, the
10 coarse cam circle will typically consist of twelve cams, for diameters from ½ to 1-½ inches
11 inclusive and the fine cam circle will consist of 18 cams.

12
13 **[0029]** The radial extent of the cams measured from the inner edge of the bore will range
14 from 5 mm to 8 mm depending on the bolt diameter.

15
16 **[0030]** The face 39 of washer 37 is formed with a series of fine serrations, 55 extending
17 radially and disposed uniformly around the circumference of the face 39. The serrations 55 have
18 inclined surfaces 56 that are angled at approximately 15° with respect to the radial plane of the
19 washer 37 and terminate in axial faces having an axial length in order of 0.20 mm to 0.25 mm.
20 In a typical washer used with a M20 nut (20 mm nominal bolt diameter) the washer 37 will have
21 a diameter of 38 mm and there will be 84 serrations extending about the face 39. For a M22 nut,
22 the number of serrations is increased of 90. It is found that the depth of the serrations is not as
23 critical as the included angle between the inclined and axial faces 56, 57 where the 15° shape
24 provided the requisite sharpness at the extremity of the serrations. The serrations 55 are directed
25 oppositely to the facets 46 (i.e. the axial faces 57 face the same directions as the risers 48 when
26 on oppositely directed faces) and engage the planer undersurface 28 of the body 20 and inhibit
27 rotation between the washer 37 and body 20 in one direction. The body 20 typically has a
28 hardness between 28 and 36 Rockwell C and the washers 36, 37 have a hardness of between 45

1 and 48. The serrations 55 are thus able to penetrate the under surface 28 upon axial loads being
2 imposed.

3
4 **[0031]** The nut assembly 18 is preassembled by inserting the washers 36, 37 into the cage
5 30 and the body 20 placed on the washer 37. The sidewalls 34 are then radially displaced to
6 overlap the upper surface 29 of flared skirt 26. The ductility of the sidewalls facilitates the
7 displacement while permitting lower face to retain the hardened bearing surface. Preferably, the
8 number of locations where the sidewalls are radially displaced will be similar to the number of
9 wrenching flats on the nut although this may be varied to be either greater or lesser depending on
10 circumstances. Limited axial displacement is provided between the cage 30 and the body 20
11 allowing the cage 30 to rotate relative to body 20. It has been found that the greater height and
12 added hoop strength available at the nut flange provides 30% more strength than a standard nut.

13
14 **[0032]** To fasten a pair of components indicated (A) and (B) in Figure 2, the bolt 12 is
15 passed through an aligned aperture in the two components and the nut assembly 18 threaded onto
16 the shank 16. As the lower face of the cage 30 engages the upper surface of component (A), the
17 cam surfaces 42, 42' and 44, 44' are brought into engagement and the serrations 55 engage the
18 underside 28 of the body 20. The washers 36, cage 30 and body 20 are rotated conjointly. The
19 risers 48 provide torque transmission between the washers 36, 37 and facets 46 between washer
20 36 and cage 30.

21
22 **[0033]** The nut assembly 18 is tightened to the requisite torque to hold the two
23 components (A) and (B) with a wrench in a conventional manner.

24
25 **[0034]** In use, if the bolt 12 extends due to the axial loads placed upon it, relative rotation
26 between cage 30 and body 20 will cause the ridges 48 to engage and the facets 46 of opposed
27 faces to slide across one another. The washer 37 is carried with the body 20 by the virtue of the
28 engagement of the serrations 55 with the undersurface 28 to cause relative rotation between cam
29 surfaces 42,42'. This induces an axial displacement between the faces, which is greater than the

1 axial displacement provided by a corresponding rotation of the body 20 on the shank 16. As
2 such a binding or interference is provided between the components and an unintentional
3 separation is inhibited.

4
5 **[0035]** To remove the nut assembly 18, sufficient torque is applied to rotate the nut and
6 cup conjointly and release the tension in the bolt.

7
8 **[0036]** During tightening, the serrations 55 engage the underside 28 of body 20 and
9 transmit the torque through the washers 36, 37. However, the serrations 55 do not cause
10 significant damage to the undersurface 28. The separate washer 37 permits the cams 42 to be
11 formed from a harder material and therefore ensure that they retain their functionality for
12 repeated applications.

13
14 **[0037]** It will be appreciated that this arrangement may also be incorporated into a nut in
15 which the body 20 is formed with a conical protrusion for centering the fastener on a workpiece.

16
17 **[0038]** The arrangement depicted in figures 1 to 5 is referred to as a four-piece
18 arrangement because it includes the nut 17, two washers 36, 37 and cage 30. A three-piece
19 arrangement may also be produced, as shown in figures 6 and 7 wherein the washer 36 is
20 eliminated so that the cam surface 42 of the washer 37 and the cam surface 44 on inside bottom
21 surface of the cage 30 engage. Each are produced with oppositely directed coarse cams which
22 are complementary to each other.

23
24 **[0039]** In this case, the cage 30c has fine serrations 55'c, angled at 15° with respect to a
25 radial plane on the outside bottom of the cage 30c. The serrations 55'c are directed oppositely to
26 the facets 46c that are located on the inside bottom of the cage 30c. The serrations 55'c engage
27 with the workpiece (A) and stop the cage 30c from moving. Similarly, the serration 55c engage
28 the undersurface 28 of the body 20 to inhibit relative rotation between the body 20 and washer

1 37. Accordingly, when subject to vibration, the coarse cams move up the incline and lock the
2 nut 17.

3
4 **[0040]** In each of the above embodiments a hexagonal body has been illustrated but it
5 will be recognized that other forms of nut may be used such as barrel nuts with longitudinal
6 grooves or other commonly available forms. It will also be appreciated that the fastener 10 may
7 be incorporated in to the head of a bolt rather than a nut with the underside of the head serving as
8 the undersurface 28 and the cage extending about the head. Such an arrangement may be used
9 with conventional hexagonal heads or other forms such as socket or domed headed bolts

10
11 **[0041]** The nut assemblies of Figures 1 through 5 or 6 and 7 may also be used
12 advantageously with studs secured in a blind hole and is particularly beneficial when used with a
13 tension control splined tip.

14
15 **[0042]** In certain configurations it has been found that there is sufficient elasticity in the
16 threaded shank 16 to allow the nut 18 to be undone by driving it over the facets 46. To avoid this
17 a further embodiment is shown in Figures 8 and 9 of a fastener having either a three-piece
18 arrangement similar to that shown in PCT application CA99/00985 (i.e. with the washer 37 and
19 serrations 55 omitted) or with a configuration as shown in figures 1 to 5. Like reference numerals
20 will be used to identify like components with a suffix "h" added for clarity. In the embodiment
21 shown in Figure 8, the peripheral sidewall 34h of the cage 30h is formed with a lower cylindrical
22 portion 94 and an upper frustoconical portion 96. A circlip 90 is located within the cage 30h
23 between the upper inclined surface 29h of flared skirt 26h and the inwardly directed inclined
24 surface 98 of frusto-conical portion 96. Circlip 90 is typically a flat band, having a "C"
25 configuration to allow flexure to reduce the diameter of the circlip 90.

26
27 **[0043]** Circlip 90 is dimensioned to limit the axial displacement available between cage
28 30h and body 20h of nut assembly 18h. As can be seen in figure 7, the circlip 90 is positioned
29 adjacent the transition between the portions 94,96 of the sidewall 34h so that relative axial

1 movement of the body 20h away from bottom wall 32h will attempt to reduce the diameter of the
2 circlip 90. The fastener 10h is assembled by inserting washer 36h into cage 30h, the body 20h
3 then being placed on washer 36. In the preferred assemblage, circlip 90 is then placed on body
4 20h and the sidewall 34h of cage 30h is then radially inwardly displaced to overlap the upper
5 surface 29h of flared skirt 26h.

6
7 **[0044]** In the alternative, circlip 90 may be introduced into cage 30h after the sidewalls
8 34h have been radially displaced. In this case, on assembly of the fastener, the ends of circlip 90
9 are compressed toward one another decreasing the radius of the circlip for installation within
10 cage 30h. When the ends are released, circlip 90 expands with the tensioned band returning to
11 the original configuration, and is retained within cage 30h.

12
13 **[0045]** Upon application of a reverse torque to the fastener 10h, opposed camming
14 surfaces provided by the facets 46h of washer 36h and end face 28h of body 20h slide relative to
15 one another as described in figure 3 to induce a relative axial displacement. The upper surface
16 29h engages with the circlip 90 to limit the axial displacement and thereby relative rotation.
17 Further rotation requires displacement of the circlip 90 relative to the cage 34h which is inhibited
18 by the compressive and friction forces. The conical portion 96 requires a progressive
19 compression of the circlip 90, as it is axially displaced, thereby presenting a progressively
20 increasing force. The circlip 90 provides an abutment that limits the axial displacement to a
21 height less than that of the ridge 48h. The force required to cause further elongation of the shank
22 16h is thus dramatically increased to inhibit removal of the nut assembly 18h. In the preferred
23 embodiment the allowable axial displacement is limited by the circlip 90 to one fourth the height
24 of the ridges 48h.

25
26 **[0046]** The circlip 90 is intended to prevent the removal of the fastener once installed. In
27 the event, that removal of the fastener is desired, circlip 90 is removed from the cage 30h by
28 circlip pliers, and the fastener 10h is removed as previously described. Upon reassembly, the
29 circlip 90 may be replaced or, preferably a new nut assembly is utilised.

1

2 **[0047]** A two-piece fastener arrangement may also be produced, though not shown,
3 wherein washer 36 is eliminated such that the cam surface 42 of nut 17 and cam surface 44 on
4 the inside bottom surface of cage 30 engage. Each of these cam surfaces is produced with
5 oppositely directed course cams which are complementary to one another. The circlip 90 is
6 located between the cage 30 and flared skirt 26 as described above. The provision of circlip 90
7 causes body 20 and washer 26 to remain in a substantially fixed relationship within cage 30 as
8 circlip 90 limits the potential axial displacement of same. If required, the serration's may be
9 provided on the lower face of the cage as described with reference to Figures 5 and 6.

10

11 **[0048]** The nut assembly 18 detailed in Figure 17 has frusto conical upper portions 96 of
12 sidewalls 34h which may be formed using the tool 100 shown in Figure 9. The tool 100 includes
13 a cylindrical barrel 102 with an internal cavity 104. The cavity 104 is formed by three
14 counterbores 106, 108, 110. The counterbores 106, 108, 110 are arranged in a step-like and
15 interconnected by radiussed fillet 112, 114 respectively. The outermost bore 106 is dimensioned
16 to correspond to the diameter of the lower cylindrical portion 94 of cage 30 so that the
17 undeformed peripheral wall 34 is a snug fit within the counterbore. The counterbores 108, 110 are
18 adapted to receive the nut 22 and shank 16 respectively in a freely fitting manner.

19

20 **[0049]** To radially displace the sidewalls 34h of cage 30h and form the frusto-conical
21 portion 96, tool 100 is placed over the top outer edges of cage 30h so as to receive the peripheral
22 portion in the counterbore 106 with the washer 36h, body 20h and circlip 90 located within the
23 cage 30h. On application of downward force on tool 100, the upper edge of the sidewall 34h is
24 forced into the radiussed fillet 112 and deflected inwardly in a uniform manner. This uniform
25 application of force by tool 100 avoids the formation of local deformations as in the previously
26 described embodiments, and enables a continuous fold in the cage material.

27

28 **[0050]** Tool 100 may be used in combination with fasteners having a variety of different
29 diameters and the radius adjusted to provide the required deflection.

1
2 [0051] It will be seen therefore that a simple yet effective fastener has been described
3 that provides the requisite resistance to vibration and at the same time is relatively easy to
4 manufacture.
5

1 **THE EMBODIMENTS OF THE INVENTION IN WHICH AN EXCLUSIVE PROPERTY OR PRIVILEGE**
2 **IS CLAIMED ARE DEFINED AS FOLLOWS:**

- 3
- 4 1) A fastener comprising a body having a planar end face, a cage rotatably secured to said
5 body and having a radial face directed toward said end face and side walls extending
6 toward and overlying a portion of said body to inhibit axial separation, and a washer
7 interposed between said body and said cage, said washer having a pair of oppositely
8 directed faces, one of said faces being directed toward said planar end face of said body
9 and having serrations formed thereon for engagement with said planar end face to inhibit
10 relative rotation therebetween, and the other of said faces being directed toward said
11 radial face of said cage and having a cam surface formed thereon, said cam surface
12 engaging a complementary cam surface on an oppositely directed face to induce relative
13 axial movement upon rotation between said faces.
- 14
- 15 2) A fastener according to claim 1 wherein said complementary cam surface is formed on
16 said radial face of said cage.
- 17
- 18 3) A fastener according to claim 2 wherein said cage has an outer surface oppositely
19 directed to said radial face and serrations are formed on said outer surface.
- 20
- 21 4) A fastener according to claim 1 wherein said complementary cam surface is formed on a
22 second washer interposed between said radial face and said other of said faces.
- 23
- 24 5) A fastener according to claim 4 wherein said radial face and said second washer have
25 opposed faces and a second set of complementary cam surfaces are formed on said
26 opposed surfaces to induce axial displacement upon relative rotation therebetween.
- 27
- 28 6) A fastener according to any one of Claims 1 to 5 wherein said body has a flared skirt
29 adjacent said radial face and said side walls overlap said skirt
- 30

- 1 7) A fastener according to Claim 6 wherein said body is a nut having planar flanks to permit
2 torque transmission thereto.
3
4
- 5 8) A fastener according to anyone of Claims 1 to 7 wherein each of said cam surfaces
6 include a plurality of inclined facets distributed about an axis of rotation.
7
- 8 9) A fastener according to Claim 8 wherein said facets are interconnected by ridges to
9 provide a torque-transmitting abutment between said faces.
10
- 11 10) A fastener according to Claim 5 wherein said cam surfaces on opposite sides of said
12 second washer are different.
13
- 14 11) A fastener according to Claim 10 wherein said facets associated with one of said cam
15 surfaces are inclined of different length to facets associated with the other of said cam
16 surfaces.
17
- 18 12) A fastener according to Claim 10 wherein said body has a plurality of flats formed
19 thereon to define a polygonal body and the number of said facets is an integral multiple
20 of the number of flats.
21
- 22 13) A fastener according to claim 1 wherein said serrations are asymmetric and extend
23 substantially continuously across said surface, each of said serrations having an inclined
24 facet and a generally axial end face and being oppositely directed to said cam surface.
25
- 26 14) A fastener according to Claim 13 wherein said facets are disposed at 15° to a radial plane.
27
28

- 1 15) A fastener comprising a body having an end face, a cage rotatably secured to said body
2 and having a radial face directed toward said end face and side walls extending toward
3 and overlying a portion of said body, said radial face and said end face being
4 interconnected by cam surfaces formed thereon and operable to induce relative axial
5 movement upon relative rotation between said faces, and an abutment between said cage
6 and said body to limit axial separation therebetween.
7
- 8 16) A fastener according to claim 15 wherein said abutment is selectively removable to
9 permit increased axial movement between said body and cage.
10
- 11 17) A fastener according to claim 15 wherein a washer is interposed between said body and
12 said cage, said washer having a pair of oppositely directed faces, one of which is directed
13 toward said end face of said body and the other of which is directed toward said radial
14 face of said cage, opposed faces of said fastener having complementary cam surfaces
15 thereon to induce relative axial movement between said body and said cage.
16
- 17 18) A fastener according to claim 17 wherein said abutment is selectively removable to
18 permit increased axial movement between said body and cage.
19
- 20 19) A fastener according to claim 18 wherein said abutment is resilient to facilitate insertion
21 between said cage and said body.
22
- 23 20) A fastener according to claim 19 wherein said cage has an inclined wall extending across
24 but spaced from said body and said abutment is removably secured between said inclined
25 wall and said body.
26
- 27 21) A fastener according to Claim 20 wherein said body has a flared skirt and said side walls
28 overlap said skirt.
29

- 1 22) A fastener according to Claim 21 wherein said flared skirt is surmounted by a nut having
2 planar flanks to permit torque transmission thereto.
3
- 4 23) A fastener according to Claim 22 wherein said complementary cam surfaces include a
5 plurality of facets inclined to a radial plane and interconnected by ridges to provide a
6 torque-transmitting abutment between said faces.
7
- 8 24) A fastener according to Claim 22 wherein said cam surfaces associated with respective
9 ones of said opposed pairs of faces are different.
10
- 11 25) A fastener assembly for securing a pair of components to one another, said fastener
12 assembly including a bolt having a head with a first end face directed toward one of said
13 components and a threaded shank depending from said head, a nut having a body and a
14 second end face directed toward another of said components, said body being threaded to
15 receive said shank, a cage secured to one of said head and said body and having a radial
16 face extending across a respective one of said end faces, an abutment acting between said
17 cage and said body to limit relative axial movement therebetween and a washer
18 interposed between said cage and said end face, said washer having a pair of oppositely
19 directed faces, one of which is directed toward said one end face and the other of which is
20 directed toward said radial face of said cage, opposed pairs of said faces having
21 complementary cam surfaces formed thereon to induce axial movement upon relative
22 rotation between said faces.
23
- 24 26) A fastener according to claim 25 wherein said abutment is selectively removable to
25 permit increased axial movement between said body and cage.
26
- 27 27) A fastener according to claim 26 wherein a washer is interposed between said body and
28 said cage, said washer having a pair of oppositely directed faces, one of which is directed
29 toward said end face of said body and the other of which is directed toward said radial

- 1 face of said cage, opposed faces of said fastener having complementary cam surfaces
2 thereon to induce relative axial movement between said body and said cage.
3
- 4 28) A fastener according to claim 27 wherein said abutment is selectively removable to
5 permit increased axial movement between said body and cage.
6
- 7 29) A fastener according to claim 28 wherein said abutment is resilient to facilitate insertion
8 between said cage and said body.
9
- 10 30) A fastener according to claim 29 wherein said cage has an inclined wall extending across
11 but spaced from said body and said abutment is removably secured between said inclined
12 wall and said body.
13
- 14 31) A fastener according to Claim 30 wherein said body has a flared skirt and said side walls
15 overlap said skirt.
16
- 17 32) A fastener according to Claim 31 wherein said flared skirt is surmounted by a nut having
18 planar flanks to permit torque transmission thereto.
19
- 20 33) A fastener according to Claim 30 wherein said complementary cam surfaces include a
21 plurality of facets inclined to a radial plane and interconnected by ridges to provide a
22 torque-transmitting abutment between said faces.
23
- 24 34) A fastener according to Claim 33 wherein said cam surfaces associated with respective
25 ones of said opposed pairs of faces are different.
26
27
28

1/5

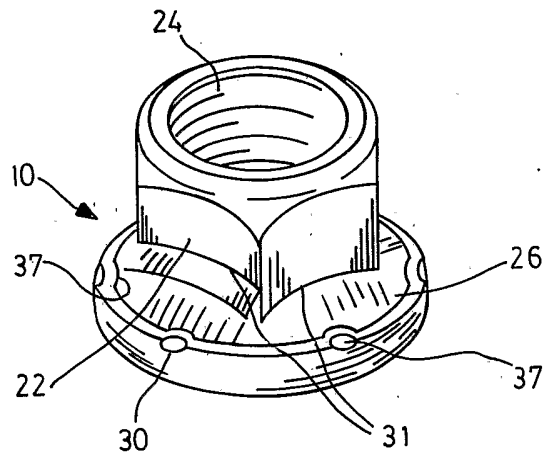

FIG. 1

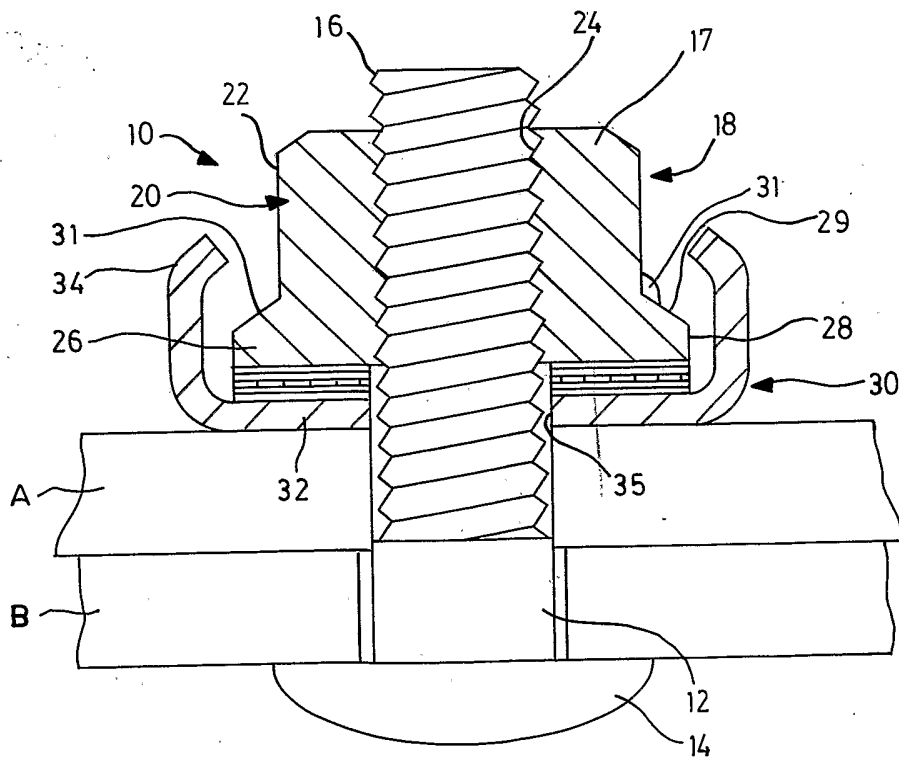

FIG. 2

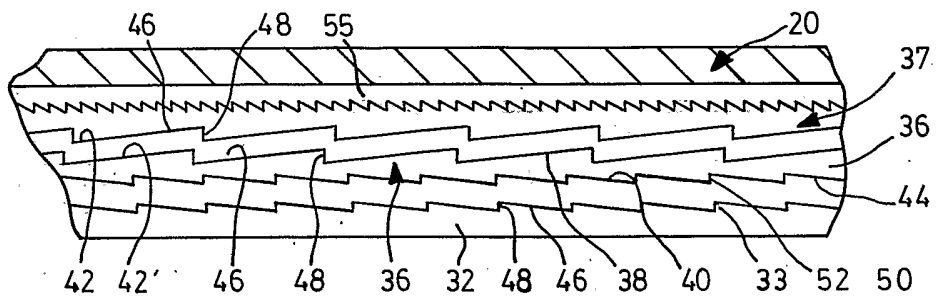

FIG. 3

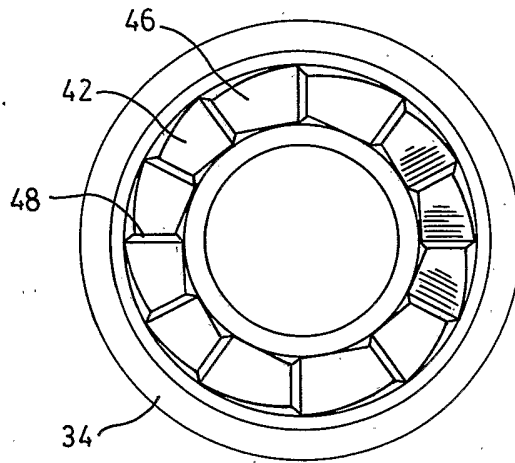

FIG. 4

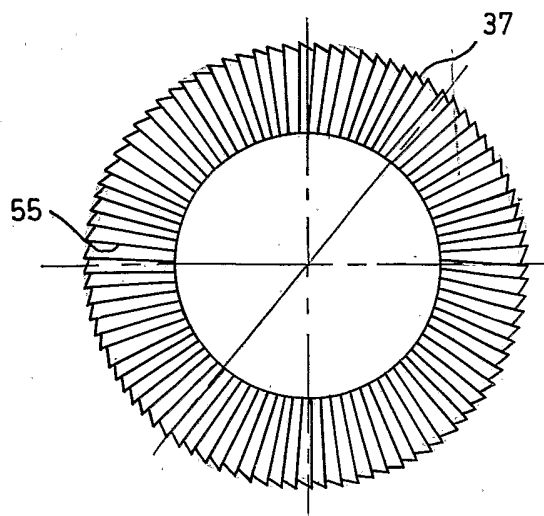
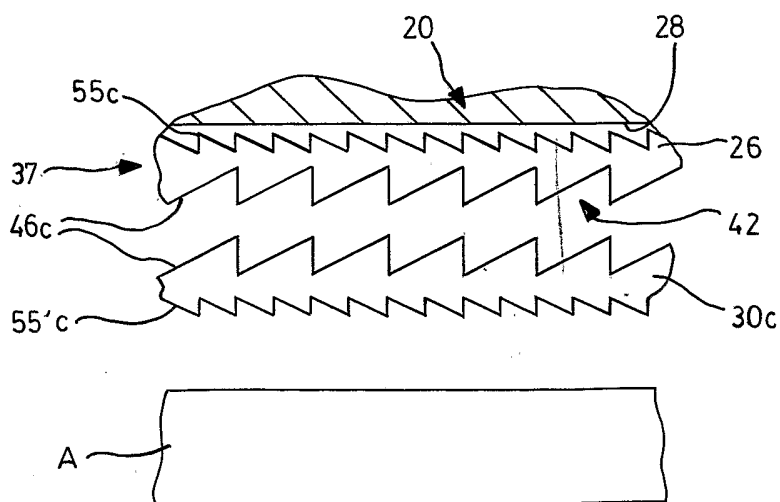
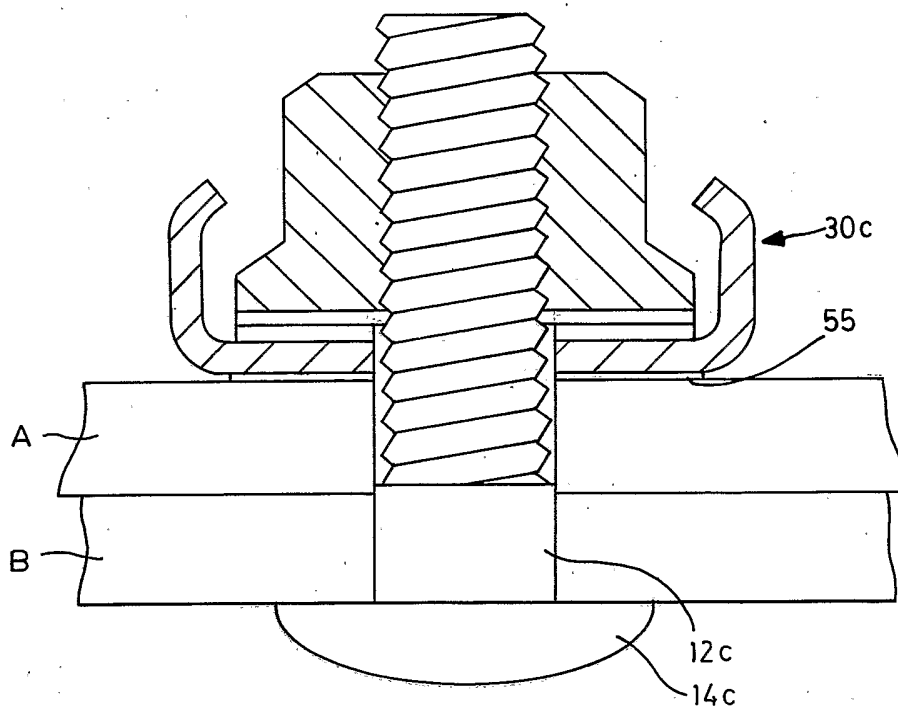

FIG. 5



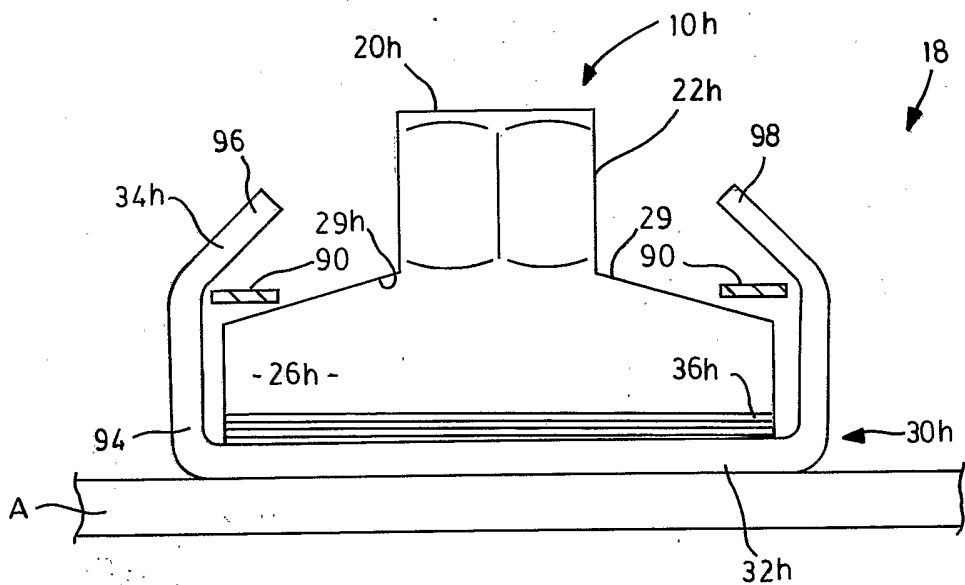

FIG. 8

5/5

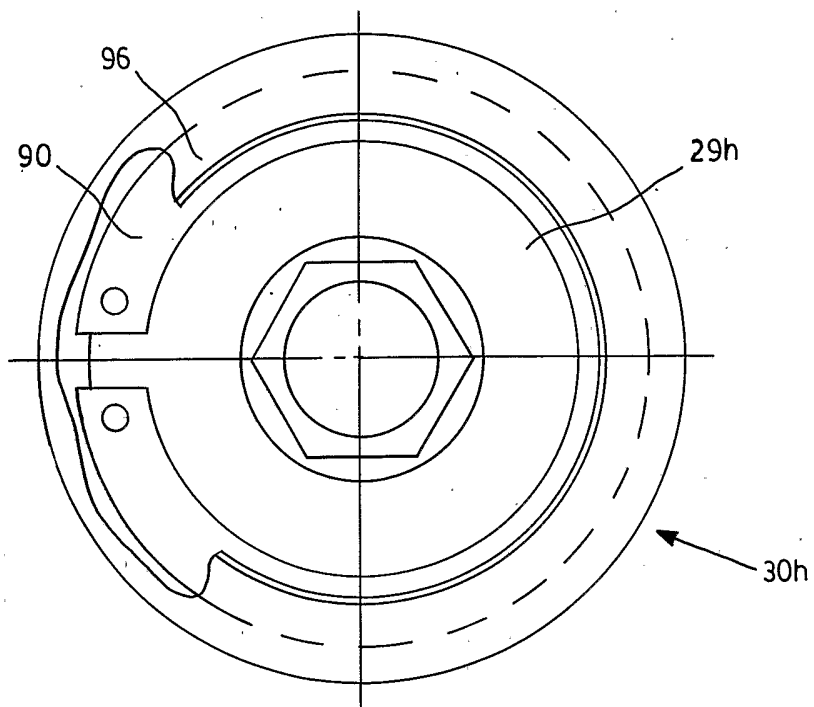

FIG. 9

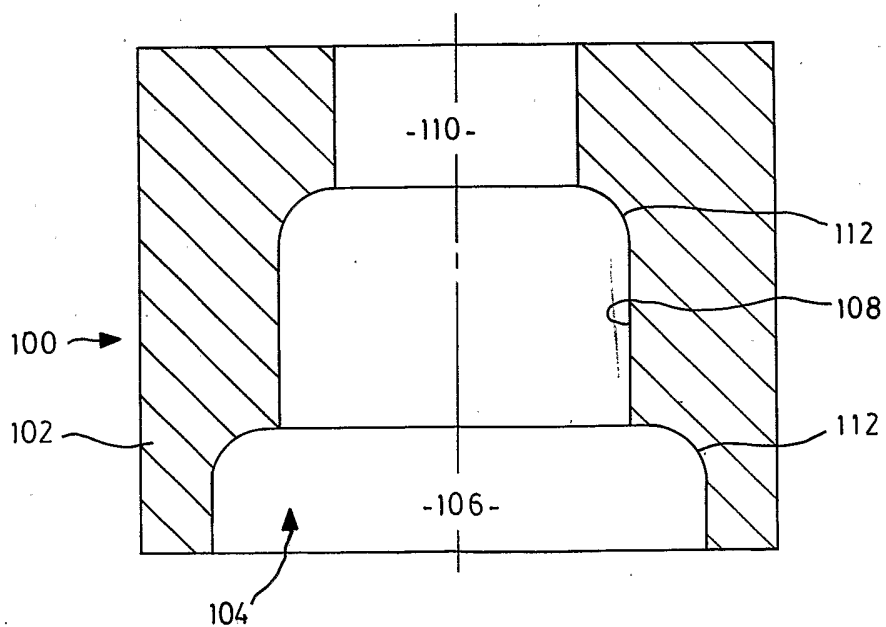

FIG. 10

INTERNATIONAL SEARCH REPORT

International Application No
PCT/CA 03/00769

A. CLASSIFICATION OF SUBJECT MATTER

IPC 7 F16B39/282 F16B39/24 F16B37/04 F16B21/18

According to International Patent Classification (IPC) or to both national classification and IPC

B. FIELDS SEARCHED

Minimum documentation searched (classification system followed by classification symbols)
IPC 7 F16B

Documentation searched other than minimum documentation to the extent that such documents are included in the fields searched

Electronic data base consulted during the international search (name of data base and, where practical, search terms used)

EPO-Internal

C. DOCUMENTS CONSIDERED TO BE RELEVANT

Category °	Citation of document, with indication, where appropriate, of the relevant passages	Relevant to claim No.
X	GB 2 343 228 A (DUOCAM INC) 3 May 2000 (2000-05-03) the whole document ---	1-34
X	US 5 688 091 A (MCKINLAY ALISTAIR N) 18 November 1997 (1997-11-18) cited in the application	15,16
A	column 2, line 41 - line 63 column 3, line 23 - column 4, line 3 figures 1-7 ---	1,25
A	US 5 066 180 A (LANG CHARLES F ET AL) 19 November 1991 (1991-11-19) column 2, line 22 - line 27 figures -----	16,18,26

 Further documents are listed in the continuation of box C. Patent family members are listed in annex.

° Special categories of cited documents :

"A" document defining the general state of the art which is not considered to be of particular relevance

"E" earlier document but published on or after the international filing date

"L" document which may throw doubts on priority claim(s) or which is cited to establish the publication date of another citation or other special reason (as specified)

"O" document referring to an oral disclosure, use, exhibition or other means

"P" document published prior to the international filing date but later than the priority date claimed

"T" later document published after the international filing date or priority date and not in conflict with the application but cited to understand the principle or theory underlying the invention

"X" document of particular relevance; the claimed invention cannot be considered novel or cannot be considered to involve an inventive step when the document is taken alone

"Y" document of particular relevance; the claimed invention cannot be considered to involve an inventive step when the document is combined with one or more other such documents, such combination being obvious to a person skilled in the art.

"&" document member of the same patent family

Date of the actual completion of the international search

16 September 2003

Date of mailing of the international search report

23/09/2003

Name and mailing address of the ISA

European Patent Office, P.B. 5818 Patentlaan 2
NL - 2280 HV Rijswijk
Tel. (+31-70) 340-2040, Tx. 31 651 epo nl,
Fax: (+31-70) 340-3016

Authorized officer

Granger, H

INTERNATIONAL SEARCH REPORT

Information on patent family members

International Application No

PCT/CA 03/00769

Patent document cited in search report		Publication date	Patent family member(s)	Publication date
GB 2343228	A	03-05-2000	AU 6455099 A	22-05-2000
			CA 2349554 A1	11-05-2000
			WO 0026547 A1	11-05-2000
			CN 1325480 T	05-12-2001
			DE 19983684 T0	29-11-2001
			SE 514625 C2	26-03-2001
			SE 9903875 A	01-05-2000
			TW 442618 B	23-06-2001
			US 2002146299 A1	10-10-2002
US 5688091	A	18-11-1997	CA 2207205 A1	05-12-1998
			EP 0889251 A1	07-01-1999
			US 5626449 A	06-05-1997
			AT 208862 T	15-11-2001
			DE 69708272 D1	20-12-2001
			DE 69708272 T2	25-07-2002
			ES 2169293 T3	01-07-2002
US 5066180	A	19-11-1991	NONE	