

(19) **DANMARK**

(10) **DK/EP 2386443 T3**



(12) **Oversættelse af
europæisk patentskrift**

Patent- og
Varemærkestyrelsen

-
- (51) Int.Cl.: **B 60 P 3/04 (2006.01)** **B 62 D 33/04 (2006.01)** **F 42 B 12/48 (2006.01)**
F 42 B 12/50 (2006.01)
- (45) Oversættelsen bekendtgjort den: **2016-06-20**
- (80) Dato for Den Europæiske Patentmyndigheds bekendtgørelse om meddelelse af patentet: **2016-03-09**
- (86) Europæisk ansøgning nr.: **11165573.4**
- (86) Europæisk indleveringsdag: **2011-05-10**
- (87) Den europæiske ansøgnings publiceringsdag: **2011-11-16**
- (30) Prioritet: **2010-05-10 GB 201007762**
- (84) Designerede stater: **AL AT BE BG CH CY CZ DE DK EE ES FI FR GB GR HR HU IE IS IT LI LT LU LV MC MK MT NL NO PL PT RO RS SE SI SK SM TR**
- (73) Patenthaver: **Parkhouse Country Estates Limited, Houghtons Parkhouse Coachwork , Grisley Lane, Milnthorpe, Cumbria LA7 7RF, Storbritannien**
- (72) Opfinder: **Houghton, Michael John, Houghton-Parkhouse Ltd, Houghtons Parkhouse Coachwork, Grisley Lane, Milnthorpe, Cumbria LA7 7RF, Storbritannien**
- (74) Fuldmægtig i Danmark: **RWS Group, Europa House, Chiltern Park, Chiltern Hill, Chalfont St Peter, Bucks SL9 9FG, Storbritannien**
- (54) Benævnelse: **Forbedringer ved og i forhold til søjleenheder til transportvogne**
- (56) Fremdragne publikationer:
WO-A1-94/02337
CA-A1- 2 452 416
FR-A3- 2 530 558
US-A- 6 107 569
US-A1- 2006 108 832

DESCRIPTION

Field to the Invention

[0001] The present invention relates to livestock transporter pillar assemblies for use with livestock transporters, transporters comprising pillar assemblies and especially, but not limited to, pillar assemblies for use with livestock transporters and transporters for use in transporting livestock. The present invention further relates to associated methods.

Background to the invention

[0002] Trailers and other transporters for use in transporting livestock generally comprise a number of levels each level having a platform to support the livestock. Each level may be divided into sections along its length with one or more gates, the gates being shut to create separate pens for the livestock.

[0003] Such transporters enable livestock to be transported economically and efficiently. Transporters for supporting livestock may comprise an integrated cab plus transport area or comprise a trailer forming a livestock area to be towed behind a tractor unit.

[0004] The transporters are provided with a range of services including lighting, hydraulic or pneumatic supply lines and food and water supplies. The arrangement of services within known transporters may create difficulties cleaning the transporters and may also expose them to damage.

[0005] US 2006/108832 A1 discloses 'A trailer edge rail system for use with a trailer having a removable cover includes a mount having a first end adapted to be secured to an edge of the trailer. The mount also includes at least one protrusion extending generally upwardly and parallel to a face of the edge of the trailer. The protrusion acts as a guide and aids in preventing an object (such as a snowmobile or the like) from being loaded too close to or driven off the edge of the trailer. A lip extends generally outwardly and transverse to the protrusion. In the preferred embodiment, the first end includes a C-shaped bracket. Alternatively, the first end may be molded with the trailer. The edge-rail system also preferably includes a longitudinally disposed cavity sized and shaped to accept one or more wires, hoses, or lights.'

[0006] CA 2 452 416 A1 discloses 'A trailer for transporting live poultry hatchlings has a cargo space for containing a plurality of perforated hatchling containers. The hatchling containers are stacked to create a central passage for air flow along the length of the trailer from which the air is admitted into a side duct on each side of the trailer through apertures in each side wall of the cargo space. This creates a transverse flow of air through the hatchling containers. A variety of measures may be undertaken alone or in combination to promote a similar transverse flow of air at all positions along the length of the trailer. The size of the apertures, spacing between apertures, cross-sectional area of the side ducts, cross-sectional area of the cargo space, or a combination thereof, may be varied along the length of the trailer to promote a similar transverse flow of air at all positions along the length of the trailer. The air collected within the side ducts may be exhausted and/or at least a portion thereof may be recycled in order to maintain life sustaining environmental conditions within the trailer.'

[0007] It is an aim of the present invention to address at least one problem associated with the prior art, whether referred to herein or otherwise.

Summary of the Invention

[0008] According to a first aspect of the present invention there is provided a livestock transporter pillar assembly, the pillar assembly comprising a pillar adapted to carry livestock services internally, wherein the livestock services comprise a water supply and/or a food supply and/or a drainage means and/or a conduit for livestock effluent.

[0009] Suitably, services the pillar is adapted to carry internally include one or more of: water supply, food supply, drainage and electricity.

[0010] Suitably, the pillar defines a duct for carrying services. Suitably, the pillar comprises a cavity.

[0011] Suitably, the livestock transporter pillar assembly comprises a hollow pillar adapted to carry livestock services.

[0012] Suitably, the livestock transporter pillar assembly further comprises one or more livestock services located within the pillar.

[0013] Suitably, the livestock transporter pillar assembly comprises an electric power supply cable. Suitably, the livestock transporter pillar assembly comprises a water supply conduit. Suitably, the livestock transporter pillar assembly comprises a food supply conduit. Suitably, the livestock transporter pillar assembly comprises a hydraulic or pneumatic supply line. Suitably, the livestock transporter pillar assembly comprises lights. Suitably, the livestock transporter pillar assembly comprises a button console. Suitably, the livestock transporter pillar assembly comprises drainage means. Suitably, the livestock transporter pillar assembly comprises a conduit for livestock effluent.

[0014] Suitably, the livestock transporter pillar assembly comprises an electric power supply cable located within the pillar. Suitably, the livestock transporter pillar assembly comprises a water supply conduit located within the pillar. Suitably, the livestock transporter pillar assembly comprises a food supply conduit located within the pillar. Suitably, the livestock transporter pillar assembly comprises a hydraulic or pneumatic supply line located within the pillar. Suitably, the livestock transporter pillar assembly comprises lights located within the pillar. Suitably, the livestock transporter pillar assembly comprises a button console located within the pillar. Suitably, the livestock transporter pillar assembly comprises drainage means located within the pillar. Suitably, the livestock transporter pillar assembly comprises a conduit for livestock effluent located within the pillar.

[0015] Suitably, livestock control systems are located within the pillar. Suitably, sensors are located within the pillar.

[0016] Suitably, the livestock transporter pillar assembly comprises one or more supports for supporting a deck. Suitably, the pillar assembly comprises one or more supports which project from the pillar in a longitudinal direction of a transporter when in a supporting position. Suitably, the supports are moveable relative to the pillar to allow variable positioning of a deck. Suitably, the supports can be moved to lie internally of the pillar when in a non supporting position. Suitably, the pillar comprises apertures through which the supports can protrude.

[0017] Suitably, the pillar assembly comprises an actuating mechanism for adjusting the position of said supports and which actuating mechanism is located within the pillar. Suitably, hydraulic and or pneumatic and/or electrical components of the actuating mechanism are located within the pillar.

[0018] Suitably, an actuating mechanism is mounted in a the pillar, and a support for a deck is arranged to protrude from the pillar through an aperture defined therein when arranged in a supporting position. Suitably, the actuating mechanism is coupled to a blanking means, arranged to cover the aperture defined in the pillar when the support is arranged in the supporting position. Suitably, the blanking means comprises a seal to seal the pillar against ingress of fluids when the aperture is covered by the blanking means. Suitably, the blanking means comprises a seal to seal the pillar against ingress of water when the aperture is covered by the blanking means. Suitably, the blanking means is an extension from the support. Suitably the blanking means is arranged to move as one with the support. Suitably, the blanking means is formed integrally with the support. Suitably, the blanking means is a load bearing component arranged to prevent rotation of the support beyond the supporting position when the support is moved from a non-supporting position to the supporting position. According to a second aspect of the present invention there is provided a livestock transporter comprising a livestock transporter pillar assembly, the livestock transporter pillar assembly comprising a pillar adapted to carry livestock services internally.

[0019] Suitably, the livestock transporter further comprises one or more livestock services located within the pillar.

[0020] Suitably, the livestock transporter comprises a livestock transporter pillar assembly according to the first aspect.

[0021] According to a third aspect of the present invention there is provided a method of transporting livestock, said method comprising loading livestock into a livestock transporter according to the second aspect.

Brief Description of the Drawings

[0022] The present invention will now be described, by way of example only, and with reference to the following drawings, in which:

Figure 1 is an isometric view showing part of a transporter with the nearside side wall removed.

Description of the Preferred Embodiments

[0023] As illustrated by Figure 1 and a transporter 10 comprises a pillar assembly 20 comprising a pillar 30 defining a duct 40 for carrying services (not shown).

[0024] The pillar assembly comprises supports 50 for supporting a deck 60. The supports 50 protrude from the pillar 30 in a longitudinal direction of a transporter when in a supporting position. The pillar 30 comprises apertures 70 through which the supports 50 can protrude.

[0025] The supports 50 can be moved to lie internally of the pillar 30 when in a non supporting position. When the supports are in the supporting position blanking plates 80 cover the apertures 70 to restrict the ingress of dirt to the duct 40 of the pillar 30.

[0026] The pillar assembly 10 comprises an actuating mechanism 90 for adjusting the position of the supports 50 and said actuating mechanism 90 is located within the pillar.

[0027] It will be appreciated that preferred embodiments of the invention may provide for efficient transportation of livestock.

[0028] Services carried by the duct 40 include electrical cables and water supply conduits but these have been omitted from the drawing for clarity.

REFERENCES CITED IN THE DESCRIPTION

This list of references cited by the applicant is for the reader's convenience only. It does not form part of the European patent document. Even though great care has been taken in compiling the references, errors or omissions cannot be excluded and the EPO disclaims all liability in this regard.

Patent documents cited in the description

- [US2006108832A1 \[0005\]](#)
- [CA2452416A1 \[0006\]](#)

Patentkrav

1. Søjleenhed (20) til kreaturtransportvogne, hvilken søjleenhed (20) til kreaturtransportvogne omfatter en søjle (30), der er indrettet til at bære udstyr til kreaturer indvendigt, idet udstyret til kreaturer omfatter en vandtilførsel og/eller en fodertilførsel og/eller en afløbsanordning og/eller en rørledning til spildevand fra kreaturerne.
2. Søjleenhed (20) til kreaturtransportvogne ifølge krav 1, ved hvilken søjlen (30) definerer et rør (40) til at bære udstyret til kreaturerne.
3. Søjleenhed (20) til kreaturtransportvogne ifølge et hvilket som helst af de foregående krav, hvor søjleenheden (20) desuden omfatter et eller flere udstyr til kreaturer, der er placeret inden i søjlen (30).
4. Søjleenhed (20) til kreaturtransportvogne ifølge et hvilket som helst af de foregående krav, hvor søjleenheden (20) omfatter et elektrisk strømforsyningskabel, der er placeret inden i søjlen og/eller en hydraulisk eller pneumatisk forsyningsledning, der er placeret inden i søjlen og/eller belysningsanordninger, der er placeret inden i søjlen, og/eller et trykknappanel, der er placeret inden i søjlen (30).
5. Søjleenhed (20) til kreaturtransportvogne ifølge et hvilket som helst af de foregående krav, hvor der er placeret styresystemer til kreaturer inden i søjlen (30).
6. Søjleenhed (20) til kreaturtransportvogne ifølge et hvilket som helst af de foregående krav, hvor søjleenheden (20) til kreaturtransportvogne omfatter en eller flere støtteanordninger (50) til at understøtte en etage (60).
7. Søjleenhed (20) til kreaturtransportvogne ifølge krav 6,

ved hvilken støtteanordningerne (50) kan bevæges i forhold til søjlen (30) for at muliggøre en variabel positionering af etagen (60), og/eller ved hvilken støtteanordningerne (50) kan bevæges således, at de ligger inden i søjlen (30), når de
5 befinder sig i en ikke-understøttende position.

8. Søjleenhed (20) til kreaturtransportvogne ifølge krav 6 eller 7, hvor søjleenheden (20) til kreaturtransportvogne omfatter en aktiveringsmekanisme (90) til justering af
10 positionen af støtteanordningerne (50), hvilken aktiveringsmekanisme er placeret inden i søjlen (30).

9. Søjleenhed (20) til kreaturtransportvogne ifølge et hvilket som helst af kravene 6 til 9, ved hvilken
15 aktiveringsmekanismen (90) er monteret i søjlen (30), og en støtteanordning (50) til en etage (60) er indrettet til at rage frem fra søjlen (30) gennem en åbning (70), der er defineret i denne, når den er anbragt i en understøttende position.

20 10. Søjleenhed (20) til kreaturtransportvogne ifølge krav 9, ved hvilken aktiveringsmekanismen (90) er forbundet med en blindplade, der er indrettet til at overdække åbningen (70), der er defineret i søjlen (30), når støtteanordningen (50) er
25 anbragt i den understøttende position.

11. Søjleenhed (20) til kreaturtransportvogne ifølge krav 10, ved hvilken blindpladen omfatter en tætning til tætning af søjlen (30) i forhold til indtrængende væsker, når åbningen
30 (70) er overdækket af blindpladen, og/eller ved hvilken blindpladen er en bærende komponent, der er indrettet til at forhindre rotation af støtteanordningen (50) ud over den understøttende position, når støtteanordningen (50) bevæges fra en ikke-understøttende position til den understøttende
35 position.

12. Kreaturtransportvogn (10) ifølge krav 11, ved hvilken søjleenheden (20) til kreaturtransportvogne omfatter en

søjleenhed (20) til kreaturtransportvogne (20) ifølge et hvilket som helst af kravene 1 til 11.

13. Fremgangsmåde til transport af kreaturer, hvilken
5 fremgangsmåde omfatter læsning af kreaturer på transportvognen (10) ifølge krav 11 eller 12.

DRAWINGS

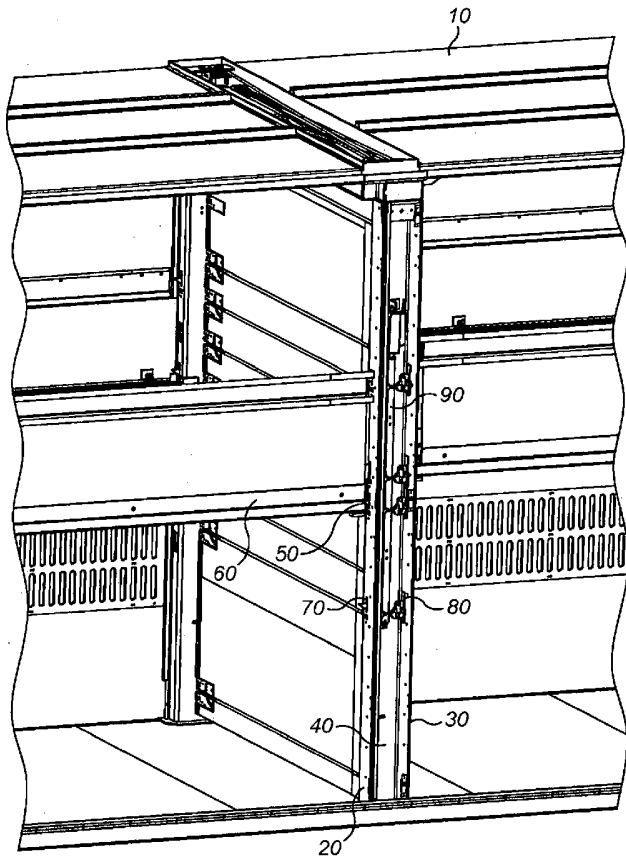

FIG. 1