



(12) **EUROPEAN PATENT APPLICATION**

(43) Date of publication:
15.07.2009 Bulletin 2009/29

(51) Int Cl.:
B65B 11/26 (2006.01) B65B 65/00 (2006.01)

(21) Application number: **08396002.1**

(22) Date of filing: **10.01.2008**

(84) Designated Contracting States:
AT BE BG CH CY CZ DE DK EE ES FI FR GB GR HR HU IE IS IT LI LT LU LV MC MT NL NO PL PT RO SE SI SK TR
 Designated Extension States:
AL BA MK RS

(72) Inventor: **Suokas, Jouni**
31300 Tammela (FI)

(74) Representative: **Nieminen, Taisto Tapani**
Patenttitoimisto T. Nieminen Oy,
Kehräsaari B
33200 Tampere (FI)

(71) Applicant: **Jomet OY**
30100 Forssa (FI)

(54) **Packing station for goods**

(57) A packing station for packing of goods (4) in wrapping (2) or in box (9), the station comprising a conveyor for moving of goods (4), an apparatus (6) for feeding and cutting off wrapping (2) in order to move it from a roll to said station, transfer gear (8) for moving the cardboard box billet to said station, and equipment to pack goods (4) either in wrapping (2) or in a box. The packing station comprises a first stop station (3) in which wrapping (2) or box billet (9) can alternatively be placed down-most

and goods (4) on top of it, said first stop station (3) still comprising transfer device (11) in order to move wrapping (2) or box billet (9) and goods on it to the second stop station, which is transfer gear (7) and comprises many conveyors 12, forming the box billets of goods (4) moving from one wrapping station (I) to another (II) - (IV), whereby the first wrapping station is intended for folding wrapper (2) or box billet (9) at least against two opposite sides of goods (4).

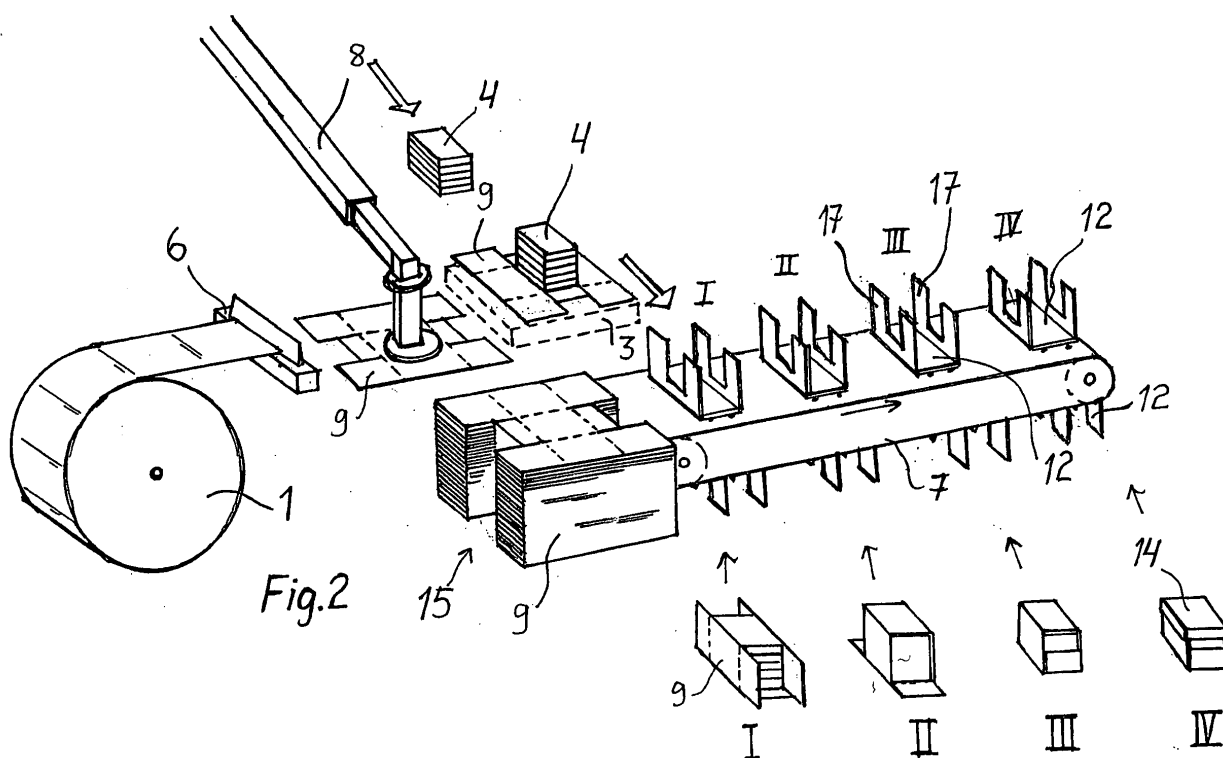

Description

[0001] The invention relates to a station for packing of goods into wrapping or into box, said packing station comprising a conveyor for moving the goods, an apparatus feeding and cutting off the wrapping in order to move it from a roll to said station, a transfer gear for moving a cardboard box billet to the station, and an equipment to pack the goods either into a wrapping or into a box.

[0002] Previously known are packing stations developed for packaging to be made by means of wrapping paper as well as packing stations for packaging to be made into a box. Characteristic of them is that it is possible to use only wrapping paper or corresponding cellophane in the first case and only box billets in the second case. Accordingly, if as ways of packaging are wrapped packing and box packing, for both ways there must be an own packing station and own wrappings or means to fold the box parts, gluing means and conveyors.

[0003] In order to get rid of the above presented disadvantage a new station is developed, which clears the above presented lack appeared in the packing industry, and characteristics for it is that the packing station comprises a first stop station, in which, the wrapping or the box billet can alternatively be placed down-most and the goods to be packed on it, the first station still comprising the wrapper or the box billet of the transfer device, and the goods on it to be transferred to the second station, which is a transfer gear and comprises many conveyors that form the goods, whereby the first wrapping station is intended for folding the wrapper or box billet to be folded at least against two opposite sides of the goods.

[0004] The advantage of a station according to the invention is that on the same station it is possible to pack the goods in a wrapper and in a cardboard box. Even as packaging apparatus there are almost the same equipment. The wrapping paper has a feeder of itself and the box billet a transfer device, and these ones in working order all the time and each in its turn ready for use. Hardly the packing station takes more space than a separate, with wrapper working packing station.

[0005] In the following the invention is disclosed with reference to the enclosed drawing, where:

Figure 1 shows schematically a packing station according to the invention by packaging that takes place with a wrapper,

Figure 2 shows in detail the station of figure 1 by packaging into box,

Figure 3 shows the transfer gear of the packing station,

Figure 4 shows the cover billet of the packing box,

Figure 5 shows the folding of the cardboard cover billet to a cover for the goods packing.

[0006] Figure 1 shows schematically a packing station according to the invention, where packaging of goods 4 with wrapping 2 is taking place. The goods to be packed

arrive by means of the conveyor (not shown) at the first stop station 3, on which before lifting goods 4 on it, a wrapper sheet is placed, said wrapper 2 cut off with cutter 6, running from roll 1, and, for instance, pulled with the lower or upper side vacuum conveyor on station 3. When goods 4 are on wrapper 2 the transfer device 11 of station 3 (figure(3) moves wrapper 2 and goods 4 to the upper side of the first wrapping station I of second stop station 7 and does in there the dropping of goods 4 and wrapping onto the conveyor 12 in this stop station. Conveyor 12 is a forked device, the opposite sides of which device fold up the opposite sides of wrapper 2 of goods 4, when the goods and the wrapper are placed in the fork. The sides of the fork are strap like, whereby, if needed, clamps 13 can go down to strap space.

[0007] In the second wrapping station II of stop station 7 of figure 1 the upper edges of wrapper 2 are folded on goods 4 with pressing means known as such. Further, while goods 4 move to wrapping station III, where all the four horizontal edges of wrapper 2 are folded so, that the lower edges are folded upward against goods 4 and the upper edges downward against goods 4. Next, said conveyor moves forward so, that the goods move to wrapping station IV, where all the vertical four edges of wrapper 2 are folded against goods 4. In applicable parts in wrapping stations I - IV, or between them, glue is sprayed on spots known as such, so the folded parts of wrapper 2 remain folded kept by the glue.

[0008] Goods 4, packed by means of wrapper 2, are moved forward from the conveyor of the second stop station 7 to the next station, for instance, wrapping station V, where band 5 is wrapped around it. Figure 1 shows the packaging by means of wrapper 2 only schematically without actuators to fold and form the wrapping, which are techniques previously known as such. Figure 2 shows in turn the same packing station of figure 1 packaging of same goods 4 into box billets 9. Box billets 9 are in bundle 15, from which they are moved by means of suction conveyor 8 one by one to the station 3. As in the case of wrapper 2, transfer gear 11 of the first stop station 3 moves, supported from the underneath, box billet 9 and the goods 4 upon it to the upper side of the first wrapping station I and does the dropping of box billet 9 and of Goods 4 on it onto conveyor 12 and in its fork. The transfer device 11 has plates pressing goods 4 from its sides or supporting L-formed plates 10 and clamp/bearing means 13. Thus, with the goods above the fork 12 of the transfer device the goods can be released from the pressing of clamps/bearings of plates 10 and dropped in fork 12. At the same time the edges of box billet 9 fold against the goods. According to figure 3 oblong rolls 19 fold up the edges of box billet 19 to facilitate their folding, when goods 4 are dropped into fork 12. In wrapping station I the box sides are folded up against the goods.

[0009] The conveyor of the second stop station 7 moves these goods to next wrapping station II, where the box parts in front and behind the goods are folded by means of folding apparatus. known as such, against the

front and back ends of the goods. Further, in the next wrapping station III the box parts still in the box bottom are folded up against the ends of the goods, and in needed stations glue is sprayed on these surfaces. In wrapping station IV to the upper side of goods 4 the box cover billet 14 is brought, which is let down on the goods, and by means of the folding apparatus according to figure 5, the edges of the box cover are folded down in order to form a cover furnished with edges. Glue is sprayed in the billet in necessary spots. In wrapping station IV goods 4 packed in box is for instance according to figure 1 moved to the next station, where it is wrapped with band 5.

[0010] Wrapping roll, cutter 6, and the transfer gears of wrapper can stay put when the goods is packed into box 9 and also box billets and their transfer gear 8 can stay put on packing into wrapping.

Claims

1. A packing station for packing of goods (4) in wrapping (2) or in box (9), the station comprising a conveyor for moving of goods (4), an apparatus (6) for feeding and cutting off wrapping (2) in order to move it from a roll to said station, transfer gear (8) for moving the cardboard box billet to said station, and equipment to pack goods (4) either in wrapping (2) or in a box, **characterized in that** the packing station comprises a first stop station (3) in which wrapping (2) or box billet (9) can alternatively be placed down-most and goods (4) on top of it, said first stop station (3) still comprising transfer device (11) in order to move wrapping (2) or box billet (9) and goods on it to the second stop station, which is transfer gear (7) and comprises many conveyors 12, forming the box billets of goods (4) moving from one wrapping station (I) to another (II) - (IV), whereby the first wrapping station is intended for folding wrapper (2) or box billet (9) at least against two opposite sides of goods (4).
2. A packing station according to claim 1 **characterized in that** the transfer gear (7) of the second stop station is arranged to move goods (4) from the first wrapping station (I) to another (II) - (IV), whereby there are on the wrapping stations apparatus for further folding of the sides of packing (2) or (9).
3. A packing station according to claim 1 **characterized in that** wrapping stations (II) - (IV) comprise, if necessary, glue spraying means for spraying glue on the foldings between the space of wrapper (2) or box billet (9).
4. A packing station according to claim 1 **characterized in that** the conveyors (12) of the second stop station comprise rods or plate parts (17) supporting goods (4), which are arranged to support goods (4) from its two opposite sides.
5. A packing station according to claim 1 **characterized in that** second stop station comprises a lifting apparatus for lifting of packed goods (4) from the last wrapping station (IV).
6. A packing station according to claim 1 **characterized in that** it comprises equipment (16) for folding the cardboard cover of billet (14), in order to spray glue in the cover foldings and to press it on the packing.
7. A packing station according to claim 1 **characterized in that** the transfer gear (11) of the first stop station (3) has a holder (1) supporting wrapper (2) or box billet (9) from the under side and plates (10) pressing goods (4) from its sides or L-formed mainly bearing plates, whereby on the upper side of wrapping station (I) there is, for dropping goods (4) to the said station, a holder (18), which can be removed and said plates (10) can be opened.

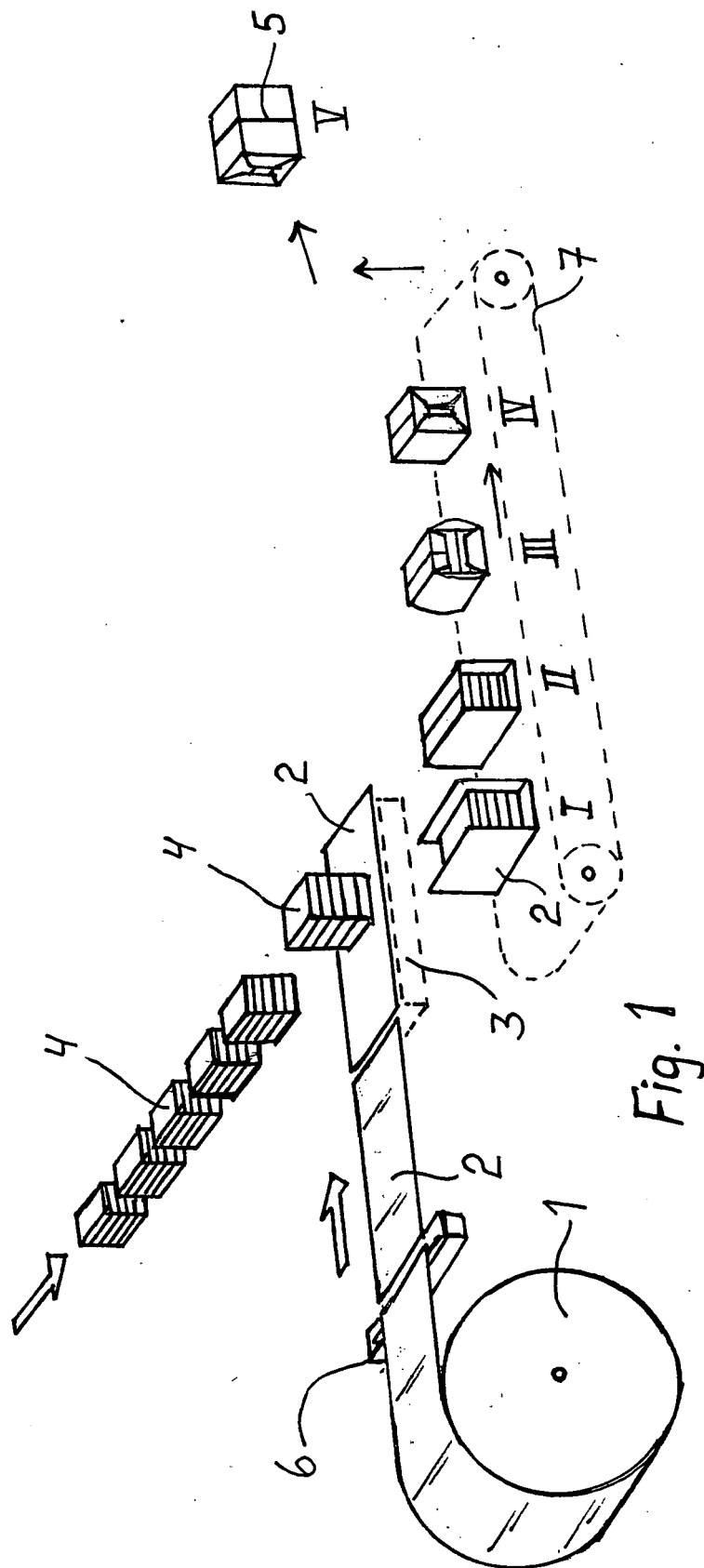



DOCUMENTS CONSIDERED TO BE RELEVANT			
Category	Citation of document with indication, where appropriate, of relevant passages	Relevant to claim	CLASSIFICATION OF THE APPLICATION (IPC)
Y	US 3 986 319 A (PUSKARZ STANLEY J ET AL) 19 October 1976 (1976-10-19) * the whole document *	1-7	INV. B65B11/26 B65B65/00
Y	EP 1 205 386 A (TOPACK VERPACKTECH GMBH [DE]) 15 May 2002 (2002-05-15) * figures 1,2 *	1-7	
A	US 2004/031236 A1 (BOIX JAEN JOSE [ES]) 19 February 2004 (2004-02-19)	1	
A	DE 40 18 140 C1 (KISTERS MASCHINENBAU GMBH, 4190 KLEVE, DE) 26 September 1991 (1991-09-26)	1	
			TECHNICAL FIELDS SEARCHED (IPC)
			B65B
The present search report has been drawn up for all claims			
Place of search Munich		Date of completion of the search 24 June 2008	Examiner Ungureanu, Mirela
CATEGORY OF CITED DOCUMENTS X : particularly relevant if taken alone Y : particularly relevant if combined with another document of the same category A : technological background O : non-written disclosure P : intermediate document		T : theory or principle underlying the invention E : earlier patent document, but published on, or after the filing date D : document cited in the application L : document cited for other reasons & : member of the same patent family, corresponding document	

2
EPO FORM 1503 03.82 (P04C01)

ANNEX TO THE EUROPEAN SEARCH REPORT
ON EUROPEAN PATENT APPLICATION NO.

EP 08 39 6002

This annex lists the patent family members relating to the patent documents cited in the above-mentioned European search report. The members are as contained in the European Patent Office EDP file on The European Patent Office is in no way liable for these particulars which are merely given for the purpose of information.

24-06-2008

Patent document cited in search report		Publication date	Patent family member(s)	Publication date
US 3986319	A	19-10-1976	NONE	

EP 1205386	A	15-05-2002	CN 1353077 A	12-06-2002
			DE 10056407 A1	23-05-2002
			JP 2002193505 A	10-07-2002
			PL 350647 A1	20-05-2002
			US 2002056257 A1	16-05-2002

US 2004031236	A1	19-02-2004	AT 371583 T	15-09-2007
			AU 2002358813 A1	30-06-2003
			BR 0207429 A	10-08-2004
			CA 2433924 A1	26-06-2003
			CN 1503751 A	09-06-2004
			DE 60222180 T2	21-05-2008
			EP 1468915 A1	20-10-2004
			WO 03051717 A1	26-06-2003
			ES 2292841 T3	16-03-2008
			ES 2222059 A1	16-01-2005
			JP 2005511439 T	28-04-2005
			MX PA03006880 A	15-10-2004
			NZ 527360 A	28-04-2006
			ZA 200305438 A	15-07-2004

DE 4018140	C1	26-09-1991	CA 2043941 A1	07-12-1991
			EP 0460374 A1	11-12-1991
			ES 2038524 T3	16-07-1993
			JP 4242503 A	31-08-1992
			US 5148654 A	22-09-1992
