

19



LE GOUVERNEMENT
DU GRAND-DUCHÉ DE LUXEMBOURG
Ministère de l'Économie

11

N° de publication :

LU101116

12

BREVET D'INVENTION

B1

21

N° de dépôt: LU101116

51

Int. Cl.:
B63B 15/00

22

Date de dépôt: 25/01/2018

30

Priorité:
08/06/2017 SI P-201700162

72

Inventeur(s):
SIFRER Erik – 1000 Ljubljana (Slovénie)

43

Date de mise à disposition du public: 22/07/2019

74

Mandataire(s):
MARKS & CLERK LLP – L-
1017 LUXEMBOURG (Luxembourg)

47

Date de délivrance: 26/08/2019

73

Titulaire(s):
MIDES DESIGN D.O.O. – 1000 Ljubljana (Slovénie)

54

SAIL CONSTRUCTION.

57 Abstract: Sail construction comprising foldable sail supports (2), a crossbeam (3), a holder (1.1), a sail (1), a bottom holder (4), ropes (4.3) and a bolt and a tackle system. The sail can be a self-inflatable sail (1 SN) designed similarly to paragliders, partially or fully inflatable. LU101116

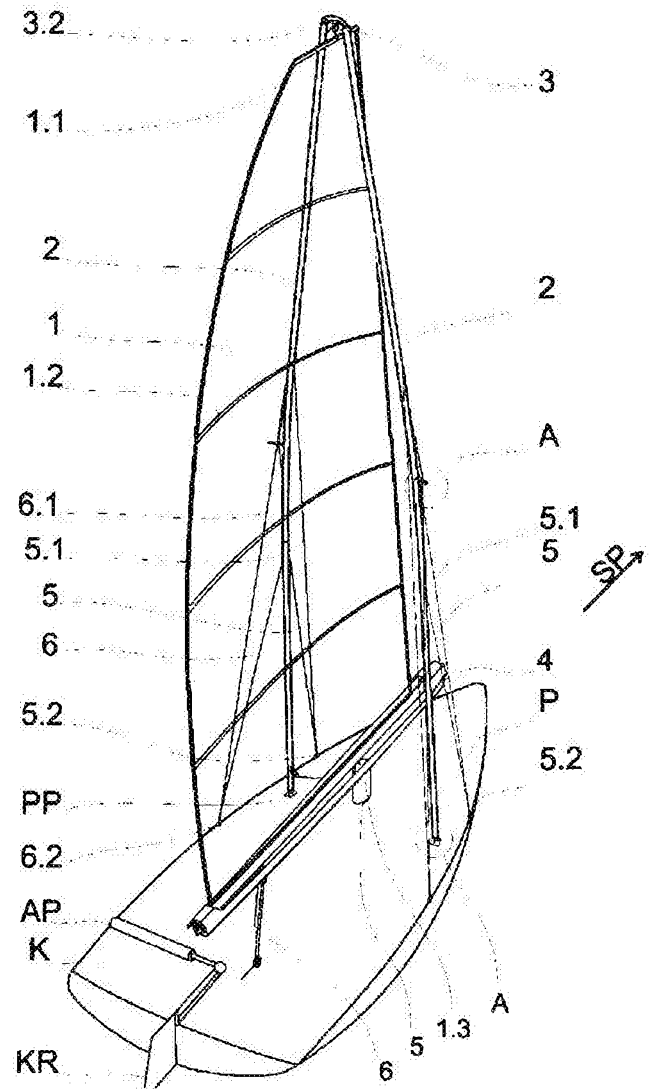

Figure 1

Sail construction

BACKGROUND

[0001] The invention concerns a sail construction without a mast replacing the role of the mast and at the same time allows setting up of all technically known sails for vessels or other means of transport.

The subject of the invention covers the entire system with elements that take over the function of the mast through its airfoils, and produce additional lift force in the direction of navigation of the vessel or other means of transport.

BRIEF SUMMARY OF THE INVENTION AND RELATED ART

[0002] The technical problem which is resolved by the invention is to provide such sail support construction that takes over the basic mast function and does not require auxiliary roping systems. In addition, it allows setting up of all known sail solutions.

The other technical problem which is resolved by the invention is that cross-sections of sail structure elements are designed as airfoils, which can, in parallel with the sail, also turn and reduce the air resistance and at the same time additionally increase lift force of the vessel in the direction of sailing due to the airfoil and rotation angle towards the wind incidence.

The fourth technical problem solved by the invention is that the sail structure can be simply folded down to a lower height, thereby facilitating the sailing of the vessel under bridges, etc.

Until now we have failed to observe any similar known solutions.

[0003] Below are listed the following patents from the SIPO patent database which outline and protect technical inventions in connection with the vessel sail and which are published under the following patent application numbers, namely:

Patent application No.: 22619

This patent shows a kayak with a retractable mast and sail. According to this patent, the mast can be quickly retracted, while the kayak can be used without the sail and vice versa.

This invention does not address the invention of the sail without a mast and therefore is not in any way related to our proposed invention, while the method of stacking the mast is completely different from that suggested by the proposed invention.

Patent application No.: 0989939

This patent deals with a sail with three light masts serving primarily for determining aerodynamic sail profile.

This patent does not address the sail without a mast and is entirely different from our invention.

Patent application No.: 9500182

This patent deals with a profiled sail. The proposed technical invention deals with the layout of aerodynamic ribs in the sail at the point of entry of the wind, which is located at the mast. It proposes wrapping the sail ribs around the mast.

This invention also does not address the invention of the sail without a mast and therefore is not in any way related to our proposed invention. In addition, the profiled sail is also designed in a completely differently way to that suggested by the proposed invention.

Patent application No.: 22790

This invention deals with similar technical inventions to the previous one, the only difference being that it proposes similar solutions for a trimaran sailing kayak.

This invention also does not address the invention of the sail without a mast and therefore is not in any way related to our proposed invention. The profiled sail of this invention is designed completely differently to that suggested by the proposed invention.

All of the above-mentioned patents represent known state of the art and do not offer technical solutions similar to our technical invention, which in essence does not use the mast for setting up the sail construction, which, composed of two supports, a connecting coupler and stays,

may be folded to a lower height and that the cross-sections of the supports are made in the form of airfoils which are freely movable around the longitudinal axis or are controlled around the longitudinal axis in line with the sail in order to achieve lift forces in the direction of navigation of the vessel or any other vehicle due to wind flow.

DETAILED DESCRIPTION OF THE INVENTION AND BRIEF DESCRIPTION OF THE DRAWINGS

[0004] According to the invention, the solution* to the problem of eliminating the main mast or all masts is to set up two sail supports on each side of the mast with an airfoil designed through their respective cross-section, which can rotate around the longitudinal axis of sail supports, while it can also be controlled via a system used to rotate airfoils of sail supports in a certain correlation with the sail. In the middle or near the middle both sail supports are designed so that they can be folded back or forth in relation to the axis of the vessel or vehicle in order to be able to reduce the height at least by half. For this purpose, the flexible section of the two sail supports is fitted with a special joint, around which they rotate. On the upper side, the sail supports are connected with a transverse joint with a function of connecting the supports and the function of tensioning the sail upwards.

The supports are fastened to the vessel or vehicle by means of stays. Stacking of supports can also be carried out by releasing the stays.

According to the invention, any sail of optional shape and profiles can be mounted to this construction.

For this purpose, we can also use an inflatable sail with pockets or pre-inflatable sail which can be inflated using a manual pump or a compressor in order to form an airfoil at low wind speed and thereby generate lift force for the sail.

The sail can be clamped in the axes of the incidence angle or the axes of the aerodynamic lift force or optionally.

The present invention is outlined in the embodiment and the figures that display:

Figure 1 – shows the side view of the entire vessel with the complete system and standard sail, which is clamped through the axis of the aerodynamic point of application of the forces

of the sail.

Figure 2 – shows the plan view of the entire vessel with the complete system and standard sail, which is clamped through the axis of the aerodynamic point of application of the forces of the sail.

Figure 3 – shows the vessel with multiple mounted systems for fastening the sail, as outlined by the invention.

Figure 4 – shows the stacking of the sail support via a rotary swivel joint in the middle of the sail support.

Figures 5A and 5 B – show the stacking of sail supports via a rotary swivel joint at the base or start of the sail support where only the stays 5.1 and 6.1 are installed. In this case, we do not necessarily need the stays 5 and 6.

Figures 6A and 6B – show detail A from the figure 4 which shows a sectional joint of the sail support which can also be mounted on the vessel's deck on the bottom base part of the sail support.

Figures 7A and 7B – shows the cross-section of the sail support where the airfoil and the manner of rotation around the longitudinal axis of the sail support are visible.

Figure 8 – shows the cross-section of a partially inflatable sail clamped into the sail construction without a mast.

Figure 9 – shows the cross-section of a fully inflatable sail clamped into the sail construction without a mast, where the wind flow is schematically shown.

Figure 10 – shows the cross-section of the self-inflatable sail and illustration of clamping of the sail to the holder 4.

Figure 11 – shows the cross-section of the holder 4 with a shaft 4.1 in connection with the sail 1 and rope 4.3 for lifting and lowering of the sail 1, and the holder 4 control system.

The sail construction without a central mast is set on a vessel P or another vehicle as a single system or several systems that can be optionally installed. One of those variants is shown in Figure 3.

A uniform system outlined by the invention consists of the following basic elements or components:

sail 1 which can in certain cases also be a self-inflatable sail 1 SN or a partially or fully inflatable sail 1 TN, two holders 1.1, two supports of the sail 2 which are installed on each side of the vessel P or sail 1, transversely to the sailing direction SP or vessel voyage direction P, connecting coupler 3 on which the upper block and tackle system 3.1 is mounted which is also the top fulcrum of the sail 1 that transfers the pre-tensioning force of the sail 1.

In addition, the technical assembly also consists of the bottom holder 4 which tensions the sail 1 downwards and also serves as a folding or storage compartment of the sail 1 and the fulcrum OK of the sail 1.

The sail 1 is tensioned over the rope, which can also be a braid or similar 4.3, that is in such a way that the holder 1.1, which is integrated in the upper section of the sail 1 is connected with a rope 4.3. The rope 4.3 runs through the pulley 3.1 or some other device installed on the connecting coupler 3 and on the deck of the vessel P, where it is fastened by any optional means. The second method is by allowing the rope 4.3 to run through the pulley 4.3.1, which is stopped on the deck of the vessel P, and which continues to run to the shaft 4.1 where the rope 4.3 is firmly fastened.

The shaft 4.1 is pivotally mounted in the middle of the cross-section of the holder 4 and can be driven by a manual drive 4.2.1 or by a motor drive 4.2.

This method is described in more detail below.

In the lower section, the sail 1 is clamped to the holder 4 with which it can be rolled onto the shaft 4.1 of the holder 4 or it is fastened optionally. If the holder 4 is fitted with a built-in shaft 4.1 for rolling the sail 1, the latter can optionally be shortened continuously during sailing by winding it onto the shaft 4.1 of the holder 4 and vice versa.

The sail supports 2 are fixed to the deck of the vessel P via known state of the art technical solutions, while the lower section of the supports of the sail 2 may be fastened to the deck of the vessel P via a special sectional joint 7 which is presented as detail A and is enlarged in Figures 6A and 6B.

The sail supports 2 can also be fitted with a built-in sectional joint 7 in the middle section of the length of the supports of the sail 2 or approximately in the middle section of the supports

of the sail 2.

If the supports of the sail 2 have built-in sectional joints 7 also or only in the middle section of the length, the prerequisite is that the fastening of the stays 5 and 6 is installed under the sectional joint 7. This is necessary because the upper part of the sail support 2 can be folded back towards the direction of navigation SP only by releasing the stay 5.1.

It is desirable that the upper fastening of the stays 5 and 6 onto the supports of the sail 2 is as close as possible to the bottom part of the sectional joint 7 in order to achieve the highest possible static strength of the connecting part of the stays 5 and 6 and the support of the sail 2.

The bottom as well as the top fastenings of the stays 5, 5.1, 6 and 6.1 can be designed using any known technical methods.

If the sectional joint 7 is installed only on the lower part of the support of the sail 2, it is possible to stack the entire support system of the sail 2 and the connecting coupler 3 back towards the direction of navigation SP by releasing both bottom fastenings 5.2 for both of the stays 5 and 5.1.

The supports of the sail 2 rotate around the sectional joint 7 at an angle that is required for the upper parts of the support of the sail 2, or the connecting coupler 3 to be seated firmly on the deck of the vessel P where special cam washers are installed that can carry the mass of the folded sail structure.

When stacking the supports of the sail 2 on a smaller vessel P they may also be in contact the surface of the water on which the vessel P is sailing. For this purpose, the connecting coupler 3 may be designed in such a way that it has an additional built-in float 3.2 with a sufficiently large volume ranging from 20 to 200 liters to retain the connecting coupler 3 or the folded sail construction above the water surface using the mass of displaced water. Such a folded structure is illustrated on Figures 5A and 5B.

In the case that the sectional joint 7 is fitted only at the approximate centre of the length of the sail supports 2, we can stack the upper part of the sail supports 2 with the connecting coupler 3 back towards the direction of navigation of the vessel P by releasing both bottom fastenings 5.2 of both stays 5.1.

The upper parts of the sail supports 2 rotate around the fulcrum of the sectional joint 7 by an

angle that is required to fit the upper part of the sail support 2, or the connecting coupler 3, to the lower holder 4 or to the special movable support for the float 3.1 to contact the water surface on the rear side of the vessel P. This type of folding is shown in Figures 4A and 4B.

The connecting coupler 7 may at the same time also be installed at both positions of the sail supports 2, as mentioned above. In this case, we can stack the sail supports 2 or the entire system by first releasing the lower fastenings 5.2 of the stays 5.1. Due to their own mass, the sail supports 2 rotate around the fulcrum of the sectional joint 7 back towards the stern K or in the opposite direction of the direction of navigation SP of the vessel P to the angle where the connecting coupler 3 seats on the holder 4 or onto special movable supports or similar.

We then also release the bottom fastenings 6.2 of the stays 6 and 6.1. Due to their own mass, the sail supports 2 that have previously already been stacked once also rotate around the fulcrums of the sectional joints 7 that are installed at the bottom in a forward direction towards the direction of navigation SP of the vessel P to such an angle that the edge of the sail support 2 sits on the deck of the vessel P or on the pre-installed movable holders that, while the connecting coupler 3 at the same time slides along the holder 4 or along the special movable holders in a forward direction towards the direction of the navigation SP of the vessel P. Such a method of stacking is shown in Figures 4A, 4B and 4C. With certain construction measurements, i.e. mainly with small vessels P, it is possible that the float 3.2 contacts the water surface before the vessel P does and holds the entire structure above the surface.

The sectional joint 7 is designed in such a way that the sail supports 2 can be rotated in one direction only by an angle of up to a maximum of 180 degrees. The sectional joint 7 is self-locking in the other direction of rotation.

The self-locking is performed in such a way that the fulcrum 7.1 of the sectional joint 7 is fitted on the side outside the cross-section of the sail support 2. However, the surfaces 7.2 and 7.3 of the sail support 2 are designed at such a position that the outstretched or open sail support 2 seats on the surfaces 7.2 and 7.3 in firm contact.

The surfaces 7.2 and 7.3 are joined and do not allow the rotation of the sectional joint 7 in the opposite direction as foreseen for stacking the sail support 2. This rotation around the sectional joint 7 is shown in Figures 6A and 6B.

Before stacking the sail supports 2, it is necessary to remove the sail 1 or store it into the

holder 4. If you fail to do this before stacking the sail supports 2, this may result in a breakage of the entire system or cause damage to the sail 1.

The sectional joints 7 are always installed in such a way that the axis 7.1 of the sectional joint 7 is perpendicular to the direction of stacking of sail supports 2, or perpendicular to the vessel's (P) symmetrical axis.

V If a sectional joint 7 is only installed on the bottom part of the sail support 2, or at the deck of the vessel P, it must be oriented so that the axis 7.1 of the sectional joint 7 is closer to the stern K of the vessel P.

This way, when the sail support 2 is stacked, the upper part of the sail support 2 is rotated backwards around the axis 7.1 of the sectional joint 7 towards the stern K of the vessel P, and the surfaces 7.2 and 7.3 separate.

V In the case two sectional joints 7 are also installed or are installed only in the approximate centre of the middle section of the support of the sail 2, they must be installed in such a way that the axis 7.2 of the upper sectional joint 7 is closer to the stern K of the vessel P, while the axis 7.2 of the lower sectional joint 7 is at a distance from the stern K of the vessel P closer to the bow of the vessel P.

The axes 7.2 of the sectional joints 7 must be installed in such a way that they are parallel to each other. If the axes are not parallel, relatively large forces can act on the axis 7.2 due to stacking which are transferred to the sail supports 2 as torsional forces and can damage the sail supports 2 or fulcrums PP of the sail supports 2 on the deck of the vessel P and the fastening between transverse joint 3 and sail supports 2.

In order to eliminate the tolerance of design and installation of the sectional joints 7 on the sail supports 2, the axis 7.2 is designed in such a way that the fit of the axis 7.2 in the sectional joint 7 is very loose, and laxity of the fit of the axis 7.2 in the hole of the sectional joint ranges from 0.5 to 5mm allowing torsional rotation in the range from 3 to 30 angular degrees.

Before starting the stacking of the sail supports 2 you must verify that the surfaces 7.2 and 7.3 of the sectional joint 7 are clean or that no foreign body is on these surfaces which would prevent a repeated rotation of the upper part of the sail support 2 or the entire sail support 2 to the basic position, where all parts of the sail support 2 which are installed under and above the

sectional joint 7 are parallel, or positioned along the same symmetrical axis running along the length of the sail support 2.

In the middle between the sail supports 2 or below the connecting coupler 3, the holder 4 is pivotally mounted on the deck of the vessel P which is used to tension the sail 1 and at the same time also as a rolling or storage compartment of the sail 1.

The holder 4 has a mounted shaft 4.1 in the middle, to which the sail 1 is rolled up during folding or shortening thereof, or during the unrolling procedure when unfolding the sail 1.

The rolling of the sail 1 can be carried out using an electric motor with a gearbox 4.2. When the bolt and tackle system with an endless rope 4.3 that is described below is not used, the gearbox must employ a self-locking mechanism so that the shaft 4.1 cannot unfold so that the sail 1 remains taut. The rolling or unrolling of the sail 1 can also be carried out manually using the lever 4.2.1 which drives the built-in self-locking gearbox which can be a worm gear or similar.

The sail 1 is fitted with a holder 1.1 at the top, to which the rope of the system 4.3 is fixed which tensions the sail 1 through the pulley 3.1 that is mounted on the connecting coupler 3.

The sail 1 is tensioned using a considerable force which also determines the sail profile 1 in the longitudinal direction.

Due to the aerodynamic lift forces of the sail 1, relatively large pretension forces of the sail 1 are generated, therefore all components for pretensioning of the sail 1 must be designed taking into account a considerable safety factor.

The sail 1 pull-out and folding system with the so-called endless rope 4.3 is designed in such a way that the rope 4.3 is fastened to the holder 1.1 of the sail 1 on one side which then runs downwards through the pulley 3.1 onto the pulley 4.3.1 directing the rope 4.3 towards the holder 4. On the holder 4, the rope runs through the pulley 4.3.2 onto the pulley 4.3.3 which directs it to the pulley 4.3.4. This pulley directs the rope 4.3 perpendicularly to the shaft 4.1 where the rope 4.3 is firmly fixed.

When folding the sail 1, turn the shaft 4.1 which is mounted into the holder 4. This way, the rope 4.3 of the sail 1 lowering and lifting system starts winding onto the shaft 4.1. At the same time, the sail 1 starts winding onto the shaft 4.1. Due to the same winding track of the rope and sail 1 onto the shaft 4.1, the rope 4.3 is always taut and keeps the sail 1 always taut

via the crosslink 1.1.

When the sail 1 is completely folded onto the shaft 4.1, it is stored in the holder 4. In this case, the rope 4.3 is also wound onto the shaft 4.1 in the holder 4.

When pulling out the sail 1, we follow the procedure in the opposite direction. By rotating the shaft 4.1 in the opposite direction, the rope of the system 4.3 pulling the sail 1 from the holder 4 via the pulley 3.1, begins to unroll. The sail 1 unfolds from the shaft 4.1 symmetrically to the rope of the system 4.3.

In this way, you can pull out the sail 1 to the desired height in a continuous manner. The trimming and pulling out of the sail 1 is carried out without ropes that would be an interfering element on the deck of the vessel P.

The pulling out or shortening or folding of the sail can be motor driven by an electric motor 4.2 or manually using the lever 4.2.1. In both situations a regular or self-locking gearbox with an integrated brake is used.

The use of the gearbox or the brake integrated with the gearbox 4.2 is desirable to additionally lock the rotation of the shaft 4.1, thereby enabling the force of pretensioning the sail 1, although the rope 4.3 is endless and pretensioned in order to prevent unrolling of the shaft 4.1.

When you do not use the continuous rolling/unrolling using the rope 4.3 as described above, but tension/lowering the sail 1 using the pulley 3.1 by means of an ordinary rope fixed on the deck of the vessel P, we must use self-locking a gearbox or gearbox with an integrated brake 4.2.

In the event that the electric motor 4.2 is used, the sail 1 can be completely automated and the trimming of the sail and the position of the helm KP of the vessel P can be connected via computer with the autopilot AP of the vessel P.

The holder 4 is fixed to the deck of the vessel P so that it can rotate around the control axis OK which can be at any chosen length of the holder 4. The fastening of the holder 4 to the deck of the vessel P can be carried out in a variety of ways, namely using all known technical methods, whereby it must be designed in such a way that it can easily transfer all the forces of pretensioning of the sail 1 and the forces generated by the aerodynamic forces and the wind resistance forces of the sail 1.

The holder 4 is fixed to the control axis OK so that it can freely, or with a torque of up to 50Nm, tilt transversely to the longitudinal axis in the direction S VOK within the limits of -25 to +25 angular degrees.

The movable fastening of the holder 4 to the control axis OK can be carried out using all known technical solutions with the condition that they can easily transfer all loads that occur due to the sail tension 1 and the aerodynamic forces of the sail 1 acting on the vessel P.

The tilting of the holder 4 in the direction of SVOK can be necessary in order to tension the sail 1 evenly over the entire surface of the sail 1 due to tensioning, particularly on the rear edge, since the holder 4 and with it the bottom clamping of the sail 1 adapts to the actual shape or dimensions of the selected sail.

To control the holder 4 around the VOK axis VOK which indirectly controls the sail 1, various systems can be used which represent known state of the art. The most basic system is shown in Figure 11 and represents the rope assembly AS which is wrapped around the bolt and tackle system, through which the rope is locked fixed on the deck of the vessel P.

The control can also be carried out in more simple ways such as by using a control rod which can be sectionally clamped at the rear end of the holder 4 or in a more sophisticated manner where the fulcrum OK of the holder 4 is clamped to the control gearbox with an electric motor or any other engine mechanism. The gearbox must either have an integrated brake or have a self-locking mechanism so that the positioned holder 4 stays in the desired location.

The control mechanism drive of the holder 4 can also be connected with the autopilot AP of the vessel P, or it can be controlled in any other way.

The airfoils 2.1 which are installed along the length of the two sail supports 2 can be designed as indicated in the Figure 7A or Figure 7B.

In the example shown in the Figure 7A a built-in tube 2.2 is located on the exit edge of the profile which increases the airfoil stability and prevents injuries to the crew when colliding with the exit edge of the airfoil 2.1 of the sail support 2.

The Figure 7B shows an airfoil without an integrated tube on the exit edge. However, both airfoil surfaces 2.1 are assembled to form a sharp edge.

The airfoil is mounted on the sail supports 2 and can freely rotate around them.

Free play between the airfoil 2.1 and sail support 2 ranges from 0.5mm to 15mm which is enough for the airfoil 2.1 not to get stuck to the sail support 2 profile even with small wind forces, but rotates freely in the direction of the slightest wind resistance SV.

The airfoils 2.1 can have free rotation owing to wind flow SV. This reduces wind resistance on the sail supports 2 and enables more efficient use of the vessel P.

Rotation of airfoils 2.1 of the sail supports 2 can also be executed through mechanical controls using any known method. In this case, it is desirable to rotate the airfoil 2.1 of the sail support 2 by exactly the same angle VP in order to obtain a higher lift force of the profile 2.1 in the direction of navigation SP of the vessel, and at the same time the minimum resistance force of the wind flowing around the airfoil.

The airfoils 2.1 control can be carried out in correlation with the rotation control VOK of the holder 4 or the sail 1 around the axis OK or an integrated stand-alone system can be used that turns the airfoils 2.1 for VP angles that offer optimum lift force in the direction of the vessel P and minimum air resistance in the direction of navigation SP of the vessel P.

✂ In this case, the control must be connected with the helm angle gauge, VOK angle of the holder 4 around the axis OK, speed gauge and angle of the wind SV, via a computer displaying information about the speed and course of the vessel P, the inclination of the vessel P from the autopilot AP.

The sail 1 can be single-layered, as is well known in most cases. By folding the sail 1 longitudinally by rolling it onto the shaft 4.1, the sail 1 can have built-in bars 1.2 that form airfoil cross-sections of the sail 1.

By using such a sail 1, the aerodynamic lift force of the sail 1 is greatly improved. There can be 10 pieces of bar 1.2 per linear metre of the sail 1.

Another feature of the sail which can be used with the present invention is the so-called inflatable sail 1 SN which has integrated pockets formed by the internal links PL of both layers of the self-inflatable sail 1 SN which are designed in a similar way as with paragliders.

This roughly means that the proposed invention allows the installation of segments of paragliders.

The construction of paragliders with integrated open, due to air flow, self-inflatable pockets which shape an airfoil, is technically known and is not outlined separately.

This airfoil shape of the self-inflatable sail 1 SN provides the so-called thick airfoils which

generate large lift forces at low wind speed SV. Therefore, the use of such a self-inflatable sail 1 SN is a far better choice than the use of a classical single-layer sail 1.

However, the use of such a self-inflatable sail 1 SN which has integrated self-inflatable pockets, is disabled or unfeasible in technical terms with vessels P which are equipped with a central mast since the self-inflatable sail 1 SN in this case cannot be freely hung in the construction, but is clamped to the mast with the front edge which in this case disrupts the aerodynamic potential of the self-inflatable sail 1 SN.

The Figure 10 shows a cross-section of the self-inflatable sail 1 SN with visible connections PJ on both layers of the sail.

The third sail feature that can be used in the proposed invention is the so-called inflatable sail 1 TN which can be inflated by overpressure using a manual pump or compressor. In this case, the inflatable sail 1 TN consists of chambers or has along the airfoil length built-in layer connections PJ between both layers which determine the shape of airfoils of the inflatable sail 1 TN along the entire length of the inflatable sail 1 TN.

The connections PJ can be carried out in a similar way as for connections PJ on the self-inflatable sail 1 SN, whereby in this case the inflatable sail 1 TN is completely closed off also at the entry and exit edges.

This type of sail 1 TN is shown in the Figure 9 which also illustrates wind flow SV.

The inflatable sail 1 TN can also be inflated only at the entry edge VR. This type is shown in the Figure 8. Such a sail 1 TN is called a partly-inflatable sail 1 TN. However, if the sail can be inflated throughout the cross-section, it is called a fully-inflatable sail 1 TN.

In the case of shortening, folding or rolling on the shaft 4.1 of inflatable sails 1 TN, the pressure in the inflatable sail 1 TN must be relieved. Having relieved the pressure, you can roll the inflatable sail 1 TN onto the shaft 4.1. When the inflatable sail 1 TN has been once again fixed with the rope 4.3, you can inflate it by using overpressure to achieve the desired airfoil.

Inflatable sails 1 TN are not specifically outlined since this represents the already known state of the art. However, it has not yet been used for this purpose, i.e. as a sail on vessels, because the central mast prevented this. The proposed invention also outlines and proposes the use of all described sail systems which range from classical single-layer with or without

bars, self-inflatable, as well as partially- or fully-inflatable ones.

Patentansprüche

1. Segelkonstruktion, **dadurch gekennzeichnet**, dass sie aus folgenden Hauptelementen besteht wie beispielsweise: den faltbaren Segelstützen (2), dem Querträger (3), dem Halter (1.1), dem Segel (1), dem unteren Halter (4), den Seilen (4.3) und dem Flaschenzug-System.
5
2. Segelkonstruktion, **dadurch gekennzeichnet**, dass das Segel 1 durch zwei elastisch vorgespannte Segelstützen (2) gestützt wird, welche abschnittsweise an beiden Seiten des Wasserfahrzeugs (P) an den beiden Punkten (PP) montiert sind, welche am oberen Ende mit dem Anschluss-Koppler (3) verbunden sind.
- 10 3. Segelkonstruktion nach Anspruch 1, **dadurch gekennzeichnet**, dass die Scheibe (3.1), durch welche ein Seil (4.3) zum Halter (1.1) des Segels (1) läuft, welcher dazu verwendet wird, das Segel (1) von Hand oder mechanisch unter Verwendung aller bekannten Verfahren zu heben oder zu senken, an dem Anschluss-Koppler (3) montiert ist.
- 15 4. Segelkonstruktion nach Anspruch 3, **dadurch gekennzeichnet**, dass ein Schwimmer (3.2) mit einem Volumen im Bereich von 20 bis 200 Litern an dem Anschluss-Koppler (3) installiert werden kann.
5. Segelkonstruktion nach Anspruch 1 und 2, **dadurch gekennzeichnet**, dass ein Seil (4.3) vom Halter (1.1) gezogen werden kann, wo es fest durch die Scheibe (3.1) geklemmt wird, zu der Scheibe (4.3.1), welche es zu einer anderen Scheibe (4.3.2) führt, welche es zu der Scheibe (4.3.3) am Halter (4) führt, wo diese Scheibe seine Richtung umlenkt und zu der Scheibe (4.3.4) am Halter (4) lenkt, welche wiederum das Seil (4.3) rechtwinklig zum Schaft (4.1) im Halter (4) umlenkt, wo das Seil (4.3) fest an den Schaft (4.1) geklemmt wird.
20
- 25 6. Segelkonstruktion nach Anspruch 1, **dadurch gekennzeichnet**, dass der untere Abschnitt des Segels (1) fest in den Halter (4) unter Verwendung eines beliebigen bekannten Verfahrens geklemmt ist.
7. Segelkonstruktion nach Anspruch 6, **dadurch gekennzeichnet**, dass der untere Abschnitt des Segels (1) fest an den Halter (4.1) geklemmt werden kann, welcher in der
30 Mitte des Halters (4) montiert ist.
8. Segelkonstruktion nach Anspruch 7, **dadurch gekennzeichnet**, dass das Segel (1) kontinuierlich aufgerollt und abgerollt werden kann unter Verwendung des Schafts (4.1), wobei der Schaft (4.1) die Vorspannungskräfte des Segels (1) und aerodynamische Komponenten der auf das Segel (1) einwirkenden Windkräfte überträgt.
- 35 9. Segelkonstruktion nach Anspruch 3 und 8, **dadurch gekennzeichnet**, dass, falls Aufrollen/Abrollen des Segels 1 in klassischer Manier verwendet wird, der Schaft (4.1) in der Erweiterung mit einem eingebauten, selbstverriegelnden Getriebe ausgerüstet ist, welches mit einem Hebel (4.2.1) aktiviert werden kann.

10. Segelkonstruktion nach Anspruch 3 und 9, **dadurch gekennzeichnet**, dass anstelle von oder neben dem manuellen Antrieb der Schaft (4.1) ebenfalls ein eingebautes Getriebe in der Erweiterung aufnehmen kann, welches einen selbstverriegelnden Mechanismus beinhalten muss oder eine integrierte Bremse besitzen muss, und durch
5 einen Elektromotor (4.2) angetrieben sein muss, falls Heben/Senken des Segels 1 in einer klassischen Manier gewünscht wird.
11. Segelkonstruktion nach Anspruch 5, **dadurch gekennzeichnet**, dass, falls das Segel 1 unter Verwendung eines Seils 4.3 gehoben/gesenkt wird, welches endlos ist und an einer Seite am Halter (1.1) befestigt ist, wobei es an der anderen Seite am Schaft (4.1)
10 befestigt ist, durch das Flaschenzug-System läuft, Getriebe zum Bedienen des Schafte (4.1) eingesetzt werden können, welche nicht selbstverriegelnd sind und keine integrierte Bremse besitzen, wobei ebenfalls selbstverriegelnde Getriebe und Getriebe mit einer integrierten Bremse oder eine Kombination beider Elemente ebenfalls eingesetzt werden können.
12. Segelkonstruktion nach Anspruch 2, **dadurch gekennzeichnet**, dass die Segelstützen (2) am Wasserfahrzeug (P) an dem unteren Abschnitt im Punkt (PP) über eine Abschnittsverbindung (7) geklemmt sind.
15
13. Segelkonstruktion nach Anspruch 1 und 2, **dadurch gekennzeichnet**, dass die Segelstützen (2) ebenfalls eine eingebaute Abschnittsverbindung (7) am ungefähren
20 Mittelpunkt der Länge der Segelstützen (2) besitzen können.
14. Segelkonstruktion nach Anspruch 13, **dadurch gekennzeichnet**, dass die oberen Befestigungselemente der Streben (5) und (6) an den Segelstützen (2) genau unter der Abschnittsverbindung (7) montiert sind, welche am ungefähren Mittelpunkt der Länge der Segelstützen (2) montiert ist.
15. Segelkonstruktion nach Anspruch 12 und 13, **dadurch gekennzeichnet**, dass die Abschnittsverbindungen (7) in ausgestellter oder geschlossener Position einen selbstverriegelnden Mechanismus an einer Seite haben können, so dass die Oberflächen (7.2) und (7.3) aufeinander passen, wobei im Zuge des Öffnens der Abschnittsverbindung (7) der obere Teil der Segelstütze (2) um den Stift (7.1) der Abschnittsverbindung (7) bis
30 zum optionalen Winkel dreht, welcher von 0 bis maximal 180 Winkelgrad reichen kann.
16. Segelkonstruktion nach Anspruch 15, **dadurch gekennzeichnet**, dass die Achsen (7.1) der Abschnittsverbindungen (7) parallel verlaufen, wobei sie gleichzeitig rechtwinklig in der Stapelrichtung SZ der Segelstützen (2) verlaufen.
17. Segelkonstruktion nach Anspruch 11 und 12, **dadurch gekennzeichnet**, dass
35 Achsen (7.1) in Abschnittsverbindungen (7) eine lose Passung in einem Bereich von 0,5 bis 5 mm besitzen und dass diese folglich Torsionsdrehung in der Achse der Segelstützen (2) ermöglichen, die von 3 bis 30 Winkelgrad reichen kann.
18. Segelkonstruktion nach Anspruch 11, **dadurch gekennzeichnet**, dass, wenn nur eine einzige Abschnittsverbindung (7) am unteren Teil der Segelstützen (2) am Deck des

Wasserfahrzeugs (P) installiert ist, der Stift (7.1) der Abschnittsverbindung (7) so auszurichten ist, dass er näher am Heck (K) des Wasserfahrzeugs ist, wobei er gleichzeitig rechtwinklig zur Symmetrieachse des Wasserfahrzeugs (P) ist.

19. Segelkonstruktion nach Anspruch 16, **dadurch gekennzeichnet**, dass, wenn eine
5 oder die erste Abschnittsverbindung (7) an jeder Segelstütze (2) am unteren Teil des Decks des Wasserfahrzeugs (P) montiert ist, und eine andere Abschnittsverbindung (7), welche an der ungefähren Hälfte der Länge der Segelstütze (2) befindlich ist, die Abschnittsverbindungen (7) so ausgerichtet sind, dass die Stifte (7.1) der unteren
10 Abschnittsverbindungen (7) näher am Bug (PP) des Wasserfahrzeugs (P) sind, wobei die Stifte (7.1) der oberen Abschnittsverbindungen (7) näher am Heck (K) des Wasserfahrzeugs (P) sind, und alle Stifte parallel zueinander sind und rechtwinklig zur Symmetrieachse des Wasserfahrzeugs (P) sind.

20. Segelkonstruktion nach Anspruch 6, **dadurch gekennzeichnet**, dass der Halter (4)
15 schwenkbar am Deck des Wasserfahrzeugs (P) durch den Drehpunkt (OK) montiert ist, welcher an einem ungefähren Drittel der Länge der unteren Tragflächentiefe (1) befindlich ist.

21. Segelkonstruktion nach Anspruch 20, **dadurch gekennzeichnet**, dass der
20 Drehpunkt (OK) die Kräfte, welche das Segel (1) vorspannen und die aerodynamischen Windkraftkomponenten, welche auf das Segel (1) einwirken, über den Halter (4) auf das Wasserfahrzeug (P) überträgt.

22. Segelkonstruktion nach Anspruch 21, **dadurch gekennzeichnet**, dass der Halter
(4) um die Achse (OK) in die Richtung (VOK) mit der Seilanordnung gesteuert werden kann, welche um das sogenannte Flaschenzug-System gewunden ist, mit welchem es am Deck des Wasserfahrzeugs (P) befestigt ist.

23. Segelkonstruktion nach Anspruch 21, **dadurch gekennzeichnet**, dass der Halter
25 (4) ebenso um die Achse (OK) in die Richtung (VOK) unter Verwendung eines selbstverriegelnden Getriebes gesteuert werden kann, welches von Hand oder elektrisch, oder unter Verwendung einer anderen Servoantriebs betrieben werden kann.

24. Segelkonstruktion nach Anspruch 23, **dadurch gekennzeichnet**, dass der Halter
30 (4) ebenso um die Achse (OK) in die Richtung (VOK) unter Verwendung eines Getriebes mit einem integrierten Motor gesteuert werden kann, welcher mit dem Autopiloten (AP) des Wasserfahrzeugs (P) verbunden ist.

25. Segelkonstruktion nach Anspruch 23, **dadurch gekennzeichnet**, dass der Halter
35 (4) an der Steuerachse (OK) fixiert ist, so dass er frei oder mit einem Drehmoment von bis zu 50 Nm quer zur Längsachse in die Richtung (SVOK) innerhalb eines Bereichs von 25 bis +25 Winkelgrad kippen kann.

26. Segelkonstruktion nach Anspruch 1 und 2, **dadurch gekennzeichnet**, dass
Tragflächen (2.1), welche um die Längsachsen der Segelstützen (2) frei beweglich sind,

an den Segelstützen (2) montiert werden können, wodurch das freie Spiel zwischen den Segelstützen (2) und den Tragflächen (2.1) zwischen 0,5 bis 15 mm betragen kann.

27. Segelkonstruktion nach Anspruch 26, **dadurch gekennzeichnet**, dass Rotationen (VP) der Tragfläche (2.1) um die Achse der Segelstützen (2) unter Verwendung von
5 bekannten Systemen, welche mit dem Autopiloten (AP) des Wasserfahrzeugs (P) verbunden sind, gesteuert werden können.

28. Segelkonstruktion nach Anspruch 1, 2 und 8, **dadurch gekennzeichnet**, dass man ein Segel (1) zwischen dem Halter (1.1) und dem Halter (4) einklemmen kann, welches bis zu 10 eingebaute Stangen (1.2) pro Laufmeter Höhe des Segels (1) besitzt, wobei die
10 Stangen (1) in Längsrichtung als Segel-Tragflächen (1) konstruiert sind in der Weise, dass sie gemeinsam mit dem Segel (1) eine ideale Tragfläche des Segels (1) bilden, und das Segel (1) gemeinsam mit den installierten Stangen (1.2) unter Verwendung des Schafts (4.1) in den Halter (4) aufgerollt werden kann.

29. Segelkonstruktion nach Anspruch 28, **dadurch gekennzeichnet**, dass ein
15 sogenanntes selbstaufblasbares Segel (1 SN) zwischen dem Halter (1) und dem Halter (4) mit eingewähten Anschlüssen (PJ) eingeklemmt werden kann, welche offene Taschen bilden, welche aufgrund des Windstroms (SV) eine Tragfläche des selbstaufblasbaren Segels (1 SN) schaffen.

30. Segelkonstruktion nach Anspruch 28, **dadurch gekennzeichnet**, dass ein
20 sogenanntes aufblasbares Segel (1 TN) zwischen dem Halter (1) und dem Halter (4) eingeklemmt werden kann, welches aus Kammern besteht oder in anderen Worten zwischen beiden Schichten, wenn in Längsrichtung der Tragflächen des Segels (1 TN) betrachtet, eingebaute Anschlüsse (PJ) beider Schichten beinhaltet, welche die Form der Tragflächen des Segels (1 TN) entlang der gesamten Länge des Segels (1 TN) definieren,
25 wobei der Überdruck in dem aufblasbaren Segel (1 TN) unter Verwendung einer manuell oder elektrisch betriebenen Pumpe oder einer in einer beliebigen anderen Art betriebenen Pumpe erzielt wird.

31. Segelkonstruktion nach Anspruch 30, **dadurch gekennzeichnet**, dass der einzige aufblasbare Teil des aufblasbaren Segels (1 TN) die Vorderkante, das heißt, die
30 Einfallkante (VR) des Segels (1 TN), sein kann.

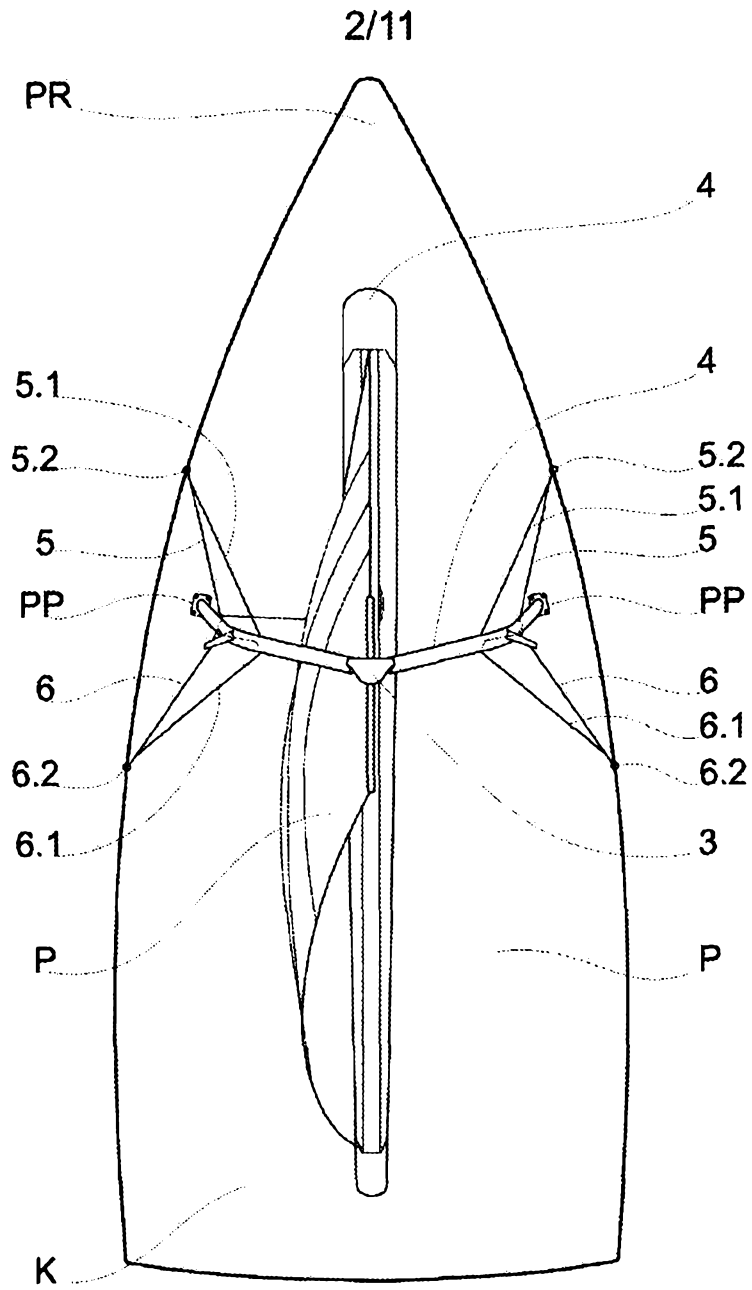

Figure 2

3/11

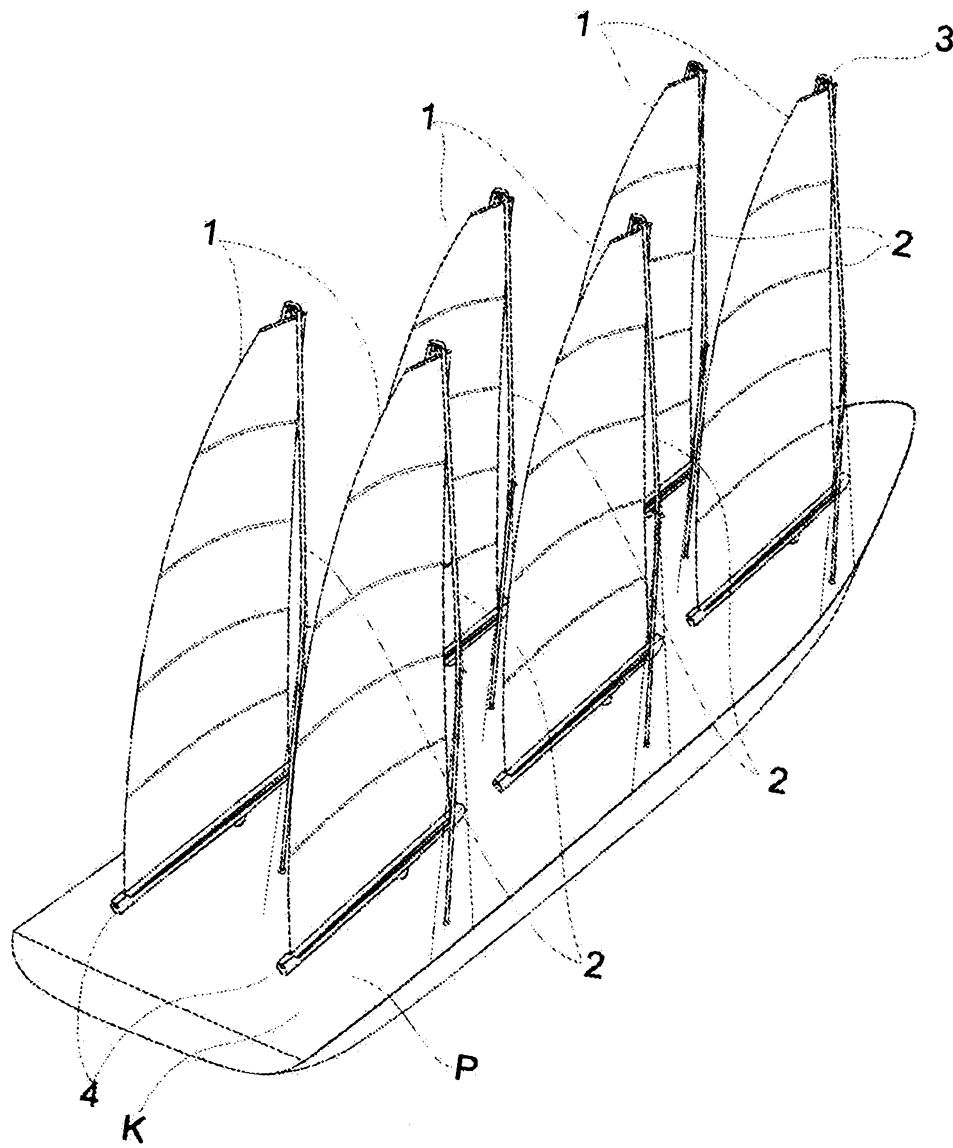
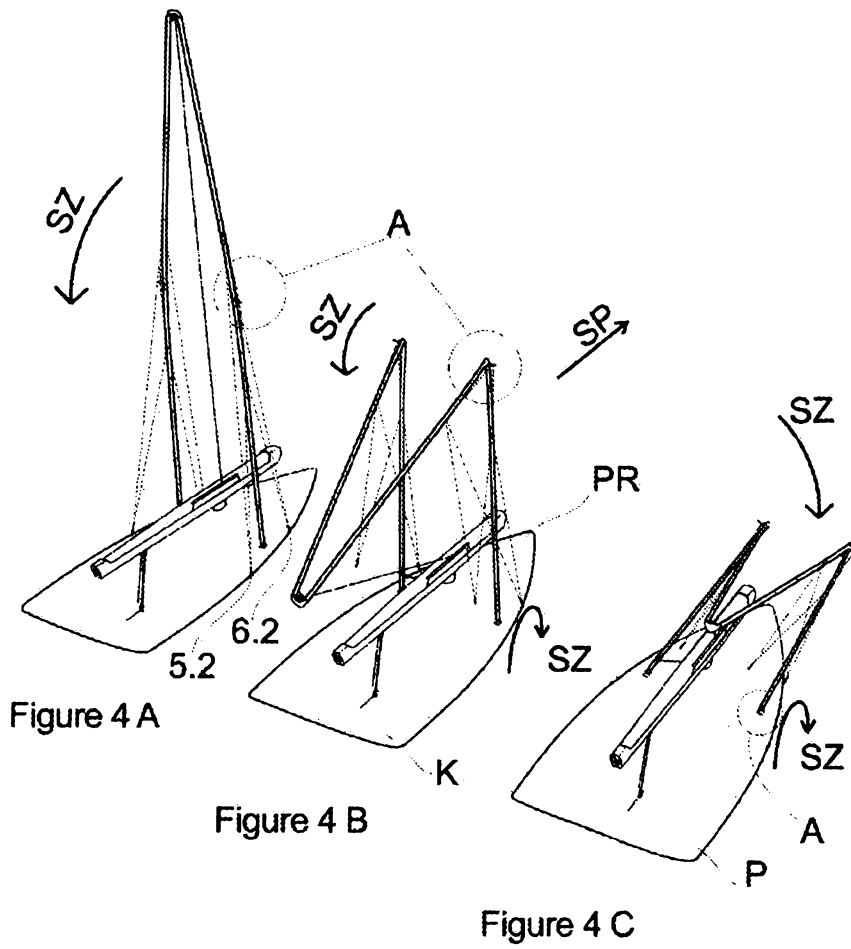

Figure 3



5/11

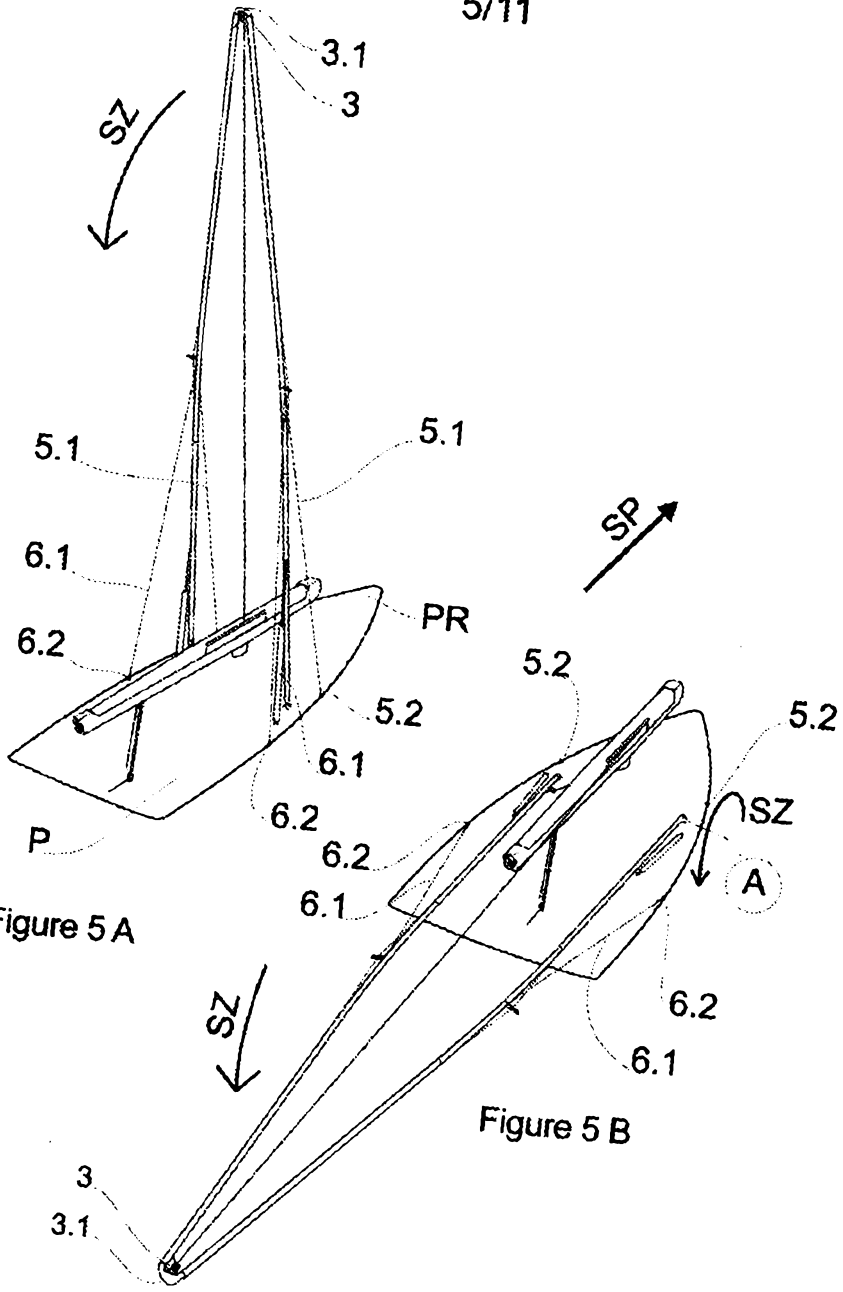

Figure 5 A

Figure 5 B

detail A:

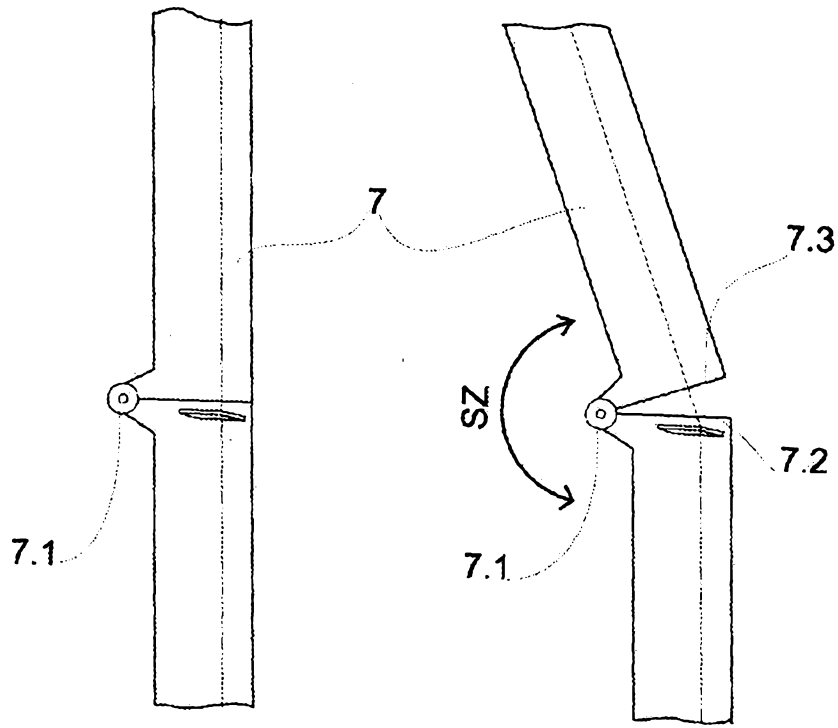
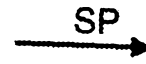

Figure 6 A

Figure 6 B

7/11

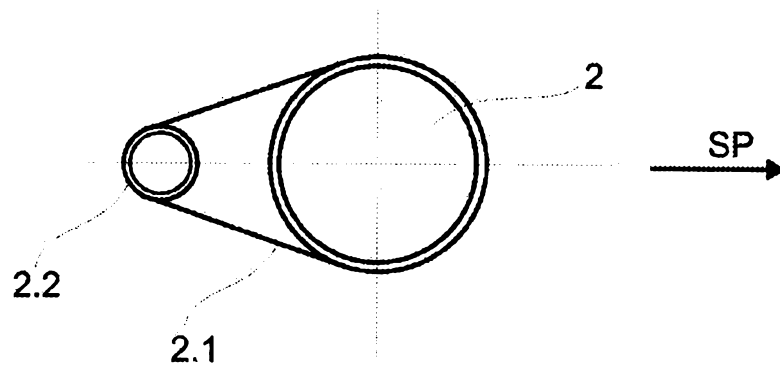

Figure 7 A

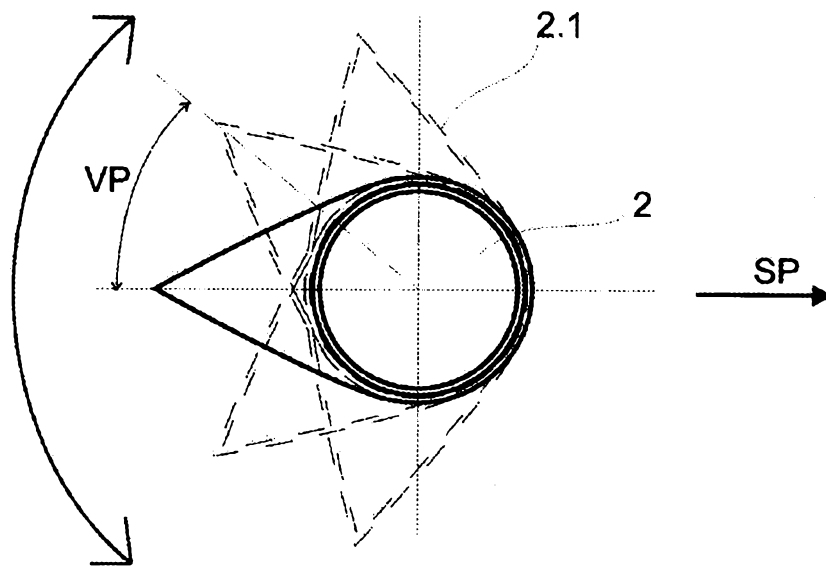

Figure 7 B

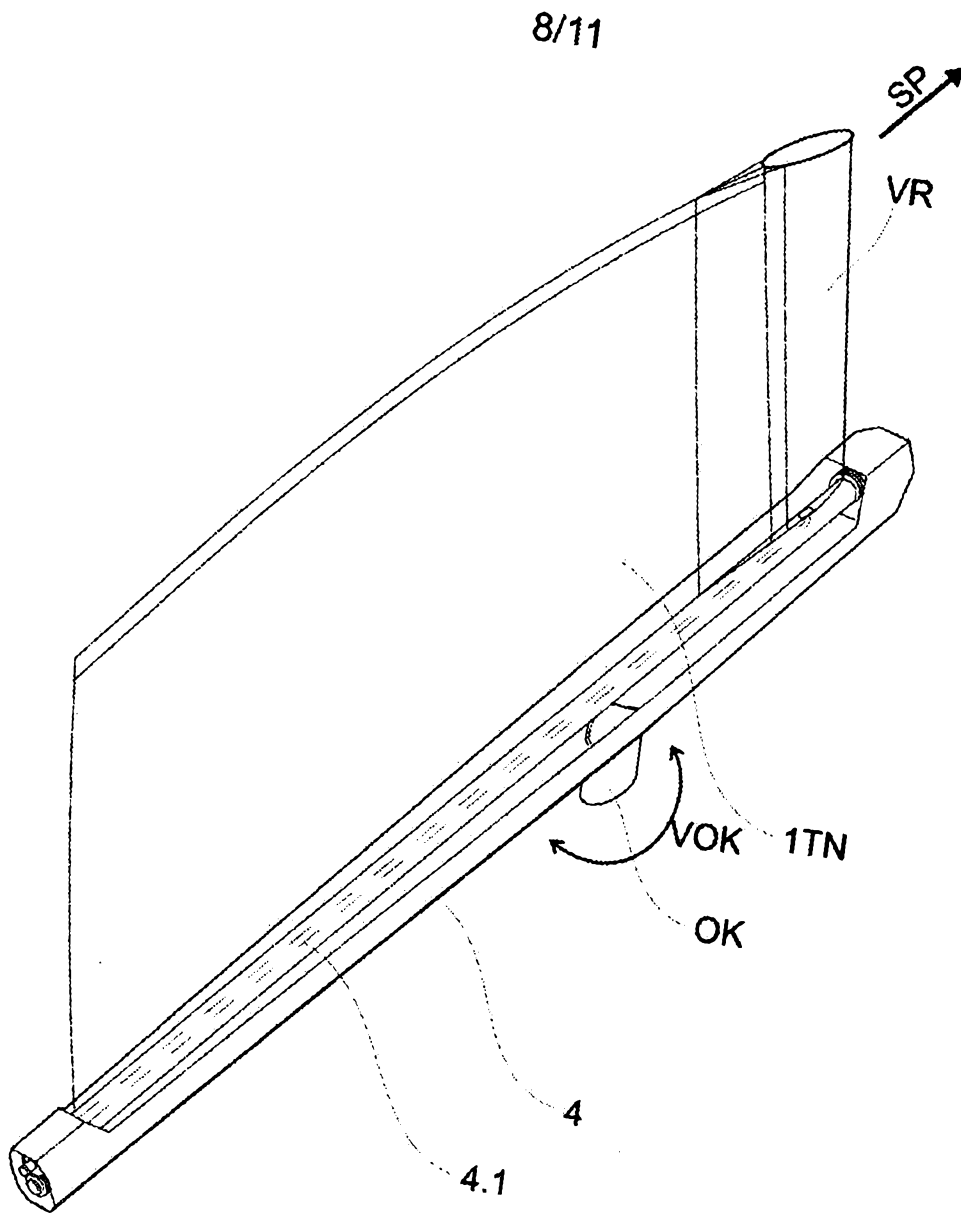

Figure 8

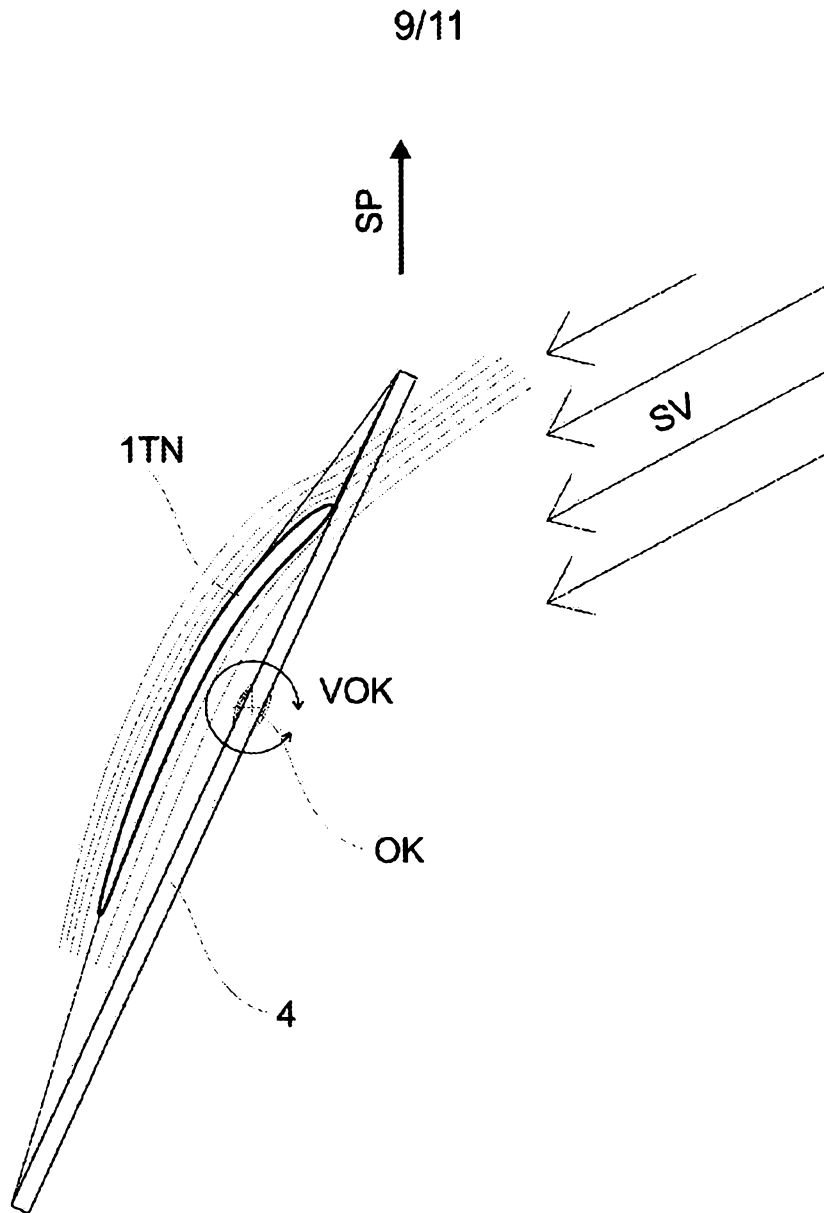

Figure 9

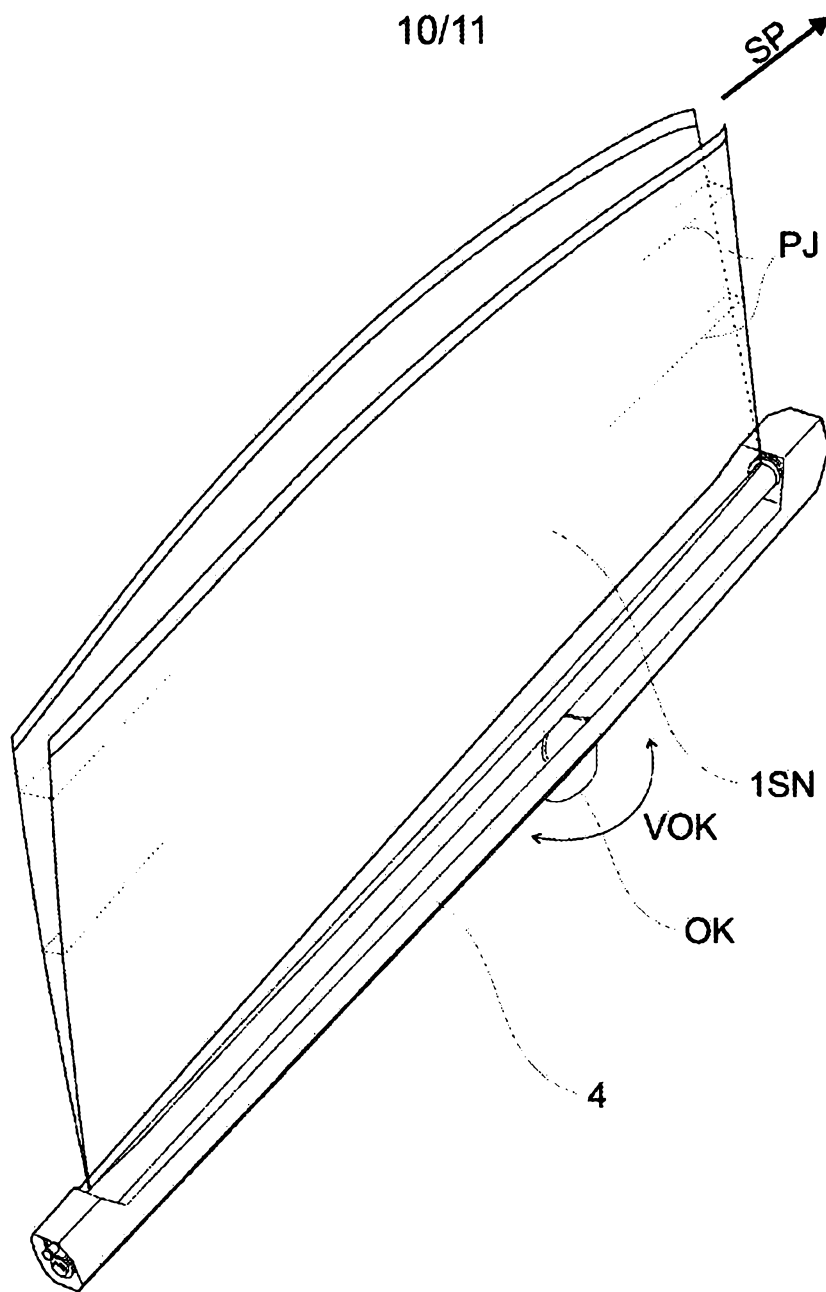

Figure 10

11/11

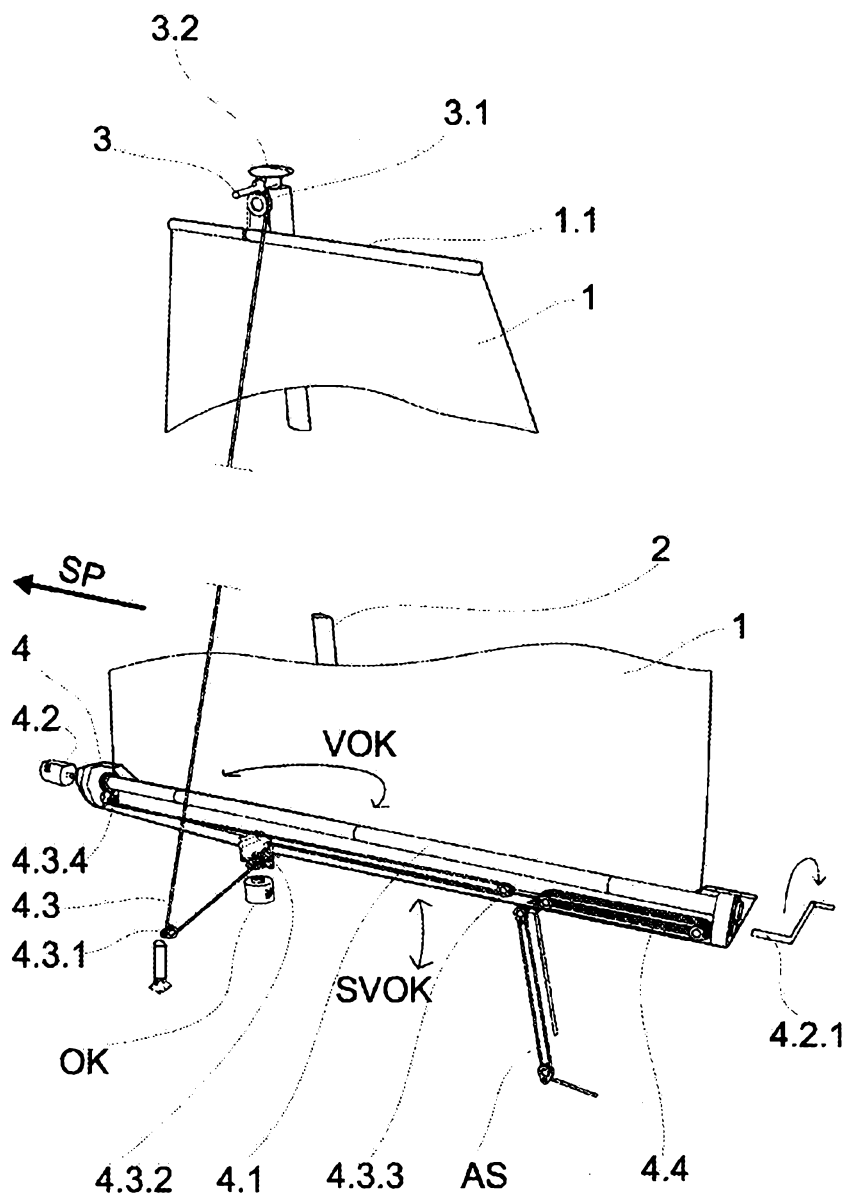

Figure 11

Sail construction comprising foldable sail supports (2), a crossbeam (3), a holder (1.1), a sail (1), a bottom holder (4), ropes (4.3) and a bolt and a tackle system. The sail can be a self-inflatable sail (1 SN) designed similarly to paragliders, partially or fully inflatable.

PATENT COOPERATION TREATY

PCT

INTERNATIONAL SEARCH REPORT

(PCT Article 18 and Rules 43 and 44)

Applicant's or agent's file reference 0860-PCT2-18	FOR FURTHER ACTION see Form PCT/ISA/220 as well as, where applicable, item 5 below.	
International application No. PCT/B2018/050470	International filing date (day/month/year) 25 January 2018 (25-01-2018)	(Earliest) Priority Date (day/month/year) 8 June 2017 (08-06-2017)
Applicant MIDES DESIGN D O O		

This international search report has been prepared by this International Searching Authority and is transmitted to the applicant according to Article 18. A copy is being transmitted to the International Bureau.

This international search report consists of a total of 5 sheets.

It is also accompanied by a copy of each prior art document cited in this report.

1. Basis of the report

a. With regard to the **language**, the international search was carried out on the basis of:

- the international application in the language in which it was filed
 a translation of the international application into _____, which is the language of a translation furnished for the purposes of international search (Rules 12.3(a) and 23.1(b))

b. This international search report has been established taking into account the **rectification of an obvious mistake** authorized by or notified to this Authority under Rule 91 (Rule 43.6**bis**(a)).

c. With regard to any **nucleotide and/or amino acid sequence** disclosed in the international application, see Box No. I.

2. **Certain claims were found unsearchable** (See Box No. II)

3. **Unity of invention is lacking** (see Box No III)

4. With regard to the **title**,

- the text is approved as submitted by the applicant
 the text has been established by this Authority to read as follows:

5. With regard to the **abstract**,

- the text is approved as submitted by the applicant
 the text has been established, according to Rule 38.2, by this Authority as it appears in Box No. IV. The applicant may, within one month from the date of mailing of this international search report, submit comments to this Authority

6. With regard to the **drawings**,

- a. the figure of the **drawings** to be published with the abstract is Figure No. 1
 as suggested by the applicant
 as selected by this Authority, because the applicant failed to suggest a figure
 as selected by this Authority, because this figure better characterizes the invention
- b. none of the figures is to be published with the abstract

Box No. IV Text of the abstract (Continuation of item 5 of the first sheet)

Sail construction comprising foldable sail supports (2), a crossbeam (3), a holder (1.1), a sail (1), a bottom holder (4), ropes (4.3) and a bolt and tackle system. The sail can be a self-inflatable sail (1 SN) designed similarly to paragliders, partially or fully inflatable.

INTERNATIONAL SEARCH REPORT

International application No
PCT/IB2018/050470

A. CLASSIFICATION OF SUBJECT MATTER
INV. B63B15/00
ADD.
According to International Patent Classification (IPC) or to both national classification and IPC

B. FIELDS SEARCHED
Minimum documentation searched (classification system followed by classification symbols)
B63B B63H
Documentation searched other than minimum documentation to the extent that such documents are included in the fields searched

Electronic data base consulted during the international search (name of data base and, where practicable, search terms used)
EPO-Internal, WPI Data

C. DOCUMENTS CONSIDERED TO BE RELEVANT

Category*	Citation of document, with indication, where appropriate, of the relevant passages	Relevant to claim No.
X	US 6 116 177 A (CONANT CARSON V [US]) 12 September 2000 (2000-09-12) column 6 - column 12; figures -----	1-4,6, 12-14, 20-24
X	NL 1 033 753 C2 (TADEMA CORNELIS [NL]) 30 October 2007 (2007-10-30) page 6 - page 11; figures -----	1,2, 12-15, 20,21 15-19
Y	EP 0 636 541 A1 (BENZE THEODORE A [US]) 1 February 1995 (1995-02-01) page 7 - page 11; figures -----	1-12, 20-27 28-31
Y	US 2008/156242 A1 (KNISELY CHARLES W [US] ET AL) 3 July 2008 (2008-07-03) abstract; figures -----	15-19
	----- -/--	

Further documents are listed in the continuation of Box C. See patent family annex.

* Special categories of cited documents :

A document defining the general state of the art which is not considered to be of particular relevance	*T* later document published after the international filing date or priority date and not in conflict with the application but cited to understand the principle or theory underlying the invention
E earlier application or patent but published on or after the international filing date	*X* document of particular relevance; the claimed invention cannot be considered novel or cannot be considered to involve an inventive step when the document is taken alone
L document which may throw doubts on priority claim(s) or which is cited to establish the publication date of another citation or other special reason (as specified)	*Y* document of particular relevance; the claimed invention cannot be considered to involve an inventive step when the document is combined with one or more other such documents, such combination being obvious to a person skilled in the art
O document referring to an oral disclosure, use, exhibition or other means	
P document published prior to the international filing date but later than the priority date claimed	*&* document member of the same patent family

Date of the actual completion of the international search 19 April 2018	Date of mailing of the international search report 16/05/2018
--	--

Name and mailing address of the ISA/ European Patent Office, P.B. 5818 Patentlaan 2 NL - 2280 HV Rijswijk Tel. (+31-70) 340-2040, Fax: (+31-70) 340-3016	Authorized officer Popescu, Alexandru
--	--

INTERNATIONAL SEARCH REPORT

International application No

PCT/IB2018/050470

C(Continuation). DOCUMENTS CONSIDERED TO BE RELEVANT		
Category*	Citation of document, with indication, where appropriate, of the relevant passages	Relevant to claim No.
Y	NL 9 400 478 A (RONDAL BV) 16 March 1995 (1995-03-16) page 4 - page 6; figures -----	28
Y	GB 2 030 945 A (FARROW R) 16 April 1980 (1980-04-16) abstract; figures -----	29-31

INTERNATIONAL SEARCH REPORT

Information on patent family members

International application No

PCT/IB2018/050470

Patent document cited in search report	Publication date	Patent family member(s)	Publication date
US 6116177	A	12-09-2000	NONE

NL 1033753	C2	30-10-2007	NONE

EP 0636541	A1	01-02-1995	AU 678021 B2 15-05-1997
			CA 2128440 A1 28-01-1995
			EP 0636541 A1 01-02-1995
			US 5423274 A 13-06-1995

US 2008156242	A1	03-07-2008	NONE

NL 9400478	A	16-03-1995	NONE

GB 2030945	A	16-04-1980	NONE

PATENT COOPERATION TREATY

From the
INTERNATIONAL SEARCHING AUTHORITY

To: see form PCT/ISA/220

PCT

WRITTEN OPINION OF THE
INTERNATIONAL SEARCHING AUTHORITY
(PCT Rule 43*bis*.1)

Date of mailing (day/month/year) see form PCT/ISA/210 (second sheet)

Applicant's or agent's file reference see form PCT/ISA/220	FOR FURTHER ACTION See paragraph 2 below
---	--

International application No. PCT/B2018/050470	International filing date (day/month/year) 25.01.2018	Priority date (day/month/year) 08.06.2017
---	--	--

International Patent Classification (IPC) or both national classification and IPC INV. B63B15/00

Applicant MIDES DESIGN D O O

1. This opinion contains indications relating to the following items:



- Box No. I Basis of the opinion
- Box No. II Priority
- Box No. III Non-establishment of opinion with regard to novelty, inventive step and industrial applicability
- Box No. IV Lack of unity of invention
- Box No. V Reasoned statement under Rule 43*bis*.1(a)(i) with regard to novelty, inventive step and industrial applicability; citations and explanations supporting such statement
- Box No. VI Certain documents cited
- Box No. VII Certain defects in the international application
- Box No. VIII Certain observations on the international application

2. **FURTHER ACTION**

If a demand for international preliminary examination is made, this opinion will usually be considered to be a written opinion of the International Preliminary Examining Authority ("IPEA") except that this does not apply where the applicant chooses an Authority other than this one to be the IPEA and the chosen IPEA has notified the International Bureau under Rule 66.1*bis*(b) that written opinions of this International Searching Authority will not be so considered.

If this opinion is, as provided above, considered to be a written opinion of the IPEA, the applicant is invited to submit to the IPEA a written reply together, where appropriate, with amendments, before the expiration of 3 months from the date of mailing of Form PCT/ISA/220 or before the expiration of 22 months from the priority date, whichever expires later.

For further options, see Form PCT/ISA/220.

Name and mailing address of the ISA:  European Patent Office P.B. 5818 Patentlaan 2 NL-2280 HV Rijswijk - Pays Bas Tel. +31 70 340 - 2040 Fax: +31 70 340 - 3016	Date of completion of this opinion see form PCT/ISA/210	Authorized Officer Popescu, Alexandru Telephone No. +31 70 340-0 
--	--	--

Box No. 1 Basis of the opinion

1. With regard to the **language**, this opinion has been established on the basis of:
 - the international application in the language in which it was filed.
 - a translation of the international application into , which is the language of a translation furnished for the purposes of international search (Rules 12.3(a) and 23.1 (b)).
2. This opinion has been established taking into account the **rectification of an obvious mistake** authorized by or notified to this Authority under Rule 91 (Rule 43*bis*.1(a))
3. With regard to any **nucleotide and/or amino acid sequence** disclosed in the international application, this opinion has been established on the basis of a sequence listing:
 - a. forming part of the international application as filed:
 - in the form of an Annex C/ST.25 text file.
 - on paper or in the form of an image file.
 - b. furnished together with the international application under PCT Rule 13*ter*.1(a) for the purposes of international search only in the form of an Annex C/ST.25 text file.
 - c. furnished subsequent to the international filing date for the purposes of international search only:
 - in the form of an Annex C/ST.25 text file (Rule 13*ter*.1(a)).
 - on paper or in the form of an image file (Rule 13*ter*.1(b) and Administrative Instructions, Section 713).
4. In addition, in the case that more than one version or copy of a sequence listing has been filed or furnished, the required statements that the information in the subsequent or additional copies is identical to that forming part of the application as filed or does not go beyond the application as filed, as appropriate, were furnished.
5. Additional comments:

Box No. V Reasoned statement under Rule 43bis.1(a)(i) with regard to novelty, inventive step or industrial applicability; citations and explanations supporting such statement

1. Statement

Novelty (N)	Yes: Claims	<u>7-11, 16-19, 25-31</u>
	No: Claims	<u>1-6, 12-15, 20-24</u>
Inventive step (IS)	Yes: Claims	
	No: Claims	<u>1-31</u>
Industrial applicability (IA)	Yes: Claims	<u>1-31</u>
	No: Claims	

2. Citations and explanations

see separate sheet

Box No. VII Certain defects in the international application

The following defects in the form or contents of the international application have been noted:

see separate sheet

Box No. VIII Certain observations on the international application

The following observations on the clarity of the claims, description, and drawings or on the question whether the claims are fully supported by the description, are made:

see separate sheet

Re Item V

Reasoned statement with regard to novelty, inventive step or industrial applicability; citations and explanations supporting such statement

1 Reference is made to the following documents:

- D1 US 6 116 177 A (CONANT CARSON V [US]) 12 September 2000 (2000-09-12)
- D2 NL 1 033 753 C2 (TADEMA CORNELIS [NL]) 30 October 2007 (2007-10-30)
- D3 EP 0 636 541 A1 (BENZE THEODORE A [US]) 1 February 1995 (1995-02-01)
- D4 US 2008/156242 A1 (KNISELY CHARLES W [US] ET AL) 3 July 2008 (2008-07-03)
- D5 NL 9 400 478 A (RONDAL BV) 16 March 1995 (1995-03-16)
- D6 GB 2 030 945 A (FARROW R) 16 April 1980 (1980-04-16)

2 The present application does not meet the criteria of Article 33(2) PCT, because the subject-matter of claim 1 is not new.

The document D1 discloses (the references in parentheses applying to this document, see especially figures 6, 9, 9A to 9D and the description):

a sail construction consisting of the following main elements such as: the foldable sail supports (920b), cross-beam (930), holder (914), sail (900), bottom holder (640), ropes (660, 670) and bolt and tackle system.

Moreover, the documents D2 and D3 disclose all the features of this claim (see the corresponding passages cited in the search report).

3 Dependent claims 2 to 31 do not contain any features which, in combination with the features of any claim to which they refer, meet the requirements of the PCT in respect of novelty and/or inventive step.

The features of these claims are known from documents D1 to D6 (see the corresponding passages cited in the search report) or they are simple technical solutions not involving any inventive activity.

INDUSTRIAL APPLICABILITY:

4 The subject-matter of claims 1 to 31 can be manufactured in industry, and thus looked upon as being industrially applicable.

Re Item VII

5 According to the requirements of Rule 11.13(m) PCT the same feature shall be denoted by the same reference sign throughout the application. This requirement is not met in view of the use of see the claims

- "foldable sail supports (2)" - claim 1, "elastically pre-tensioned sail supports (2)" - claim 2;
- "crossbeam (3)" - claim 1, "connecting coupler (3)" - claim 2;
- "holder (1.1)" and "holder (4)" - claim 5;
- etc.

Re Item VIII

6 The application does not meet the requirements of Article 6 PCT, because the subject-matter of claim 1 is not clear.

It is not clear from the expression "such as" if the features "foldable sail supports (2), cross-beam (3), holder (1.1), sail (1), bottom holder (4), ropes (4.3) and bolt and tackle system" belong to the claimed subject-matter.