

Feb. 22, 1966

B. MAILLARD
FIREARM WITH A SLIDABLE, SLITTED JACKET IN THE
CARTRIDGE CHAMBER HOUSING

3,235,996

Filed May 1, 1963

2 Sheets-Sheet 1

Fig. 1.

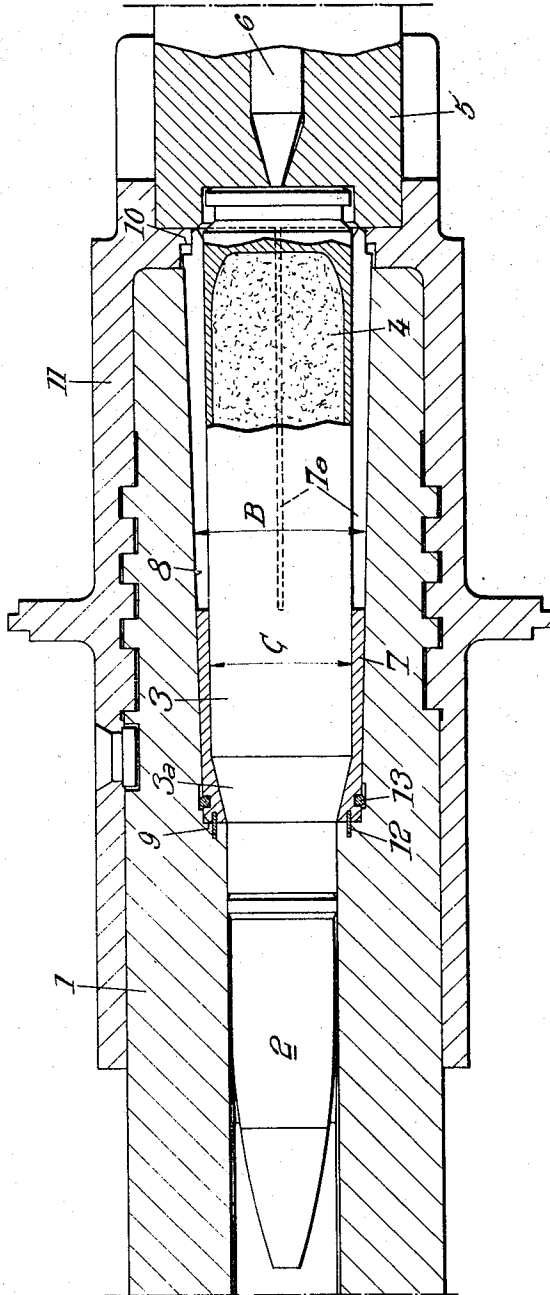

INVENTOR
BERNARD MAILLARD
BY
Larsen and Taylor
ATTORNEYS

Feb. 22, 1966

B. MAILLARD
FIREARM WITH A SLIDABLE, SLITTED JACKET IN THE
CARTRIDGE CHAMBER HOUSING

3,235,996

Filed May 1, 1963

2 Sheets-Sheet 2

Fig. 2.

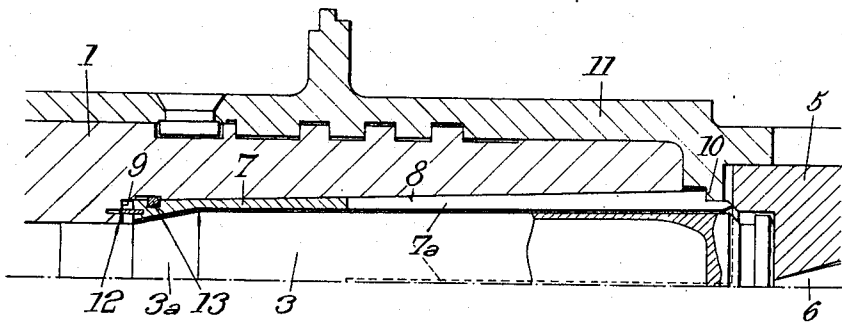

Fig. 3.

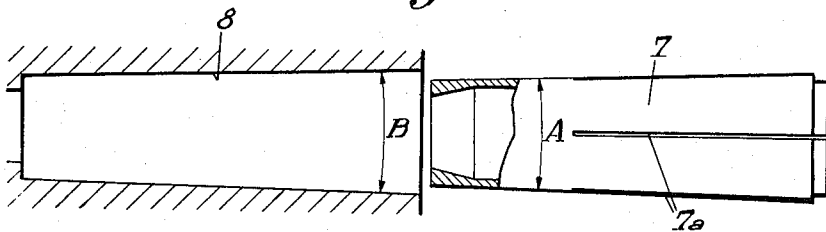
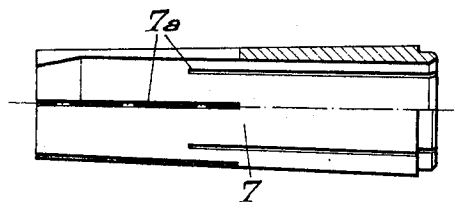

Fig. 4.



INVENTOR
BERNARD MAILLARD
BY *Larson and Jaynes*
ATTORNEYS

1

3,235,996

FIREARM WITH A SLIDABLE, SLITTED JACKET IN THE CARTRIDGE CHAMBER HOUSING

Bernard Maillard, Geneva, Switzerland, assignor to Brevets Aero-Mecaniques S.A., Geneva, Switzerland, a society of Switzerland

Filed May 1, 1963, Ser. No. 277,346

Claims priority, application Luxembourg, May 24, 1962, 41,767

3 Claims. (Cl. 42-76)

The present invention relates to firearms of the type where the ammunition has at least a portion of the propelling charge thereof contained in a cartridge case housed, in firing position, in a cartridge chamber provided for this purpose in the firearm. The invention is more especially, but not exclusively, intended for semi-automatic or automatic firearms and in particular for small caliber automatic firearms, for instance of a caliber ranging from 20 to 50 mm.

The chief object of the present invention is to provide a firearm of this type which is better adapted to meet the requirements of practice, in particular concerning the conditions where extraction of the cartridge case takes place.

The essential feature of the invention consists in constituting the side wall of the cartridge chamber, over at least a portion of its length, in the form of a jacket slidable axially in a housing provided for this purpose in the portion of the firearm where said cartridge chamber is located.

Preferably, according to another feature of the invention, this sliding jacket and its housing are arranged in such manner that the recoil movement of the jacket with respect to its housing permits a radial expansion of the jacket and therefore a release of its grasp on the case of the cartridge which has just been fired, and advantageously, for this purpose, said jacket is given some taper with respect to its housing and has a radial resiliency producing an expansion thereof when it moves from its front position to its rear position.

A preferred embodiment of the present invention will be hereinafter described with reference to the appended drawings, given merely by way of example, and in which:

FIG. 1 is an axial sectional view, with parts cut away, of a portion of a firearm made according to the invention and wherein a cartridge is shown in firing position just at the time when said cartridge is being struck by the firing pin;

FIG. 2 is an axial half section showing the same elements but in the relative positions they occupy during the initial phase of the extraction of the case of the cartridge which has just been fired;

FIG. 3 is an elevational view with parts in section showing, opposite its housing, a jacket belonging to a firearm such as illustrated by FIGS. 1 and 2;

FIG. 4 shows partly in elevational view and partly in axial section a modification of said jacket.

The firearm shown by FIG. 1 includes a cartridge chamber located at the rear of the barrel 1 of the firearm, introduction of a cartridge (comprising a projectile 2 fitted at the end of a cartridge case 3 containing a propelling charge 4) into said cartridge chamber being ensured by the frontward movement of a sliding breechblock 5 containing a firing pin 6 and an extractor (not shown) whereas extraction of cartridge case 3, after firing of the cartridge, is ensured by the rearward displacement of said breechblock 5.

Extraction of an empty cartridge case from the cartridge chamber involves some difficulties due, on the one hand, to the fact that said cartridge case generally undergoes some swelling after the cartridge has been

2

fired, in particular in the rear portion thereof in the case of a conical cartridge case, and, on the other hand, to the fact that firing must take place with an ammunition which is not greased to facilitate its extraction from the cartridge chamber.

In other words, the conditions of operation of an automatic firearm tend to produce, in the absence of special precautions, a wedging of the empty cartridge cases in the cartridge chamber, which wedging is the more important as the residual pressure is higher (case of automatic firearms working at a high firing rate).

The object of the invention is to reduce the above mentioned risks of wedging and therefore practically to eliminate firing incidents inherent in such risks (breaking of the extractor, reduction of the rate of firing and so on).

According to said invention, as illustrated by FIG. 1, the side wall of the cartridge chamber of the firearm consists, over at least a portion of its length, and preferably over the total length of its main portion 3 and of its neck 3a, of a jacket 7 slidable axially in a housing 8 provided for this purpose in the rear portion of the barrel 1 of the firearm.

Preferably, two fixed abutments are provided for limiting the relative displacement of jacket 7 in housing 8 and for determining the front and rear positions thereof. The front abutment consists, in the example shown, of a shoulder 9 located at the point where the wall of barrel 1 is connected with the housing 8 provided for jacket 7. The rear abutment consists of an inward flange 10 carried by a hoop 11 surrounding the rear portion of said barrel 1.

It will be understood that, owing to the fact that the wall of the housing 8 of jacket 7 is not exposed to the direct action of propelling gases, it will be possible to lubricate said wall with a suitable grease such for instance as molybdenum bisulfite, thus facilitating the recoil movement of said jacket 7. This movement may be further facilitated by making said jacket 7 of a material, such for instance as tempered and reheated spring steel, of nitrided steel, possibly covered with an anti-friction coating, having, with respect to the material of which barrel 1 is made, a friction coefficient substantially lower than those of the materials generally used for making cartridge cases 3 (copper, steel, brass and so on) and to that of the protection varnish which generally protects them.

Thus, immediately after a shot is fired and if it is supposed that cartridge case 3 has swelled and is wedged in jacket 7, the whole of said cartridge case and said jacket can easily slide back in housing 8 due to the fact that the friction between the wall of housing 8 and jacket 7 is much lower than that existing between said jacket and cartridge case 3.

The recoil displacement of jacket 7, which is actually only of some millimeters, thus permits the starting and acceleration of the rearward movement of breechblock 5 which has been previously released so that, when jacket 7 reaches its limit end position, breechblock 5 already has a considerable living force which enables it to extract cartridge case 3 easily from jacket 7.

It will thus be seen that, even if the intensity of wedging of cartridge case 3 in jacket 7 is not modified during the recoil stroke of this jacket, which would be the case in particular if the outer wall of jacket 7 and the inner wall of housing 8 were cylindrical and remained in tight contact with each other, extraction of cartridge case 3 is greatly facilitated by the fact that the rearward displacement of breechblock 5 starts without a substantial resistance.

3

This effect may be used alone but it is preferable, according to another feature of the invention which will now be described, to take advantage of the recoil movement of jacket 7 to release the grasp exerted by said jacket on the cartridge case 3 located therein.

For this purpose, jacket 7 and its housing 8 are arranged in such manner that said jacket has some taper with respect to said housing, this result being obtained, in the embodiment shown by the drawing, by giving the outer wall of jacket 7 and the inner wall of housing 8 the shape of a frustum of a cone having its apex toward the front.

Furthermore, jacket 7 is given a radial resiliency causing it to expand, also radially, when said jacket 7 passes from its front position illustrated by FIG. 1 (where it must keep cartridge case 3 in position without exerting any substantial radial stress thereon before firing) to its rear position, shown by FIG. 2 (where the release of the grasp exerted by jacket 7 on cartridge case 3 when the shot has been fired due to the swelling of said cartridge case has been exaggerated).

The radial resiliency of jacket 7 may be obtained for instance by giving said jacket and its housing 8 a dimension such that said jacket undergoes an internal stress when it is fully engaged in the frontward direction in its housing.

It is also possible, as shown by the drawing, to provide, in the wall of jacket 7 longitudinally slits 7_a so as to give said jacket a radial resiliency. Said slits 7_a extend over at least the rear portion of jacket 7, said jacket and its housing 8 being dimensioned in such manner that the engagement of jacket 7 frontwardly in its housing 8 produces a resilient constriction effect on said jacket. This effect may produce for instance, for a caliber of 20 mm. a main reduction of diameter of the jacket averaging one tenth of a millimeter.

In order to obtain such a resiliency effect of jacket 7 in its housing 8, it suffices, as shown by FIG. 3, to give the apex angle A of the frusto-conical external wall of said jacket supposed to be free from any radial action, a value greater than that of the apex angle B of the internal wall, also of frusto-conical shape, of housing 8.

It should be noted that when the cartridge case 3 is of frusto-conical shape, which is generally the case, the apex angle B of jacket 7 will be preferably greater than the apex angle C of said cartridge case.

Advantageously, the mounting of jacket 7 in its housing 8 further comprises, at the front, a packing annular member 12, in the form of a cylindrical ring, fitting, whatever be the axial position of jacket 7, in two circular grooves located opposite each other, respectively in shoulder 9 and in the front edge of jacket 7.

Furthermore, there is provided a holding member 13, for instance of steel, capable of preventing jacket 7 from leaving its housing when the firearm is taken to pieces (barrel 1 disengaged from hooping member 11 which carries the rear abutment 10).

From the preceding description it results that, once cartridge case 3 has been extracted from jacket 7, the latter is in rear position and the return of said jacket into front position is ensured by a fresh cartridge introduced into the firearm and by breechblock 5 during its frontward movement, which introduces said fresh cartridge into said jacket.

The strain imposed on the front edge of jacket 7 when it comes into contact with the front abutment 9 may be reduced by giving the inner wall of said jacket, at the front thereof, a frusto-conical shape corresponding sub-

4

stantially to the frusto-conical shape of the neck 3_a of the cartridge case but having however an apex angle slightly smaller than the apex angle of said cartridge case neck. Thus this neck first comes into contact with the base of the frusto-conical portion of the inner wall of the jacket and then applies gradually, by its deformation, against the wall of said frusto-conical portion.

The arrangement according to the present invention permits of ensuring extraction of empty cartridge cases in a much easier manner, the improvement making it possible to use, without risk of wedging, a cartridge having a cylindrical case. In this case, it will be preferable to make jacket 7 radially resilient over its whole length, for instance by providing it, as in the embodiment illustrated by FIG. 4, with two sets of slits 7_a provided in staggered relation to each other, respectively in the front part and in the rear part of said jacket.

The invention has been described in the case of an automatic firearm having an axially movable breechblock but it should be well understood that it could be applied in a similar manner to the case of a firearm having a revolving cylindrical breechblock.

In a general manner, while the above description discloses what is deemed to be a practical and efficient embodiment of the invention, said invention is not limited thereto as there might be changes made in the arrangement, disposition and form of the parts without departing from the principle of the invention as comprehended within the scope of the appended claims.

What I claim is:

1. For use with a cartridge including a cartridge case, a firearm which comprises, in combination, a barrel including, at the rear end thereof, a cartridge chamber housing and a jacket slidable axially to a limited degree in said housing, the outer wall of said jacket and the inner wall of said housing tapering toward the front of said firearm, said two walls fitting against each other when said jacket is in its front limit position in said housing, the rear portion of said jacket being split to ensure an outward radial resiliency thereof so that it can expand radially when moved axially to its rear position with respect to said housing.

2. A firearm according to claim 1 wherein said jacket, in the form of a body of revolution, is provided with longitudinal slits extending from an intermediate portion thereof to the rear edge thereof.

3. A firearm according to claim 1 wherein said jacket, in the form of a body of revolution, is provided with two sets of longitudinal slits extending along generatrices of this body of revolution from intermediate portions of the jacket, respectively, the slits of the first set extending rearwardly to the rear edge of said jacket and the slits of the second set extending frontwardly to the front edge of said jacket, the two sets being disposed in staggered relationship with respect to each other, the front ends of the slits of the first set being nearer to the front edge of said jacket than the rear ends of the slits of the second set.

References Cited by the Examiner

UNITED STATES PATENTS

631,399	8/1899	Gillette	42-77
783,561	2/1905	White	42-77 X
2,847,787	8/1958	Williams	42-76
2,922,242	1/1960	Pachmayr	42-79
2,952,089	9/1960	Maier et al.	42-76
2,992,596	7/1961	Hammer	42-76

BENJAMIN A. BORCHELT, *Primary Examiner.*