

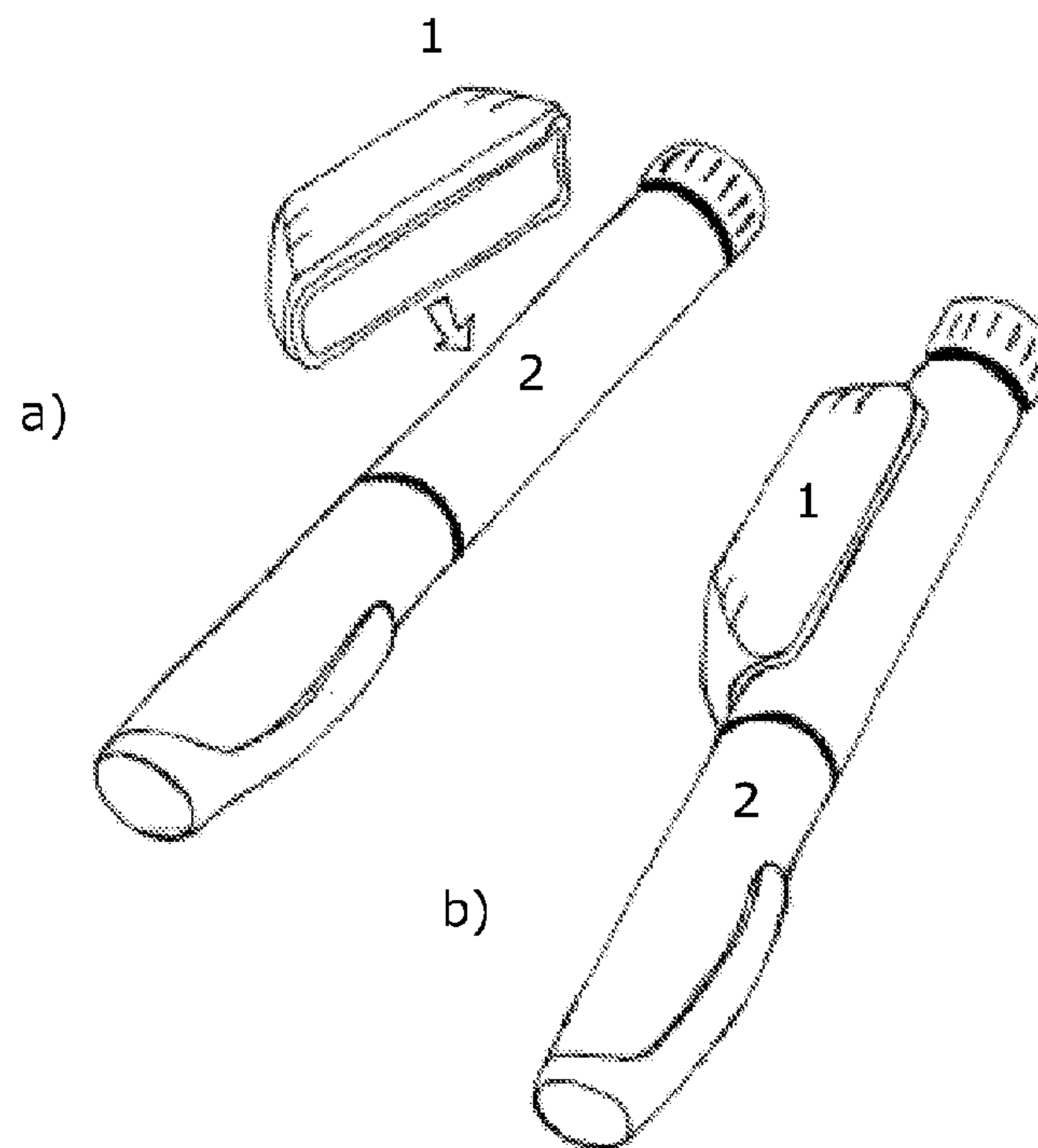

(86) **Date de dépôt PCT/PCT Filing Date:** 2007/03/20
 (87) **Date publication PCT/PCT Publication Date:** 2007/09/27
 (45) **Date de délivrance/Issue Date:** 2014/12/30
 (85) **Entrée phase nationale/National Entry:** 2008/09/12
 (86) **N° demande PCT/PCT Application No.:** EP 2007/052636
 (87) **N° publication PCT/PCT Publication No.:** 2007/107564
 (30) **Priorité/Priority:** 2006/03/20 (EP06005596.9)

(51) **Cl.Int./Int.Cl. A61M 5/315** (2006.01),
G07C 3/00 (2006.01), **G08C 17/00** (2006.01)
 (72) **Inventeur/Inventor:**
LARSEN, ANDRE, DK
 (73) **Propriétaire/Owner:**
NOVO NORDISK A/S, DK
 (74) **Agent:** NORTON ROSE FULBRIGHT CANADA
LLP/S.E.N.C.R.L., S.R.L.

(54) **Titre : MODULE ELECTRONIQUE POUR SYSTEME MECANIQUE DE DELIVRANCE DE MEDICAMENTS**
 (54) **Title: ELECTRONIC MODULE FOR MECHANICAL MEDICATION DELIVERY DEVICES**



(57) **Abrégé/Abstract:**

The present invention relates to a method for monitoring the operation of a medication delivery device. In particular, the present invention relates to a method comprising the steps of arranging an electronic module in the vicinity of the medication delivery device, detecting, using the electronic module, measurable signals generated in response to an action occurring within the associated medication delivery device, and storing, using storage means of the electronic module, information associated with or representing the measured signals. The present invention further relates to an electronic module capable of performing the above-mentioned method.

(12) INTERNATIONAL APPLICATION PUBLISHED UNDER THE PATENT COOPERATION TREATY (PCT)

(19) World Intellectual Property Organization
International Bureau(43) International Publication Date
27 September 2007 (27.09.2007)

PCT

(10) International Publication Number
WO 2007/107564 A1

- (51) International Patent Classification:
G06F 19/00 (2006.01) A61M 5/315 (2006.01)
- (21) International Application Number:
PCT/EP2007/052636
- (22) International Filing Date: 20 March 2007 (20.03.2007)
- (25) Filing Language: English
- (26) Publication Language: English
- (30) Priority Data:
06005596.9 20 March 2006 (20.03.2006) EP
- (71) Applicant (for all designated States except US): **NOVO NORDISK A/S** [DK/DK]; Novo Allé, DK-2880 Bagsværd (DK).
- (72) Inventor; and
- (75) Inventor/Applicant (for US only): **LARSEN, André** [DK/DK]; Skovengen 3, DK-2791 Dragør (DK).
- (74) Agent: **INSPICOS A/S**; Bøge Allé 5, P.O. Box 45, DK-2970 Hørsholm (DK).

- (81) Designated States (unless otherwise indicated, for every kind of national protection available): AE, AG, AL, AM, AT, AU, AZ, BA, BB, BG, BH, BR, BW, BY, BZ, CA, CH, CN, CO, CR, CU, CZ, DE, DK, DM, DZ, EC, EE, EG, ES, FI, GB, GD, GE, GH, GM, GT, HN, HR, HU, ID, IL, IN, IS, JP, KE, KG, KM, KN, KP, KR, KZ, LA, LC, LK, LR, LS, LT, LU, LY, MA, MD, MG, MK, MN, MW, MX, MY, MZ, NA, NG, NI, NO, NZ, OM, PG, PH, PL, PT, RO, RS, RU, SC, SD, SE, SG, SK, SL, SM, SV, SY, TJ, TM, TN, TR, TT, TZ, UA, UG, US, UZ, VC, VN, ZA, ZM, ZW.
- (84) Designated States (unless otherwise indicated, for every kind of regional protection available): ARIPO (BW, GH, GM, KE, LS, MW, MZ, NA, SD, SL, SZ, TZ, UG, ZM, ZW), Eurasian (AM, AZ, BY, KG, KZ, MD, RU, TJ, TM), European (AT, BE, BG, CH, CY, CZ, DE, DK, EE, ES, FI, FR, GB, GR, HU, IE, IS, IT, LT, LU, LV, MC, MT, NL, PL, PT, RO, SE, SI, SK, TR), OAPI (BF, BJ, CF, CG, CI, CM, GA, GN, GQ, GW, ML, MR, NE, SN, TD, TG).

Published:
— with international search report

[Continued on next page]

(54) Title: ELECTRONIC MODULE FOR MECHANICAL MEDICATION DELIVERY DEVICES

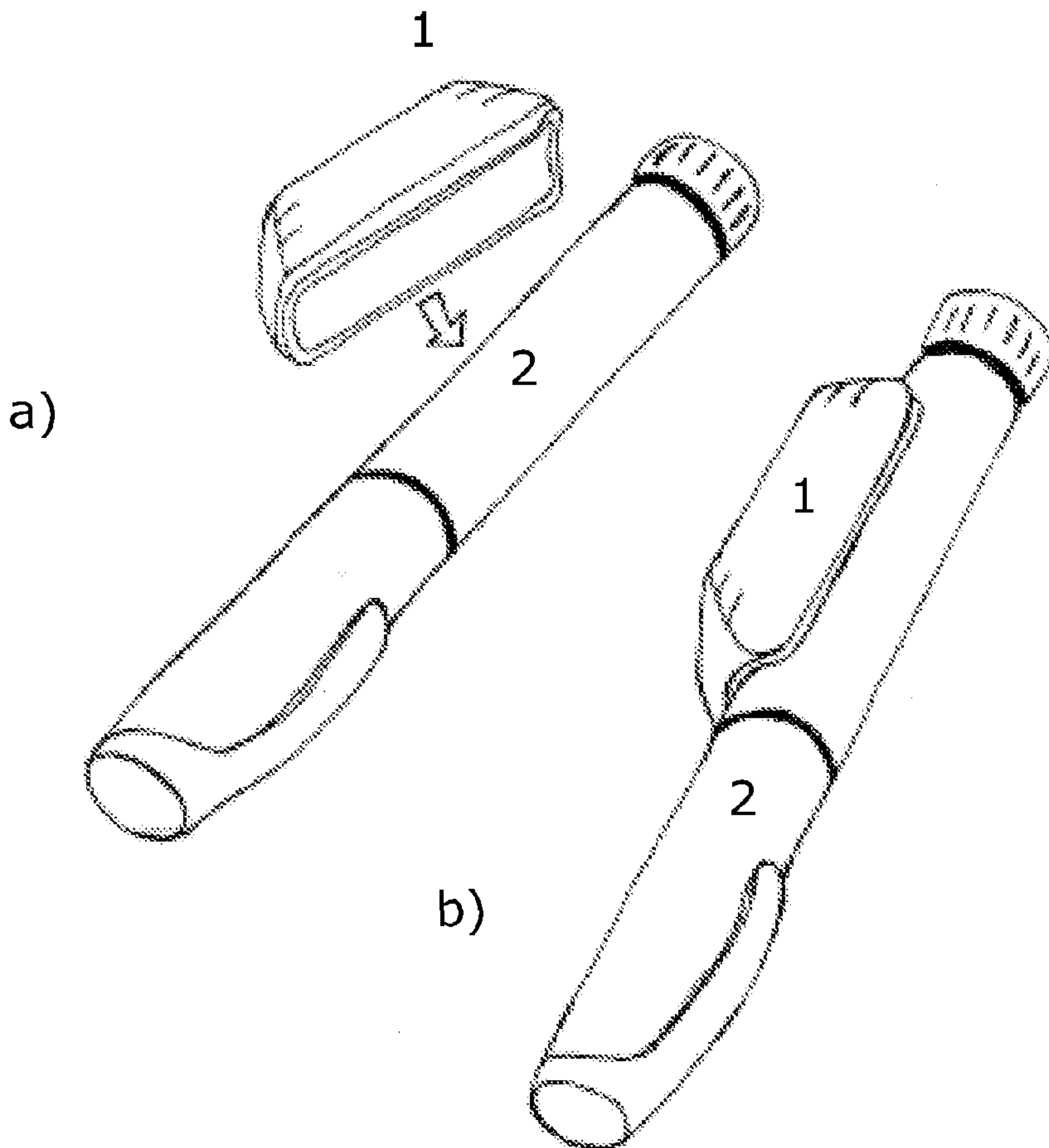

(57) Abstract: The present invention relates to a method for monitoring the operation of a medication delivery device. In particular, the present invention relates to a method comprising the steps of arranging an electronic module in the vicinity of the medication delivery device, detecting, using the electronic module, measurable signals generated in response to an action occurring within the associated medication delivery device, and storing, using storage means of the electronic module, information associated with or representing the measured signals. The present invention further relates to an electronic module capable of performing the above-mentioned method.

WO 2007/107564 A1

WO 2007/107564 A1



— *before the expiration of the time limit for amending the claims and to be republished in the event of receipt of amendments*

For two-letter codes and other abbreviations, refer to the "Guidance Notes on Codes and Abbreviations" appearing at the beginning of each regular issue of the PCT Gazette.

ELECTRONIC MODULE FOR MECHANICAL MEDICATION DELIVERY DEVICES

FIELD OF THE INVENTION

The present invention relates to an electronic module adapted to be positioned on an outer surface of a pen-like medication delivery device. In particular, the present invention relates to an electronic module capable of measuring signals, such as audible, optical, vibration or
5 electromagnetic signal, generated during operation of a pen-like medication delivery device.

BACKGROUND OF THE INVENTION

For the users of medication delivery devices it is a cumbersome process to keep track of the
10 amount of doses being expelled from the medication delivery device. This process is being further complicated if the time of injection, date of injection etc. are also to be monitored.

US 6,482,185 discloses an external display apparatus for pen-like injection devices. For people with an impaired vision, the setting of a dose on a pen-like injection device may be
15 difficult. In US 6,482,185 an external display apparatus is provided. This display apparatus may be attached to the pen. Via contacts and counter contacts information about the dose is transmitted to the display apparatus and shown on a large display. The display apparatus suggested in US 6,482,185 may also comprise some sort of storage arrangement which allows storage or recording of a set dose of medicament together with associated data like
20 time, date and the kind of medicament (e.g. insulin preparation).

It is a disadvantage of the display apparatus suggested in US 6,482,185 that it requires that the pen-like injection device to which it is intended to be attached to undergoes severe modifications in that special communication arrangements, such as electrical contacts, optical
25 ports, gear wheels etc. are required in order to transfer information from the pen-like injection device to the display apparatus.

WO 2004/110528 relates to a device for examination of a medical device. The device suggested in WO 2004/110528 comprises an acoustic receiver which is capable of detecting
30 sounds emitted by the medical device in order to examine the medical device for errors. WO 2004/110528 further relates to a method for examining a medical device whereby sound emitted by the medical device is detected and analysed.

The device suggested in WO 2004/110528 is intended for detecting and localising errors in
35 medical devices. Thus, the device suggested in WO 2004/110528 forms part of a test facility for testing medical devices. The device suggested in WO 2004/110528 is unsuitable for

mapping the manner of use of a medical device, such as a medication delivery device capable of delivering set doses of insulin, over a given period of time. In order to obtain reliable mapping results, such given period of time may for example be several months. The reasons why the device according to WO 2004/110528 is unsuitable for mapping the manner of use of a medical device are many. For example, the device suggested in WO 2004/110528 does not facilitate time stamping of events occurring in a medical device. This lack of time stamping makes it impossible to arrange detected events in a chronological correct order.

It is an object of the present invention to provide a portable electronic module being capable of monitoring the overall operation of standard, and thereby non-modified, medication delivery devices.

It is a further object of the present invention to provide a portable electronic module adapted to be attached to a medication delivery device without influencing or affecting daily use of the medication delivery device.

According to the present invention an electronic module capable of measuring externally accessible acoustical and/or vibrational signals generated under normal operation, such as during setting and expelling of a set dose of medicament, of a pen-like medication delivery device is suggested.

It is an advantage of the present invention that data relating to corresponding values of time/date and the amount of injected medicament may easily be transferred from the electronic module to for example a computer for further processing. In this way, traditional paper-based diary's can be avoided. In addition, the present invention can be used as an electronic logbook for conventional medication delivery devices.

SUMMARY OF THE INVENTION

The above-mentioned object is complied with by providing, in a first aspect, a method for wirelessly monitoring the operation of a mechanical medication delivery device, the method comprising the steps of

- attaching an electronic module to an associated mechanical medication delivery device using mutually cooperating coupling means for releasable coupling the electronic module to the associated mechanical medication delivery device,

- detecting, using the electronic module, measurable signals generated in response to an event or action occurring within the associated medication delivery device, and associating with each event a time stamp, and

5 - storing, using storage means of the electronic module, information associated with the detected measurable signals, and storing the associated time stamp

wherein the measurable signals are acoustical and/or vibrational signals.

Thus, the measurable signal may be acoustical signals generated in response to setting a dose of medicament. The dose of medicament may be set by activation of a dose setting member of the associated mechanical medication delivery device. The acoustical signals may
10 also be generated in response to expelling a dose of medicament from the associated mechanical medication delivery device.

The method may further comprise the step of transmitting information associated with or representing the measured signals to an, in relation to the electronic module, external module, unit or portable device for further processing. The transmitting to the external
15 module, unit or portable device may be provided by wireless means, such as Bluetooth.

By mechanical medication delivery device is meant a handheld device where the user of the device delivers the required force to expel a set dose of medicament. Alternatively, the user of the mechanical medication delivery device may energize the device by accumulating energy in an appropriate member of the mechanical medication delivery device. Such
20 member may include a resilient member, such as a linear spring or a torsion spring.

In a second aspect, the present invention relates to a portable electronic module adapted to be releasable coupled on an associated mechanical medication delivery device, the electronic module comprising

25 - means for wirelessly detecting measurable signals generated in response to an event or action occurring within the associated mechanical medication delivery device, and associating with each event or action a time stamp,

- mutually cooperating coupling means for releasable coupling the electronic module to the associated mechanical medication delivery device, and

- means for storing information associated with the detected measurable signals, and storing the associated time stamp

wherein the measurable signals are acoustical and/or vibrational signals.

5

Again, mechanical medication delivery device is intended to mean a handheld device where the user of the device delivers the required force to expel a set dose of medicament.

Alternatively, the user of the mechanical medication delivery device may energize the device by accumulating energy in an appropriate member of the mechanical medication delivery device. Such member may include a resilient member, such as a linear spring or a torsion spring.

The electronic module may further comprise means for transmitting detected, stored or recorded information to an external module or unit for further processing. The electronic module may in addition comprise signal processor means adapted to process the detected signal or signals prior to storing information associated therewith or representing said signal or signals. The detecting means may comprise a microphone capable of detecting acoustical signals generated in the associated mechanical medication delivery device. Preferably such microphone is a miniature microphone, such as the types of microphones used in the hearing aid industry.

Alternatively or in addition, the detecting means may comprise an accelerometer capable of detecting vibrational signals generated in the associated mechanical medication delivery device.

The transmitting means may comprise means for wirelessly transmitting information from the electronic module to the external module or unit. The wireless transmitting of information from the electronic module to the external module or unit may be provided using Bluetooth.

30

The electronic module may further comprise display means adapted to provide visual information to the user of the electronic module, and a touch pad switch adapted to switch on the electronic module upon activation. Alternatively, contact means adapted to switch on the electronic module during normal use of the medication delivery device may be provided. Such contact means are preferably hidden within the housing of the electronic module.

35

In accordance with another aspect of the present invention, there is provided a method for wirelessly monitoring the operation of a mechanical medication delivery device, the method comprising the steps of:

4a

providing a mechanical medication delivery device for setting an amount of a dose of a medicament and injecting of set doses, said mechanical medication delivery device generating click sounds during setting and/or expelling of a dose of a medicament whereby the number of click sounds correspond to an amount of a set dose and/or an expelled dose;

5 providing a portable electronic module, the electronic module comprising a module housing and detector means mounted in the module housing;

attaching the electronic module to said mechanical medication delivery device using mutually cooperating coupling means for realisably coupling the electronic module to the mechanical medication delivery device;

10 detecting, using the electronic module, click sounds generated in response to an event or action occurring within the associated medication delivery device during the setting and/or expelling of a dose, and associating with each event or action a time stamp; and

storing, using storage means of the electronic module, information associated with the detected click sounds including the number of click sounds detected during the setting and/or expelling of a dose, and storing the associated time stamp.

In accordance with another aspect of the present invention, there is provided a portable electronic module adapted to be releasable attached to an associated mechanical medication delivery device, said mechanical medication delivery device being configured for setting the amount of a dose of a medicament and injecting of set doses, the mechanical medication delivery device generating click sounds during setting and/or expelling of a dose of a medicament whereby the number of click sounds correspond to an amount of a set dose and/or an expelled dose, the electronic module comprising:

25 a module housing;
detector means mounted in the module housing for wirelessly detecting click sounds generated in response to an event or action occurring within the associated mechanical medication delivery device during the setting and/or expelling of a dose, and associating with each event or action a time stamp;

30 mutually cooperating coupling means for releasable attaching the electronic module to the associated mechanical medication delivery device; and

means for storing information associated with the detected click sounds including the number of click sounds detected during setting and/or expelling of a dose, and storing the associated time stamp.

BRIEF DESCRIPTION OF THE DRAWINGS

The present invention will now be explained with reference to the accompanying drawings wherein

Fig. 1 shows an electronic module according to the present invention, and

- 5 Fig. 2 shows a block diagram of a simple version of an electronic module according to the present invention.

While the invention is susceptible to various modifications and alternative forms, specific embodiments have been shown by way of example in the drawings and will be described in detail herein. It should be understood, however, that the invention is not intended to be
10 limited to the particular forms disclosed. Rather, the invention is to cover all modifications, equivalents, and alternatives falling within the spirit and scope of the invention as defined by the appended claims.

DETAILED DESCRIPTION OF THE INVENTION

In its most general aspect the present invention relates to a portable electronic module
15 capable of measuring acoustical and/or vibrational signals generated in response to relative movements of internal parts constituting at least part of a mechanical medication delivery device to which the portable electronic module is attached. Such internal parts can be mechanical parts which during movements generate for example acoustical sounds, such as click sounds.

20 The portable electronic module according to the present invention is intended for mapping the manner of use of a medical device, such as a medication delivery device capable of delivering set doses of insulin, over a given period of time. In order to obtain reliable mapping results, such given period of time typically extends over several months. Thus, the portable electronic module according to the present invention is adapted to be attached to a
25 medication delivery device typically for several months whereby the manner of use of the medication delivery device can be precisely mapped. In order to do this time stamping of events occurring in the medication delivery device is important in that time stamping makes it possible to arrange detected events in a chronological correct order.

30 The electronic module further comprises means for storing or recording information generated from the measured signals, and means for optionally transmitting such stored or recorded information to an external module or device for further processing. This external

module or device can be a computer, a cellular phone, a PDA or a similar device capable of for example displaying injected doses of insulin as a function of time. Thus, by transferring the stored data to a computer the user of the medication delivery device may have his/hers injection pattern displayed on a screen, and he/she can chose to store the displayed
5 information in the computer.

The transmitting or transferring of data from the electronic module to the computer/cellular phone/PDA can be via a wire plugged into the electronic module. Alternatively, the transmitting or transferring of data between the module and the computer/cellular phone/PDA can be accomplished by wireless means, such as DECT or Bluetooth.

10 In order to measure acoustical signals the electronic module comprises some sort of pressure sensor, such as a miniature microphone. The miniature microphone is capable of picking up mechanical "click sounds" generated when engaging plastic or metal parts of the medication delivery device are moved relative to each other – typically in and out of engagement.

Electronic circuits connected to the miniature microphone may assist filtering the picked-up
15 "click sounds". Thus, if the detected "click-sound" falls within a certain frequency range, say a low frequency range, a dose of medicament is being set. Similarly, if the detected "click-sounds" falls within a high frequency range a dose of medicament is being expelled from the medication delivery device. Typically, the mechanical clicking is measured by counting the number of clicks. One click corresponds to a certain amount of for example expelled
20 medicament. Thus, by counting the number of clicks during an expelling sequence the amount of medicament expelled from the medicament delivery device can easily be calculated.

The electronic module can also store or record a complete sequence of events. Such a sequence can for example include the switching on of the electronic module, the recording of
25 low frequency click sounds in response to a dose being set and the recording of high frequency click sounds in response to a dose being expelled.

The electronic module also stores corresponding values of the number of click sounds and time/date. Thus, when the user of the medication delivery device transmits or transfers the stored data from the electronic module to a computer, the time, date, amount of each set
30 dose and the amount of each injected dose may be visualized to the user of the mechanical medication delivery device.

It should be mentioned, that the electronic module according to the present invention may also measure other signals than acoustical signals. An example of such other type of signal

may be vibrational signals. Obviously, if such non-acoustical signals are to be measured other types of sensors are to be applied. For example, a miniature accelerator is capable of measuring vibrational signals.

5 The electronic module according to the present invention may also house a signal processor for full or partial processing of measured signals. Thus, the information transmitted or transferred to external units may be raw or pre-processed data.

Referring now to Fig. 1 an electronic module 1 according to the present invention is shown. As seen in Fig. 1 the module 1 is mountable on the housing of a mechanical medication delivery device 2. The module is attached to the upper part of the medication delivery device,
10 i.e. where the arrangement for driving a piston rod so as to expel a medicament is positioned, using magnetic means, such as permanent magnetic means, provided in the electronic module. However, other coupling arrangements between module and device are also applicable. The piston rod moves a piston of a cartridge towards a proximal end of the medication delivery device.

15 The module may, as already mentioned, be equipped with appropriate sensors suitable for detecting acoustical and/or vibrational signals generated in response to normal operation of the medication delivery device. For example, two meshing gear-wheels (not shown) can produce click sounds which may be recorded by a miniature pressure sensor, such as a miniature microphone, mounted in the housing of the module. The module may be adapted
20 to process the recorded signals by for example counting the number of recorded "clicks" so that the amounts of a set dose of medicament and an expelled dose of medicament can be stored in the module. As already mentioned information stored in the module can be transferred to an external device, such as a portable computer, for further processing.

An exterior surface part of the housing of the electronic module according to the present
25 invention may support an electrical switch and/or a display member. The electrical switch is preferably implemented as a capacitive finger touch switch. Upon activation of this switch the electronics of the electronic module is powered from a battery positioned in the housing of the electronic module. Alternatively, the electrical switch can be incorporated within the housing of the electronic module. Such an incorporated switch is activated during normal use
30 of the mechanical medication delivery device. Thus, the user of the medication delivery device should not specifically address activation of the switch in that the switch is automatically activated when the mechanical medication delivery device is held in the hand of the user of the device. The display member can be a flat panel LCD array capable of providing valuable information to the user of the electronic module.

- Fig. 2 shows a block diagram of a simple version of the electronic module according to the present invention. The electronic module depicted in Fig. 2 is adapted to record acoustical click sounds generated in response to doses being set and doses being expelled. As seen, the portable electronic module comprises a microphone, a low-pass filter and an A/D converter.
- 5 Thus, acoustical signals picked-up by the microphone are first low-pass filtered and then converted to a digital format before being provided to a microprocessor. In terms of power the electronic module is powered by a built-in battery which powers the module when for example a capacitive touch pad is activated. This activation is performed when for example a finger tip is positioned on the touch pad.
- 10 The microprocessor is in communication with a Boot Flash within which the control software for the microprocessor is stored. In order to communicate with the surroundings the electronic module is equipped with an optical communication port, IrDA, which allows recorded data to be communicated to an external device. Obviously, this communication with the surroundings may be accomplished by other means, such as a physical wire connecting
- 15 the electronic device with the external device, Bluetooth, DECT etc. The real time clock, RTC, ensures that data relating to for example dose setting and dose expelling are stored or recorded along with time and date associated thereto. In addition, the switch-on time of the module can be stored along with these parameters.

CLAIMS:

1. A method for wirelessly monitoring the operation of a mechanical medication delivery device, the method comprising the steps of:
 - providing a mechanical medication delivery device for setting an amount of a dose of a medicament and injecting of set doses, said mechanical medication delivery device generating click sounds during setting and/or expelling of a dose of a medicament whereby the number of click sounds correspond to an amount of a set dose and/or an expelled dose;
 - providing a portable electronic module, the electronic module comprising a module housing and detector means mounted in the module housing;
 - attaching the electronic module to said mechanical medication delivery device using mutually cooperating coupling means for realisably coupling the electronic module to the mechanical medication delivery device;
 - detecting, using the electronic module, click sounds generated in response to an event or action occurring within the associated medication delivery device during the setting and/or expelling of a dose, and associating with each event or action a time stamp; and
 - storing, using storage means of the electronic module, information associated with the detected click sounds including the number of click sounds detected during the setting and/or expelling of a dose, and storing the associated time stamp.
2. The method according to claim 1, wherein the click sounds are generated in response to setting a dose of medicament by activating a dose setting member of the associated mechanical medication delivery device.
3. The method according to claim 1, wherein the click sounds are generated in response to expelling a dose of medicament from the associated mechanical medication delivery device.
4. the method according to any one of claims 1 to 3, further comprising the step of transmitting stored information to an, in relation to the electronic module, external module or unit for further processing.
5. The method according to claim 4, wherein transmitting to the external module or unit is provided by wireless means, such as Bluetooth.

6. A portable electronic module adapted to be releasable attached to an associated mechanical medication delivery device, said mechanical medication delivery device being configured for setting the amount of a dose of a medicament and injecting of set doses, the mechanical medication delivery device generating click sounds during setting and/or expelling of a dose of a medicament whereby the number of click sounds correspond to an amount of a set dose and/or an expelled dose, the electronic module comprising:

a module housing;

detector means mounted in the module housing for wirelessly detecting click sounds generated in response to an event or action occurring within the associated mechanical medication delivery device during the setting and/or expelling of a dose, and associating with each event or action a time stamp;

mutually cooperating coupling means for releasable attaching the electronic module to the associated mechanical medication delivery device; and

means for storing information associated with the detected click sounds including the number of click sounds detected during setting and/or expelling of a dose, and storing the associated time stamp.

7. The electronic module according to claim 6, further comprising means for transmitting stored information to an external module or unit for further processing.

8. The electronic module according to claim 7, further comprising signal processor means adapted to process the detected click sounds prior to storing information associated therewith.

9. The electronic module according to claim 7 or 8, wherein the detecting means comprises a microphone capable of detecting click sounds generated in the associated mechanical medication delivery device.

10. The electronic module according to claim 7 or 8, wherein the detecting means comprises an accelerometer capable of detecting click sounds generated in the associated mechanical medication delivery device.

11. The electronic module according to any one of claims 7 to 10, wherein the transmitting means comprise means for wirelessly transmitting information from the electronic module to the external module or unit.

12. The electronic module according to claim 11, wherein the wireless transmitting of information from the electronic module to the external module or unit is provided by Bluetooth.

13. The electronic module according to any one of claims 6 to 12, further comprising display means adapted to provide visual information to the user of the electronic module.

14. The electronic module according to any one of claims 6 to 13, further comprising a touch pad switch adapted to switch on the electronic module upon activation.

15. The electronic module according to any one of claims 6 to 13, further comprising contact means adapted to switch on the electronic module during normal use of the medication delivery device.

1/2

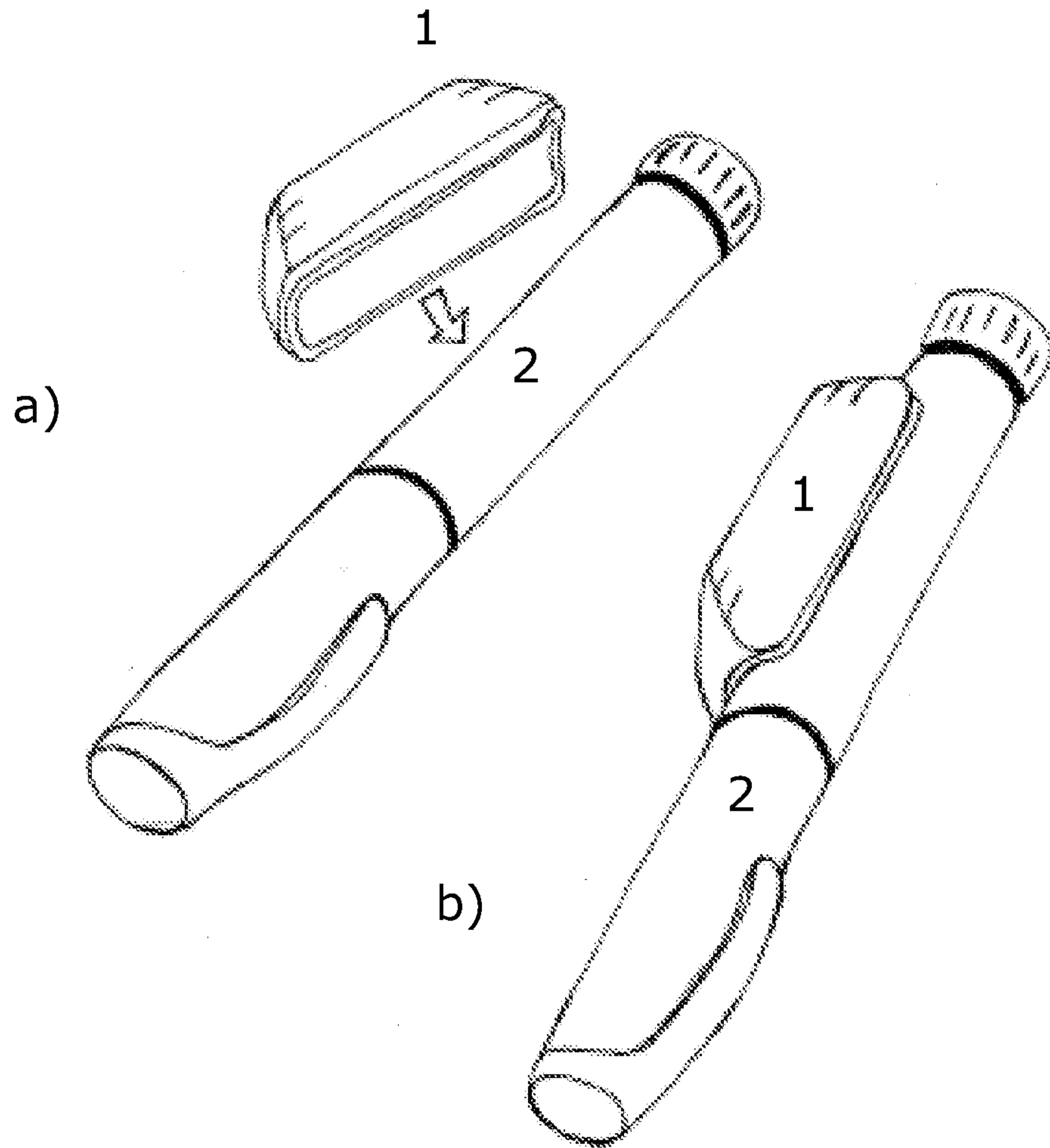

Fig. 1

2/2

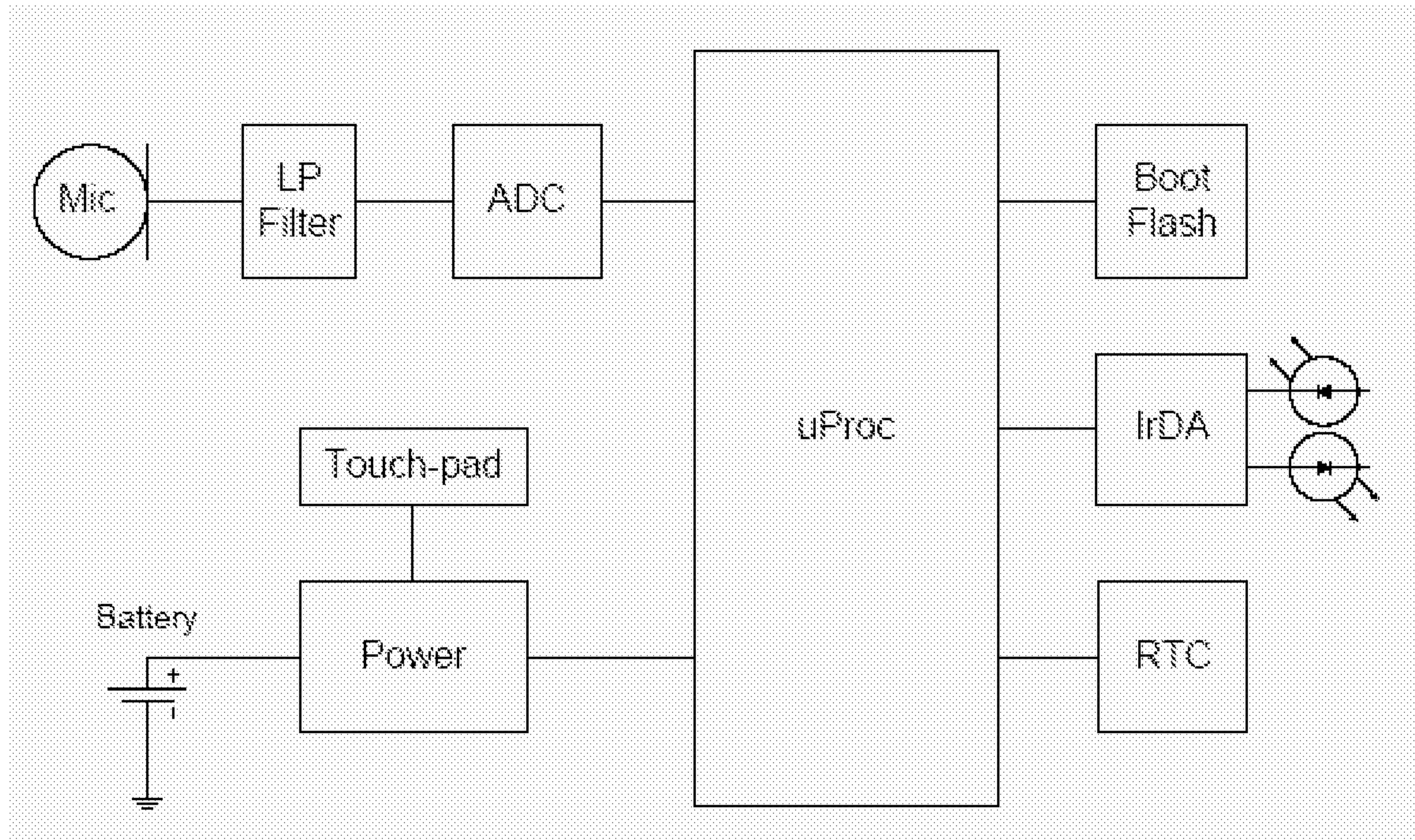

Fig. 2

