



(11) **EP 1 925 708 B1**

(12) **EUROPEAN PATENT SPECIFICATION**

(45) Date of publication and mention of the grant of the patent:
13.05.2009 Bulletin 2009/20

(51) Int Cl.:
D06F 39/00 (2006.01)

(21) Application number: **06124604.7**

(22) Date of filing: **22.11.2006**

(54) **Laundry weight determining method and washing machine implementing such a method**

Verfahren zur Bestimmung des Gewichts der Wäsche und Waschmaschine zur Durchführung des Verfahrens

Procédé pour déterminer le poids du linge dans une machine à laver et machine à laver utilisant un tel procédé

(84) Designated Contracting States:
AT BE BG CH CY CZ DE DK EE ES FI FR GB GR HU IE IS IT LI LT LU LV MC NL PL PT RO SE SI SK TR

(43) Date of publication of application:
28.05.2008 Bulletin 2008/22

(73) Proprietor: **Electrolux Home Products Corporation N.V.**
1930 Zaventem (BE)

(72) Inventors:
• **Potantsev, Oleg**
197374 St. Petersburg (RU)

- **Argudyaev, Sergey**
197198 St. Petersburg (RU)
- **Leonenkov, Sergey**
191180 St. Petersburg (RU)
- **Casagrande, Stefano**
33090 Vito D'Asio (IT)

(74) Representative: **Nardoni, Andrea et al**
Electrolux Italia S.p.A.
Corso Lino Zanussi, 30
33080 Porcia (PN) (IT)

(56) References cited:
DE-U1- 29 812 393 **GB-A- 2 225 030**
GB-A- 2 247 250 **JP-A- 2 241 493**

EP 1 925 708 B1

Note: Within nine months of the publication of the mention of the grant of the European patent in the European Patent Bulletin, any person may give notice to the European Patent Office of opposition to that patent, in accordance with the Implementing Regulations. Notice of opposition shall not be deemed to have been filed until the opposition fee has been paid. (Art. 99(1) European Patent Convention).

Description

[0001] The present invention relates to a method of determining the laundry weight inside a washing machine drum, and to a washing machine implementing such a method (e.g. see document GB-A-2247250).

[0002] More specifically, the present invention relates to a method of determining the laundry weight inside the drum of a rotary-drum household washing machine, to which the following description refers purely by way of example.

[0003] As is known, household washing machines are frequently operated with only a partial load, i.e. to wash a smaller amount of laundry than the maximum amount for which the machine is designed, with all the disadvantages this entails in terms of water, detergent, and electricity consumption, in that washing machine wash cycles are traditionally optimized with a view to full-load operation of the machine.

[0004] To reduce waste caused by operating the machine with only a partial load, some recently marketed washing machine models are designed to optimize the wash cycle as a function of the actual load. In some of these models, this even goes so far as to meter the water and detergent as a function of the amount and characteristics of the laundry in the washing machine drum, with obvious advantages in terms of reducing water, detergent, and electricity consumption per wash cycle.

[0005] Unfortunately, the methods currently employed to determine the laundry weight inside the washing machine drum are not altogether accurate, with the result that, at times, the electronic central control unit of the machine may significantly underestimate the amount of water and detergent required for a successful wash cycle, with all the disadvantages this entails.

[0006] More specifically, most recently marketed washing machine models determine the laundry weight inside the drum on the basis of the time taken by the loaded drum to stop on its own, after being rotated at a reference angular speed. The time taken by the drum to stop, in fact, is a function of the kinetic energy accumulated by the loaded drum, and therefore of the weight of the laundry inside the drum.

[0007] Unfortunately, using the stop time of the drum to determine the actual weight of the laundry inside the drum fails to take into account the fact that, when the laundry is unevenly distributed inside the drum, a significant part of the kinetic energy of the system is dissipated by the springs and shock-absorbers suspending the wash assembly to the machine frame, with the result that laundry distributed particularly unevenly inside the drum may come to a complete stop in a noticeably shorter time than the same amount of evenly distributed laundry.

[0008] Given the impossibility of determining the amount of energy dissipated by the suspensions connecting the wash assembly to the machine frame, the central control unit is obviously forced to overestimate the amount of laundry in the drum to ensure a successful wash cycle even if the laundry is distributed unevenly inside the drum.

[0009] It is an object of the present invention to provide a washing machine designed to determine, more accurately and economically, the weight of the laundry inside the drum.

[0010] According to the present invention, there is provided a method of determining the laundry weight inside a washing machine drum, as claimed in Claim 1 and preferably, though not necessarily, any one of the Claims depending directly or indirectly on Claim 1.

[0011] According to the present invention, there is also provided a washing machine, as claimed in Claim 8 and preferably, though not necessarily, any one of the Claims depending directly or indirectly on Claim 8.

[0012] A non-limiting embodiment of the present invention will be described by way of example with reference to the accompanying drawings, in which:

Figure 1 shows a view in perspective, with parts in section and parts removed for clarity, of a washing machine in accordance with the teachings of the present invention;

Figure 2 shows a schematic view of a component part of the Figure 1 washing machine;

Figures 3, 4 and 5 show time graphs of quantities related to operation of the Figure 1 washing machine.

[0013] Number 1 in Figure 1 indicates as a whole a washing machine, which is particularly advantageous for home use, and substantially comprises a supporting frame 2 resting on the floor; a preferably, though not necessarily, cylindrical wash tub 3 suspended in floating manner inside frame 2 by means of a number of coil springs 4 (only one shown in Figure 1) preferably, though not necessarily, combined with one or more known shock-absorbers 5; a rotary drum 6 housed in axially rotating manner inside wash tub 3; and a drive unit 7 connected mechanically to drum 6 to rotate it about the longitudinal axis A of the drum inside wash tub 3.

[0014] Wash tub 3, drum 6, and the other component parts of washing machine 1 suspended from frame 2 by coil springs 4 form the wash assembly of the washing machine.

[0015] With reference to Figures 1 and 2, washing machine 1 also comprises a laundry weight detecting device 8 for determining the weight of the laundry currently inside drum 6, and for communicating the weight value to the electronic central control unit 9 of washing machine 1, which in turn optimizes the wash cycle parameters in known manner as a function of the actual weight of the laundry inside drum 6.

[0016] More specifically, unlike known solutions, detecting device 8 determines, instant by instant, the value of length H of at least one of the coil springs 4 suspending wash tub 3 - hereinafter also referred to as the reference coil spring 4 - as drum 6 is rotated about longitudinal axis A at a preferably, though not necessarily, constant angular speed ω_0 ; and then determines the actual weight of the laundry inside drum 6 by extrapolating said value from the time pattern H(t) of length H of reference coil spring 4 (Figure 3) over a predetermined control time interval ΔT as drum 6 rotates at angular speed ω_0 .

[0017] More specifically, detecting device 8 statistically determines the mean value H_m of length H of reference coil spring 4 over the time interval ΔT in which drum 6 rotates at angular speed ω_0 ; and then determines the total weight of the wash assembly, i.e. also including the laundry inside drum 6, weighing on coil springs 4, on the basis of the mean value H_m of length H of reference coil spring 4, the weight distribution of the wash assembly between the coil springs 4 supporting wash tub 3, and the mechanical characteristics of reference coil spring 4.

[0018] Finally, detecting device 8 extrapolates the total weight m_{tot} of the laundry currently inside drum 6, by subtracting the "no-load" weight of the wash assembly, i.e. the weight of the wash assembly with no laundry inside drum 6, from the total weight of the wash assembly deduced from the mean value H_m of length H of reference coil spring 4.

[0019] In connection with the above, it should be pointed out that the "no-load" weight of the wash assembly, the weight distribution of the wash assembly between the coil springs 4 supporting the wash assembly, and the mechanical characteristics of reference coil spring 4 are specific structural parameters of washing machine 1 that can be determined easily at the machine design stage.

[0020] Detecting device 8 preferably, though not necessarily, also processes the time pattern H(t) of length H of reference coil spring 4 (Figure 3) over time interval ΔT to statistically determine the value of the deviation ΔH in the time pattern H(t) of length H of coil spring 4 over time interval ΔT ; extrapolates from the value of deviation ΔH in the time pattern H(t) of length H of reference coil spring 4 a coefficient of unbalance indicating the degree of unbalance of the laundry currently inside drum 6; and, finally, transmits the coefficient of unbalance to electronic central control unit 9 of washing machine 1.

[0021] More specifically, according to a kinematic model of the behaviour of the laundry in drum 6, the laundry in drum 6 can be divided into two distinct masses : one distributed evenly inside drum 6, and the other concentrated at one point on the lateral wall of drum 6 and responsible for the vibration absorbed by coil springs 4 and shock-absorbers 5.

[0022] On the basis of the above kinematic model, detecting device 8 extrapolates the weight m' of the laundry mass theoretically concentrated at one point on the lateral wall of drum 6 on the basis of the value of deviation ΔH in the time pattern H(t) of length H of reference coil spring 4, the weight distribution of the wash assembly between the coil springs 4 supporting wash tub 3, and the mechanical characteristics of reference coil spring 4. As drum 6 rotates, in fact, the laundry mass theoretically concentrated at one point on the lateral wall of drum 6 produces mechanical vibration, which is absorbed by coil springs 4 and shock-absorbers 5, and which results in continual variations in the length of the coil springs 4, including reference coil spring 4, supporting the wash assembly.

[0023] In addition, detecting device 8 also determines the weight m'' of the laundry mass distributed evenly inside drum 6 as the difference between the total weight m_{tot} of the laundry in drum 6, and the weight m' of the laundry mass concentrated on the lateral wall of drum 6.

[0024] With reference to Figures 1 and 2, in the example shown, detecting device 8 indirectly determines the instantaneous value of length H of reference coil spring 4 by exploiting the fact that the body of coil spring 4 is made of metal and so constitutes a coil 4 of electrically conducting material, which has an inductance L of an instantaneous value mathematically correlated to the instantaneous value of length H of coil 4 of electrically conducting material, i.e. of coil spring 4.

[0025] In this case, the instantaneous value in microHenry (10^{-6} Henry) of inductance L of reference coil spring 4 is inversely proportional to length H of reference coil spring 4, and can be defined by the following empiric equation:

$$L = 2,54 \cdot 10^{-2} \frac{r^2 N^3}{9 r N + 10 H}$$

where r is the outside radius of the turns of reference coil spring 4; N is the number of turns of reference coil spring 4; and H is the instantaneous value of the length of reference coil spring 4.

[0026] In the example shown, detecting device 8 indirectly determines the instantaneous value of length H of reference coil spring 4 by continuous measurement of the frequency f of the electric signal generated by an LC oscillating circuit, in which the inductance of the LC oscillating circuit which contributes in determining the value of the natural oscillation frequency f of the electric signal is defined by reference coil spring 4.

[0027] With particular reference to Figure 2, detecting device 8 comprises an LC oscillating circuit 10 incorporating

reference coil spring 4 as an inductor, and which generates an electric signal having a natural oscillation frequency f (Figure 4) which is mathematically correlated to the constant capacitance value of the standard capacitor integrated in LC oscillating circuit 10, and to the time-variable value of inductance L of reference coil spring 4.

[0028] More specifically, reference coil spring 4 is electrically insulated from wash tub 3 and frame 2, and is connected parallel to the standard capacitor of LC oscillating circuit 10 by two known electric leads 11, so as to be incorporated in LC oscillating circuit 10; and detecting device 8 also comprises a signal processing unit 12, which processes the electric signal from LC oscillating circuit 10 to determine the total weight m_{tot} of the laundry in drum 6, and to communicate the total weight value to electronic central control unit 9 of washing machine 1.

[0029] Signal processing unit 12 preferably, though not necessarily, also processes the electric signal from LC oscillating circuit 10 to determine the weight m' of the laundry mass theoretically concentrated on the lateral wall of drum 6, and the weight m'' of the laundry mass theoretically distributed evenly inside drum 6.

[0030] More specifically, the electric signal from LC oscillating circuit 10 has a natural oscillation frequency f mathematically correlated to the capacitance value of the standard capacitor and to the value of inductance L of reference coil spring 4 by the following equation:

$$f = \frac{1}{2\pi\sqrt{LC}} = \frac{10^4}{2\pi \cdot \sqrt{2,54} \cdot \sqrt{C}} \frac{\sqrt{9rN + 10H}}{\sqrt{r^2 N^3}}$$

where C is the capacitance value of the standard capacitor; r is the outside radius of the turns of reference coil spring 4; N is the number of turns of reference coil spring 4; and H is the instantaneous value of the length of reference coil spring 4.

[0031] Since some of the above quantities are constant and can be determined empirically at the manufacturing stage of washing machine 1, the instantaneous value of length H of reference coil spring 4 is mathematically correlated to the frequency f of the electric signal from LC oscillating circuit 10 by the following empiric equation:

$$H = \alpha f^2 - \beta$$

where α and β are two constants that can be determined empirically and which depend on the structure of reference coil spring 4; and f is the instantaneous frequency value of the electric signal from LC oscillating circuit 10.

[0032] Signal processing unit 12 therefore processes the electric signal from LC oscillating circuit 10 to reconstruct the time pattern $f(t)$ of oscillation frequency f of said signal (Figure 4) over a predetermined time interval ΔT in which drum 6 rotates at angular speed ω_0 ; statistically processes the electric signal from LC oscillating circuit 10 to determine the mean value f_m of frequency f of said signal over the time interval ΔT in which drum 6 rotates at angular speed ω_0 ; and, finally, calculates the total weight m_{tot} of the laundry currently inside drum 6 on the basis of mean value f_m of frequency f of the electric signal from LC oscillating circuit 10 over the time interval ΔT in which drum 6 rotates at angular speed ω_0 .

[0033] More specifically, signal processing unit 12 calculates the total weight m_{tot} of the laundry currently inside drum 6 on the basis of the mean value f_m of frequency f of the electric signal from LC oscillating circuit 10, and taking into account the total weight distribution of the wash assembly of washing machine 1 between coil springs 4 supporting wash tub 3.

[0034] Signal processing unit 12 preferably, though not necessarily, also statistically processes the electric signal from LC oscillating circuit 10 to determine the value of the deviation Δf in the time pattern $f(t)$ of frequency f of the electric signal (Figure 4) over the time interval ΔT in which drum 6 rotates at angular speed ω_0 ; extrapolates from the value of deviation Δf in the time pattern $f(t)$ of frequency f of the electric signal from LC oscillating circuit 10 a coefficient of unbalance indicating the degree of unbalance of the laundry currently inside drum 6; and, finally, transmits the coefficient of unbalance to electronic central control unit 9 of washing machine 1.

[0035] More specifically, on the basis of the relationship between frequency f of the electric signal from LC oscillating circuit 10 and length H of the reference coil spring, signal processing unit 12 extrapolates the weight m' of the laundry mass theoretically concentrated at one point on the lateral wall of drum 6 on the basis of the value of deviation Δf in the time pattern $f(t)$ of frequency f of the electric signal from LC oscillating circuit 10; and the weight m'' of the laundry mass theoretically distributed evenly inside drum 6 as the difference between the total weight m_{tot} of the laundry in drum 6 and the weight m' of the laundry mass concentrated on the lateral wall of drum 6.

[0036] With reference to Figures 1 and 5, detecting device 8 preferably, though not necessarily, also comprises a

position sensor 13 (e.g. a Hall-effect sensor) facing drum 6, and which determines when drum 6 is in a reference angular position inside wash tub 3, and supplies an electric signal $s(t)$ indicating when drum 6 is in the reference angular position.

[0037] In this case, signal processing unit 12 compares the electric signal $s(t)$ from sensor 13 with the time pattern $f(t)$ of oscillation frequency f of the electric signal from LC oscillating circuit 10 to determine the value of the time phase shift ϕ between the instant drum 6 reaches the reference angular position, and the instant frequency f of the electric signal from LC oscillating circuit 10 reaches its maximum (or minimum) value, i.e. the instant length H of reference coil spring 4 reaches its maximum (or minimum) value; and then calculates, on the basis of the value of time phase shift ϕ and the angular speed ω_0 of drum 6, the position of the point on the lateral wall of drum 6 at which the laundry mass unevenly distributed inside drum 6 is theoretically concentrated.

[0038] The information concerning weight m' and the position, on the lateral wall of drum 6, of the barycentre of the laundry distributed unevenly, i.e. in unbalanced manner, inside drum 6, can then be used by electronic central control unit 9 of washing machine 1 as reference parameters by which to selectively move drum 6 in controlled manner in an attempt to distribute the laundry inside drum 6 more evenly.

[0039] Operation of washing machine 1 is easily deducible from the foregoing description with no further explanation required.

[0040] As regards operation of laundry weight detecting device 8, on the other hand, electronic central control unit 9 of washing machine 1 activates drive unit 7 to rotate drum 6 about longitudinal axis A at angular speed ω_0 , and then activates detecting device 8, which determines the time pattern $H(t)$ of length H of reference coil spring 4 as drum 6 rotates at angular speed ω_0 .

[0041] More specifically, signal processing unit 12 of detecting device 8 acquires, instant by instant, the electric signal from LC oscillating circuit 10 incorporating reference coil spring 4 as an inductor, to reconstruct the time pattern $f(t)$ of oscillation frequency f of the electric signal (Figure 4), which in turn is proportional to the time pattern $H(t)$ of length H of reference coil spring 4 (Figure 3).

[0042] On acquiring the time pattern $H(t)$ of length H of reference coil spring 4, signal processing unit 12 statistically processes time pattern $H(t)$ of length H of reference coil spring 4 to determine the mean value H_m of length H of reference coil spring 4 over the time interval ΔT in which drum 6 rotates at angular speed ω_0 ; and then calculates the total weight m_{tot} of the laundry currently inside drum 6 on the basis of mean value H_m of length H of reference coil spring 4, and taking into account the weight distribution of the wash assembly between the coil springs 4 supporting wash tub 3, and the mechanical characteristics of reference coil spring 4.

[0043] In this case, signal processing unit 12 statistically processes the time pattern $f(t)$ of oscillation frequency f of the electric signal from LC oscillating circuit 10 to determine the mean value f_m of frequency f of the electric signal over time interval ΔT , and then calculates the total weight m_{tot} of the laundry currently inside drum 6 on the basis of mean value f_m of frequency f of the electric signal from LC oscillating circuit 10.

[0044] When provided for, signal processing unit 12 also statistically processes the time pattern $H(t)$ of length H of reference coil spring 4 to determine the value of deviation ΔH in the time pattern $H(t)$ of length H of reference coil spring 4 over time interval ΔT ; and then extrapolates from the value of deviation ΔH in the time pattern $H(t)$ of length H of reference coil spring 4 the weight m' of the laundry mass theoretically concentrated at one point on the lateral wall of drum 6, i.e. a coefficient of unbalance indicating the degree of unbalance of the laundry currently inside drum 6.

[0045] In this case, signal processing unit 12 statistically processes the time pattern $f(t)$ of oscillation frequency f of the electric signal from LC oscillating circuit 10 to determine the value of deviation Δf in the time pattern $f(t)$ of oscillation frequency f of the electric signal; and then extrapolates from the value of deviation Δf in the time pattern $f(t)$ of oscillation frequency f of the electric signal from LC oscillating circuit 10 the weight m' of the mass of laundry theoretically concentrated at one point on the lateral wall of drum 6.

[0046] With reference to Figure 5, on acquiring the time pattern $H(t)$ of length H of reference coil spring 4, signal processing unit 12 preferably, though not necessarily, also compares the electric signal $s(t)$ from position sensor 13 with the time pattern $H(t)$ of length H of reference coil spring 4, or rather, with the time pattern $f(t)$ of oscillation frequency f of the electric signal from LC oscillating circuit 10, to determine the value of the time phase shift Φ between the instant drum 6 reaches said reference angular position, and the instant frequency f of the electric signal from LC oscillating circuit 10 reaches its maximum (or minimum) value; and then calculates, on the basis of the value of time phase shift Φ and the angular speed ω_0 of drum 6, the exact position of the point, on the lateral wall of drum 6, at which the mass of laundry unevenly distributed inside drum 6 is theoretically concentrated.

[0047] The advantages of the method of determining the laundry weight inside drum 6, and of detecting device 8 implementing such a method, are obvious: using as a reference quantity the length H of one of the coil springs 4 supporting wash tub 3, detecting device 8 is able to determine the laundry weight inside drum 6 extremely accurately, and regardless of the way in which the laundry is distributed inside drum 6.

[0048] Laundry weight detecting device 8 is also extremely cheap to produce, and can be integrated easily in currently marketed washing machines with only minor alterations to the electronic central control units governing operation of currently marketed washing machines.

[0049] Clearly, changes may be made to the method of determining the laundry weight inside drum 6, and to detecting device 8 implementing such a method, without, however, departing from the scope of the present invention.

[0050] For example, some or all of coil springs 4 supporting wash tub 3 may be replaced with elastic members of rubber or other elastic nonmetal material. In the event reference coil spring 4 is also replaced with an elastic member of rubber or other elastic nonmetal material, detecting device 8 comprises a strain gauge or other sensor for determining the length of the elastic member instant by instant, and processes the signal from the strain gauge or similar statistically, as described above, to extrapolate the total weight m_{tot} of the laundry currently inside drum 6.

[0051] Detecting device 8 may obviously also determine the weight m' of the mass of laundry theoretically concentrated at one point on the lateral wall of drum 6 on the basis of the deviation in the time pattern of the length of the elastic reference member; the weight m'' of the mass of laundry distributed evenly inside drum 6 as the difference between the total weight m_{tot} of the laundry in drum 6, and the weight m' of the mass of laundry concentrated on the lateral wall of drum 6; and the position of the point on the lateral wall of drum 6 at which the mass of laundry unevenly distributed inside drum 6 is theoretically concentrated.

[0052] With reference to Figure 5, the signal processing unit 12 of detecting device 8 may also process the time pattern $H(t)$ of length H of reference coil spring 4, i.e. the time pattern $f(t)$ of oscillation frequency f of the electric signal generated by LC oscillating circuit 10, to determine the instant value of the angular speed of drum 6. In fact the oscillation period of the time pattern $H(t)$ of length H of reference coil spring 4 depends on the instant value of the angular speed of drum 6.

Claims

1. A method of determining the laundry weight inside the drum (6) of a washing machine (1), wherein said drum (6) is mounted to rotate inside a wash tub (3) suspended in floating manner to a supporting frame (2) by at least one elastic connecting member (4); the method being **characterized by** comprising the steps of:

- rotating the drum (6) at a predetermined angular speed;
- acquiring, instant by instant, the value of the length (H) of said elastic connecting member (4) as the drum (6) rotates at said predetermined angular speed; and
- calculating the total weight (m_{tot}) of the laundry inside said drum (6) by extrapolating it from the time pattern ($H(t)$) of the value of the length (H) of said elastic connecting member (4) as the drum (6) rotates at said predetermined angular speed.

2. A method as claimed in Claim 1, **characterized in that** said step of calculating the total weight (m_{tot}) of the laundry inside the drum (6) comprises the step of calculating the mean value (H_m) of the length (H) of said elastic connecting member (4) over a reference time interval (ΔT) in which said drum (6) rotates at the predetermined angular speed, and then extrapolating the total weight (m_{tot}) of the laundry inside the drum (6) from said mean value (H_m) of the length (H) of said elastic connecting member (4).

3. A method as claimed in Claim 1 or 2, **characterized by** also comprising the step of calculating a first coefficient of unbalance (m'), indicating the degree of unbalance of the laundry inside said drum (6), by extrapolating it from the time pattern ($H(t)$) of the value of the length (H) of said elastic connecting member (4) as the drum (6) rotates at said predetermined angular speed.

4. A method as claimed in Claim 3, **characterized in that** said step of calculating said first coefficient of unbalance (m') comprises the step of statistically calculating the value of the deviation (ΔH) in the time pattern ($H(t)$) of the length (H) of the elastic connecting member (4) over a reference time interval (ΔT) in which said drum (6) rotates at the predetermined angular speed, and then extrapolating said coefficient of unbalance (m') from the value of said deviation (ΔH) in the time pattern ($H(t)$) of the length (H) of the elastic connecting member (4).

5. A method as claimed in Claim 3 or 4, **characterized by** also comprising the step of generating a reference signal ($s(t)$) indicating when the drum (6) is in a reference angular position, and the step of calculating a second coefficient of unbalance (Φ), indicating the position of the barycentre of the laundry unevenly distributed inside said drum (6), by extrapolating it from a comparison between the time pattern ($H(t)$) of the value of the length (H) of said elastic connecting member (4) as the drum (6) rotates at said predetermined angular speed, and the time pattern ($H(t)$) of the reference signal ($s(t)$) indicating when the drum (6) is in said reference angular position.

6. A method as claimed in any one of the foregoing Claims, **characterized in that** said at least one elastic connecting member (4) is a coil spring (4) of electrically conducting material, and said step of determining instant by instant the

value of the length (H) of said elastic connecting member (4) comprises the step of measuring instant by instant the value of a physical quantity (f) related to the instantaneous value of the inductance (L) of said coil spring (4).

- 5 7. A method as claimed in Claim 6, **characterized in that** said step of measuring instant by instant the value of a physical quantity (f) related to the instantaneous value of the inductance (L) of said coil spring (4) comprises the step of measuring instant by instant the natural oscillation frequency (f) of a signal generated by an LC oscillating circuit (10) incorporating said coil spring (4) as an inductor.
- 10 8. A washing machine (1) comprising a frame (2); a wash tub (3) suspended in floating manner inside said frame (2) by means of at least one elastic connecting member (4); a drum (6) housed in axially rotating manner inside said wash tub (3); and a laundry weight detecting device (8) for determining the weight of the laundry inside said drum (6); said washing machine (1) being **characterized in that** said laundry weight detecting device (8) comprises measuring means (8, 10) for determining instant by instant the value of the length (H) of said elastic connecting member (4); and first processing means (8, 12) for calculating the total weight (m_{tot}) of the laundry in said drum (6) on the basis of the time pattern (H(t)) of the value of the length (H) of said elastic connecting member (4) as the drum (6) rotates at a predetermined angular speed.
- 15 9. A washing machine as claimed in Claim 8, **characterized in that** said first processing means (8, 12) calculate the mean value (H_m) of the length (H) of said elastic connecting member (4) over a reference time interval (ΔT) in which said drum (6) rotates at the predetermined angular speed, and then extrapolate the total weight (m_{tot}) of the laundry inside the drum (6) from the mean value (H_m) of the length (H) of said elastic connecting member (4).
- 20 10. A washing machine as claimed in Claim 8 or 9, **characterized in that** said laundry weight detecting device (8) also comprises second processing means (8, 12), which calculate a first coefficient of unbalance (m'), indicating the degree of unbalance of the laundry inside said drum (6), by extrapolating it from the time pattern (H(t)) of the value of the length (H) of the elastic connecting member (4) as the drum (6) rotates at said predetermined angular speed.
- 25 11. A washing machine as claimed in Claim 10, **characterized in that** said second processing means (8, 12) statistically calculate the value of the deviation (ΔH) in the time pattern (H(t)) of the length (H) of said elastic connecting member (4) over a reference time interval (ΔT) in which said drum (6) rotates at the predetermined angular speed, and then extrapolate said first coefficient of unbalance (m') from the value of said deviation (ΔH) in the time pattern (H(t)) of the length (H) of the elastic connecting member (4).
- 30 12. A washing machine as claimed in any one of Claims 8 to 11, **characterized in that** said at least one elastic connecting member (4) is a coil spring (4) of electrically conducting material, and the measuring means (8, 10) determine instant by instant the value of a physical quantity (f) related to the instantaneous value of the inductance (L) of said coil spring (4).
- 35 13. A washing machine as claimed in Claim 12, **characterized in that** said measuring means (8, 10) comprise an LC oscillating circuit (10), which incorporates said coil spring (4) as an inductor, and generates a signal of variable frequency (f), the instantaneous value of which is a function of the instantaneous value of the inductance (L) of said coil spring (4); said first processing means (8, 12) determining instant by instant the value of the frequency (f) of the signal generated by said LC oscillating circuit (10), to determine the time pattern (H(t)) of the length (H) of said coil spring (4).
- 40 45 14. A washing machine as claimed in any one of Claims 8 to 13, **characterized in that** said laundry weight detecting device (8) also comprises a position sensor (13) for determining when the drum (6) is in a reference angular position, and for supplying a signal (s(t)) indicating when the drum (6) is in said reference angular position; said laundry weight detecting device (8) also comprising third processing means (8, 12) for determining the time phase shift (Φ) between the signal (s(t)) generated by said position sensor (13) and the time pattern (H(t)) of the value of the length (H) of the elastic connecting member (4), and for determining a second coefficient of unbalance, indicating the position of the barycentre of the laundry unevenly distributed inside said drum (6), by extrapolating it from the value of said time phase shift (Φ).
- 50 55

Patentansprüche

1. Verfahren zur Bestimmung des Gewichts der Wäsche in der Trommel (6) einer Waschmaschine (1), wobei die

Trommel (6) drehbar in einem Laugenbehälter (3) montiert ist, der durch mindestens ein elastisches Verbindungselement (4) auf schwebende Weise an einem Tragrahmen (2) aufgehängt ist, wobei das Verfahren **dadurch gekennzeichnet ist, dass** es folgende Schritte umfasst:

- 5 - Drehen der Trommel (6) mit einer vorbestimmten Winkelgeschwindigkeit;
 - von Moment zu Moment erfolgende Erfassung des Werts der Länge (H) des elastischen Verbindungselements (4), während sich die Trommel (6) mit der vorbestimmten Winkelgeschwindigkeit dreht; und
 - Berechnen des Gesamtgewichts (m_{tot}) der Wäsche in der Trommel (6), indem es von dem Zeitmuster (H(t)) des Werts der Länge (H) des elastischen Verbindungselements (4) während der Drehung der Trommel (6) mit der vorbestimmten Winkelgeschwindigkeit extrapoliert wird.
- 10
2. Verfahren nach Anspruch 1, **dadurch gekennzeichnet, dass** der Schritt des Berechnens des Gesamtgewichts (m_{tot}) der Wäsche in der Trommel (6) den folgenden Schritt umfasst: Berechnen des Mittelwerts (H_m) der Länge (H) des elastischen Verbindungselements (4) über ein Referenzzeitintervall (ΔT), in dem sich die Trommel (6) mit der vorbestimmten Winkelgeschwindigkeit dreht, und anschließend Extrapolieren des Gesamtgewichts (m_{tot}) der Wäsche in der Trommel (6) vom Mittelwert (H_m) der Länge (H) des elastischen Verbindungselements (4).
- 15
3. Verfahren nach Anspruch 1 oder 2, **dadurch gekennzeichnet, dass** es auch folgenden Schritt umfasst: Berechnen eines ersten Ungleichgewichtskoeffizienten (m'), der das Ausmaß des Ungleichgewichts der Wäsche in der Trommel (6) anzeigt, indem er von dem Zeitmuster (H(t)) des Werts der Länge (H) des elastischen Verbindungselements (4) während der Drehung der Trommel (6) mit der vorbestimmten Winkelgeschwindigkeit extrapoliert wird.
- 20
4. Verfahren nach Anspruch 3, **dadurch gekennzeichnet, dass** der Schritt des Berechnens des ersten Ungleichgewichtskoeffizienten (m') folgenden Schritt umfasst: statistisches Berechnen des Werts der Abweichung (ΔH) im Zeitmuster (H(t)) der Länge (H) des elastischen Verbindungselements (4) über ein Referenzzeitintervall (ΔT), in dem sich die Trommel (6) mit der vorbestimmten Winkelgeschwindigkeit dreht, und anschließend Extrapolieren des Ungleichgewichtskoeffizienten (m') vom Wert der Abweichung (ΔH) im Zeitmuster (H(t)) der Länge (H) des elastischen Verbindungselements (4).
- 25
5. Verfahren nach Anspruch 3 oder 4, **dadurch gekennzeichnet, dass** es auch Folgendes umfasst: den Schritt des Erzeugens eines Referenzsignals ($s(t)$), das anzeigt, wenn sich die Trommel (6) in einer Referenzwinkelposition befindet, und den Schritt des Berechnens eines zweiten Ungleichgewichtskoeffizienten (Φ), der die Position des Schwerpunkts der ungleichmäßig in der Trommel (6) verteilten Wäsche angibt, indem er extrapoliert wird von einem Vergleich zwischen dem Zeitmuster (H(t)) des Werts der Länge (H) des elastischen Verbindungselements (4) während der Drehung der Trommel (6) mit der vorbestimmten Winkelgeschwindigkeit und dem Zeitmuster (H(t)) des Referenzsignals ($s(t)$), das anzeigt, wenn sich die Trommel (6) in der Referenzwinkelposition befindet.
- 30
6. Verfahren nach einem der vorhergehenden Ansprüche, **dadurch gekennzeichnet, dass** mindestens ein elastisches Verbindungselement (4) eine Schraubenfeder (4) aus elektrisch leitendem Material ist, und dass der Schritt der von Moment zu Moment erfolgenden Bestimmung des Werts der Länge (H) des elastischen Verbindungselements (4) folgenden Schritt umfasst: von Moment zu Moment erfolgende Messung des Werts einer physikalischen Größe (f), die mit dem momentanen Wert der Induktanz (L) der Schraubenfeder (4) in Beziehung steht.
- 35
7. Verfahren nach Anspruch 6, **dadurch gekennzeichnet, dass** der Schritt der von Moment zu Moment erfolgenden Messung einer physikalischen Größe (f), die mit dem momentanen Wert der Induktanz (L) der Schraubenfeder (4) in Beziehung steht, folgenden Schritt umfasst: von Moment zu Moment erfolgende Messung der natürlichen Schwingungsfrequenz (f) eines Signals, das von einem LC-Schwingkreis (10) erzeugt wird, der die Schraubenfeder (4) als Induktor umfasst.
- 40
8. Waschmaschine (1), umfassend einen Rahmen (2), einen Laugenbehälter (3), der durch mindestens ein elastisches Verbindungselement (4) auf schwebende Weise in dem Rahmen (2) aufgehängt ist, eine Trommel (6), die axial drehbar in dem Laugenbehälter (3) angeordnet ist, und eine Wäschegewichtserkennungsvorrichtung (8) zur Bestimmung des Gewichts der Wäsche in der Trommel (6), wobei die Waschmaschine (1) **dadurch gekennzeichnet ist, dass** die Wäschegewichtserkennungsvorrichtung (8) umfasst: Messmittel (8, 10) für eine von Moment zu Moment erfolgende Bestimmung des Werts der Länge (H) des elastischen Verbindungselements (4), und erste Verarbeitungsmittel (8, 12) zur Berechnung des Gesamtgewichts (m_{tot}) der Wäsche in der Trommel (6) auf der Basis des Zeitmusters (H(t)) des Werts der Länge (H) des elastischen Verbindungselements (4) während der Drehung der Trommel (6) mit einer vorbestimmten Winkelgeschwindigkeit.
- 45
- 50
- 55

EP 1 925 708 B1

- 5 9. Waschmaschine nach Anspruch 8, **dadurch gekennzeichnet, dass** die ersten Verarbeitungsmittel (8, 12) den Mittelwert (H_m) der Länge (H) des elastischen Verbindungselements (4) über ein Referenzzeitintervall (ΔT) berechnen, in dem sich die Trommel (6) mit der vorbestimmten Winkelgeschwindigkeit dreht, und anschließend das Gesamtgewicht (m_{tot}) der Wäsche in der Trommel (6) vom Mittelwert (H_m) der Länge (H) des elastischen Verbindungselements (4) extrapolieren.
- 10 10. Waschmaschine nach Anspruch 8 oder 9, **dadurch gekennzeichnet, dass** die Wäschegewichtserkennungsvorrichtung (8) auch zweite Verarbeitungsmittel (8, 12) umfaßt, die einen ersten Ungleichgewichtskoeffizienten (m') berechnen, der das Ausmaß des Ungleichgewichts der Wäsche in der Trommel (6) anzeigt, indem er von dem Zeitmuster ($H(t)$) des Werts der Länge (H) des elastischen Verbindungselements (4) während der Drehung der Trommel (6) mit der vorbestimmten Winkelgeschwindigkeit extrapoliert wird.
- 15 11. Waschmaschine nach Anspruch 10, **dadurch gekennzeichnet, dass** die zweiten Verarbeitungsmittel (8, 12) den Wert der Abweichung (ΔH) im Zeitmuster ($H(t)$) der Länge (H) des elastischen Verbindungselements (4) über ein Referenzzeitintervall (ΔT), in dem sich die Trommel (6) mit der vorbestimmten Winkelgeschwindigkeit dreht, statisch berechnen, und anschließend den ersten Ungleichgewichtskoeffizienten (m') vom Wert der Abweichung (ΔH) im Zeitmuster ($H(t)$) der Länge (H) des elastischen Verbindungselements (4) extrapolieren.
- 20 12. Waschmaschine nach einem der Ansprüche 8 bis 11, **dadurch gekennzeichnet, dass** das mindestens eine elastische Verbindungselement (4) eine Schraubenfeder (4) aus elektrisch leitendem Material ist, und dass die Messmittel (8, 10) von Moment zu Moment den Wert einer physikalischen Größe (f) bestimmen, die mit dem momentanen Wert der Induktanz (L) der Schraubenfeder (4) in Beziehung steht.
- 25 13. Waschmaschine nach Anspruch 12, **dadurch gekennzeichnet, dass** die Messmittel (8, 10) einen LC-Schwingkreis umfassen (10), der die Schraubenfeder (4) als Induktor enthält und ein Signal mit variabler Frequenz (f) erzeugt, dessen momentaner Wert eine Funktion des momentanen Werts der Induktanz (L) der Schraubenfeder (4) ist, wobei die ersten Verarbeitungsmittel (8, 12) von Moment zu Moment den Wert der Frequenz (f) des Signals bestimmen, das von dem LC-Schwingkreis (10) erzeugt wird, um das Zeitmuster ($H(t)$) der Länge (H) der Schraubenfeder (4) zu bestimmen.
- 30 14. Waschmaschine nach einem der Ansprüche 8 bis 13, **dadurch gekennzeichnet, dass** die Wäschegewichtserkennungsvorrichtung (8) auch einen Positionssensor (13) umfasst, um festzustellen, wenn sich die Trommel (6) in einer Referenzwinkelposition befindet, und um ein Signal ($s(t)$) zu liefern, das anzeigt, wenn sich die Trommel (6) in der Referenzwinkelposition befindet, wobei die Wäschegewichtserkennungsvorrichtung (8) auch dritte Verarbeitungsmittel (8, 12) umfasst, um die Zeitphasenverschiebung (Φ) zwischen dem vom Positionssensor (13) erzeugten Signal ($s(t)$) und dem Zeitmuster ($H(t)$) des Werts der Länge (H) des elastischen Verbindungselements (4) zu bestimmen, und um einen zweiten Ungleichgewichtskoeffizienten zu bestimmen, der die Position des Schwerpunkts der ungleichmäßig in der Trommel (6) verteilten Wäsche angibt, indem er von dem Wert der Zeitphasenverschiebung (Φ) extrapoliert wird.
- 35 40

Revendications

- 45 1. Procédé de détermination du poids de linge à l'intérieur du tambour (6) d'une machine à laver (1), dans lequel ledit tambour (6) est monté de manière à tourner à l'intérieur d'un bac à laver (3) suspendu de manière flottante à un cadre de support (2) par au moins un élément de liaison élastique (4) ; le procédé étant **caractérisé en ce qu'il** comprend les étapes consistant à :
- 50 - faire tourner le tambour (6) à une vitesse angulaire prédéterminée ;
- acquérir, à chaque instant, la valeur de la longueur (H) dudit élément de liaison élastique (4) lorsque le tambour (6) tourne à ladite vitesse angulaire prédéterminée ; et
- calculer le poids total (m_{tot}) du linge à l'intérieur dudit tambour (6) en l'extrapolant à partir du modèle temporel ($H(t)$) de la valeur de la longueur (H) dudit élément de liaison élastique (4) lorsque le tambour (6) tourne à ladite vitesse angulaire prédéterminée.
- 55 2. Procédé selon la revendication 1, **caractérisé en ce que** ladite étape de calcul du poids total (m_{tot}) du linge à l'intérieur du tambour (6) comprend l'étape consistant à calculer la valeur moyenne (H_m) de la longueur (H) dudit élément de liaison élastique (4) sur un intervalle de temps de référence (ΔT) dans lequel ledit tambour (6) tourne à

la vitesse angulaire prédéterminée, et à extrapoler ensuite le poids total (m_{tot}) du linge à l'intérieur du tambour (6) à partir de ladite valeur moyenne (H_m) de la longueur (H) dudit élément de liaison élastique (4).

- 5 3. Procédé selon la revendication 1 ou 2, **caractérisé en ce qu'**il comprend également l'étape consistant à calculer un premier coefficient de balourd (m'), indiquant le degré de balourd du linge à l'intérieur dudit tambour (6), en l'extrapolant à partir du modèle temporel ($H(t)$) de la valeur de la longueur (H) dudit élément de liaison élastique (4) lorsque le tambour (6) tourne à ladite vitesse angulaire prédéterminée.
- 10 4. Procédé selon la revendication 3, **caractérisé en ce que** ladite étape de calcul dudit premier coefficient de balourd (m') comprend l'étape consistant à calculer statistiquement la valeur de la déviation (ΔH) dans le modèle temporel ($H(t)$) de la longueur (H) de l'élément de liaison élastique (4) sur un intervalle de temps de référence (ΔT), dans lequel ledit tambour (6) tourne à la vitesse angulaire prédéterminée, et à extrapoler ensuite ledit coefficient de balourd (m') à partir de la valeur de ladite déviation (ΔH) dans le modèle temporel ($H(t)$) de la longueur (H) de l'élément de liaison élastique (4).
- 15 5. Procédé selon la revendication 3 ou 4, **caractérisé en ce qu'**il comprend également l'étape consistant à générer un signal de référence ($s(t)$) indiquant le moment où le tambour (6) se trouve dans une position angulaire de référence, et l'étape consistant à calculer un deuxième coefficient de balourd (Φ), indiquant la position du barycentre du linge réparti irrégulièrement à l'intérieur dudit tambour (6), en l'extrapolant à partir d'une comparaison entre le modèle temporel ($H(t)$) de la valeur de la longueur (H) dudit élément de liaison élastique (4) lorsque le tambour (6) tourne à ladite vitesse angulaire prédéterminée, et le modèle temporel ($H(t)$) du signal de référence ($s(t)$) indiquant le moment où le tambour (6) se trouve dans ladite position angulaire de référence.
- 20 6. Procédé selon l'une quelconque des revendications précédentes, **caractérisé en ce que** ledit au moins un élément de liaison élastique (4) est un ressort hélicoïdal (4) fabriqué à partir de matériau électriquement conducteur, et ladite étape consistant à déterminer à chaque instant la valeur de la longueur (H) dudit élément de liaison élastique (4) comprend l'étape consistant à mesurer à chaque instant la valeur d'une quantité physique (f) liée à la valeur instantanée de l'inductance (L) dudit ressort hélicoïdal (4).
- 25 7. Procédé selon la revendication 6, **caractérisé en ce que** ladite étape de mesure à chaque instant de la valeur d'une quantité physique (f) liée à la valeur instantanée de l'inductance (L) dudit ressort hélicoïdal (4) comprend l'étape consistant à mesurer à chaque instant la fréquence d'oscillation naturelle (f) d'un signal généré par un circuit oscillant LC (10) comprenant ledit ressort hélicoïdal (4) comme inducteur.
- 30 8. Machine à laver (1) comprenant un cadre (2) ; un bac à laver (3) suspendu de manière flottante à l'intérieur dudit cadre (2) au moyen d'au moins un élément de liaison élastique (4) ; un tambour (6) logé de manière rotative axialement à l'intérieur dudit bac à laver (3) ; et un dispositif de détection de poids du linge (8) pour déterminer le poids du linge à l'intérieur dudit tambour (6) ; ladite machine à laver (1) étant **caractérisée en ce que** ledit dispositif de détection de poids du linge (8) comprend des moyens de mesure (8, 10) pour déterminer à chaque instant la valeur de la longueur (H) dudit élément de liaison élastique (4) ; et des premiers moyens de traitement (8, 12) pour calculer le poids total (m_{tot}) du linge dans ledit tambour (6) sur la base du modèle temporel ($H(t)$) de la valeur de la longueur (H) dudit élément de liaison élastique (4) lorsque le tambour (6) tourne à une vitesse angulaire prédéterminée.
- 35 9. Machine à laver selon la revendication 8, **caractérisée en ce que** lesdits premiers moyens de traitement (8, 12) calculent la valeur moyenne (H_m) de la longueur (H) dudit élément de liaison élastique (4) sur un intervalle de temps de référence (ΔT) dans lequel ledit tambour (6) tourne à la vitesse angulaire prédéterminée, et extrapolent ensuite le poids total (m_{tot}) du linge à l'intérieur du tambour (6) à partir de la valeur moyenne (H_m) de la longueur (H) dudit élément de liaison élastique (4).
- 40 10. Machine à laver selon la revendication 8 ou 9, **caractérisé en ce que** ledit dispositif de détection de poids du linge (8) comprend également des deuxièmes moyens de traitement (8, 12), qui calculent un premier coefficient de balourd (m'), indiquant le degré de balourd du linge à l'intérieur dudit tambour (6), en l'extrapolant à partir du modèle temporel ($H(t)$) de la valeur de la longueur (H) de l'élément de liaison élastique (4) lorsque le tambour (6) tourne à ladite vitesse angulaire prédéterminée.
- 45 11. Machine à laver selon la revendication 10, **caractérisée en ce que** lesdits deuxièmes moyens de traitement (8, 12) calculent statistiquement la valeur de la déviation (ΔH) dans le modèle temporel ($H(t)$) de la longueur (H) dudit
- 50
- 55

EP 1 925 708 B1

élément de liaison élastique (4) sur un intervalle de temps de référence (ΔT) dans lequel ledit tambour (6) tourne à la vitesse angulaire prédéterminée, et extrapolent ensuite ledit premier coefficient de balourd (m') à partir de la valeur de ladite déviation (ΔT) dans le modèle temporel ($H(t)$) de la longueur (H) de l'élément de liaison élastique (4).

- 5 **12.** Machine à laver selon l'une quelconque des revendications 8 à 11, **caractérisée en ce que** ledit au moins un élément de liaison élastique (4) est un ressort hélicoïdal (4) fabriqué à partir de matériau électriquement conducteur, et les moyens de mesure (8, 10) déterminent à chaque instant la valeur d'une quantité physique (f) liée à la valeur instantanée de l'inductance (L) dudit ressort hélicoïdal (4).
- 10 **13.** Machine à laver selon la revendication 12, **caractérisée en ce que** lesdits moyens de mesure (8, 10) comprennent un circuit oscillant LC (10), qui comprend ledit ressort hélicoïdal (4) comme inducteur, et génère un signal de fréquence variable (f), dont la valeur instantanée est fonction de la valeur instantanée de l'inductance (L) dudit ressort hélicoïdal (4) ; lesdits premiers moyens de traitement (8, 12) déterminent à chaque instant la valeur de la fréquence (f) du signal généré par ledit circuit oscillant LC (10), afin de déterminer le modèle temporel ($H(t)$) de la longueur (H) dudit ressort hélicoïdal (4).
- 15
- 14.** Machine à laver selon l'une quelconque des revendications 8 à 13, **caractérisée en ce que** ledit dispositif de détection de poids du linge (8) comprend également un capteur de position (13) destiné à déterminer le moment où le tambour (6) se trouve dans une position angulaire de référence, et à fournir un signal ($s(t)$) indiquant le moment où le tambour (6) se trouve dans ladite position angulaire de référence ; ledit dispositif de détection de poids du linge (8) comprenant également des troisièmes moyens de traitement (8, 12) pour déterminer le déphasage temporel (Φ) entre le signal ($s(t)$) généré par ledit capteur de position (13) et le modèle temporel ($H(t)$) de la valeur de la longueur (H) de l'élément de liaison élastique (4) et pour déterminer un second coefficient de balourd, indiquant la position du barycentre du linge irrégulièrement réparti à l'intérieur dudit tambour (6), en l'extrapolant à partir de la valeur dudit déphasage temporel (Φ).
- 20
- 25

30

35

40

45

50

55

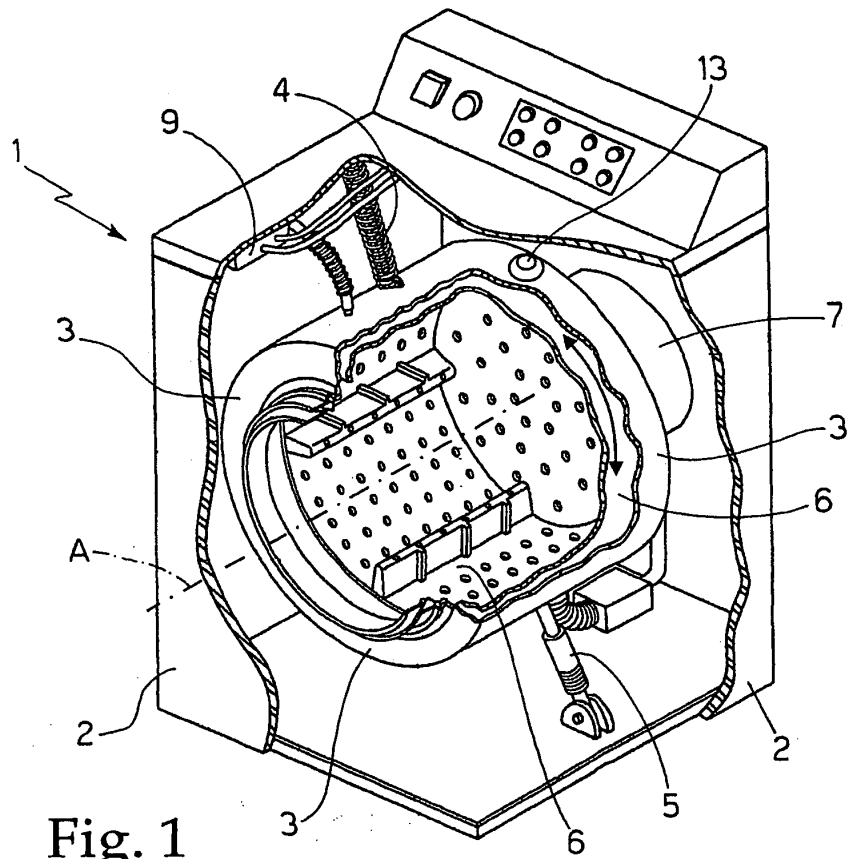

Fig. 1

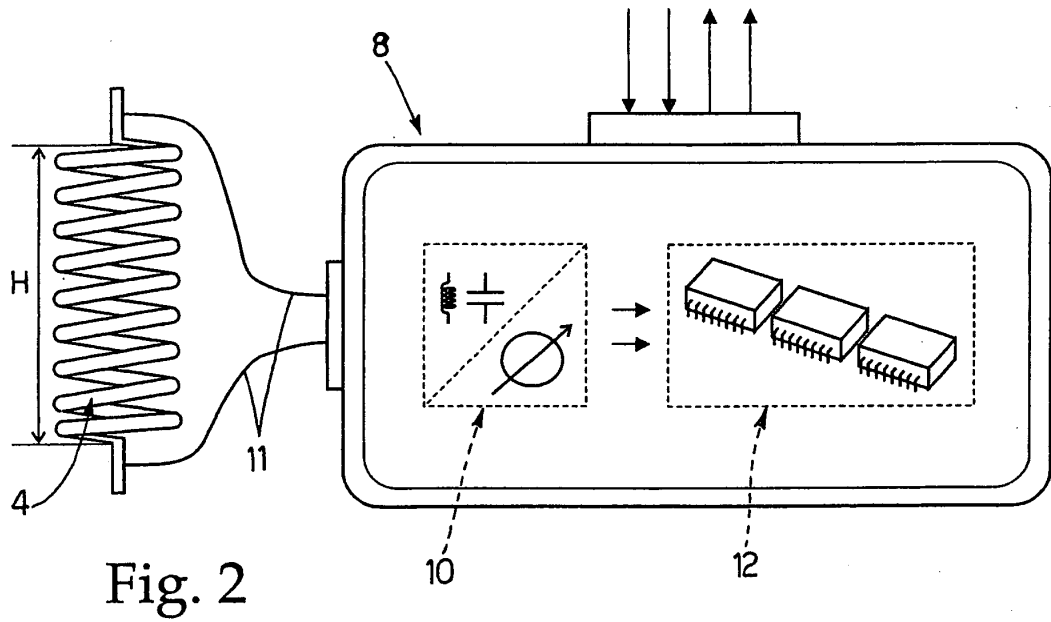
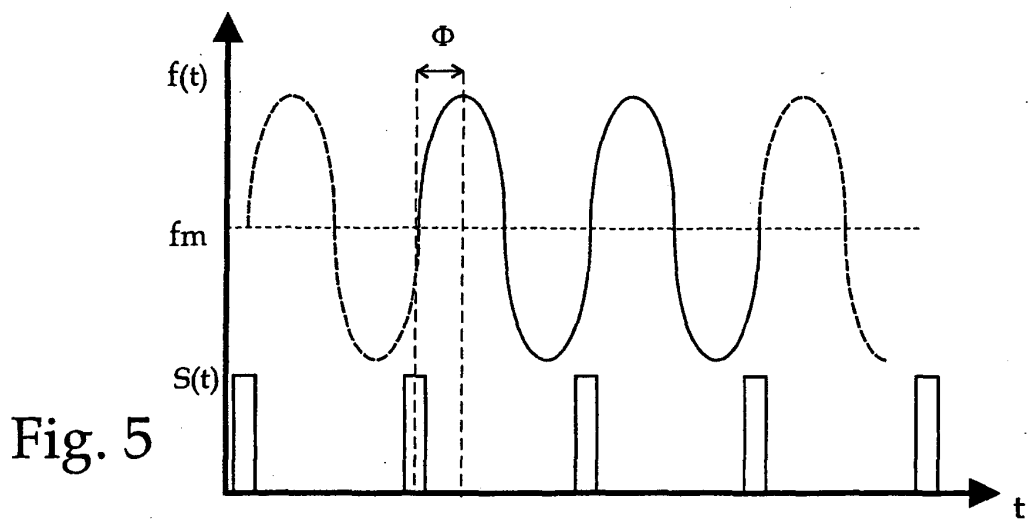
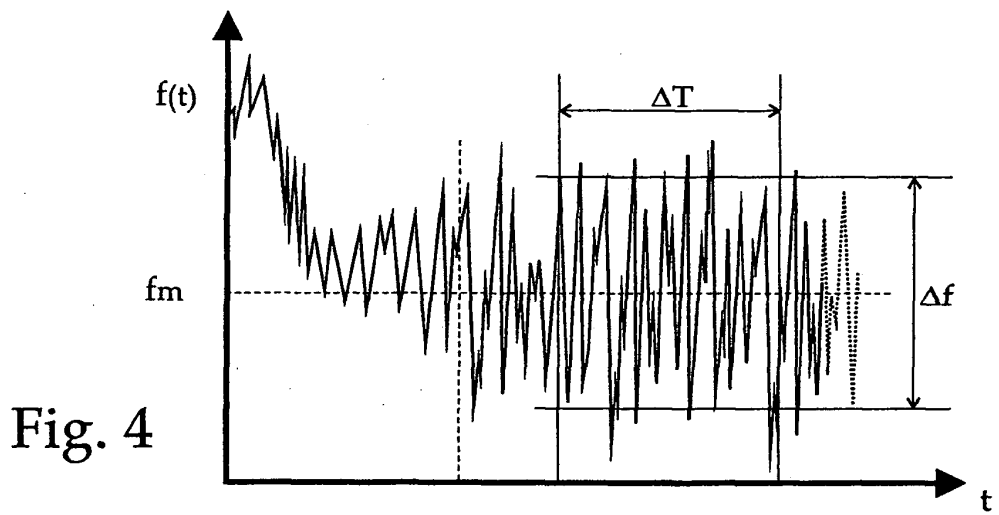
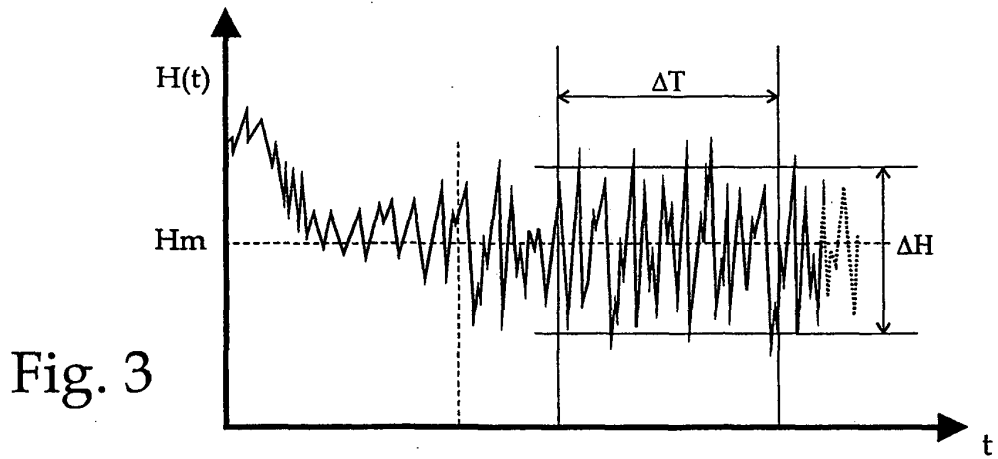

Fig. 2



REFERENCES CITED IN THE DESCRIPTION

This list of references cited by the applicant is for the reader's convenience only. It does not form part of the European patent document. Even though great care has been taken in compiling the references, errors or omissions cannot be excluded and the EPO disclaims all liability in this regard.

Patent documents cited in the description

- GB 2247250 A [0001]