

(19) **DANMARK**

(10) **DK/EP 2198500 T3**



(12) **Oversættelse af
europæisk patentskrift**

Patent- og
Varemærkestyrelsen

-
- (51) Int.Cl.: **H 02 K 1/27 (2006.01)** **H 02 K 15/03 (2006.01)**
- (45) Oversættelsen bekendtgjort den: **2018-09-17**
- (80) Dato for Den Europæiske Patentmyndigheds bekendtgørelse om meddelelse af patentet: **2018-06-20**
- (86) Europæisk ansøgning nr.: **08787720.5**
- (86) Europæisk indleveringsdag: **2008-07-31**
- (87) Den europæiske ansøgnings publiceringsdag: **2010-06-23**
- (86) International ansøgning nr.: **FI2008050447**
- (87) Internationalt publikationsnr.: **WO2009047384**
- (30) Prioritet: **2007-10-09 FI 20070761**
- (84) Designerede stater: **AT BE BG CH CY CZ DE DK EE ES FI FR GB GR HR HU IE IS IT LI LT LU LV MC MT NL NO PL PT RO SE SI SK TR**
- (73) Patenthaver: **Sulzer Management AG, Neuwiesenstrasse 15, 8401 Winterthur, Schweiz**
- (72) Opfinder: **LANTTO, Erkki Juhani, Kytösuontie 8 C 41, FI-00300 Helsinki, Finland**
PALKO, Marko Petteri, Bodomintie 14, FI-02940 Espoo, Finland
TOMMILA, Ville, Töölöntullinkatu 3 A 20, FI-00250 Helsinki, Finland
- (74) Fuldmægtig i Danmark: **Larsen & Birkeholm A/S Skandinavisk Patentbureau, Banegårdspladsen 1, 1570 København V, Danmark**
- (54) Benævnelse: **Rotorstruktur til en elektrisk maskine med permanent magnet**
- (56) Fremdragne publikationer:
JP-A- 9 224 339
US-A- 5 801 470
US-A- 6 047 461
US-A- 6 141 856
US-A1- 2006 158 053
US-A1- 2006 192 455
US-B1- 6 661 145

DESCRIPTION

Technical field

[0001] The invention relates to a rotor structure for a permanent magnet electrical machine, which can operate as an electric motor or electric generator. The invention also relates to a method for the manufacture of a rotor for a permanent magnet electrical machine. The invention further relates to a permanent magnet electrical machine.

Background of the invention

[0002] Materials for permanent magnets, such as neodymium iron borium (NeFeB) or samarium cobalt (SmCo), with which strong magnetic flux density 1... 1.2T can be achieved, are typically very brittle. Especially the ability of the permanent magnet materials to withstand tensile stress is poor. Thus, permanent magnets in the rotor of a permanent magnet electrical machine usually have to be strengthened with support structures made of more viscous material. The said strengthening is very important especially in permanently magnetised high-speed electric machines, in which the peripheral speed of the outer surface of the rotor can be even hundreds of meters in a second.

[0003] Figure 1a illustrates the state-of-the-art rotor structure for a permanent magnet electrical machine, seen from the side. Figure 1b illustrates the cross section A-A of the said rotor structure. The rotor structure has a shaft 101 with permanent magnets 102-113 on its outer surface. The shaft is preferably made of ferromagnetic steel. The outer surface of the shaft 101 is provided with a sleeve 115 made of magnetically non-conductive material, with through-holes for the permanent magnets 102-113. The arrows drawn to the permanent magnets 102-113 describe the magnetising direction of each permanent magnet. A support collar 114 has been arranged onto the sleeve 115 and the permanent magnets 102-113. The support collar 114 is shown in longitudinal section in Figure 1a. The sleeve 115 can be attached to the shaft 101 by, for example, screws 116 and/or a crimped joint based on thermal expansion phenomenon, i.e. thermal crimping. The sleeve 115 can be made, for example, of plastic, aluminium, titanium or some other suitable magnetically non-conductive material. In this document, material, which is not ferromagnetic, is called magnetically non-conductive material. In the rotor structure shown in Figures 1a and 1b, each permanent magnet 102-113 is assembled of several axially consecutive pieces. In this document, axial refers to the direction of the rotor's rotation axis 160. Figure 1c illustrates a longitudinal section of area B shown in Figure 1a. The longitudinal section plane is the x,y plane marked to Figures 1a and 1c. Figure 1c corresponds to an exemplary situation, in which the rotor structure rotates around the rotation axis 160. Permanent magnets are influenced by centrifugal force, which causes the permanent magnets to be pressed against the support collar 114. In other words, the support collar 114 directs radial forces to the permanent magnets, the forces keeping the

permanent magnets on the circular orbit. Forces between the permanent magnets and the support collar stretch the support collar. In Figure 1c, the stretching of the support collar has been strongly exaggerated in order to demonstrate the phenomenon. Figure 1c shows how the permanent magnet 106 is pressed against the support collar 114. A strong surface pressure is applied to the area of the permanent magnet 106 illustrated by the arrow 130. The said strong surface pressure stresses the brittle permanent magnet material 106 and may even cause fractures. An adversely high surface pressure may also be directed to the support collar 114. The situation can be somewhat improved by rounding the edge of the permanent magnet 106 indicated by the arrow 130 and/or by selecting the length of the support collar so that the ends of the support collar and permanent magnets are aligned with each other as closely as possible in the axial direction. The realisation of these matters is complicated by the hard machineability of the permanent magnets and the possible moving of the support collar in relation to the permanent magnets.

[0004] One state-of-the-art solution is to attach the permanent magnets 102-113 to the shaft 101 so that the pressing of the permanent magnets against the support collar 114 would be lighter. The said attachment is generally done by gluing. However, in high-speed electric machines this solution is generally not feasible, because achieving a sufficiently strong attachment between the brittle permanent magnets 102-113 and the shaft 101 is a very challenging task. On the other hand, if the attachment between the permanent magnets and the shaft were able to endure the stress caused by the centrifugal force, i.e. the said attachment could keep the permanent magnets on the circular orbit, internal tensile stresses would be generated to the permanent magnets. This would not be advantageous, because the ability of several permanent magnet materials to tolerate tensile stress is poor.

[0005] US 2006/192455 A1 discloses a rotor structure, wherein a pair of stub shafts are threadably attached to the inner sleeve at each end and a magnet is placed in between.

[0006] US 6,141,856 A discloses the use of supports that are mounted onto the shaft at each end of a retainer, which is installed over the permanent magnets.

Summary of the invention

[0007] The invention relates to the rotor structure of a permanent magnet electrical machine, which can operate as an electric motor or electric generator. The rotor structure of a permanent magnet electrical machine according to the invention has:

- a shaft;
- a permanent magnet;
- a support collar, which encircles the said shaft and the said permanent magnet; and
- a protective piece, which is located between the outer surface of the said shaft and the inner surface of the said support collar and which has been arranged as an axial mechanical extension for the said permanent magnet, and whose mass midpoint is

located at a distance from the geometrical rotation axis of the rotor structure, said protective piece extending in the tangential direction over less than half of the inner circumference of the support collar.

[0008] The invention also relates to a method for the manufacture of a permanent magnet electrical machine, comprising a rotor, which comprises a shaft. In the method of the invention:

- a protective piece is installed so that the said protective piece will form an axial mechanical extension for the permanent magnet in the said rotor and that the mass midpoint of the said protective piece will stay at a distance from the geometrical rotation axis of the rotor, said protective piece extending in the tangential direction over less than half of the inner circumference of the support collar; and
- a support collar is installed to encircle the said rotor shaft, the said permanent magnet and the said protective piece so that the said protective piece will remain between the outer surface of the said shaft and the inner surface of the said support collar.

[0009] The invention further relates to a permanent magnet electrical machine, which can operate as an electric motor or electric generator. The permanent magnet electrical machine of the invention contains a rotor, which has

- a shaft fitted to the frame of the said electric machine with bearings;
- a permanent magnet;
- a support collar, which encircles the said shaft and the said permanent magnet; and
- a protective piece, which is located between the outer surface of the said shaft and the inner surface of the said support collar and which has been arranged as an axial mechanical extension for the said permanent magnet, and whose mass midpoint is located at a distance from the geometrical rotation axis of the rotor structure, said protective piece extending in the tangential direction over less than half of the inner circumference of the support collar.

[0010] The considerable advantage achievable with the invention is that by means of the said protective piece it is possible to reduce the local maximum values of the forces formed between the support collar and the permanent magnet as the rotor rotates without having to shape the permanent magnet or to strive for a structure, in which the ends of the support collar and the permanent magnet are matched as closely as possible in the axial direction.

[0011] Different embodiments of the invention are characterised in what has been disclosed in the dependent patent claims.

Short description of the figures

[0012] Embodiments of the invention and their benefits will be explained next in more detail, referring as examples to the shown embodiments and the enclosed drawings, in which

Figures 1a, 1b and 1c are side views of the rotor structure of a permanent magnet electrical machine according to the state of the art, the cross-section of the said rotor structure, and a detail of the said rotor structure;

Figures 2a and 2b illustrate an embodiment of the rotor structure of a permanent magnet electrical machine seen from the side and a detail of the said rotor structure;

Figures 3a and 3b illustrate an embodiment of the rotor structure of a permanent magnet electrical machine seen from the side and a cross-section of the said rotor structure;

Figure 4 is a side view of an embodiment of the rotor structure of a permanent magnet electrical machine;

Figure 5 illustrates a permanent magnet electrical machine according to an embodiment of the invention;

Figure 6 is a flow chart of the method according to an embodiment of the invention for the manufacture of a permanent magnet electrical machine; and

Figures 7a and 7b illustrate the rotor structure of a permanent magnet electrical machine according to an embodiment of the invention, seen from the side, and a cross-section of the said rotor structure.

Detailed description of the embodiments of the invention

[0013] Figures 1a, 1b and 1c have been explained earlier in this document in connection of the description of the state-of-the-art technology.

[0014] Figure 2a illustrates the rotor structure of a permanent magnet electrical machine according to an embodiment of the invention, seen from the side. Figure 2b is a longitudinal section of a detail of the said rotor structure. The rotor structure has the shaft 201, with permanent magnets 202-206 provided on its outer surface. The shaft is preferably made of ferromagnetic steel. On the outer surface of the shaft 201 there is the sleeve 215 made of magnetically non-conductive material, with through holes for the permanent magnets 202-206. The surface collar 214 is located on the sleeve 215 and the permanent magnets 202-206. In Figure 2a, the support collar 214 is shown in longitudinal section. The sleeve 215 can be attached to the shaft 201, for example, by screws and/or a crimp joint based on thermal expansion phenomenon, i.e. thermal crimping. The sleeve 215 can be made, for example, of

plastic, aluminium, titanium, or some other suitable magnetically non-conductive material. Next to the permanent magnets 202-206 there are protective pieces 220-229. The protective pieces are preferably located so that a protective piece operates as an axial mechanical extension for the permanent magnet. It is also possible to install protective pieces between axially consecutive permanent magnet pieces. In the structure illustrated in Figure 2c, the protective pieces are located as axial mechanical extensions for the permanent magnets 202-206 towards the ends 250 and 251 of the support collar 214. Each permanent magnet 202-206 consists of five axially consecutive pieces.

[0015] Figure 2b is a longitudinal section of the vicinity of the protective piece 220 shown in Figure 2a. The longitudinal section plane is the x,y plane marked to Figures 2a and 2b. Figure 2b corresponds to an exemplary situation, in which the rotor structure rotates around the rotation axis 260. The permanent magnets and protective pieces are influenced by centrifugal force, which causes the permanent magnets and protective pieces to be pressed against the support collar 214. In other words, the support collar 214 applies radial forces to the permanent magnets and protective pieces, the forces keeping the permanent magnets and protective pieces on the circular orbit. Forces between the permanent magnets and protective pieces as well as the support collar stretch the support collar. In Figure 2b, the stretching of the support collar has been strongly exaggerated in order to demonstrate the phenomenon.

[0016] Figure 2b shows how the protective piece 220 and the permanent magnet 202 are pressed against the support collar 214. Strong surface pressure is applied to the edge of the protective piece 220 indicated by the arrow 230, because the sleeve 215 around the shaft 201 does not apply as high a pressure to the inner surface of the support collar as the protective pieces and permanent magnets. The protective piece 220 reduces the surface pressure that the support collar 214 applies to the edge of the permanent magnet 202 indicated by the arrow 231. The density (kg/m^3) of the protective piece material is preferably within the area of 0.3 ... 1.3 times the density of the permanent magnet material. The viscosity of the protective piece material is preferably higher than the viscosity of the permanent magnet material. The protective pieces can be made, for example, of aluminium, titanium, stainless steel, brass, bronze, or copper.

[0017] In the rotor structure according to an embodiment of the invention, the support collar 214 is made of carbon fibre, the fibres of which are substantially in the tangential direction. In this document, tangential direction refers to the direction of the trajectory of the rotary movement.

[0018] In the rotor structure according to an embodiment of the invention the support collar 214 is made of titanium.

[0019] The rotor structure illustrated in Figure 2a has four poles, but it is obvious for one skilled in the art that the structural principle shown in Figure 2a can also be applied to rotor structures, in which the number of poles is two or more than four.

[0020] Figure 3a illustrates the rotor structure of a permanent magnet electrical machine according to an embodiment of the invention, seen from the side. Figure 3b illustrates the cross-section A-A of the rotor structure in question. The rotor structure has the shaft 301, with permanent magnets 302 and 303 provided on its outer surface. The shaft is preferably made of ferromagnetic steel. The arrows drawn to the permanent magnets 302 and 303 indicate the magnetisation direction of each permanent magnet. The permanent magnets 302 and 303 are located in recesses on the outer surface of the said shaft 301. There is a support collar 314 around the shaft 301 and the permanent magnets 302 and 303. In Figure 3a, the support collar 314 has been shown in longitudinal section. The rotor structure has protective pieces, which are located between the outer surface of the said shaft and the inner surface of the said support collar and which are arranged as axial mechanical extensions for the permanent magnets. The protective pieces 320 and 321 are axial mechanical extensions for the permanent magnet 302.

[0021] In the rotor structure according to an embodiment of the invention, pieces 305, 306, 307 and 308 of magnetically non-conductive material are provided next to the surfaces of the permanent magnets 302 and 303 pointing to the tangential direction. The pieces 305, 306, 307 and 308 of magnetically non-conductive material can be, for example, plastic, aluminium, titanium, or some other suitable non-ferromagnetic material.

[0022] In the rotor structure according to an embodiment of the invention, each permanent magnet 302 and 303 has a radial play 330 and 331 between the support collar 314 and the shaft 301. In the situation depicted in Figure 3b, the permanent magnets 302 and 303 can move on the plane of the picture surface 3b away from the rotation axis 360. In the situation depicted in Figure 3b, the spaces 330 and 331 between the permanent magnets and the support collar 214 make possible the play of the permanent magnets 302 and 303. Depending on the position of the permanent magnets 302 and 303 in the said radial play, the spaces making possible the play can be either totally or partly also between the outer surface of the shaft 301 and the permanent magnets 302 and 303. As can be seen from Figure 3b, the mutual fit of the permanent magnets 302 and 303 and the support collar 314 is not mechanically tight, so that the support collar can be pushed to place by using a movement in the direction of the rotation axis 332 without putting the support collar into contact with the permanent magnets of possibly brittle material during installation.

[0023] In the rotor structure according to an embodiment of the invention, the spaces 330 and 331 that enable the radial play of the permanent magnets 302 and 303 contain air. In the rotor structure according to another embodiment of the invention, the spaces 330 and 331 that enable the radial play of the permanent magnets 302 and 303 contain elastic material, which can be, for example, silicon.

[0024] The rotor structure illustrated in Figures 3a and 3b is bipolar, but it is obvious for one skilled in the art that the structural principle shown in Figures 3a and 3b can also be applied to rotor structures, in which the number of poles is more than two.

[0025] Figure 4 illustrates the rotor structure of a permanent magnet electrical machine according to an embodiment of the invention, seen from the side. The rotor structure has two axially successive sections 471 and 472, each containing:

- permanent magnets (such as permanent magnet 402),
- a support collar encircling the shaft 401 and the said permanent magnets, and
- protective pieces (such as the protective piece 420) located between the outer surface of the said shaft and the inner surface of the said support collar, and arranged as axial mechanical extensions for the permanent magnets.

[0026] The structure illustrated in Figure 4 is advantageous especially when the sleeves 415 and 415a and/or support collars 414 and 414a have different thermal expansion factor from the shaft 401. With the structure illustrated in Figure 4 it is possible to reduce the axial mechanical stresses caused by temperature variations. In Figure 4, the support collars 414 and 414a have been shown in longitudinal section, and the permanent magnets and protective pieces have been shown as black surfaces.

[0027] In the rotor structure of a permanent magnet electrical machine according to an embodiment of the invention there are more than two axially successive sections, each containing permanent magnets, a support collar, and protective pieces.

[0028] Figure 5 illustrates a permanent magnet electrical machine according to an embodiment of the invention. The electric machine has the frame 581, to which the stator core 582 is attached. The grooves in the stator core have the stator winding 583. The rotor of the electric machine 584 has:

- a shaft 501, which is fitted to the frame 581 of the electric machine with bearings;
- permanent magnets (such as permanent magnets 502 and 503),
- a support collar 514, which encircles the said shaft and the said permanent magnets, and
- protective pieces (such as protective pieces 520 and 521), located between the outer surface of the said shaft and the inner surface of the said support collar, and arranged as axial mechanical extensions for the permanent magnets.

[0029] The support collar 514, frame 581, stator core 582, stator winding 583, and bearings 585 and 586 have been shown in longitudinal section in Figure 5.

[0030] In the electric machine according to an embodiment of the invention, at least one of the bearings 585 and 586 is an active magnetic bearing.

[0031] In the electric machine according to an embodiment of the invention, both bearings

585 and 586 are active magnetic bearings.

[0032] In the electric machine according to an embodiment of the invention, at least one of the bearings 585 and 586 is a gas bearing.

[0033] In the electric machine according to an embodiment of the invention, at least one of the bearings 585 and 586 is a rolling bearing, which can, for example, be a ball or roller bearing.

[0034] In the electric machine according to an embodiment of the invention, at least one of the bearings 585 and 586 is a sliding bearing, which can be, for example, a rocker segment bearing.

[0035] Figure 6 is a flow chart of the method according to an embodiment of the invention for the manufacture of a rotor for a permanent magnet electrical machine. In step 601 a protective piece is installed so that the said protective piece will form an axial mechanical extension for the permanent magnet in the said rotor. In step 602 a support collar is installed to encircle the said rotor shaft, the said permanent magnet and the said protective piece so that the said protective piece stays between the outer surface of the said shaft and the inner surface of the said support collar. The support collar can be installed, for example, by pushing it with an axial movement to encircle the said shaft, the permanent magnet and the protective piece.

[0036] Figure 7a illustrates the rotor structure of a permanent magnet electrical machine according to an embodiment of the invention, seen from the side. Figure 7b is a cross-section A-A of the rotor structure in question. The rotor structure has the shaft 701, which is encircled by a tubular permanent magnet 702. The shaft is preferably made of ferromagnetic steel. The shaft 701 and the permanent magnet 702 is encircled by the support collar 714. The rotor structure has the protective pieces 720-725, which are located between the outer surface of the said shaft and the inner surface of the said support collar, and which are arranged as axial mechanical extensions for the permanent magnet. There are four protective pieces 720-723 shown in Figure 7b. It is also possible to use one ring-shaped protective piece instead of the protective pieces 720-723. However, it is preferable that the ring-shaped protective piece is made of more elastic material than the permanent magnet 702. In Figure 7a, the permanent magnet 702, support collar 714 and protective pieces 720, 722, 724 and 725 are shown in longitudinal section. The rotor structure has the support flanges 771 and 772, which are arranged to support the permanent magnet 702, support collar 714 and protective pieces 720-725 in the axial direction. The said support flanges 771 and 772 can be attached to the shaft 701, for example, by screws and/or by a crimping joint based on thermal expansion phenomenon, i.e. thermal crimping.

REFERENCES CITED IN THE DESCRIPTION

This list of references cited by the applicant is for the reader's convenience only. It does not

form part of the European patent document. Even though great care has been taken in compiling the references, errors or omissions cannot be excluded and the EPO disclaims all liability in this regard.

Patent documents cited in the description

- US2006192455A1 [0005]
- US6141856A [0006]

P A T E N T K R A V

1. Rotorstruktur til en elektrisk maskine med permanent magnet, som har

- 5
- en aksel (201, 301, 401, 701),
 - en permanent magnet (202-206, 302, 303, 402, 702),
 - en støttekrave (214, 314, 412, 414a, 714), der omslutter akslen og den permanente magnet, og
 - en beskyttelsesdel (220-229, 320, 321, 420, 720-725) placeret mellem
- 10 akslens yderflade og støttekravens inderflade og anordnet som en aksial mekanisk forlængelse til den permanente magnet,

kendetegnet ved, at beskyttelsesdelens massemidtpunkt er placeret i en afstand fra rotorstrukturens geometriske drejningsakse (260, 460), idet beskyttelsesdelen strækker sig i den tangentielle retning over mindre end halvdel af støttekravens indvendige omkreds.

15

2. Rotorstruktur ifølge krav 1, **kendetegnet ved, at** den permanente magnet (302, 303) er placeret i en reces på akslens (301) yderflade.

20

3. Rotorstruktur ifølge krav 2, **kendetegnet ved, at** en del (305, 306, 307, 308) fremstillet af magnetisk ikke-ledende materiale er placeret ved siden af overfladen, der peger i den permanente magnets (302, 303) tangentielle retning.

25

4. Rotorstruktur ifølge krav 1, **kendetegnet ved, at** der på akslens yderflade er en muffe (215, 415, 415a) fremstillet af magnetisk ikke-ledende materiale og forsynet med et gennemgående hul til den permanente magnet og anordnet til at støtte støttekraven (214, 414, 414a) i forhold til akslen.

30

5. Rotorstruktur ifølge krav 1 eller 2 eller 3 eller 4, **kendetegnet ved, at** den permanente magnet (302, 303) har et radiale spillerum (330, 331) mellem støttekraven (314) og akslen (301).
- 5 6. Rotorstruktur ifølge krav 5, **kendetegnet ved, at** rummet (330, 331), der muliggør spillerummet, indeholder elastisk materiale.
7. Rotorstruktur ifølge krav 1, **kendetegnet ved, at** rotorstrukturen har mindst to aksiale successive sektioner (471, 472), der hver indeholder:
- 10
- en permanent magnet,
 - en støttekrave, der omslutter akslen og den permanente magnet, og
 - en beskyttelsesdel placeret mellem akslens yderflade og støttekravens inderflade og anordnet som en aksial mekanisk forlængelse til den
- 15 permanent magnet.
8. Rotorstruktur ifølge krav 1, **kendetegnet ved, at** støttekraven er fremstillet af kulfiber, hvor fibrene i det væsentlige er orienterede i den tangentielle retning.
- 20
9. Rotorstruktur ifølge krav 1, **kendetegnet ved, at** støttekraven er fremstillet af titanium.
10. Elektrisk maskine med permanent magnet, hvor rotoren (584) har:
- 25
- en aksel (501) fastgjort til rammen (581) på den elektriske maskine med lejer,
 - en permanent magnet (502, 503),
 - en støttekrave (514), der omslutter akslen og den permanente magnet, og
- 30
- en beskyttelsesdel (520, 521) placeret mellem akslens yderflade og støttekravens inderflade og anordnet som en aksial mekanisk forlængelse til den permanente magnet,

kendetegnet ved, at beskyttelsesdelens massemidt punkt er placeret i en afstand fra rotorens geometriske drejningsakse, idet beskyttelsesdelen strækker sig i den tangentielle retning over mindre end halvdelen af støttekravens indvendige omkreds.

5

11. Fremgangsmåde til fremstilling af en elektrisk maskine med permanent magnet, omfattende en rotor, der omfatter en aksel, **kendetegnet ved, at** ved fremgangsmåden:

- 10
- installeres (601) en beskyttelsesdel, således at beskyttelsesdelen danner en aksial mekanisk forlængelse til den permanente magnet i rotoren, og at beskyttelsesdelens massemidt punkt forbliver i en afstand fra rotorens geometriske drejningsakse, idet beskyttelsesdelen strækker sig i den tangentielle retning over mindre end halvdelen af støttekravens indvendige omkreds, og
- 15
- installeres (602) en støttekrave til at omslutte rotorakslen, den permanente magnet og beskyttelsesdelen, således at beskyttelsesdelen forbliver mellem akslens yderflade og støttekravens inderflade.

DRAWINGS

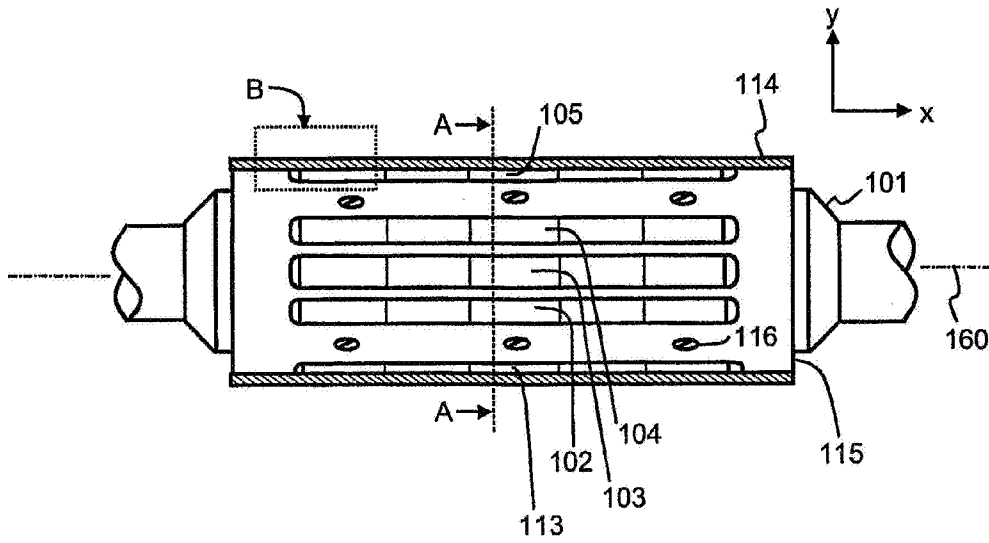

Figure 1a

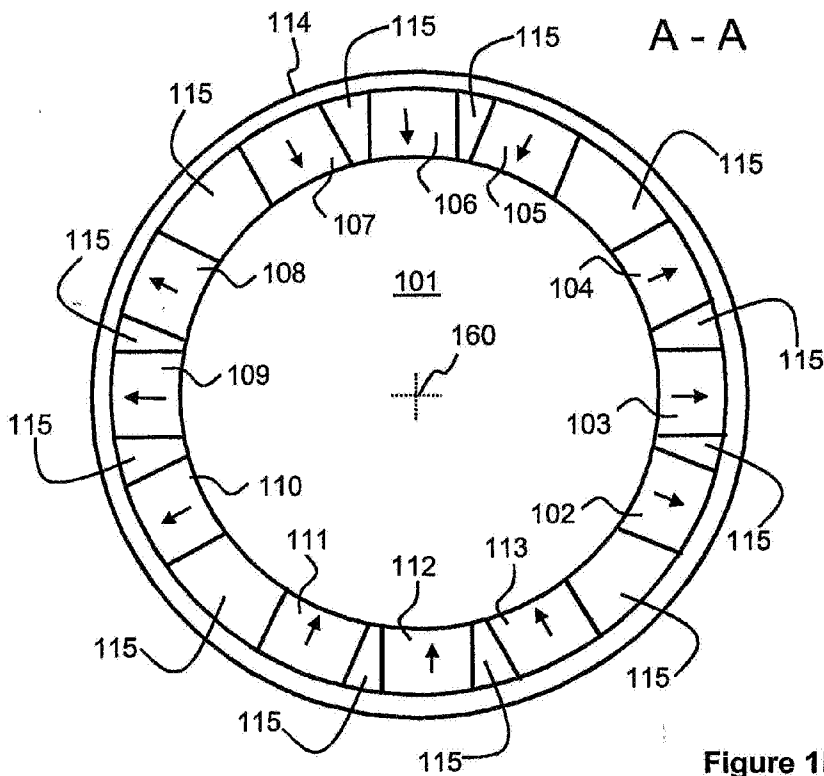

Figure 1b

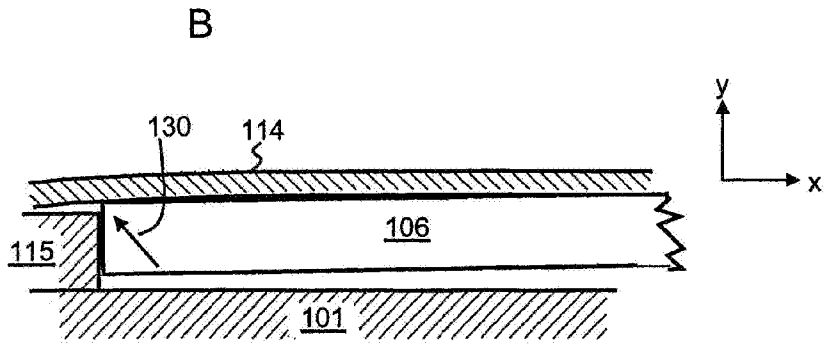

Figure 1c

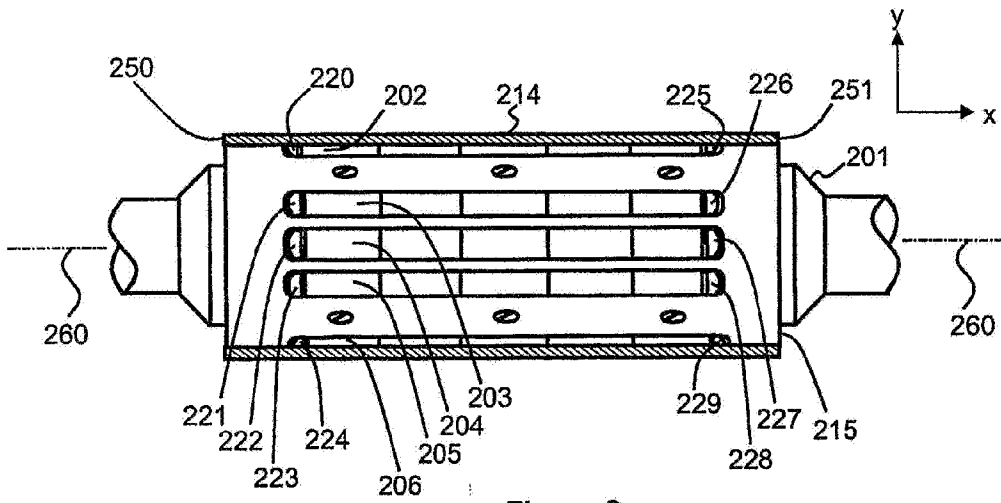

Figure 2a

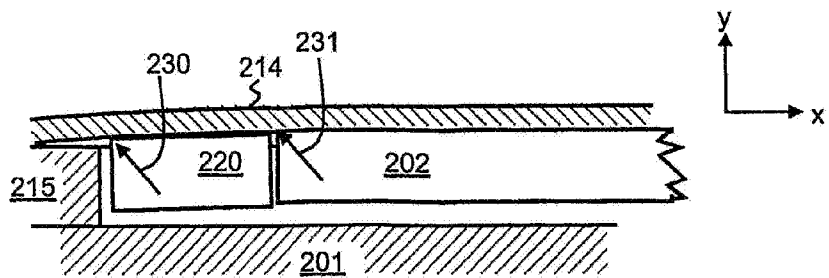

Figure 2b

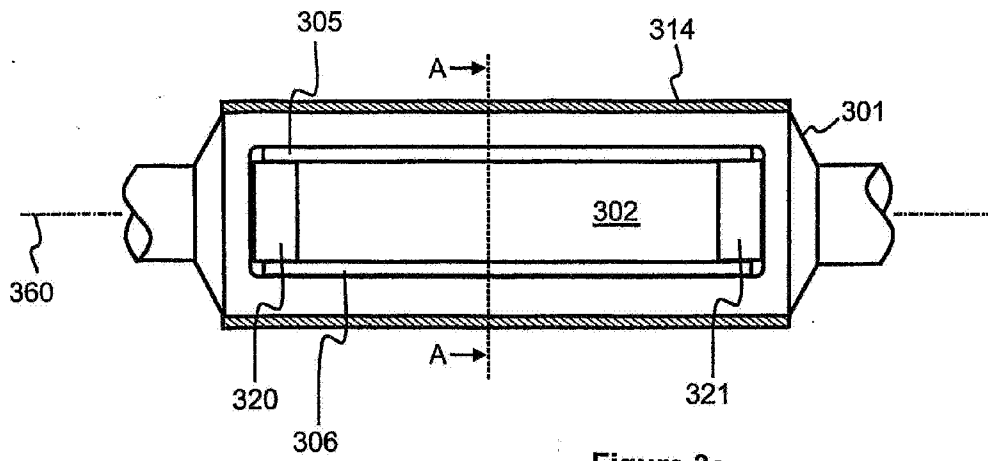

Figure 3a

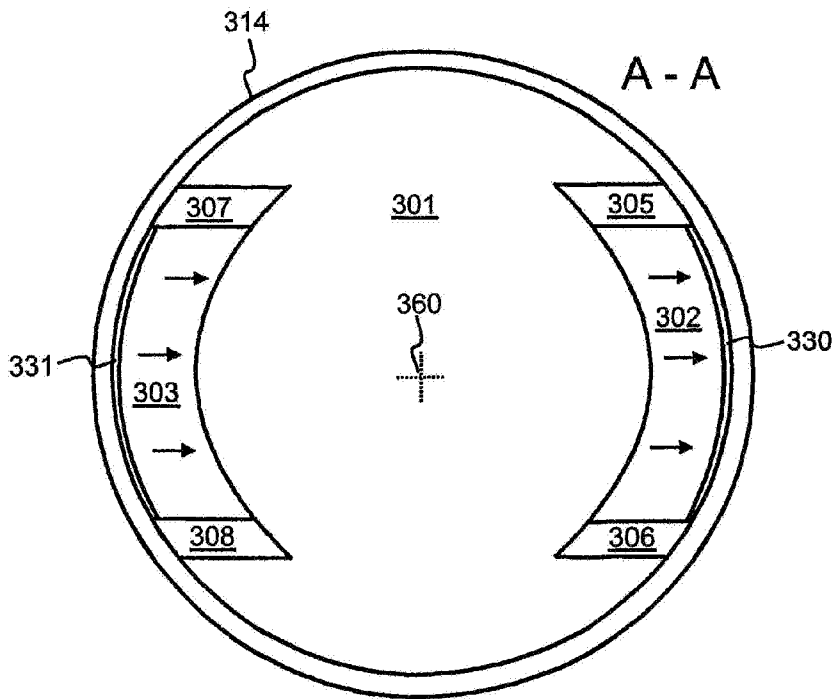

Figure 3b

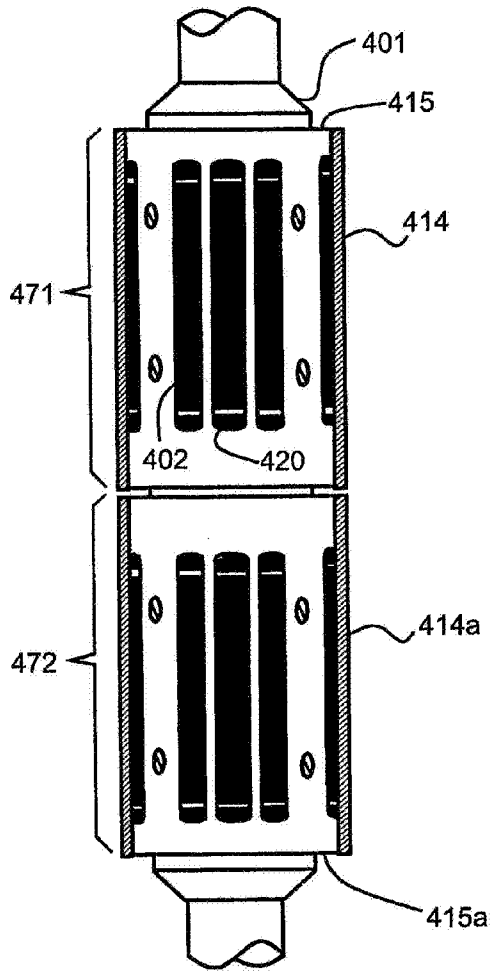

Figure 4

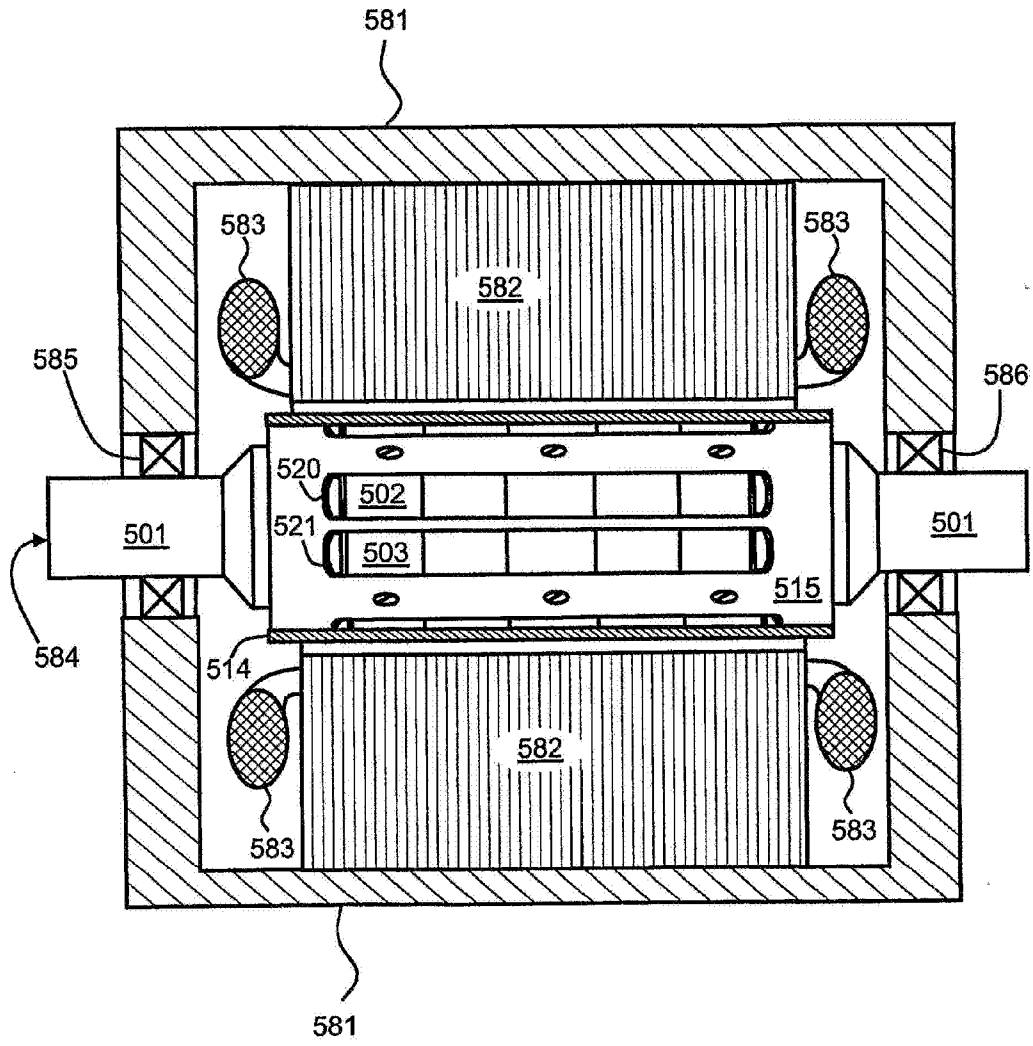

Figure 5

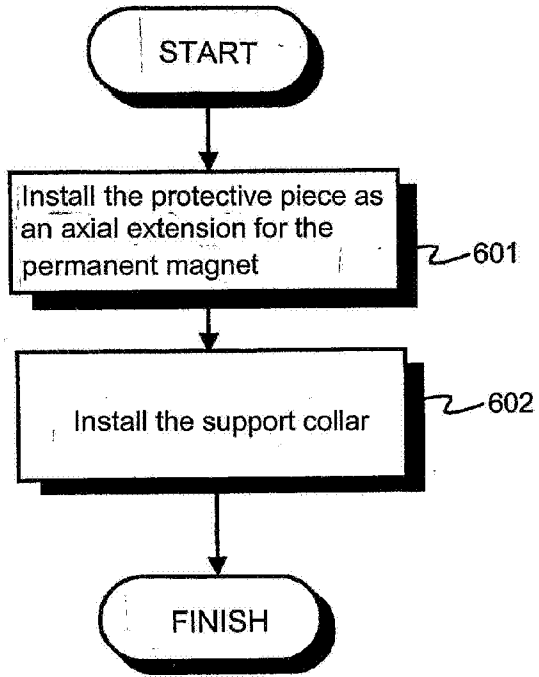

Figure 6

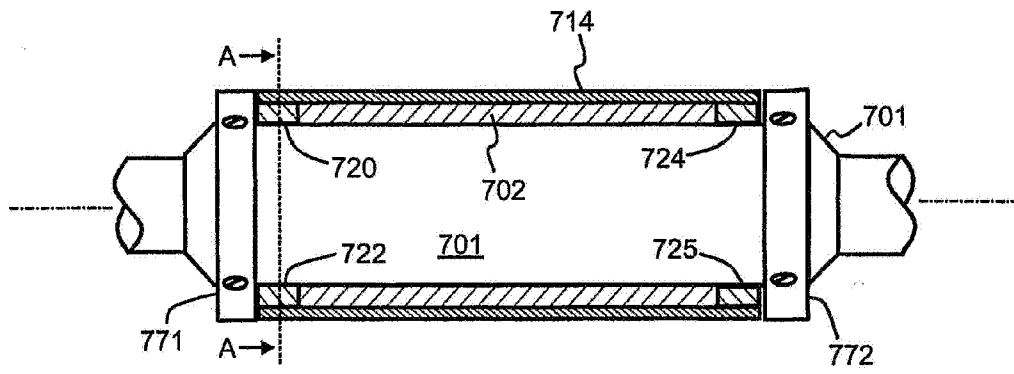

Figure 7a

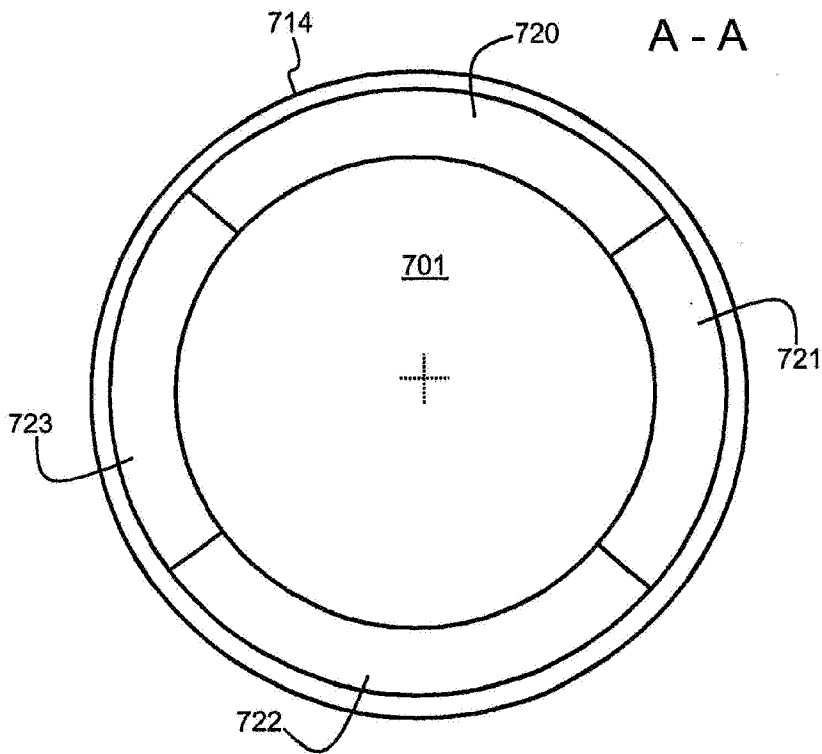

Figure 7b